

OPERATOR'S MANUAL

RTW 300W SERIES

POWER SUPPLY

SINGLE OUTPUT, UNIVERSAL INPUT
SINGLE PHASE, 0.99 POWER FACTOR

KEPCO INC.
An ISO 9001 Company.



MODEL

RTW 300W SERIES

POWER SUPPLY MODELS

RTW 3.3-70KC, RTW 5-60KC, RTW 12-25KC,
RTW 15-20KC, RTW 24-13KC, RTW 28-11KC,
RTW 48-6.5KC

IMPORTANT NOTES:

- 1) The contents of this manual are protected by copyright. Reproduction of any part can be made only with the specific written permission of Kepco, Inc.
- 2) Data subject to change without notice.

©2011, KEPCO, INC
P/N 228-1544R3



KEPCO, INC. • 131-38 SANFORD AVENUE • FLUSHING, NY. 11355 U.S.A. • TEL (718) 461-7000 • FAX (718) 767-1102
email: hq@kepcopower.com • World Wide Web: <http://www.kepcopower.com>

TABLE OF CONTENTS

SECTION	PAGE
1. Introduction.....	1
1.1 Scope of Manual.....	1
1.2 Description.....	1
2. Specifications.....	1
3. Installation.....	1
4. Operation.....	5
4.1 Voltage Adjustment.....	7
4.2 Remote Voltage Control.....	7
4.3 Remote Turn On-Turn Off.....	7
5. Alarm Functions.....	8
5.1 Overvoltage Protection.....	8
5.2 Current Limit.....	8
5.3 Optical Coupler Output Alarm Circuit.....	8
5.4 Undervoltage.....	8
6. Load Connection.....	8
6.1 Connecting the Load Using Local Sensing.....	8
6.2 Connecting the Load Using Remote Sensing.....	8
6.3 Parallel Connection.....	9
6.3.1 Current Balancing.....	10
6.3.2 Master-Slave Configurations.....	10
6.3.2.1 Master-Slave, Multiple Loads.....	10
6.3.2.2 Master-Slave, Single Load.....	11
6.4 Series Connection.....	11
6.5 Preliminary Electrical Check.....	12
6.6 Accessories.....	12

LIST OF FIGURES

FIGURE	TITLE	PAGE
1	Mechanical Outline Drawing of the RTW 300W Power Supply (Cover Removed).....	4
2	Power Rating vs. Temperature.....	5
3	Mounting Positions for the RTW 300W Power Supply.....	5
4	Locations of Operating Controls, Indicators and Terminals.....	6
5	Connections for Remote Voltage Control.....	7
6	Output Alarm Circuit, Optically Isolated.....	8
7	Correct and Incorrect Methods of Load Connection.....	9
8	Parallel Connection with Current Balancing.....	10
9	Parallel Connection, Master-Slave, Multiple Loads.....	10
10	Parallel Connection, Master-Slave, Single Load.....	11
11	Series Connection.....	11
12	Functional Checkout.....	12

LIST OF TABLES

TABLE	TITLE	PAGE
1	Output Ratings and Specifications.....	1
2	Power Supply Ratings and Specifications.....	2
3	Function of Controls, Indicators and Terminals.....	6
4	Mating Connectors.....	7

1. INTRODUCTION

1.1 SCOPE OF MANUAL

This Operator's Manual covers the installation and operation of the Kepco RTW 300W Series of Switching Power Supplies. For service information, write directly to: Kepco Inc., 131-38 Sanford Avenue, Flushing, New York, 11355, U.S.A. Please state Model Designation and Serial Number of your RTW Power Supply. This information can be found on the nameplate of the unit.

1.2 DESCRIPTION

The Kepco RTW 300W Series consists of seven models of switching power supplies, each with a single output as shown in Table 1. Units may be operated with a nominal 100V a-c to 240V a-c (input voltage range 85 to 265 Va-c), 50-60 Hz (input frequency range 47-66Hz; units also operate up to 440Hz although leakage current, power factor and efficiency specifications may not be met). They will also operate on 110V to 370V d-c input. The RTW 300W Series employs a forward converter operating at 140 KHz. Regulation is provided by pulse width modulation. A power stage with a MOSFET on each side of the primary winding, operating in the forward mode provides a smooth isolated d-c output. A thyristor circuit prevents excessive turn-on current surge. A boost converter operating at about 90KHz provides Power Factor Correction (PFC). Overvoltage protection, an isolated remote TTL ON-OFF control, an LED "output voltage ON" light and an output voltage adjust trimmer are provided. RTW 300W are low-profile convection-cooled units, manufactured on an aluminum frame. Models with suffix KC include a cover; for applications where a cover is not needed, contact Kepco for further information.

2. SPECIFICATIONS

Table 1 contains specifications and operating limits of individual RTW 300W Series models. Table 2 contains specifications and operating limits common to all RTW 300W Series Models. These specifications are at nominal input voltages at 25°C unless otherwise specified.

3. INSTALLATION

Refer to Figures 1 and 3.

TABLE 1. OUTPUT RATINGS AND SPECIFICATIONS

MODEL RTW 300W		3.3-70KC	5-60KC	12-25KC	15-20KC	24-13KC	28-11KC	48-6.5KC
Output Volts d-c		3.3V	5V	12V	15V	24V	28V	48V
Adjustment Range (Volts)		1.8 - 3.6	3.5 - 5.6	7.2 - 14.4	10.5 - 18.0	16.8 - 26.4	19.6 - 33.6	33.6 - 55.0
Voltage Setting (Volts)		3.3 ±0.03	5 ±0.05	12 ±0.12	15 ±0.15	24 ±0.24	28 ±0.28	48 ±0.48
Maximum Output Rating (Watts)		231	300	300	300	312	308	312
Output Current (max.) (Amps) ⁽⁵⁾		70	60	25	20	13	11	6.5
Current Limit Setting (Amps) ⁽¹⁾		73.5 - 84	63 - 72	26.3 - 30	21 - 24	13.7 - 15.6	11.5 - 13.2	6.8 - 7.8
Current Short Circuit (Amps)		87	78	36	29	25	17.5	11.5
OVP Setting (Volts) ⁽²⁾		4.0 - 4.6	6.2 - 7.0	14.8 - 16.8	18.6 - 21.0	29.8 - 33.6	34.7 - 39.2	55.5 - 59.9
Undervoltage Protection ⁽⁴⁾	% Output	60	60	20	20	20	20	20
	Time (Sec)	3	3	15	15	15	15	15
Efficiency % typical	AC Input 100V	83	84	83	85	85	85	86
	AC Input 200V	86	87	86	88	88	88	89
Ripple & Noise ⁽³⁾ (mV, p-p)	Ripple	80	80	100	100	150	150	200
	Ripple noise	120	120	150	150	200	200	300
Acceptable Output Capacitor (µF) ⁽⁶⁾		10,000	10,000	10,000	10,000	10,000	10,000	10,000

(1) Square type.

(2) When overvoltage is detected, output is shut OFF. Recovery is by removing and reapplying power after about 30 seconds or by opening and reclosing the ±RC pins of connector CN 2 or CN3

(3) Ripple and noise specifications are 1.5 times indicated values for temperature range of -10 to 0°C. Ripple and noise levels above are satisfied when conditions are 0 to 100% load, 0 to 50°C (for 50 to 71°C see Figure 2), and bandwidth ≤ 100MHz.

(4) When output falls below rated output by the percent listed, for the time listed, output is shut OFF. Recovery is by removing and reapplying power or by opening and reclosing the ±RC pins of connector CN 2 or CN3.

(5) Minimum output current is 0 Amps.

(6) Start-up time will change if this capacitor is added.

TABLE 2. POWER SUPPLY RATINGS AND SPECIFICATIONS

SPECIFICATION		DESCRIPTION		
Input Voltage	Nominal: Range:	100 to 120V a-c, 200 to 240V a-c 85-265V a-c	0 to 100% load, -10 to 71°C. Output power derated to 90% of max. for input voltage between 85 and 90V a-c when mounting positions B or C are used (see Figure 3). CAUTION: Operation with input voltage outside specified range may damage unit.	
		110-370V d-c	Polarity insensitive. (0 to 100% load, -10 to 71°C, derated per Figure 2.) Safety ratings apply for a-c input operation only.	
Input Source Frequency	Nominal: Range:	50-to 60 Hz 47-440 Hz.	Units operate up to 440 Hz, however the leakage current exceeds the UL leakage safety specification limit, and power factor and efficiency specifications may not be met.	
Input Current: (Maximum Load At 25°C with Nominal Output Voltage)		4A rms max. (3.6A rms max for the 3.3V model, 6A rms typ. for 24V model)	100 - 120V a-c	
		2A rms max. (1.8A rms max for the 3.3V model, 3A rms typ. for 24V model)	200 - 240V a-c	
Input Protection		A limiting resistor in series with a resistor fuse (in parallel with a thyristor circuit) reduces start-up surge. Units are protected against shorts by an input fuse. Fuse value 10.0A at 250 Volts (Littelfuse P/N 0215010.MXF4P, Kepco P/N 541-0144).		
Input Surge cold start, interval > 30 Sec ⁽¹⁾		15A typ., 20A max. first surge	100 - 120V ac	
		30A typ., 40 max. first surge	200- 240 V ac	
Leakage Current:		0.3mA typ., 0.5mA max.	100V a-c, 60Hz (per Den-An)	
		0.4mA typ., 0.7mA max.	240V a-c, 60Hz (per IEC 950 and UL1950)	
Power Factor		0.99 typical	100V a-c	
		0.93 typical	240V a-c	
Stabilization			Typical	Maximum
		Source Effect (min - max) (85 to 132 V a-c, 170 to 265V a-c)	0.1%	0.2%
		Load Effect, measured at sensing terminals (0%-100% load change)	0.2%	0.4%
		Temperature Effect (-10° to 71°C)	0.5%	1.0%
		Combined Effect (Source, Load and Temperature)	±0.9%	±1.8%
		Drift (from 1/2 to 8 hours at 25°C)	0.2%	0.5%
Remote Error Sensing:		Compensation up to 0.4 Volts per load wire (0.15 Volts for 3.3V model, 0.25 Volts for 5V model) (see Figure 7). Transient recovery specs may not be satisfied if remote sensing used.		
Transient Recovery characteristic	excursion	±4% maximum	50% to 100% rated output current; transient time >50µSec	
	recovery time	1 mS maximum		
Start-up Time		220 mSec typical, 350 mSec maximum	100V a-c	
		120 mSec typical, 200 mSec maximum.	240V a-c	

(1) First surge only, not including current flow into EMI filter

TABLE 2. POWER SUPPLY RATINGS AND SPECIFICATIONS (CONTINUED)

SPECIFICATION	DESCRIPTION	
Output Hold-up Time	30 mSec typ. (25 mSec typ. for 5V and 15V models), 20 mSec min.	100V a-c
	40 mSec typ. (30 mSec typ. for 5V and 15V models), 25 mSec min.	240V a-c
Overvoltage Protection	When the Power Supply goes into an overvoltage condition, the output is cut OFF. To restart (reset) the unit, it is necessary to remove, then reconnect the a-c input power after about 30 seconds, or to open and then reclose the RC terminals.	
Remote Control ON/OFF:	"High", 2.4V to 24V (or open), unit OFF- Fan Off ; "Low", 0.0V to 0.4V (or closed), unit ON. When remote ON/OFF is not in use, ±RC pins of connector CN2 or CN3 should be shorted (use connector supplied) for unit to operate.	
Operating Temperature:	-10 to 71°C (see figures 2 and 3)	
Startup Temperature	-20 to -10°C (see Figure 2)	
Storage Temperature:	-30°C to +75°C	
Humidity:	10% to 95% relative humidity, noncondensing, Wet Bulb temperature </=35°C	operating and non-operating
Vibration:	5-10 Hz., 10mm amplitude, 10-200 Hz., acceleration 64.3ft./s ² (19.6m/s ²) (2g)	non-operating, 1 hr. on each of 3 axes, sweep time 10 minutes
Shock:	Acceleration: 1929.1ft./s ² (588m/s ²) (60g), Pulse Duration: 11ms ± 5 mSec	(non-operating, 1/2 sine pulse, three shocks on each axis)
Withstanding voltage : (at 15-35°C ambient, 10-85% relative humidity)	2000Va-c for 1 minute. Cutout current is 10mA	Between input and ground
	500Va-c for 1 minute. Cutout current is 40mA	Between output and ground
	3000Va-c for 1 minute. Cutout current is 10mA	Between input and output
Insulation Resistance: (at 15-35°C ambient, 10-85% relative humidity)	Between output and ground, input and ground, and input and output, 100 Megohms minimum (500Vdc)	
Safety:	UL60950-1 First Ed., CSA Electrical Bulletin 22.2 No.60950-1 , and TÜV Rheinland EN60950-1:2001, Assistance for Den-AN ⁽²⁾ (ambient temp.50°C max.). RTW 300W units are CE marked per the Low Voltage Directive (LVD), 73/23/EEC and 93/68/EEC. The standards do not apply with DC input operation	
EMI Conducted:	Designed to meet FCC Class B, VCCI-Class B, EN55011-B, EN55022-B	
EMI Radiated:	Designed to meet FCC Class B, VCCI-Class B, EN55011-B, EN55022-B	
ESD immunity:	Designed to meet EN61000-4-2, level 4	normal operation
Electrical fast transient burst:	EN61000-4-4 level 3	normal operation
Surge withstand:	EN61000-4-5, level 4	no damage
Power Frequency Magnetic Field:	EN61000-4-8, level 4	normal operation
Radiated susceptibility:	EN61000-4-3 level 3	normal operation
Conducted susceptibility:	EN61000-4-6 level 3	normal operation
Voltage dips interruptions and variations	EN61000-4-11	normal operation
Input harmonics current:	Designed to meet EN61000-3-2	
Dimensions:	4.72 in. (120 mm) H x 1.57 in. (40 mm) W x 9.84 in. (250 mm) L	
Mounting:	Four No. M4 tapped holes on the sides and the bottom	
Maximum Screw Penetration:	0.24 in. (6 mm)	
Cooling:	Convection	
Frame Material	Aluminum	
Weight	2.87 lbs. (1.3Kg) maximum	

(2) Meets the creepage and clearance requirement of Den-An Appendix 8 (100V a-c only).

NOTE: OUTPUT DERATING SHOWN FOR INPUT VOLTAGE FROM 90 TO 265 VAC.

FOR MOUNTING POSITIONS B OR C, DERATE VALUES SHOWN BY ADDITIONAL 10% FOR INPUT VOLTAGE FROM 85 TO 90 VAC.

THE POWER SUPPLY WILL STARTUP BETWEEN -20 AND -10°C BUT MAY NOT MEET PUBLISHED SPECIFICATIONS.

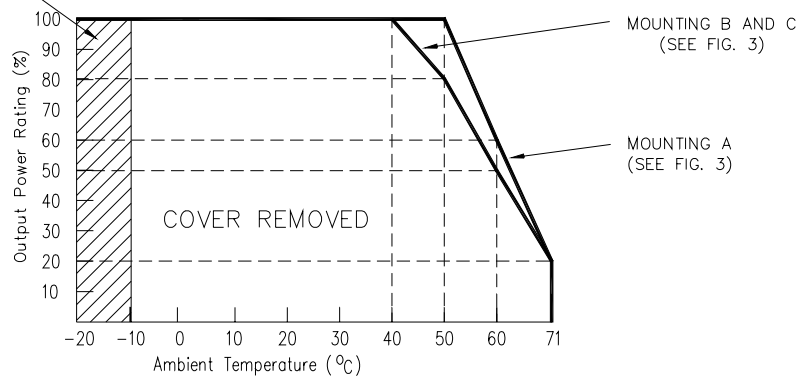
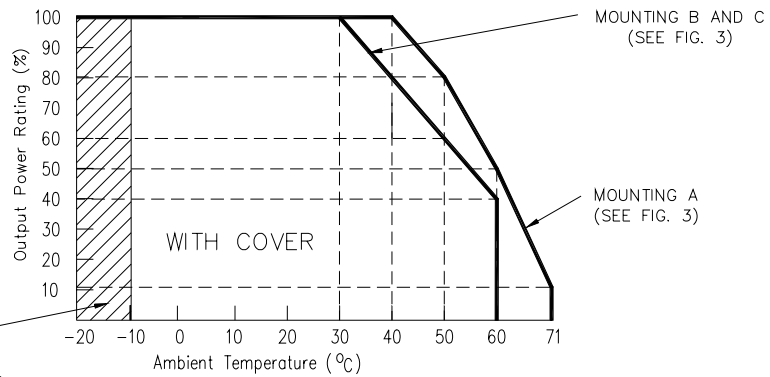

3043018

FIGURE 2. POWER RATING VS. TEMPERATURE

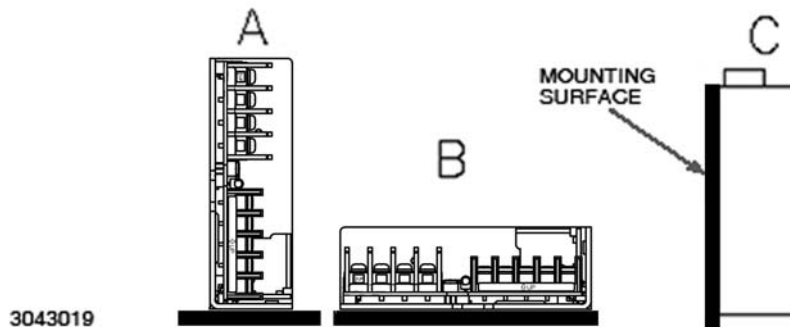

3043019

FIGURE 3. MOUNTING POSITIONS FOR THE RTW 300W POWER SUPPLY

4. OPERATION

Figure 4 shows the location of all operating controls and input/output terminals followed by an explanation of each. The unit is shipped with a shorting connector installed connecting: +RC to -RC and local sensing cables connecting +DC Output with +S and -DC Output with -S for local sensing.

NOTES:

- a. **+S and -S MUST be properly connected for the unit to operate. For local sensing, leave local sensing cables in place (refer to PAR. 6.1). For remote sensing (at the load), refer to PAR. 6.2.**
- b. **If remote ON/OFF is not being used, ±RC pins of either connector CN2 or CN3 must be connected (use shorting connector supplied) for unit to operate.**

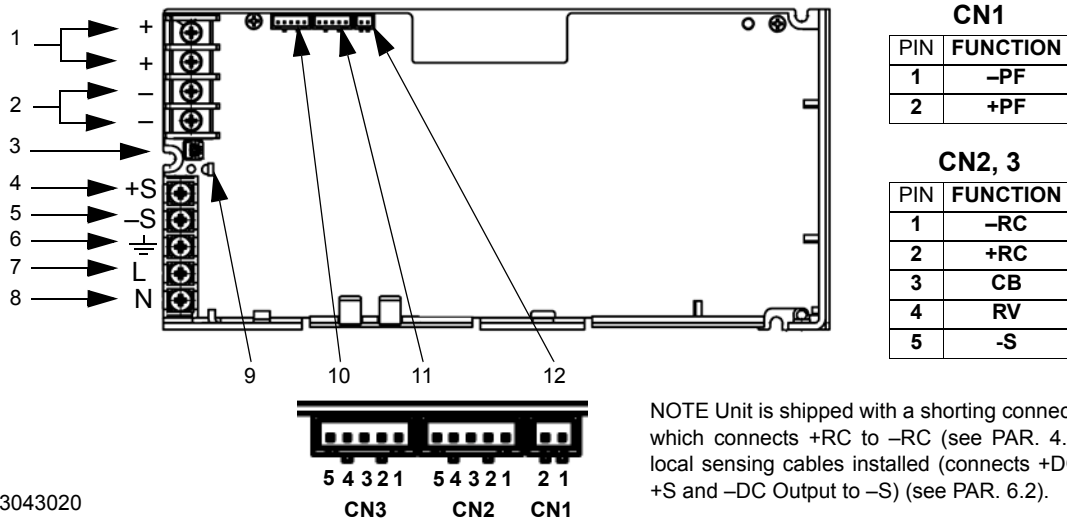

3043020

FIGURE 4. LOCATIONS OF OPERATING CONTROLS, INDICATORS AND TERMINALS

TABLE 3. FUNCTION OF CONTROLS, INDICATORS AND TERMINALS

FIG. 4 INDEX NO.	CONTROL, INDICATOR, TERMINAL	FUNCTION
1, 2	DC Output (+, -)	Connect to load (see Figure 7).
3	Output Voltage Trim Adjust (Vadj)	Adjusts output voltage.
4, 5	Sense (+S, -S)	Used to compensate for voltage drop in the connecting lines from the output terminal to a load; they are connected to \pm DC Output terminals for local sensing (see Figure 7).
6	Ground (earth)	Connect to earth ground. This terminal is connected to the chassis.
7	A-C Input (L)	Connect to AC: 100 to 240V input line.
8	A-C Input (N)	Connect to AC: 100 to 240V input line.
9	Output Voltage On indicator (green)	Green LED lights when output voltage is present.
10, 11	Connector CN3, CN2 (See Table 4 for mating connector part numbers.)	-RC (pin 1) and +RC (pin 2) provide Remote ON-OFF. Output is turned ON-OFF by shorting-opening the RC pins (output OFF when open). Normally, \pm RC pins are shorted with a shorting connector (see PAR. 4.3). CB (Current Balance, pin 3) is used when several power supplies are connected in parallel (see PAR. 6.3). RV (Remote Voltage, pin 4) is used for remotely controlling output voltage (see PAR. 4.2). -S (pin 5) -Signal common functions as the common return for connection of multiple units. (see PAR's 6.3 and 6.4.)
12	Connector CN1	-PF (pin 2) and +PF (pin 1) output an open logic signal if output voltage drops to 80% or lower of a set voltage, or if output voltage is shut down due to overvoltage or over-current protection. (see Figure 6).
	Local Sensing Cable Kit	Connects \pm DC Output to \pm S for local sensing (see Figure 7).
	Shorting Connector	Connects -RC (pin 1) and +RC (pin 2) of connector CN2 or CN3 when not using remote ON-OFF.

TABLE 4. MATING CONNECTORS

Connector Number	Connector Part Number	Socket Housing Part Number	Contact Part Number	MFR
CN1	B2B-XH-2	XHP-2	SXH-001T-P0.6	JST ⁽¹⁾
CN2, CN3	B5B-XH-2	XHP-5	SXH-001T-P0.6	JST ⁽¹⁾

(1) JST= Japan Solderless Terminal Mfg. Co.

4.1 VOLTAGE ADJUSTMENT

Output voltage can be manually adjusted with the voltage adjustment control, Vadj (see Figure 4). To adjust voltage, first place the unit under an operating load, then monitor the (+)S and (-)S Sense terminals with a precision voltmeter and turn the voltage control to the desired operating value (turn clockwise to increase voltage). Refer to Table 1 for the recommended Adjustment Range of all the RTW 300W Models

4.2 REMOTE VOLTAGE CONTROL

By adjusting an external 0-5V voltage source from minimum to maximum, the output voltage can be adjusted. First monitor the \pm S terminals and use the Vadj control to establish the minimum output voltage; turn Vadj counterclockwise to decrease output voltage. Then connect the external voltage source across the RV and -S pins of CN2 or CN3 as shown in Figure 5, using either twisted or shielded wires not more than 2 meters in length. Optional Cable Kit 219-0493 (PAR. 6.6) may facilitate connections. Specifications are met when voltage is within adjustment range in Table 1.

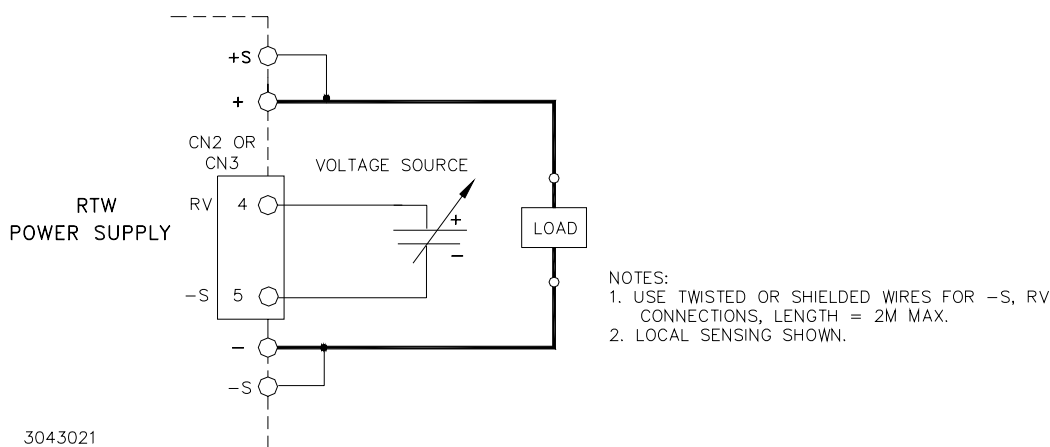

FIGURE 5. CONNECTIONS FOR REMOTE VOLTAGE CONTROL

4.3 REMOTE TURN ON-TURN OFF

When input source power is ON, the output may be turned ON or OFF with the remote control feature using the \pm RC pins of connector CN2 or CN3 (see Figure 4). These pins accept a logic level (2.4V to 24V “high” and 0.0 to 0.4V “low”), or a contact closure. When the \pm RC pins are open, using either a mechanical switch or a high level logic signal, the RTW 300W output is cut OFF. When the RC pins are shorted or at a low logic level, the output returns to within specifications. At low level logic, the maximum source current is 1.6mA and at high level the maximum sink current is 1.0mA. The RC pins must remain shorted if remote ON-OFF is not used; use the shorting connector provided with the unit. Optional Cable Kit 219-0493 (PAR. 6.6) may facilitate connections.

5. ALARM FUNCTIONS

5.1 OVERVOLTAGE PROTECTION

When the output voltage of the RTW 300W Power Supply increases beyond the specified values (see Table 1), the output is cut OFF. To restart (reset) the unit, remove, then reconnect AC input power after about 30 seconds; or open and then reclose the RC pins (see PAR. 4.3).

5.2 CURRENT LIMIT

The unit does not shut down if output current exceeds specifications (see Table 1). Instead, the unit continues to operate, supplying the maximum current, while output voltage is reduced accordingly as long as the output voltage does not drop lower than the undervoltage protection value (see Table 1).

5.3 OPTICAL COUPLER OUTPUT ALARM CIRCUIT

When the output voltage falls to less than about 80 percent of rated output voltage the alarm is activated: a high logic level appears at the \pm PF pins of connector CN1 (see Figure 6). The default state of the alarm is logic low. The sink current is 50mA maximum, the maximum collector to emitter saturation voltage is 0.40 Volts, and the collector to emitter voltage is 40 volts maximum. The PF pins are isolated from the AC input and DC output terminals.

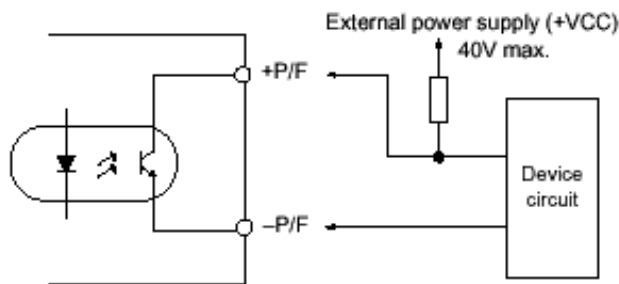

FIGURE 6. OUTPUT ALARM CIRCUIT, OPTICALLY ISOLATED

5.4 UNDERVOLTAGE

If the output voltage of the power supply falls below a preset percentage of the rated output voltage, the power failure alarm will go to the high logic state and the output is cut OFF. Table 1 lists the percentage and the time duration each model will tolerate the undervoltage condition before the output is shut off.

6. LOAD CONNECTION

6.1 CONNECTING THE LOAD USING LOCAL SENSING

To connect the load for local sensing, connect the +S to (+) terminal and -S to (-) terminal. The load is connected across DC output (+) and (-) terminals (see Figure 7).

CAUTION: For 3.3V and 5V models use both (+) and both (-) output terminals to reduce current carried through any one terminal. If current on a single terminal exceeds 40 Amperes, the terminal will overheat and damage the electrolytic capacitor.

6.2 CONNECTING THE LOAD USING REMOTE SENSING

For remote sensing the load is connected as shown in Figure 7. Remote error sensing at the load terminals compensates for a voltage drop in the connecting wires as indicated in Table 2. For remote sensing, the twisted-wire sensing cables shown in Figure 7 must be removed from the +S to (+) and -S to (-) terminals.

NOTE: To prevent oscillations, install one external electrolytic (do NOT use tantalum) capacitor, rated 470 μ F min. between the (+) and +S terminals and one between the (-) and -S terminals (see Figure 7).

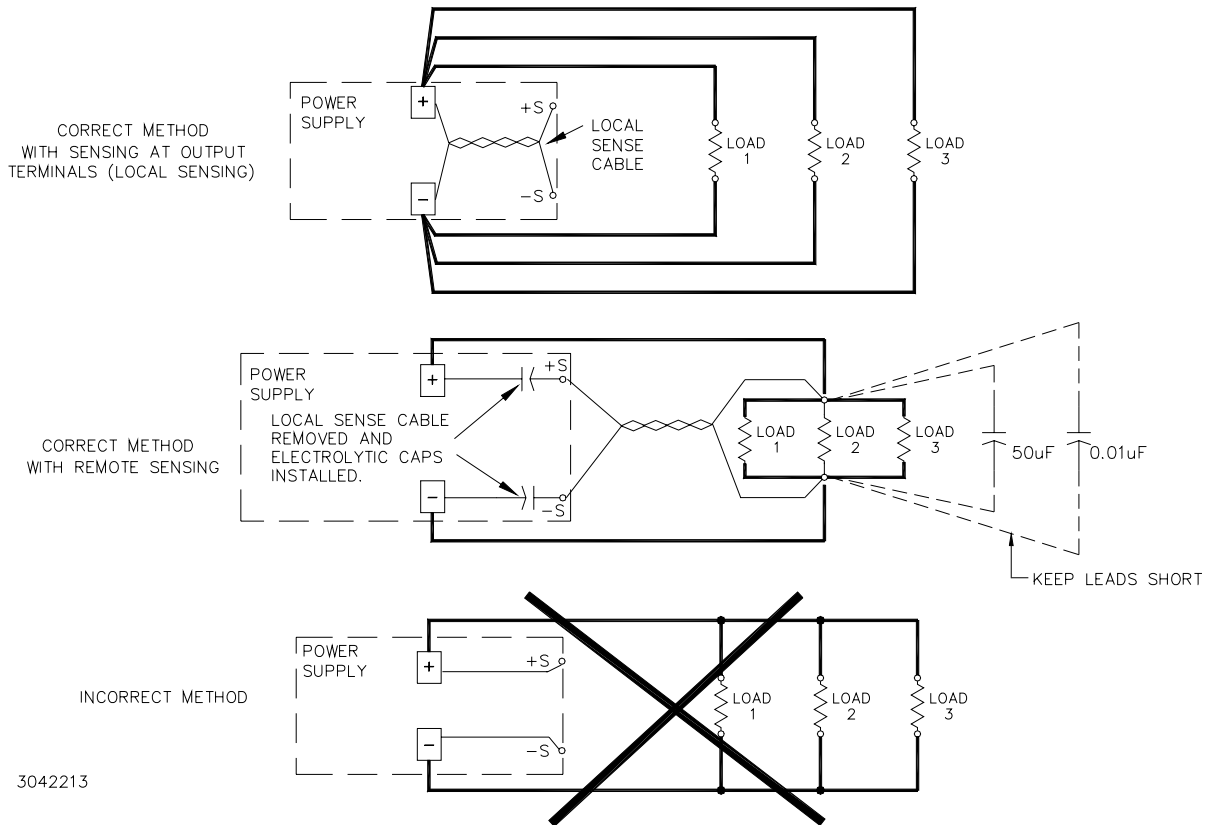

FIGURE 7. CORRECT AND INCORRECT METHODS OF LOAD CONNECTION

6.3 PARALLEL CONNECTION

RTW 300W Power Supplies can be connected in parallel (with or without N+1 redundancy). Use twisted or shielded wire for connection to RV and -S terminals. The impedance of the load wires between each power supply and load should be the same as close as possible.

For a single remote ON-OFF signal to turn off all parallel-connected units, connect together all +RC terminals and connect together all -RC terminals. Figure 8 illustrates connection of up to four (maximum) power supplies in parallel. Output current for a parallel connection operating into a single load is equalized by connecting the CB and -S terminals as shown. Refer to PAR. 6.3.1 for conditions required for proper current equalization (balancing). Optional Cable Kit 219-0497 (PAR. 6.6) may facilitate connections.

N+1 Redundancy. An N+1 system requires one additional power supply than necessary to supply the load. If one of the parallel-connected units fail, the others will continue to provide power to the load without down time. For redundancy, add isolation diodes as shown in Figure 8.

6.3.1 CURRENT BALANCING

Current balancing (equalization) conditions required for up to four RTW 300W units in parallel are:

1. Output current of each power supply should be within 20 to 90% of the total output current rating.
2. The output voltage of any Power Supply individually must be within 2% maximum of the other power supply output voltage setting.

$$\frac{\text{Maximum Voltage} - \text{Minimum Voltage}}{\text{Rated Voltage}} = 2\% \text{ variation of output voltage in each power supply}$$

3. The expected current sharing is such that the output current variation for each power supply is less than or equal to 10% of each power supply rated output current.

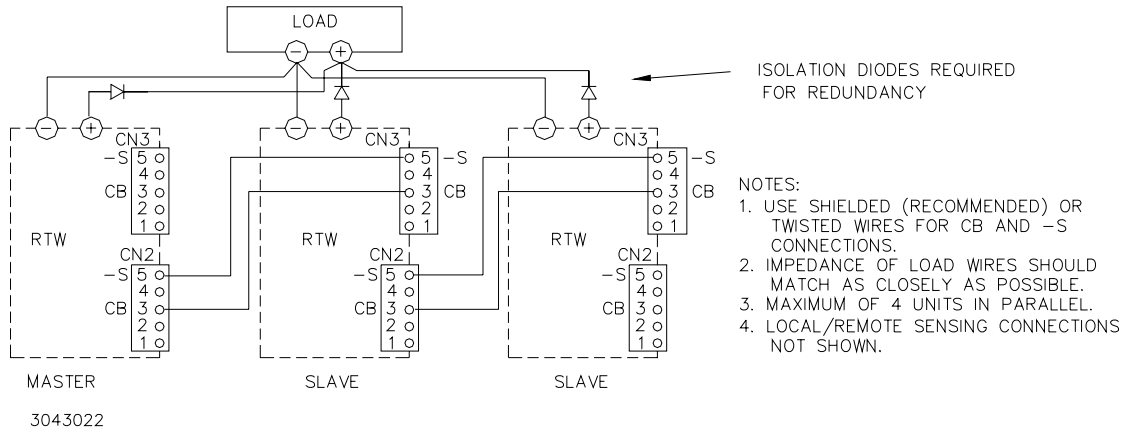

FIGURE 8. PARALLEL CONNECTION WITH CURRENT BALANCING

6.3.2 MASTER-SLAVE CONFIGURATIONS

Master-slave operation allows the output voltage of all the power supplies connected in parallel to be adjusted at the same time by using the Vadj control on the designated master power supply.

6.3.2.1 MASTER-SLAVE, MULTIPLE LOADS

Figure 9 shows the master-slave connection of three power supplies in parallel, each having an independent load, with output voltage controlled by the Vadj control of the master power supply. Use shielded wire (recommended) or twisted wires for connections to RV and -S terminals. If optional Cable Kit 219-0493 (PAR. 6.6) is used, the wire at pin3 (CB) must be cut. NOTE: Vadj control of all slave units must be set to maximum counterclockwise for this configuration to operate properly.

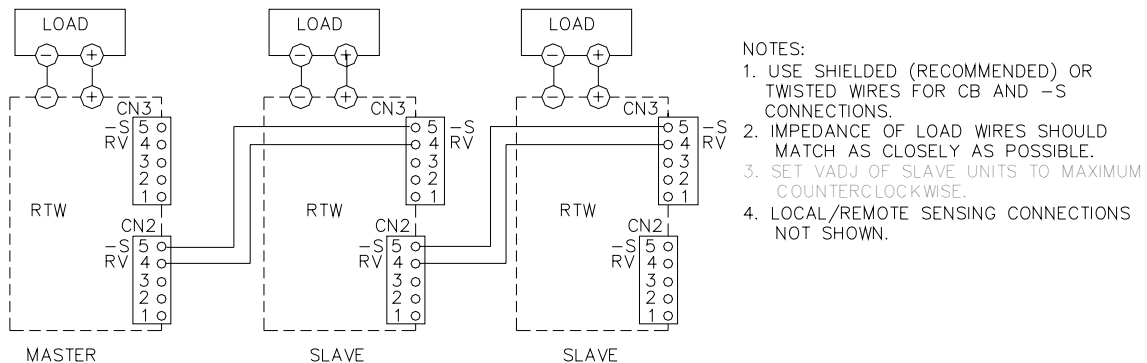

FIGURE 9. PARALLEL CONNECTION, MASTER-SLAVE, MULTIPLE LOADS

6.3.2.2 MASTER-SLAVE, SINGLE LOAD

Figure 10 shows the connection of three power supplies in parallel to a single load. The output voltage of all power supplies is controlled by V_{adj} of the master. Current balancing is implemented to equalize the load current (see PAR. 6.3.1). V_{adj} control of all slave units must be set to maximum counterclockwise for this configuration to operate properly. NOTE: Use shielded wire (recommended) or twisted wires for connections to RV and -S terminals. Match impedance of load wires between each power supply and load by using the same wire lengths and wire sizes. Optional Cable Kit 219-0497 (PAR. 6.6) may facilitate connections.

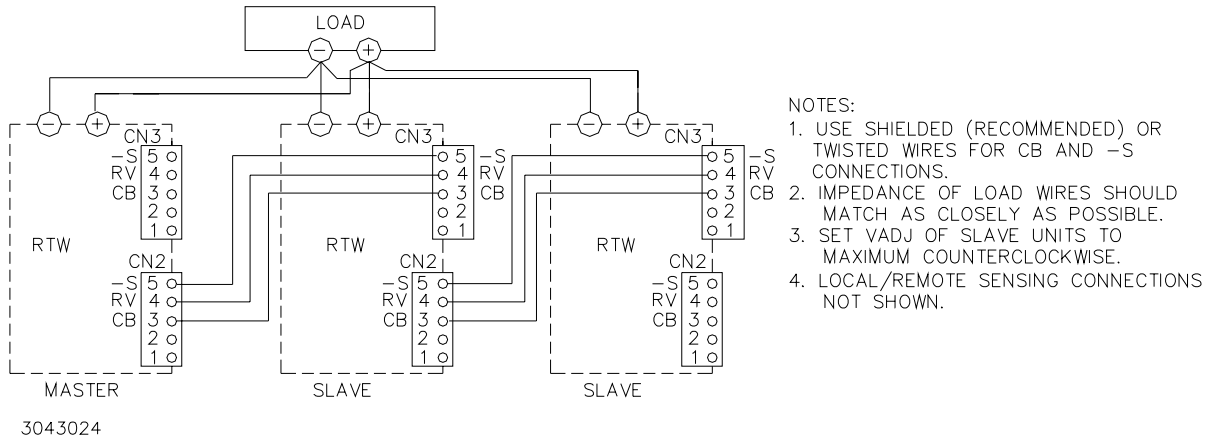

FIGURE 10. PARALLEL CONNECTION, MASTER-SLAVE, SINGLE LOAD

6.4 SERIES CONNECTION

Units may be connected in series to obtain higher voltages. When a number of power supplies are operating in series, the current rating is to be limited to the rating of the power supply with the lowest rating. Each Power Supply in series should be protected by a diode connected in parallel with the output as shown in Figure 11. The diode protects against reverse voltages. It should be rated for typically, $V_{REVERSE} \geq 2 \times \sum V_{OUT}$ of the series connection, $I_{FORWARD} \geq 2 \times I_{OUT}$ of the series connection. Optional Cable Kit 219-0497 (PAR. 6.6) may facilitate CN2/CN3 connections, however the wire at pin 3 (CB) must be cut.

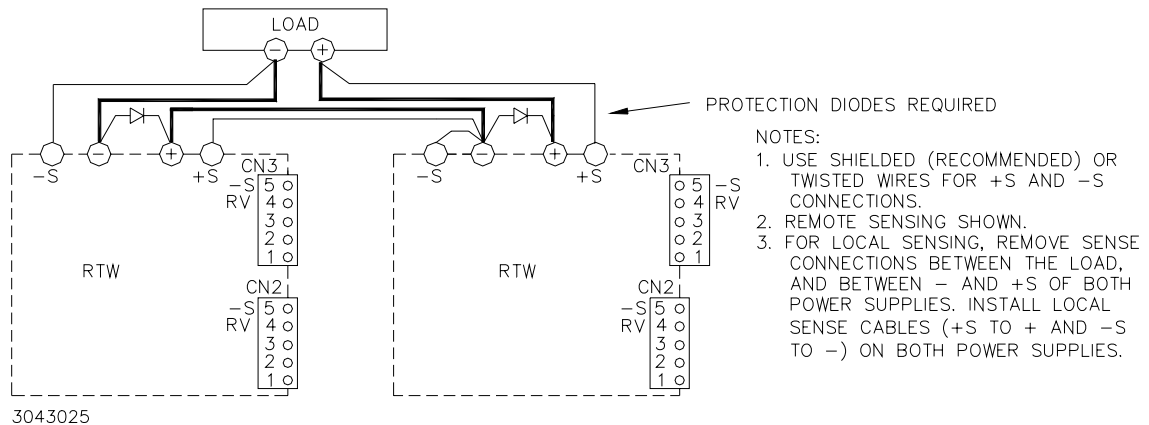

FIGURE 11. SERIES CONNECTION

You must register your product to comply with the terms of the warranty. Either fill out the form below and mail or fax to Kepco, or for rapid on-line registration go to:

<http://www.kepcopower.com/warranty.htm>

PRODUCT PURCHASED:

Model Number) _____

Serial Number _____

PURCHASE INFORMATION:

Date Purchased: _____

Date Received: _____

REQUEST ADDITIONAL INFORMATION

Send complete Catalog

Have Sales Engineer Call

Contact via: E-Mail Telephone Fax S-mail

REGISTER TO:

Registered by: _____

Company Name: _____

Street: _____

City: _____

State: _____

Country: _____

Zip: _____

E-mail: _____

FAX: _____

Phone: _____

WHAT INFLUENCED YOUR CHOICE OF THIS POWER SUPPLY?

Previous Experience (which Kepco Models do you have?) _____

Magazines (which ones?) _____

Trade Shows (which ones?) _____

Directory? _____

Kepco Catalog or Brochure? _____

Sales Representative?

Web Site

Other (please explain): _____

What products would you like to see Kepco make?

CUT HERE

Kepco 5 Year Warranty

This is to certify that we, KEPCO, INC., (hereinafter called "Company"), Flushing, NY 11355 USA, warrants for a period of FIVE YEARS, this instrument known as:

MODEL: _____

SERIAL NO. _____

The Company's products are warranted for a period of five years from date of delivery to be free from defects in materials and workmanship and to conform to the specifications furnished or approved by the Company. Liability under this warranty shall be limited to the repair or replacement of any defective product at Company's option.

If any defect within this warranty appears within the warranty period, the Purchaser shall promptly notify the Company in writing. No material will be accepted for repair or replacement without written authorization of the Company.

Upon such authorization, and in accordance with instructions of the Company, parts or materials for which replacement is requested shall be returned to the Company for examination, with shipping charges prepaid by the Purchaser. Final determination as to whether a product is actually defective rests with the Company.

This warranty does not extend to any product which has been subjected to misuse, neglect, accident, improper installation, or use in violation of instructions furnished by the Company. The warranty does not extend to, or apply to, any unit which has been repaired or altered outside of the Company's factory by persons not expressly approved by the Company.

THE WARRANTY HEREIN CONTAINED IS IN LIEU OF AND EXCLUDES ALL OTHER WARRANTIES, EXPRESS, IMPLIED OR STATUTORY, INCLUDING WITHOUT LIMITATION THE WARRANTY OF MERCHANTABILITY.

THIS KEPCO PRODUCT IS WARRANTED FOR FIVE YEARS!

KEPCO, INC. • 131-38 SANFORD AVENUE, FLUSHING,
NY 11355 USA • Tel. 718-461-7000 • Fax. 718-767-1102
E-mail: hq@kepcopower.com • URL: <http://www.kepcopower.com>



FOLD HERE

Please
place
stamp
here

KEPCO, INC.

131-38 SANFORD AVE.
FLUSHING, NY 11355 USA

CUT HERE