

# QUICK START GUIDE

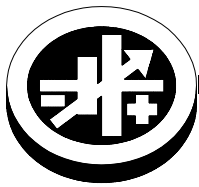

**KEPCO** An ISO 9001 Company.

**HSF**  
-PFC



## SINGLE OUTPUT 3U HOT SWAP PLUG-IN POWER SUPPLIES

### I — INTRODUCTION

**SCOPE OF MANUAL.** This Quick Start Guide covers the installation and operation of the Kepco 3U HSF-PFC Series of Hot Swap Plug-in Power Supplies. Full specifications are listed in the applicable 50W, 100W or 150W HSF-PFC Operator Manual that can be downloaded from the Kepco web site at:

[www.kepcopower.com/support/opmanls.htm#hsfpfc](http://www.kepcopower.com/support/opmanls.htm#hsfpfc)

These power supplies are designed to be installed in Kepco's RA 19-(X)B Rack Adapters: RA 19-6B for up to six 150W units, RA 19-7B for up to three 150W units, and up to four 50W or 100W units and RA 19-8B for up eight 50W or 100W units. The applicable RA 19-(X)B Operator Manual can be downloaded from the Kepco web site at:

[www.kepcopower.com/support/opmanls.htm#ra19-xb](http://www.kepcopower.com/support/opmanls.htm#ra19-xb)

**DESCRIPTION.** The Kepco HSF-PFC Series power supplies come in 50W, 100W and 150W power ratings. Each group has 3.3V, 5V, 12V, 15V, 24V and 48V models (the 100W and 150W groups also have 28V models). Power Factor Correction (PFC) is included in all models.

Units may be operated with a nominal 120V a-c/240V a-c (input voltage range 95 to 264 Va-c), 50-60 Hz (input frequency range 47-440Hz (at 440Hz leakage current exceeds UL/VDE safety spec. limit). They will also operate on 125V to 370V d-c input. Overvoltage protection is provided. Current limiting with automatic recovery from short circuit is featured. Units are convection cooled.

**OPTIONS.** *T option* models (-PFCT) use a Kepco RTW power supply instead of the RKW power supply for improved efficiency, less weight, and the addition of a 28V, 50W model. Specifications and, in some cases, model numbers differ slightly. *C option* (-PFCC) models are identical to the T option, and also include a current sensing resistor, allowing current monitoring within  $\pm 10\%$  (contact Kepco if greater accuracy is required). *X option* models (-PFCX) are identical to the T option, and also include the ability to turn the unit on/off from a remote location. *Y Option* models (-PFCY) are identical to the T option, and also include both the current sensing resistor and remote on/off capabilities.

**TABLE 1. HSF -PFC HOT SWAP MODELS**

POWER RATING	MODELS						
	3.3V	5V	12V	15V	24V	28V	48V
50W	HSF 3.3-10PFC <sup>(1)</sup> HSF 3.3-12PFC <sup>(2)</sup>	HSF 5-10PFC <sup>(3)</sup>	HSF 12-4.3PFC <sup>(3)</sup>	HSF 15-3.5PFC <sup>(3)</sup>	HSF 24-2.2PFC <sup>(3)</sup>	N/A <sup>(4)</sup> HSF 28-1.8PFC <sup>(2)</sup>	HSF 48-1.1PFC <sup>(3)</sup>
100W	HSF 3.3-20PFC <sup>(1)</sup> HSF 3.3-25PFC <sup>(2)</sup>	HSF 5-20PFC <sup>(3)</sup>	HSF 12-8.5PFC <sup>(1)</sup> HSF 12-8.4PFC <sup>(2)</sup>	HSF 15-7PFC <sup>(1)</sup> HSF 15-6.7PFC <sup>(2)</sup>	HSF 24-4.5PFC <sup>(1)</sup> HSF 24-4.2PFC <sup>(2)</sup>	N/A <sup>(4)</sup> HSF 28-3.8PFC <sup>(2)</sup>	HSF 48-2.1PFC <sup>(1)</sup> HSF 48-2PFC <sup>(2)</sup>
150W	HSF 3.3-30PFC <sup>(1)</sup> HSF 3.3-35PFC <sup>(2)</sup>	HSF 5-30PFC <sup>(3)</sup>	HSF 12-13PFC <sup>(1)</sup> HSF 12-12PFC <sup>(2)</sup>	HSF 15-10PFC <sup>(3)</sup>	HSF 24-6.5PFC <sup>(1)</sup> HSF 24-6.3PFC <sup>(2)</sup>	N/A <sup>(4)</sup> HSF 28-5.5PFC <sup>(2)</sup>	HSF 48-3.3PFC <sup>(1)</sup> HSF 48-3.2PFC <sup>(2)</sup>

(1) Standard (no suffix) only. (2) Suffix C, T, X, and Y only. (3) Both standard and suffix C, T, X, and Y. (4) Standard (no suffix) not available.

### II — INSTALLATION

**MOUNTING THE POWER SUPPLY.** Refer to Figure 1 and insert HSF-PFC power supply into selected slot of RA 19-(X)B Rack adapter until power supply front panel is flush with rack adapter chassis and secure with front panel Phillips head mounting screw.

**CONNECTIONS.** All connections are made at the rear panel of the RA 19-(X)B Rack Adapter (see applicable RA 19-(X)B Operator Manual). Connect the load to the applicable  $\pm$  DC OUTPUT terminals. AC input power to each slot is

applied via two INPUT POWER terminal blocks as indicated on the rack adapter rear panel. Make sure to connect the AC input Neutral, Line and Ground wires to the respective terminals of the terminal blocks.

**REMOVAL.** To remove a power supply, first use the POWER switch to turn off the unit. Then loosen the mounting screw and extract the unit from the RA 19-(X)B Rack Adapter.

KEPCO, INC. • 131-38 SANFORD AVENUE • FLUSHING, NY. 11355 U.S.A. • TEL (718) 461-7000 • FAX (718) 767-1102  
<http://www.kepcopower.com> • email: [hq@kepcopower.com](mailto:hq@kepcopower.com)

### III — OPERATION

Turn the unit on using the front panel POWER switch (see Figure 1). **CAUTION: DO NOT repeatedly toggle the POWER on/off switch as this may cause unit to fault.**

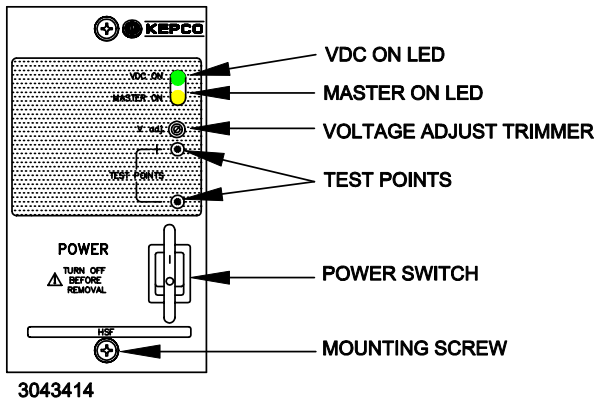

FIGURE 1. COMPONENT LOCATIONS

When output voltage is available, the green VDC ON LED is on. While monitoring output voltage at the front panel test points, the Output Voltage Adjust trimmer allows adjustment of the output voltage.

Master/slave parallel configurations of one or more HSF-PFC power supplies are covered in the applicable RA 19-(X)B Rack Adapter manual.

The MASTER ON LED (amber) goes on under any of the following three conditions:

- Independent operation.
- Operation in a parallel master/slave configuration to indicate which unit is the master
- Operation in a parallel master/slave configuration to indicate that a slave unit is no longer within the proper specifications for paralleled units. Slave 1 should be optimally adjusted to 40mV less than master, slave 2 adjusted to 40mV less than slave 1, etc. The maximum allowable difference between paralleled units is 250mv. The minimum allowable difference between paralleled units is 25mV. If a slave exceeds these limits, the MASTER ON light goes on.

NOTE: MASTER ON LED not used on 3.3V model: always OFF.

The following features of the HSF-PFC power supplies are covered in the applicable Operator's manual referenced on page 1.

- Parallel Operation
- Forced Current Sharing
- Current Monitoring (Option C and Y only)
- Remote On/Off (option X and Y only)
- Alarms
- Keying of rack adapter slots by voltage

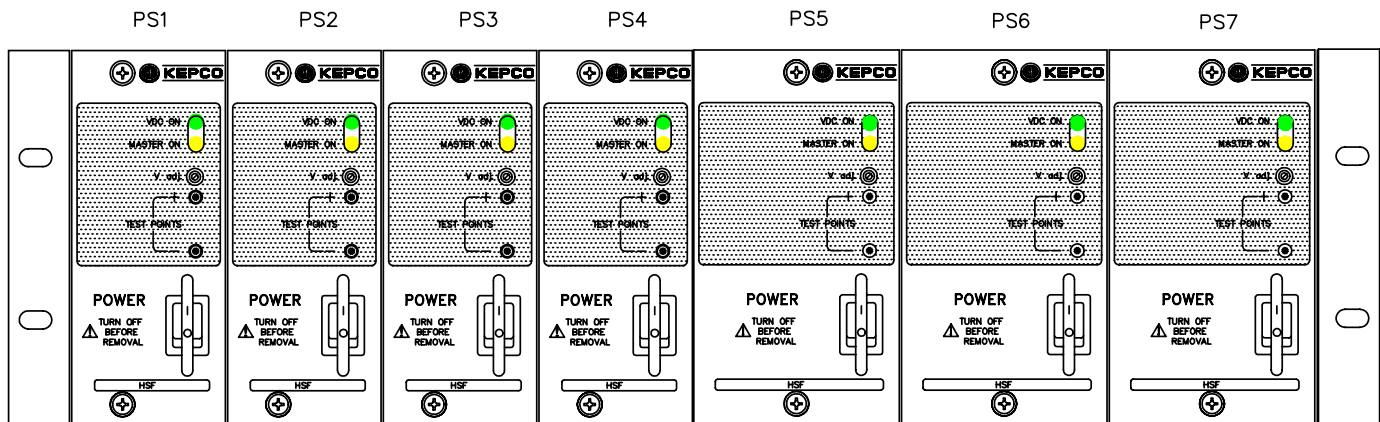

FIGURE 2. HSF -PFC MODELS INSTALLED IN RA 19-7B RACK ADAPTER (FOUR 50W OR 100W MODELS IN SLOTS 1 TO 4 AND THREE 150W MODELS IN SLOTS 5 TO 7)