

QUICK START GUIDE

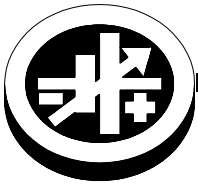

KEPCO An ISO 9001 Company.



SINGLE OUTPUT PROGRAMMABLE POWER SUPPLIES

I — INTRODUCTION

SCOPE OF MANUAL This Quick Start Guide covers the installation and operation of the Kepco HSP Series of voltage and current stabilized d-c power supplies. Full specifications are listed in the applicable Operator's Manual that can be downloaded from the Kepco web site at www.kepcopower.com/support/opmanls.htm/#hsp

FACTORY DEFAULTS This guide covers only units as shipped from the factory with the three DIP switches set to default configuration (see Figure 1). For other configurations, refer to HSP Operator Manual.

DESCRIPTION The HSP power supply (Figure 1-1) is basically a voltage and current stabilized d-c source with a relatively sharp crossover between voltage and current mode operation.

HSP power supplies are nominally rated at either 1000 or 1500 Watts of output power, and include active power factor correction (PFC). HSP 1000W power supplies are designed to operate over the universal a-c power mains voltage range of 90-277V (47-63Hz), with operation from 125-420V d-c also available. HSP 1500W products provide full power over the a-c mains range of range of 180-277V a-c, and 1000W output power from 90-132V a-c; contact Kepco for information on operation over other source voltage ranges. Cooling is provided via an internal d-c fan.

HSP permits adjustment of both output voltage (V_O) and current limit (I_{MAX}), either by internal (front panel pot) or external (resistance or voltage) methods, selected via DIP switches accessed through the top of the unit. Protection against overvoltage, overcurrent and overtemperature failures is provided.

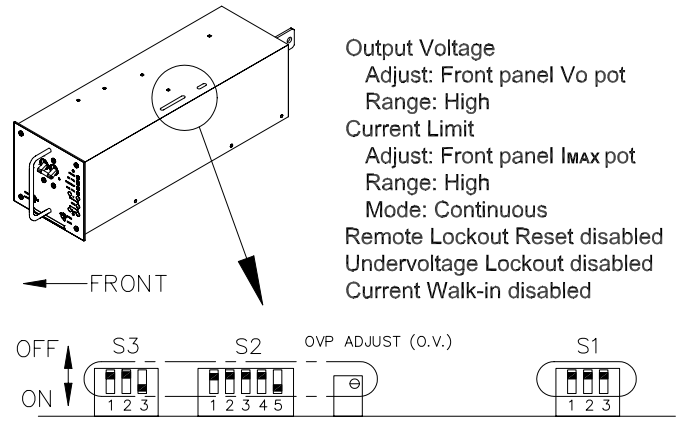

3043521

FIGURE 1. DIP SWITCH FACTORY DEFAULTS

The HSP power supply is specifically designed for use with Kepco RA 60 or similar plug-in rack adapters as a hot replaceable module in a redundant power system. Bench top operation is also supported. Forced current sharing and output blocking diodes enhance power system reliability. Mechanical keying eliminates the risk of incorrect module insertion. Tool-operated latches on the front panel guard against casual removal of an operating module.

OPTIONS M models include a digital meter which displays either voltage or current as determined by a front panel switch. Another switch allows display of either actual HSP Output or the setpoint. B models are intended for battery charging applications, and include a Float/Equalize switch to preset two different voltage values using two separate front panel adjustment pots.

TABLE 1. HSP SERIES MODELS

MODELS	3.3V	5V	12V	15V	24V	28V	48V
1000W	HSP 3.3-230R	HSP 5-200R	HSP 12-84R	HSP 15-66R	HSP 24-42R	HSP 28-36R	HSP 48-21R
1500W	N/A	N/A	N/A	N/A	HSP 24-60R	HSP 28-53R	HSP 48-30R

NOTE: Options include suffix M or B: M for meter; B for battery charger.

II — INSTALLATION

KEYING. The units are keyed by voltage at the factory. Refer to the Operator Manual for details.

MOUNTING THE POWER SUPPLY To insert in a Kepco Rack Adapter, release the two cap head screw retaining latches (see Figure 4) by loosening the cap-head screw approximately 1/2 turn CCW (use 5/32" hex key) and slide to open (up) position. Insert power supply in the slot, then retighten the cap-head screws CW until snug. **DO NOT OVERTIGHTEN!** To release, follow the same procedure, except lift the latch to the top of the slot. Be sure to move the latch completely up or down to ensure full engagement/disengagement of the latching mechanism. When HSP is not installed in rack adapter, secure latch in open (up) position to prevent damage.

To use as a fixed, rack-mounted unit, see Operator manual for details and accessories.

For all installations, provide adequate clearance around air inlet and exhaust locations.

CONNECTIONS: Figure 2 shows proper connection of one or more loads using either remote or local sensing. **If local or remote sensing is not configured, the unit will not work properly.** Observe polarities: negative sensing wire must be connected to negative load wire, and positive sensing wire to positive load wire. When used with plug-in rack adapters, local sense wires must be connected from the I/O connector to the ± studs of the rack adapter.

Load connections to the HSP power supply are via bus bars protruding from the rear panel (see Figure 2) or via the rack adapter output studs.

Load cable or bus bar attachment should use either the clearance hole of the HSP bus bar, using a 5/16" UNC nut, bolt and lockwasher, or the rack adapter studs using hardware supplied with the rack adapter. The proper hardware is critical to maintaining intimate contact between the load conductor and output bus bar.

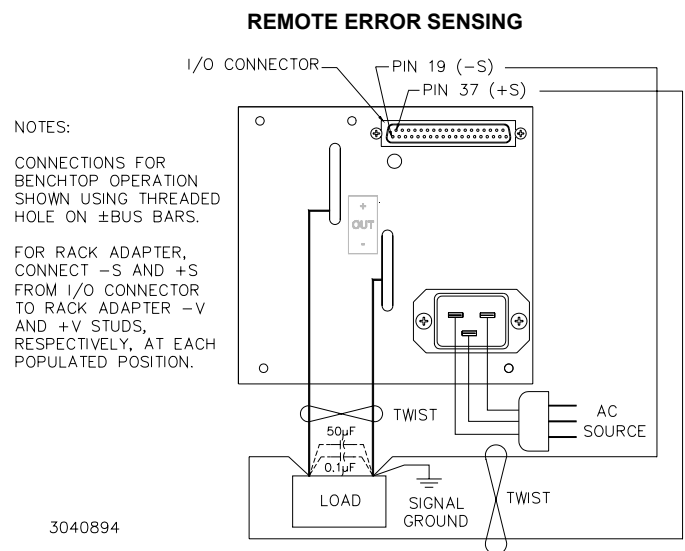
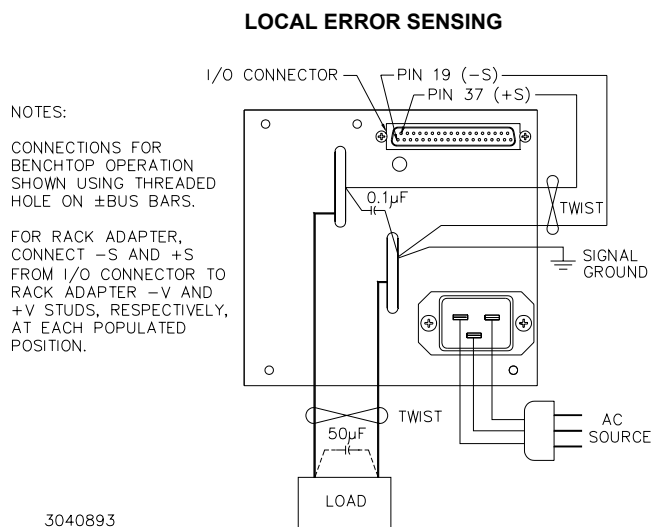

FIGURE 2. LOAD CONNECTIONS

PRELIMINARY ELECTRICAL CHECK A simple operational check after unpacking and before equipment installation is advisable to ascertain whether the power supply has suffered damage resulting from shipping.

1. **Power supply will not operate unless remote sense lines are properly connected to output terminals!** Connect remote sense terminals to output bus bars using mating I/O Connector (Kepco P/N 142-0422) or other means as shown in Figure 2.
2. Connect power supply to source power. Connection can be made using either a North American linecord set (Kepco P/N 118-0776) or using a custom linecord

terminated at one end with an IEC 320/C19 plug (Kepco P/N 142-0381).

3. Connect a static load, R, across output terminals. Load value is determined by HSP nominal output voltage and must be capable of handling 2% of power supply output rating (20 watts minimum). R is calculated as **approximately** equal to $\text{output voltage}^2/20$ ($R = E^2/P$). For example, for the HSP 48-21, $R = 48^2/20 = 115.2$; use load of 120 ohms, 20W.
4. **CAUTION: DO NOT repeatedly toggle circuit breaker as this may damage unit.** Set Power ON/OFF circuit breaker on front panel to ON. If actuator

does not lock when released, wait a few seconds before trying again. The circuit breaker is "trip-free" design; if overload exists, contacts cannot be held closed by actuator. Verify that POWER indicator is lit, and that all other front panel indicators are not lit.

- Using a DVM, measure voltage across output bus bars; this voltage is factory set to value shown in Table 1. If necessary, adjust output voltage using V_O trim pot accessed through front panel.
- Using DVM, measure voltage across test points V_O and COM; it should read 1/10 of output voltage measured in step 5 above, $\pm 1\%$.
- Using DVM, measure voltage across test points I_{MAX} and COM. This voltage is factory adjusted to 10.0V, and corresponds to 100% of maximum current. Refer to Operator manual for adjustment.

III — OPERATION

CAUTION: DO NOT repeatedly toggle the circuit breaker/switch as this may damage the unit. Set Power ON/OFF circuit breaker to ON. When output voltage is available, the green POWER LED is on (see Figure 4).

OUTPUT VOLTAGE PROGRAMMING Monitor output voltage setpoint across V_O and COM jacks while adjusting V_O pot on front panel. Voltage across V_O and COM represents 1/10 of the programmed output voltage. As an example, V_O of 4.63V corresponds to a programmed output voltage of 46.3V $\pm 1\%$. This relationship is constant, regardless of the programming range selected.

Default programming resolution is set to high range: output can be adjusted to 110% of nominal V_O for 3.3V through 28V models, 125% of nominal V_O for 48V models. For low range (which offers increased resolution, while limiting output to V_O), or for external voltage programming using either resistance or voltage refer to Operator manual.

For metered (M option) units, if the V/A switch is set to V, actual output voltage is displayed on the meter in Volts. While the ACTUAL/SETPOINTS switch is held in, the programmed output voltage setpoint is displayed in Volts.

CURRENT LIMIT PROGRAMMING Monitor current limit setpoint across I_{MAX} and COM jacks while adjusting I_{MAX} pot on front panel. Voltage across I_{MAX} and COM represents the percentage of available power supply current as a percentage of rated current, with 10V corresponding to 100%. Available current is defined as the maximum current limit available based on the programming range. This voltage is always based on a 0-10V scale, regardless of the range selected. For example, $I_{MAX} = 6.2V$ corresponds to 62% of the maximum programmable current. For the low

- Verify that front panel indicators still appear as in step 4 above.
- Disconnect sense lines with power supply still operating (remove mating I/O connector or open sense line connected to pin 37. Verify that HSP output turns off, and DC FAIL indicator is now lit along with POWER indicator. (NOTE: At no load the output voltage will drop slowly.) Turn circuit breaker off and wait until DC FAIL indicator blinks. Reconnect sense lines, then turn circuit breaker back on. Verify that output voltage returns to value measured in step 5 above, and that indicator LEDs appear as in step 4 above.
- Turn off front panel circuit breaker and remove source power connection.

programming range, this corresponds to 62% of the rated module current, but for the high programming range the number is 62% of 110%, or 68.2% of rated module current. Current setpoint monitor accuracy is $\pm 5\%$.

Minimum programmable current limit is 50-60% of nominal. Default programming resolution is set to high range: current limit can be adjusted to 110% of nominal I_O . For low range (which offers increased resolution, while limiting output to I_O), or for external programming using voltage source refer to Operator manual.

For metered (M option) units, if the V/A switch is set to A, actual output current is displayed on the meter in Amperes. While the ACTUAL/SETPOINTS switch is held in, the programmed current limit is displayed in Amperes.

OVERVOLTAGE PROTECTION The overvoltage protection (OVP) circuitry latches the output regulator off if output voltage rises above a predetermined level. To reset, remove source power for a minimum of 30 seconds (refer to Operator manual to enable remote reset). The trip level is preset at the factory for 130% of the nominal output voltage. The trip point can be adjusted from 100% to 140% of the nominal output (except Model HSP 48-21, which can be adjusted from 100% to 160% of the nominal output). To alter the preset OVP trip point, refer to the Operator manual.

CURRENT LIMIT CHARACTERISTIC The factory default setting is Continuous Limiting: When the output current of the power supply reaches the programmed current limit, the output regulator switches to current mode operation and maintains the output current by modulating output voltage. Current mode is maintained indefinitely, and

recovery to voltage regulation mode is automatic upon reduction of output current below the current limit point.

Current Limit can also be set to Undervoltage Lockout: if current mode is maintained for more than 15 seconds, the output is turned off, and source power must be recycled to restart the unit. Refer to Operator manual for details.

OTHER FEATURES The following features of the HSP power supplies are covered in detail in the Operator manual:

- Parallel Operation, including load sharing requirements.
- Remote Inhibit, Remote Reset
- Remote Voltage and Current Limit adjustment
- Protection Circuits
- Status Flags and Indicators
- Load Monitor (Current)
- Current "Walk-In" for battery charging applications
- Load monitor
- Auxiliary supply
- Keying
- I/O Connector pin functions
- Options

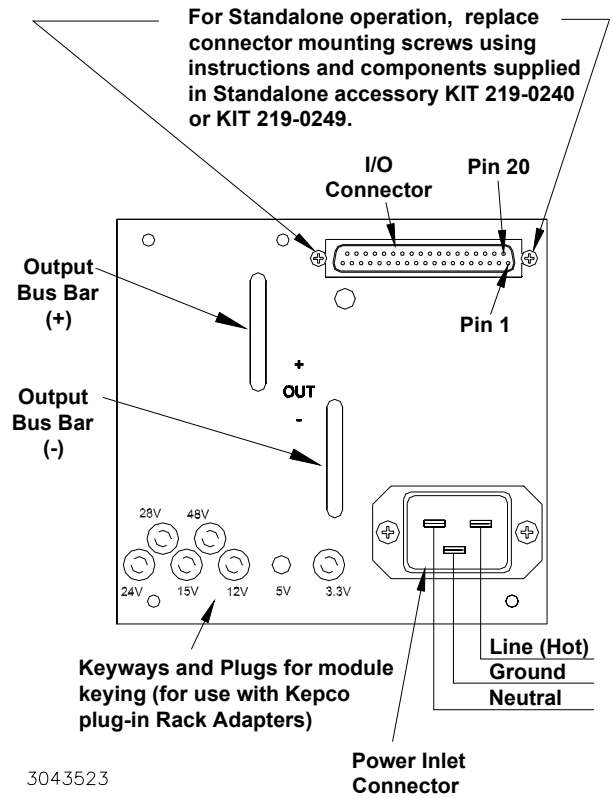

FIGURE 3. HSP SERIES REAR PANEL CONNECTIONS

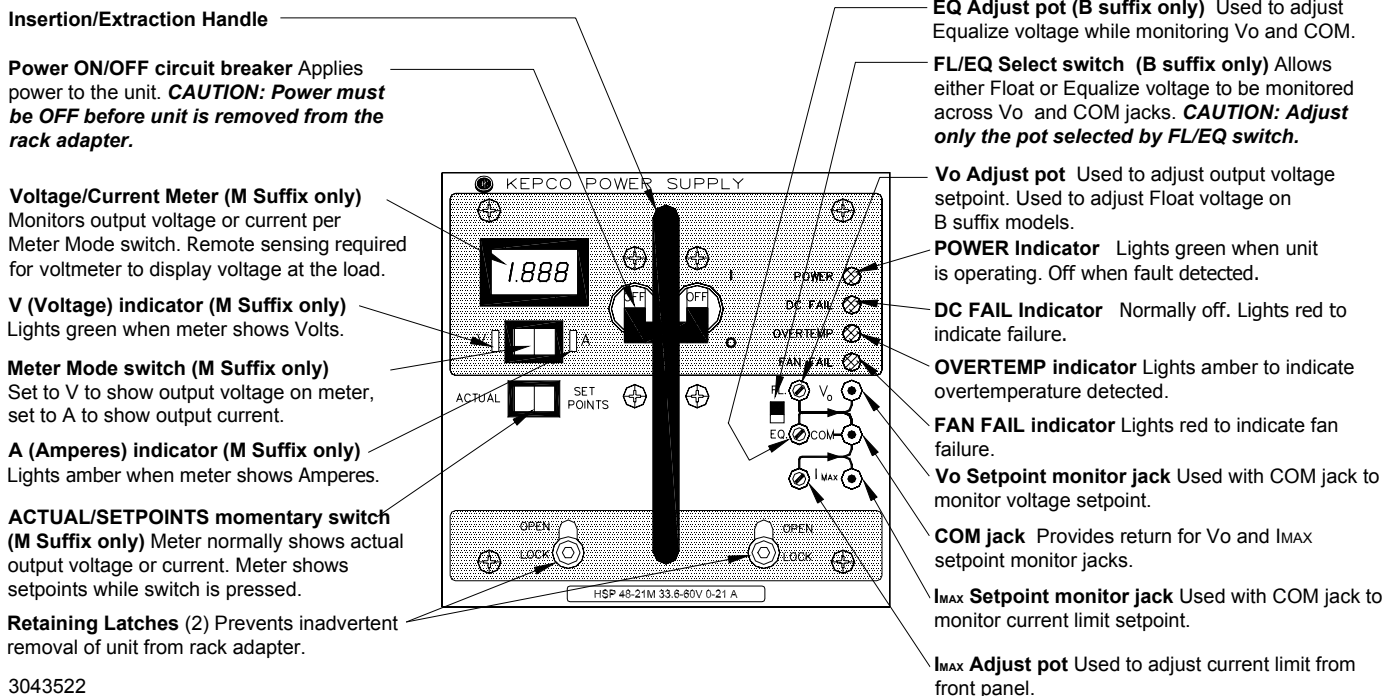

FIGURE 4. COMPONENT LOCATIONS