

INSTRUCTION MANUAL



KEPCO An ISO 9001 Company.

**KIT
DIN AK
-350/450S**

DIN-RAIL MOUNTING KIT FOR SERIES AK-350/AK-450

DESCRIPTION. Kepco KIT, Model DIN AK-350/450S contains two preassembled mounting clips and associated hardware used to install AK-350 and AK-450 Series power supplies on a DIN rail. The "S" suffix is for mounting along the short dimension (width) as shown in Figure 1. Outline dimensions are shown in Figure 4.

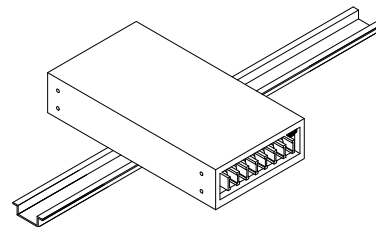

3043853

FIGURE 1. S SUFFIX ORIENTATION

TABLE 1. COMPONENTS SUPPLIED

KIT MODEL NO.	MOUNTING PLATE (QTY 2) PART NO.	CLIP (QTY 2) PART NO.	SCREW (QTY 4) PART NO.	LOCK-WASHER (QTY 4) PART NO.	FLAT WASHER (QTY 8) PART NO.	NUT (QTY 4) PART NO.	SCREW (QTY 4) PART NO.
DIN AK-350/450S	128-2439	108-0362	101-0463 (M4 X 8 FLPH)	103-0017 (NO. 8, Int. Tooth)	103-0028 (NO. 6)	102-0004 (Hex, 1/4" x 6-32)	101-0408 (FH 6-32 x 5/16")

INSTALLING KIT. Attach the preassembled mounting clips to the power supply using the hardware supplied (see Figure 3). The clips may be mounted with the release lever on either side to facilitate removal.

INSTALLING POWER SUPPLY ON DIN RAIL. To mount the power supply on the rail insert one end of both clamps under one edge of the rail, then snap the other end of the two clips into place (see Figure 2A).

REMOVING POWER SUPPLY FROM DIN RAIL. While grasping the power supply with one hand, use a screwdriver to apply leverage towards the right as shown in Figure 2B to disengage each clip from the rail. Where mounting clips are close together, it may be necessary to apply leverage with two screwdrivers simultaneously.

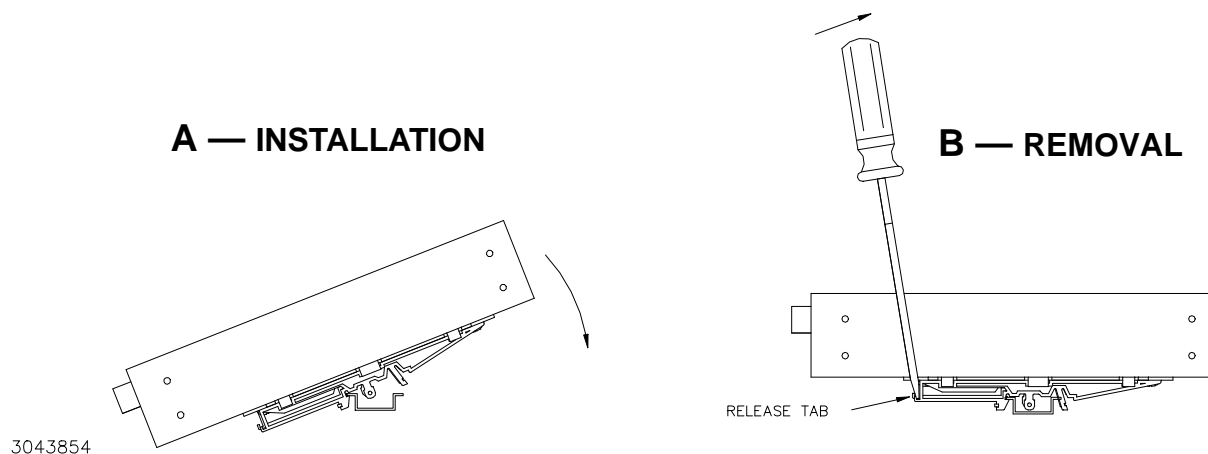
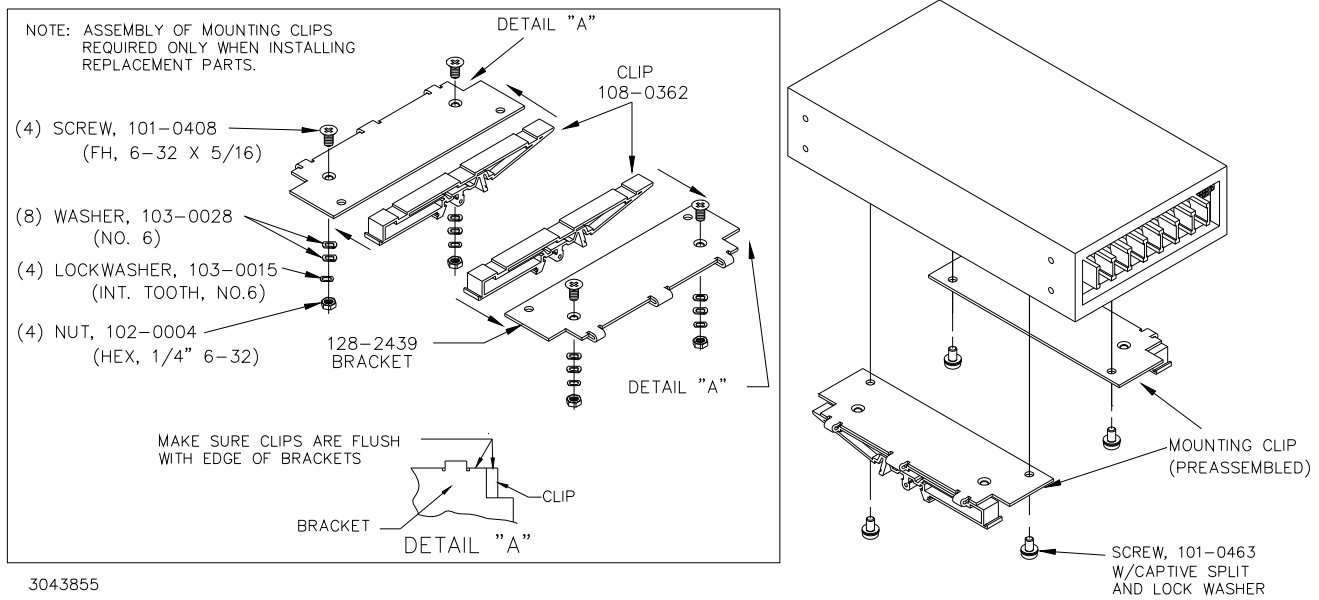

FIGURE 2. INSTALLATION AND REMOVAL OF POWER SUPPLY FROM DIN RAIL

KEPCO, INC. ● 131-38 SANFORD AVENUE ● FLUSHING, NY. 11355 U.S.A. ● TEL (718) 461-7000 ● FAX (718) 767-1102
<http://www.kepcopower.com> ● email: hq@kepcopower.com



3043855

FIGURE 3. INSTALLATION OF KIT ON AK-350 OR AK-450 POWER SUPPLY

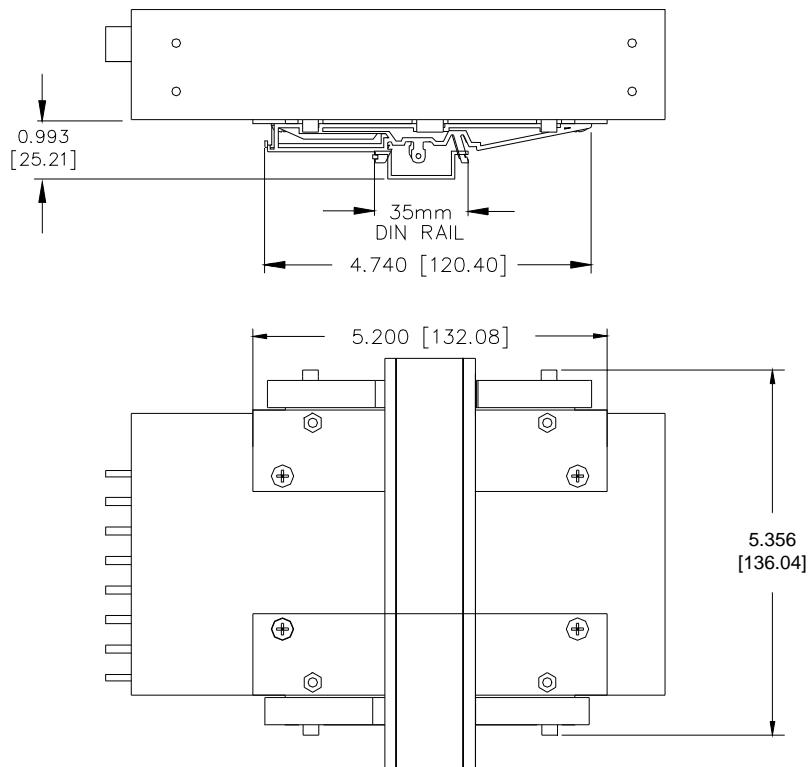

3043856

FIGURE 4. AK-350 OR AK-450 POWER SUPPLY WITH KIT INSTALLED, OUTLINE DIMENSIONS