

OPERATOR'S MANUAL

BOP 5-20DL, BOP 5-30DL

BIPOLAR OPERATIONAL POWER SUPPLY

100W, 150W

KEPCO INC.

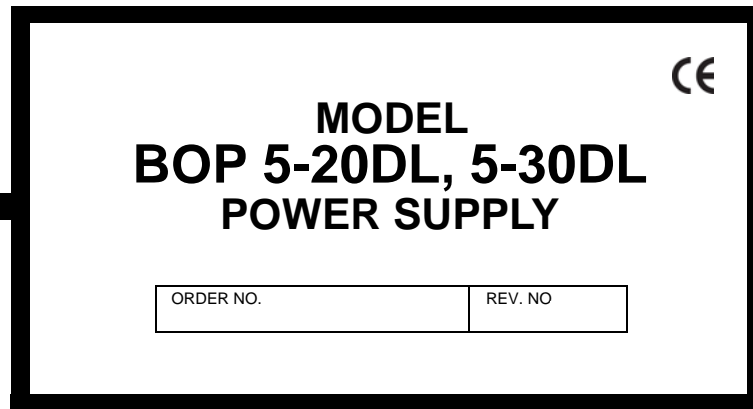

IMPORTANT NOTES:

- 1) This manual is valid for the following Model and associated serial numbers:

MODEL	SERIAL NO.	REV. NO.
-------	------------	----------
- 2) A Change Page may be included at the end of the manual. All applicable changes and revision number changes are documented with reference to the equipment serial numbers. Before using this Instruction Manual, check your equipment serial number to identify your model. If in doubt, contact your nearest Kepco Representative, or the Kepco Documentation Office in New York, (718) 461-7000, requesting the correct revision for your particular model and serial number.
- 3) The contents of this manual are protected by copyright. Reproduction of any part can be made only with the specific written permission of Kepco, Inc.

Data subject to change without notice.

©2017, KEPCO, INC
P/N 243-1367-r5



TABLE OF CONTENTS

SECTION	PAGE
SECTION 1 - INTRODUCTION	
1.1	Scope of Manual..... 1-1
1.2	General Description..... 1-1
1.3	Electrical Specifications, General..... 1-1
1.3.1	Static Specifications..... 1-5
1.3.2	Dynamic Specifications..... 1-6
1.4	Miscellaneous Features..... 1-6
1.4.1	Output Range..... 1-6
1.4.2	Rear Programming Features..... 1-6
1.4.3	Remote ON-OFF Feature..... 1-10
1.4.4	Load Reactance..... 1-10
1.4.4.1	Driving an Inductive Load in Current Mode..... 1-10
1.4.4.2	Driving a Capacitive Load in Voltage Mode..... 1-10
1.4.5	Remote Turn-off..... 1-11
1.4.6	Circuit Breaker Shutdown Prevention (at Power Loss) Circuit..... 1-11
1.4.7	References..... 1-11
1.4.8	Series Or Parallel Operation..... 1-11
1.4.9	Voltage Control Channel..... 1-11
1.4.10	Mode Switch..... 1-11
1.4.11	Current Control Channel..... 1-11
1.4.12	Bounding..... 1-11
1.4.13	Mode Lights..... 1-12
1.4.14	Remote (W/ DIG ON) / Out ON (W/ DIG OFF) LED..... 1-12
1.4.15	Standards..... 1-12
1.5	Mechanical Specifications..... 1-12
1.6	Equipment Supplied..... 1-12
1.7	Accessories..... 1-13
1.8	Safety..... 1-13
SECTION 2 - INSTALLATION	
2.1	Unpacking and Inspection..... 2-1
2.2	Terminations, Controls and Indicators..... 2-1
2.3	A-C Input Requirements..... 2-3
2.4	Cooling..... 2-4
2.5	Preliminary Checkout..... 2-4
2.6	Installation of Full-rack BOP Models..... 2-6
2.6.1	Slide Installation..... 2-6
2.7	Load Connection..... 2-7
2.7.1	Load Connection, Local Sensing..... 2-7
2.7.2	Load Connection, Remote Sensing..... 2-8
2.7.3	A-c Ground..... 2-8
2.7.4	D-c Ground..... 2-8
SECTION 3 - OPERATION	
3.1	Introduction..... 3-1
3.2	Power Supply Basics..... 3-1
3.2.1	External Programming Resistors..... 3-2
3.2.2	Active Programming Sources..... 3-3
3.2.3	External Leads..... 3-3
3.2.4	External Voltage Monitor..... 3-3
3.2.5	External Current Monitor..... 3-3
3.3	Local (Front Panel) Output Control..... 3-3
3.3.1	Voltage Mode Operation with Current Limiting..... 3-3
3.3.2	Local Control of Current Limiting..... 3-5
3.3.3	Current Mode Operation with Voltage Limiting..... 3-5
3.3.4	Local Control of Voltage Limiting..... 3-7

TABLE OF CONTENTS

SECTION	PAGE
3.4 Remote Control of Voltage Channel	3-7
3.4.1 Remote Voltage Control Using Resistance (Potentiometer).....	3-8
3.4.2 Remote Voltage Control Using Resistance (Decade Box)	3-8
3.4.3 Remote Voltage Control Using D-C Signal Voltage.....	3-9
3.4.4 Using the BOP as a Voltage Amplifier	3-12
3.4.5 Remote Control of Current Limiting	3-14
3.5 Remote Control of Current Control Channel	3-15
3.5.1 Remote Current Control Using Resistance (Potentiometer).....	3-16
3.5.2 Remote Current Control Using Resistance (Decade Box).....	3-16
3.5.3 Remote Current Control Using D-C Signal Voltage.....	3-17
3.5.4 Using the BOP as a Current Amplifier	3-18
3.5.5 Remote Control of Voltage Limiting	3-19
3.6 Series and Parallel Connection of BOP Power Supplies	3-21
3.6.1 Series Connection, Master/slave Operation	3-21
3.6.2 Circuit Breaker Control Circuit	3-23
3.6.3 Parallel Connection, Master/Slave Operation.....	3-24
3.7 Indicator And Flag Logic Circuit	3-27
3.8 Digital Control of BOP Power Supplies	3-28

SECTION 4 - INTERNAL ADJUSTMENTS AND CALIBRATION

4.1 General	4-1
4.2 Equipment Required	4-1
4.2.1 Adjustment of (\pm) 10 Volt Calibration Controls (A1R31, A1R32)	4-2
4.2.2 Uncommitted Amplifier "A" Zero Adjustment (A1R41)	4-3
4.2.3 Uncommitted Amplifier "B" Zero Adjustment (A1R42)	4-3
4.2.4 Adjustment of Ammeter Zero Control (A1R50).....	4-3
4.2.5 Adjustment of I_O -OFF Zero (A1R133) and E_O -OFF Zero (A1R136).....	4-4
4.2.6 Voltage Channel Zero Adjustment (A1R81)	4-4
4.2.7 Current Channel Zero Adjustment (A1R83).....	4-5
4.2.8 Calibration of I_O Full Scale Output Current (A3R316).....	4-5

LIST OF FIGURES

FIGURE	TITLE	PAGE
1-2	BOP Output Characteristic.....	1-7
1-3	BOP Output WaveForm with Phase Shift	1-7
1-4	Boundaries and Limits	1-12
1-5	Mechanical Outline Drawing, BOP 5-20DL, BOP 5-30DL.....	2-15
2-1	BOP Terminations and Controls, Front Panel.....	2-1
2-2	BOP Terminations and Controls, Rear Panel	2-3
2-3	A-C Source Voltage Selection	2-3
2-4	Slide Installation on Full-rack Units.....	2-7
2-5	Load Connection Using Local Sensing at Rear Panel	2-9
2-6	Load Connection Using Local Sensing at Front Panel	2-9
2-7	Load Connection Using Remote Sensing at Rear Panel	2-10
2-8	Load Connection Using Remote Sensing at Front Panel	2-10
3-1	BOP Voltage Control Channel (Local Control, Local Sensing)	3-4
3-2	BOP (\pm) Current Limiting Circuit (Local Control, Local Sensing)	3-5
3-3	BOP Current Control Channel (Local Control, Local Sensing)	3-6
3-4	BOP (\pm) Voltage Limiting Circuit (Local Control, Local Sensing)	3-7
3-5	Remote Potentiometer Control of D-C Output Voltage	3-8
3-6	Remote D-C Output Voltage Control Using Two-Terminal Resistance (Decade).....	3-9
3-7	Digital Control of the D-C Output Voltage	3-10
3-8	D-C Output Voltage Control with Non-inverting Configuration and High Impedance $\pm 1V$ Signal Source... ..	3-11
3-9	Graphs Of Possible Input/output Waveshapes	3-12
3-10	Basic Programming Circuit for Use of BOP as Bipolar Amplifier (Voltage Mode).....	3-13
3-11	Programming Circuit for Driving Output Voltage with.....	3-14
3-12	Symmetrical Remote Control of the Current Limits.....	3-15
3-13	Independent Remote Control of $+ I_O$ and $- I_O$ Limits.....	3-15
3-14	Remote Potentiometer Control of the BOP Output Current	3-16
3-15	Remote D-C Output Current Control Using Two-Terminal Resistance (Decade)	3-16
3-16	Digital Control of Output Current.....	3-17
3-17	BOP Output Current Control with Non-inverting Configuration and High Impedance (± 1 Volt Signal Source	3-17
3-18	Basic Programming Circuit for BOP as Bipolar Current-stabilized Amplifier.....	3-18
3-19	Programming Circuit for Driving Output Current with Bipolar Signal Less Than $\pm 10V$	3-18
3-20	Programming Circuit for Driving Output Current with a High Impedance Source	3-19
3-21	Symmetrical Remote Control of Voltage Limit	3-20
3-22	Independent Remote Control of $+E_O$ and $-E_O$ Voltage Limit.....	3-20
3-23	Series Connection (Master/Slave) of two BOP Power Supplies, with Remote Error Sensing at the Common Load.....	3-22
3-24	Circuit Breaker Control Circuit, Simplified Diagram.	3-24
3-25	Parallel Connection (Master/Slave) of Two BOP Power Supplies with Remote Error Sensing at the Common Load.....	3-25
3-26	Alternative Parallel Connection (Master/Slave) for Greater Precision and Stability of Two or More BOP Power Supplies	3-26
3-27	Indicator Light and Flag Logic.....	3-27
3-28	Simplified Schematic Diagram, BOP 5-20DL, BOP 5-30DL	3-29
3-29	PC 15/PC 12 Rear Programming Connector Interconnections	3-31
4-1	Location of Internal Calibration Controls	4-2
4-2	Cover Removal and Internal Component Locations	4-6

LIST OF TABLES

TABLE	TITLE	PAGE
1-1	General Specifications	1-2
1-2	Output Impedance	1-4
1-3	Static Specifications: Output Effects, Offsets, And Reference Specifications	1-5
1-4	Dynamic Specifications	1-6
1-5	Dynamic Specifications, in Current Mode for 2mH Inductive Load	1-6
1-6	Rear Programming Connector Terminal Functions	1-8
1-7	Current Loop Bandwidth Reduction by Adding Compensation Capacitor to Rear Programming Connector (Resistive Load)	1-10
1-8	Equipment Supplied	1-13
1-9	Accessories - Not Supplied	1-13
1-10	Safety Symbols	1-13
2-1	BOP Front Panel Terminations and Controls	2-1
2-2	BOP Rear Panel Terminations and Controls	2-3
2-3	Chassis Slide Mounting Holes	2-6
4-1	Internal Calibration Controls	4-1



FIGURE 1-1. BOP 5-20DL, BOP 5-30DL POWER SUPPLY

SECTION 1 - INTRODUCTION

1.1 SCOPE OF MANUAL.

This manual contains instructions for BOP 5-20DL and BOP 5-30DL Operational Power Supplies manufactured by Kepco, Inc., Flushing, New York, U.S.A. The L suffix indicates that the unit is optimized to drive large inductive loads in a stable manner.

Note that throughout this manual E_O represents the rated output voltage, 5V, and I_O represents the rated output current, either 20A for BOP 5-20DL or 30A. for BOP 5-30DL

1.2 GENERAL DESCRIPTION.

Kepco Series BOP Bipolar Power Supplies are fully dissipative, linear stabilizers for laboratory and systems applications. The BOP is an all solid-state design, featuring IC operational amplifiers in the control circuit section and silicon power transistors mounted on special fan-cooled heat sinks in the complementary power stage.

Remote digital control of the BOP is possible using one of two optional digital interface cards (see Table 1-9). BIT 4886 allows communication via RS 232 or GPIB protocols, BIT 802E allows communication via web pages using a browser. IVI-COM, LabView and LabWindows Drivers are available for both cards. An EPICS driver is available for the BIT 802E.

The BOP has two bipolar control channels (voltage or current mode), selectable and individually controllable either from their front panel controls, or by remote signals. Each of the principal control channels is protected by bipolar limit circuits. In these limit circuits the positive and negative current or voltage limit points can be manually set or remotely programmed simultaneously or individually. Automatic crossover between each principal control channel and its associated limit channel is provided.

All control and limit channels are connected to the complementary output stage via an EXCLUSIVE OR gate, so that only one channel is in control of the BOP output at any one time. The BOP output can be programmed over its full output range by a ± 10 volt signal applied to either one of the inputs to the voltage or the current channel. The limit control channels can be controlled either locally through the front panel trim pots or remotely by a 0 to +10 volt signal applied to their respective inputs: the lower value (either local or remote) will be active. Two uncommitted preamplifiers, with both inverting and non-inverting inputs available at the Rear Programming Connector, can scale any programming source to the required control levels. Zero adjustments for both preamplifiers are provided.

The BOP is a fast programmable power supply. The dynamic specifications, given in Table 1-3, are valid for resistive loads, while those shown in Table 1-5 are for a benchmark inductive load of 2mH, with the BOP operating in current mode.

1.3 ELECTRICAL SPECIFICATIONS, GENERAL

See Table 1-1 for general specifications

TABLE 1-1. GENERAL SPECIFICATIONS

SPECIFICATION		RATING/DESCRIPTION	CONDITION/COMMENT
A-C Input Voltage	Nominal	104V / 115V / 208V / 230V	Internal setting, see Figure 2-3
	Range	95-113V / 105-125V / 190-226V / 210-250V	
	Brown-out	93V / 103V / 186V / 206V	
	Frequency	50 / 60 Hz	nominal, ± 3 Hz range
A-C Input Current	BOP 5-20DL	4.7A	Nominal output power, sourcing, @115V a-c/ 60Hz
	BOP 5-30DL	5.2A	
Inrush input current		50A peak (max)	115V a-c/60Hz
Active Input power	BOP 5-20DL	460W	Nominal output power, sourcing, @115V a-c/ 60Hz
	BOP 5-30DL	570W	
Power Factor		0.84	Nominal output power, sourcing, @115V a-c/ 60Hz
Input Leakage Current (through earth-ground connection)		0.1mA rms	115V/ 60Hz
Insulation Coordination	Input	Installation Cat. 2, Overvoltage Cat. 2, Pollution Deg. 2	For TN or TT power systems
	Output	Installation Cat. 2, Overvoltage Cat. 2, Pollution Deg. 2	Max. 500V between COMMON output terminal and chassis
Topology		Linear Half bridge (AB Class)	
Mode of operation		Voltage Mode with Current Limit and Voltage Limit OR Current Mode with Voltage Limit and Current Limit	Selectable by a) front panel switch, b) control signal applied to the rear programming connector (see Table 1-6) or c) BIT Card installed (see PAR. 1.4.16).
DC Transfer Factor (Closed Loop Gain)	Voltage in Voltage mode	-0.5V/V $\pm 0.2\%$, with default preamplifier	For the default "inverting" configuration.
	Current in Current mode BOP 5-20DL	-2A/V $\pm 0.2\%$ with default preamplifier	See Figures 3-8 and 3-17 for "non-inverting" configurations in voltage/current mode. Preamplifier's amplification factor can be changed by modifying connections and adding resistors at rear programming connector. DC Transfer Factor is not adjustable for voltage in voltage mode nor for voltage and current limits. The DC Transfer Factor in current mode is adjustable $\pm 5\%$ by A3R316 (see PAR. 4.2.8).
	Current in Current mode BOP 5-30DL	-3A/V $\pm 0.2\%$ with default preamplifier	
	Voltage in Voltage limit	+0.55V/V $\pm 2\%$ for positive limit -0.55V/V $\pm 2\%$ for negative limit	
	Current in Current limit BOP 5-20DL	+2.2A/V $\pm 2\%$ for positive limit -2.2A/V $\pm 2\%$ for negative limit	
	Current in Current limit BOP 5-30DL	+3.3A/V $\pm 2\%$ for positive limit -3.3A/V $\pm 2\%$ for negative limit	

TABLE 1-1. GENERAL SPECIFICATIONS

SPECIFICATION		RATING/DESCRIPTION	CONDITION/COMMENT
Output Power	Source or Sink BOP 5-20DL	100W (d-c or peak)	For full operating temperature range and full a-c input voltage range. Internal dissipative sink. Fully operation in all four voltage-current quadrants.
	Source or Sink BOP 5-30DL	150W (d-c or peak)	
Source/Sink Output Range- Main channel	Voltage	Remote: -5V to +5V Local: -5.25V to +5.25V	For remote, use programming signal in +10V to -10V range (with the default preamplifier). See "DC Transfer Factor" on page 1- 2 for tolerances
	Current BOP 5-20DL	Remote: -20A to +20A Local: -21A to +21A	
	Current BOP 5-30DL	Remote: -30A to +30A Local: -31.5A to +31.5A	
Source/Sink Output Range- Limit channel	Voltage	+0.05V to +5.5V, for positive limit -0.05V to -5.5V, for negative limit	Remote or local. For remote programming of all limits, use programming signal in 0V to +10V range. ±2% Full scale tolerance
	Current BOP 5-20DL	+0.1A to +22A, for positive limit -0.1A to -22A, for negative limit	
	Current BOP 5-30DL	+0.1A to +33A, for positive limit -0.1A to -33A, for negative limit	
Static Specifications		See Table 1-3	
Output Impedance		See Table 1-2	
Analog Readback Accuracy	Voltage	0.05% of rated readback voltage	Zero to ±10V for zero to ± Rated output voltage or current. Available at rear programming connector (see Table 1-6).
	Current	0.1% of rated readback voltage	
Front Panel Monitoring for Voltage and Current	Type	3 and ½ digit DPMs	
	Resolution	0.1V for voltage, 0.1A for current	
	Accuracy BOP 5-20DL	0.2% of rated output, 10mV for voltage and 40mA for current	
	Accuracy BOP 5-30DL	0.2% of rated output, 10mV for voltage and 60mA for current	
Output Flags	Voltage Mode	TTL signal, logic 0 for voltage mode	Not isolated, referenced to output common (signal-ground). Available at rear programming connector (see Table 1-6).
	Current Mode	TTL signal, logic 0 for current mode	
	Voltage Limit	TTL signal, logic 0 for voltage limit	
	Current Limit	TTL signal, logic 0 for current limit	
	Remote	TTL signal, logic 0 for remote, logic 1 for local	
	Output On-Off	Optocoupler (open collector transistor)	Isolated flag

TABLE 1-1. GENERAL SPECIFICATIONS

SPECIFICATION		RATING/DESCRIPTION	CONDITION/COMMENT
Output On-Off control	Type	Optocoupler	Isolated control. On-off controlling logic established by signal applied to rear programming connector pin 21 (see Table 1-6). NOTE: If an optional BIT card (PAR. 1.4.16) is in use, the on-off feature is through the digital control.
	Output Voltage for Off Status	0V \pm 0.01% E _{Onom}	Adjustable (see PAR. 4.2.5).
	Output Current for Off Status	0A \pm 0.01% I _{Onom}	Adjustable (see PAR. 4.2.5).
Dynamic Specifications		See Tables 1-4, 1-5 and 1-7	
Calibration		See Table 4-1	Using reduced range 10-turn trim pots for some signals
Kelvin Connection (remote error sensing)		max. 0.25V/ wire	Without protection or limiting circuit.
Protection	Input overcurrent	Always trips input circuit breaker	
	Heatsink overtemperature	Always trips input circuit breaker	
	Input power loss	Jumper on rear programming connector offers choice whether or not to trip input circuit breaker	
Series or Parallel connection of identical units	Type of connection	Master-Slave	Contact factory for more than 3-units being connected in series or in parallel
	Implementation	Using external wiring, no standard cables provided	
Front Panel		See Figure 2-1 and Table 2-1	
Rear Panel		See Figure 2-2 and Table 1-6	Provides access to rear programming connector and Output ON-OFF port
Output Isolation Voltage	d-c or p-p	500V	Output to chassis ground
	d-c leakage current	0.05mA @ 500V	
Temperature:	Operating	0°C to +55°C	
	Storage	-40°C to +85°C.	
Humidity		0 to 95%RH	Non-condensing
Cooling		Internal a-c fan	Intake from the top & sides, exhaust to the rear
Shock		20g/ 11ms/ 50% half sine	Non-operating
Vibration	5-10Hz	10mm, double amplitude	Non-operating
	10-55Hz	2g	
Altitude		Sea level to 10,000ft	For operating temperature range
Dimensions		See Figure 1-5	

TABLE 1-1. GENERAL SPECIFICATIONS

SPECIFICATION		RATING/DESCRIPTION	CONDITION/COMMENT
Weight	BOP 5-20DL	48 lbs	Unpacked
	BOP 5-30DL	52 lbs	

TABLE 1-2. OUTPUT IMPEDANCE

MODEL	OUTPUT IMPEDANCE			
	VOLTAGE MODE		CURRENT MODE	
	SERIES R	SERIES L	SHUNT R	SHUNT C
BOP 5-20DL	10 $\mu\Omega$	4 μ H	5k Ω	10 μ F
BOP 5-30DL	10 $\mu\Omega$	4 μ H	5k Ω	15 μ F

1.3.1 STATIC SPECIFICATIONS

The static specifications are listed in Table 1-3. The BOP output effects, in response to the tabulated variations in the Influence Quantities, are given in Table 1-3 for the built-in input and feedback resistor values of the voltage and current channel preamplifiers.

TABLE 1-3. STATIC SPECIFICATIONS: OUTPUT EFFECTS, OFFSETS, AND REFERENCE SPECIFICATIONS

INFLUENCE QUANTITY	OUTPUT EFFECTS ⁽¹⁾				PREAMPLIFIER ⁽⁴⁾ OFFSETS		REFERENCE $\pm 10V$
	VOLTAGE MODE		CURRENT MODE		ΔE_{in}	ΔI_{in}	
	TYPICAL	MAXIMUM	TYPICAL	MAXIMUM			
SOURCE VOLTAGE (min-max):	0.0005%	0.001%	0.002%	0.005%	<5 μ V	<1nA	<0.0005%
LOAD (no load-full load):	0.002%	0.004%	0.5mA	1mA	—	—	<0.0005%
TIME (8-hour drift):	0.005%	0.01%	0.01%	0.02%	<20 μ V	<1nA	0.005%
TEMPERATURE (per °C):	0.005%	0.01%	0.01%	0.02%	<20 μ V	<1nA	0.005%
RIPPLE AND NOISE: ⁽²⁾	rms	1mV	3mV	0.01%	0.03%	—	—
	p-p ⁽³⁾	10mV	30mV	0.1%	0.3%	—	—

(1) Output effects, expressed as a percentage, are referred to the maximum rated output voltage or current.

(2) Measured with the common terminal grounded so that the common mode current does not flow through the load.

(3) Peak-to-peak ripple is measured over a 20 Hz to 10 MHz bandwidth.

(4) To permit calculating of the effect of non-standard control current (less than the normal 1 mA) of non-standard gain ratios.

The tabulated Pre-amplifier Offset values (see Table 1-3) may be used to calculate the BOP output effects if the BOP voltage or current channel is remotely programmed and different values for the feedback resistors (R_f) and the input resistors (R_i) are used. In this case, the tabulated Pre-amplifier offsets and the values of the feedback and input resistors are combined in an "Error Equation," which represents the "Worst Case" output effect for the application at hand:

NOTE: Variations in the value of the feedback and input resistors are considered secondary effects in the Error Equation.

$$\text{VOLTAGE MODE: } \Delta E_o = G_V [\pm \Delta E_{i_o} (1 + R_f/R_i) + \Delta I_{i_o} R_f \pm \Delta E_{ref}]$$

$$\text{CURRENT MODE: } \Delta I_o = G_I [\pm \Delta E_{i_o} (1 + R_f/R_i) + \Delta I_{i_o} R_f \pm \Delta E_{ref}]$$

Where:

- ΔI_o = Total Output Current Change.
- ΔG_V = Closed Loop Gain, Voltage Mode, (see Table 1-1).
- G_I = Closed Loop Gain, Current Mode, (see Table 1-1).
- ΔE_o = Total Output Voltage Change.
- ΔE_{ref} = Change in the Voltage Reference.
- ΔE_{i_o} = Change in Offset Voltage.
- ΔI_{i_o} = Change in Offset Current.
- R_f = External Feedback Resistor.
- R_i = External Input Resistor.

1.3.2 DYNAMIC SPECIFICATIONS

Dynamic specifications are listed in Table 1-5 for a nominal resistive load, and in Table 1-5 for a 2mH inductive load (current mode). The typical dynamic responses of the BOP output are tabulated in both the time domain (Output response to a step program) and in the frequency domain (bandwidth) for large and small signals.

TABLE 1-4. DYNAMIC SPECIFICATIONS

MODEL	3dB SMALL SIGNAL BANDWIDTH (1) (KHz)		RISE AND FALL TIME 10-90% (2) (3) (μS)		LARGE SIGNAL FREQUENCY RESPONSE (2) (KHz)		SLEW RATE (2)		RECOVERY AT STEP LOAD (3) (μS)	
	Voltage	Current	Voltage	Current	Voltage	Current	Voltage	Current	Voltage	Current
BOP 5-20DL	10	4.0	40	90	11	3.9	0.2V/μS	0.36A/μS	40	100
BOP 5-30DL	10	3.6	40	110	11	3.5	0.2V/μS	0.22A/μS	40	130

NOTES:

- (1) 10% scale and load.
- (2) 100% scale and load
- (3) 10% to 90% timing for 100% step load

TABLE 1-5. DYNAMIC SPECIFICATIONS, IN CURRENT MODE FOR 2mH INDUCTIVE LOAD

MODEL	3dB BANDWIDTH (Hz)	RISE & FALL TIME 10%-90% (msec)
BOP 5-20DL	55	6.4
BOP 5-30DL	32	10.9

1.4 MISCELLANEOUS FEATURES

1.4.1 OUTPUT RANGE

The BOP can be locally (front panel) adjusted, or remotely programmed, from (-)100% to (+)100% of its specified d-c voltage and current range. The Class AB bipolar output stage permits operation as either a *source* or a *sink*. (See Figure 1-2).

NOTE: The BOP is operating as a *source* if the direction of its output voltage is the same as the direction of its output current. The BOP is operating as a *sink* if the direction of its output voltage is opposite that of its output current. An illustrative case is shown in Figure. 1-3, where the BOP is programmed to deliver a sine wave output and where the load produces a phase shift between the output voltage and current.

1.4.2 REAR PROGRAMMING FEATURES

The external Rear Programming Connector (See Table 2-2, Items 22 and 23 and Figure 3.2.1), is a 50-pin edge connector, providing access to all circuit features. The BOP is delivered with one (1) PC 15 connector, which is prewired with jumpers for local (front-panel) operation. Spare connectors may be purchased from Kepco under the model number PC 12 for the unwired connector and PC 15 for a connector prewired for local operation. The functions of the Rear Programming Connector terminals are listed below in Table 1-6.

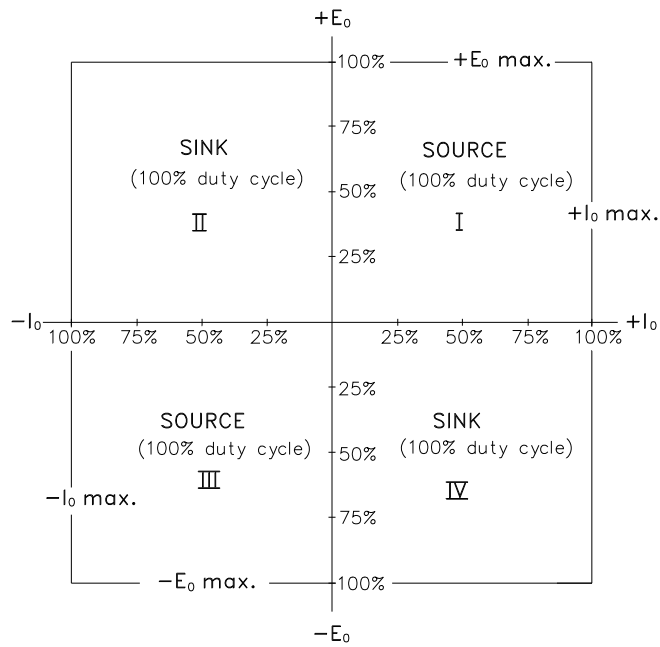

3043872

FIGURE 1-2. BOP OUTPUT CHARACTERISTIC

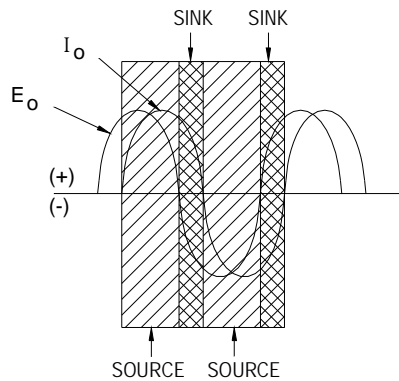

3043440

FIGURE 1-3. BOP OUTPUT WAVEFORM WITH PHASE SHIFT

TABLE 1-6. REAR PROGRAMMING CONNECTOR TERMINAL FUNCTIONS

TERMINAL (Figure 3.2.1)	FUNCTION	DESCRIPTION
1	Current Limit Reference	Refer to PAR. 3.3.2
3	Voltage Limit Reference	Refer to PAR. 3.3.4
15 13 2 4	<p>Preamp "B"</p> 	Refer to PAR. 3.5 for example.
11 9 5 7	<p>Preamp "A"</p> 	Refer to PAR. 3.4.1 for example.
6	+E _O Limit Input	Refer to PAR. 3.3.4
8	+I _O Limit Input	Refer to PAR. 3.3.2
32	-E _O Limit Input	Refer to PAR. 3.3.4
34	-I _O Limit Input	Refer to PAR. 3.3.2
10	Current Monitoring	Analog output voltage (0 to ±10V, 1 mA max) proportional to the prevailing BOP output current for remote metering or monitoring.
20	Voltage Monitoring	Analog output voltage (0 to ±10V, 1 mA max) proportional to the prevailing BOP output voltage.
12, 14	Voltage Mode Compensating Terminals	Refer to PAR. 1.4.4
16, 18	Current Mode Compensating Terminals	Refer to PAR. 1.4.4
17	Voltage Comparison Amp Input	Analog input voltage of 0 to ±10V will produce 0 to ± full output voltage with unit set in voltage mode.
19	Current Comparison Amp Input	Analog input voltage of 0 to ±10V will produce 0 to ± full output current with unit set in current mode.
21	On-off Controlling Logic	<p>Establishes whether TTL "1" or "0" applied to pin 50, referenced to pin 48 turns the output on or off.</p> <p>No signal (default) or "1" (15V CMOS): "0" = ON, "1" = OFF</p> <p>"0" or short to pin 23: "1" = ON, "0" = OFF</p> <p>If no signal is applied to pin 50, pin 21 can be used as a non-isolated on-off control:</p> <p>no signal or "1" (15V CMOS) = output ON</p> <p>Short to pin 23 or "0": = output OFF</p>
22	-10V Reference Voltage 4mA Max	Refer to PAR. 3.4.1 for examples.
28	+10V Reference Voltage 4mA Max	Refer to PAR. 3.4.1 for examples.
23, 25, 27, 29, 31, 33	Sensing Common	
24	Circuit Breaker Control	Refer to PAR, 3.6.2
26, 36	Turn-off Signal Output	Refer to PAR, 3.6.2

TABLE 1-6. REAR PROGRAMMING CONNECTOR TERMINAL FUNCTIONS (CONTINUED)

TERMINAL (Figure 3.2.1)	FUNCTION	DESCRIPTION
30	Voltage Mode/Current Mode control	Used to set either voltage mode or current mode (disables front panel MODE switch). For use only if a BIT card is not installed. Remote mode (pin 35) must be active (TTL "0") to enable pin 30. Voltage mode = open or TTL "1" Current mode = short (referenced to sensing common, pin 23) or TTL "0"
35	Local/Remote control	Used to set either local or remote mode For use only if a BIT card is not installed. Pin 35 must be set to Remote for pin 30 to be active. Local mode = open or TTL "1" Remote mode = short (referenced to sensing common, pin 23) or TTL "0"
37	+5V	Built-in TTL Logic supply, 5V @ 40mA max.
38	I _O Limit Flag	Refer to PAR. 3.7
39	E _O Limit Flag	Refer to PAR. 3.7
40	E _O Mode Flag	Refer to PAR. 3.7
42	I _O Mode Flag	Refer to PAR. 3.7
41	Non-isolated Turn-off Signal Input	Refer to PAR, 3.6.2
43, 44, 45	Not Used.	
46	/ON-OFF_FLAG	Flags whether output set to ON or OFF. This isolated flag signal is the open collector of an optocoupler-transistor, with the emitter connected to pin 48. Optocoupler transistor is saturated when the output is ON (enabled). Current through the transistor should not exceed 1.6mA and supply voltage should not exceed 24V. OFF level: determined by (Vext) - (Rext) (Icoff) where: Vext = External positive voltage Rext = Vext/1.6mA (External current-limiting resistor). Icoff = 0.0001mA (optocoupler transistor maximum dark current) The flag's rise time for either voltage mode with no load, or current mode with short circuit, is within 150μS max. ON level: +0.4V max. for 1.6mA current. The flag's fall time for either voltage mode with no load, or current mode with short circuit, is within 150μS max.
47, 49	Optically Isolated Turn-off Signal Input	Refer to PAR, 3.6.2
48	ISO_GND	Return for ON-OFF_CTRL and for /ON_OFF_FLAG signals.
50	ON-OFF_CTRL	Optically isolated signal that controls output to be either ON (enabled) or OFF (disabled). The logic of the control is established by pin 21. TTL "0" or no control = ON (default) TTL "1" = OFF ON control (default): 0V to 0.4V or no connection (open circuit) at pin 50, referenced to pin 48. Turns ON within 100μS max (between 10% point of controlling signal and a) 10% point of output voltage for voltage mode with no load or b) 10% point of output current for current mode with short circuit). OFF control (default): 3.5V to 24V d-c at pin 50 referenced to pin 48; input current is 1mA ±0.3mA. Turns OFF within 100μS max (between 90% point of controlling signal and a) 90% point of output voltage for voltage mode with no load or b) 90% point of output current for current mode with short circuit). If the BOP has a BIT card installed and active, the ON-OFF_CTRL and /ON-OFF_FLAG (pin 46) are disabled to allow the BIT card to control output on-off and monitor output on-off status.

1.4.3 REMOTE OUTPUT ON-OFF FEATURE

The output of the unit can be turned ON (enabled) or turned OFF (disabled) from the rear panel isolated ON-OFF signal applied to pin 50 referenced to pin 48 of the rear programming connector or by a non-isolated ON-OFF signal applied to pin 21 referenced to pin 23 (see Table 1-6). Output off signal value is adjustable (see PAR. 4.2.5):

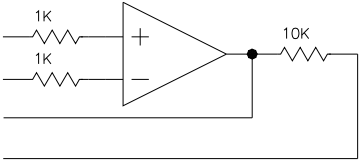
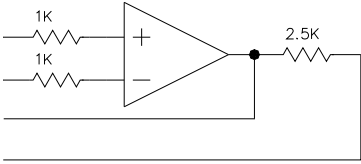
- to $0V \pm 0.001V$ by E_O - OFF ZERO potentiometer in voltage mode
- to $0A \pm 0.001A$ by I_O - OFF ZERO potentiometer in current mode.

1.4.4 LOAD REACTANCE

1.4.4.1 DRIVING AN INDUCTIVE LOAD IN CURRENT MODE

The BOP 5-20DL or BOP 5-30DL power supply is optimized for driving large inductor loads (L suffix). Factory test were performed with loads up to 1H, however higher values are possible.



CAUTION: When driving heavy inductive loads with high currents, it is possible for the BOP and the load to be damaged by an A-C input power loss which prevents the load's stored energy from being dissipated inside the BOP. To avoid possible damage observe the following:

- Use UPS to supply the BOP.
- Set BOP output current and/or voltage to zero and turn off the BOP after the output current actually reaches a zero value.
- Use properly rated (voltage and current) bipolar transorbs or a properly rated bipolar crowbar element connected directly at the output of the BOP. An alternative is a Normally-Closed Contactor connected across the output of the BOP. These options may also be combined.

When driving an inductive load, if the system becomes unstable at the crossover between voltage limit mode and current mode, the power supply can be further optimized by reducing the current loop bandwidth. This can be accomplished by connecting a ceramic capacitor across pins 16 and 18 of the Rear Programming Connector (see Figure 3.2.1 and Table 1-6). Refer to Table 1-7 for bandwidths resulting from typical capacitor values.

TABLE 1-7. CURRENT LOOP BANDWIDTH REDUCTION BY ADDING COMPENSATION CAPACITOR TO REAR PROGRAMMING CONNECTOR (RESISTIVE LOAD)

	Ceramic Capacitor Value connected across Rear Programming Connector pins 16 and 18						
	0.01 μ F	0.022 μ F	0.047 μ F	0.1 μ F	0.22 μ F	0.47 μ F	1.0 μ F
3dB Bandwidth	2.6KHz	1.8KHz	0.9KHz	0.5KHz	0.25KHz	0.12KHz	0.06KHz

1.4.4.2 DRIVING A CAPACITIVE LOAD IN VOLTAGE MODE

When driving a capacitive load in voltage mode, the system can become unstable. Install an external ceramic capacitor rated for 50V across pins 12 and 14 of the rear programming connector for stable operation. The value of the capacitor is correlated to the load's capacitance. A value in the range of 0.0047 μ F to 0.47 μ F is recommended.

1.4.5 REMOTE TURN-OFF

Remote turn-off of the BOP, equivalent to tripping the front panel ON/OFF circuit breaker to OFF, can be accomplished by a contact closure, or by an optically isolated signal (see PAR. 3.6.2).

1.4.6 CIRCUIT BREAKER SHUTDOWN PREVENTION (AT POWER LOSS) CIRCUIT

See PAR. 3.6.2.

1.4.7 REFERENCES

Two reference/bias sources ($\pm 10V$ at 4 mA max.) are provided for control and biasing purposes. These reference sources are available at the rear programming connector (with reference to the "COMMON" terminal). Their specifications are tabulated In Table 1-3.

1.4.8 SERIES OR PARALLEL OPERATION

See PAR. 3.6

1.4.9 VOLTAGE CONTROL CHANNEL

The Bipolar Voltage Amplifier, with a fixed gain (See Table 1-1 for gain value) is connected via the MODE switch to the Voltage Preamplifier (see Figure 3-1). If the VOLTAGE CONTROL switch is on, the BOP output voltage can be locally controlled by means of the (front panel) (\pm) 10 volts bias source, from (-) 100% (through zero) to (+) 100% of the rated value. The Voltage Preamplifier is provided with a Zero control and all its terminals are available at the Rear Programming Connector for remote control of the output voltage. Control methods are described in PAR. 3.4.

1.4.10 MODE SWITCH

The BOP is equipped with a front panel-mounted MODE switch, which selects bipolar voltage or bipolar current control. See paragraph 1.4.14 for remote MODE control.

1.4.11 CURRENT CONTROL CHANNEL

The Bipolar Current Amplifier, with a fixed gain (See Table 1-2 for gain value) is connected via the MODE switch to the Current Preamplifier (see Figure 3-3). If the CURRENT CONTROL switch is on, the BOP output current can be locally controlled by means of the (front panel) (\pm) 10 volts bias source, from (-) 100% (through zero) to (+) 100% of the rated value. The Current Preamplifier is provided with a Zero control and all its terminals are available at the Rear Programming Connector for remote control of the output current. Control methods are described in PAR. 3.5.

1.4.12 BOUNDING

The BOP has four output voltage/current limiting circuits (-) E_o Limit, (+) E_o Limit, (-) I_o Limit and (+) I_o Limit for overvoltage/overcurrent protection in either operating mode (refer to Figures 3-4 and 3-2). All limiting circuits can be screwdriver adjusted by means of four front panel controls. In addition, all four limits can be remotely controlled by means of 0 to 10 volt d-c control voltages. The four limits may be programmed independently, or the (\pm) voltage and (\pm) current limits can be controlled in pairs. The adjustable/programmable limit controls are backed-up by front panel-adjustable limit circuits which define the four boundaries [\pm] E_o max. and [\pm] I_o max.]

of the BOP, and provide protection against accidental over-programming of the adjustable limits.

The four boundary quantities, $(\pm) E_o$ max. and $(\pm) I_o$ max. as applied to the Limit Channel, are actually about 10% greater than the rated values E_o max. and I_o max. for each BOP model. Similarly, the quantities E_o Zero and I_o Zero are not really zero, but are approximately 1% of the rated E_o max. and approximately 0.5% of I_o max. values. (See Figure 1-4.)

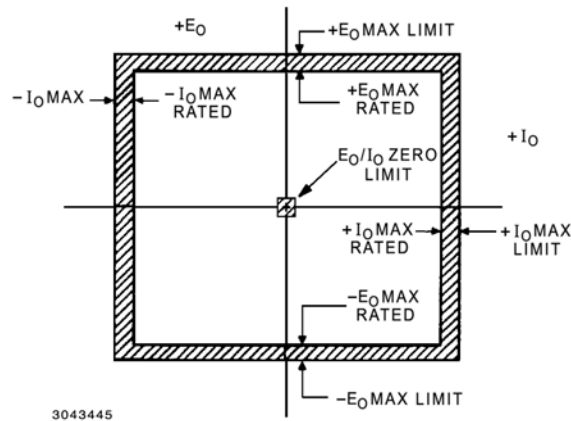

FIGURE 1-4. BOUNDARIES AND LIMITS

1.4.13 MODE LIGHTS

Four (4) front panel (LED type) indicator lamps monitor the prevailing operating mode of the BOP. For each operating condition (Voltage Mode, Current Mode, $\pm E_o$ Limit, $\pm I_o$ Limit) the corresponding indicator lamp energizes. Simultaneous TTL flags are available on the Rear Programming Connector. See PAR. 3.7

1.4.14 REMOTE (W/ DIG ON) / OUT ON (W/ DIG OFF) LED

This is a dual function indicator, depending on whether a digital BIT card is active. If a BIT card is controlling the output (DIG ON = digital card active), the indicator functions as a REMOTE digital control indicator. If a BIT card is not active (DIG OFF), the indicator functions as an OUTPUT ON indicator and is lit for output on (enabled) and off for output off (disabled).

1.4.15 STANDARDS

BOP models are designed and tested in accordance with NEMA Standard for Stabilized Power Supplies, d-c output, Publication No. PY-1.1972.

1.4.16 OPTIONAL DIGITAL REMOTE CONTROL (BIT CARDS)

Digital Remote Control is available through optional BIT cards. Models with a -4886 suffix include a factory installed BIT 4886 card that allows remote control via GPIB or RS 232 protocols using SCPI commands. Models with a -802E suffix include a factory-installed BIT 802E card that allows remote control via a LAN using using SCPI commands. Use of these cards is documented in the associated BIT card manual that can be downloaded from the Kepco web site at:

www.kepcopower.com/support/opmanls.htm#bit

1.5 MECHANICAL SPECIFICATIONS

See Mechanical Outline Drawing, Figure 1-5 for dimensions and finish. Two (2) digital meters, monitoring the \pm d-c output voltage and the \pm d-c output current, are provided. The full rack BOP 5-20DL model is 48lbs. (22 kg) unpacked.

1.6 EQUIPMENT SUPPLIED

Equipment supplied is listed in Table 1-8.

4

TABLE 1-8. EQUIPMENT SUPPLIED

ITEM	PART NUMBER	QUANTITY
Rear Programming Connector (Local Control) - 50-terminal printed circuit connector for all rear programming connections and flag-signal outputs, wired for local (front panel) control of the BOP output.	PC 15	1
Power Cord, IEC connection to standard 115 VAC (USA),	118-0557	1
Mounting Flanges - for installation of the BOP into a standard (19 inch) equipment rack Right Left.	128-0927	1
	128-0926	1
Local Sensing Links at front panel	172-0122	2

1.7 ACCESSORIES

Accessories (not supplied) are listed in Table 1-9.

TABLE 1-9. ACCESSORIES - NOT SUPPLIED



ITEM	FUNCTION	KEPCO PART NUMBER
Rear Programming Connector, Unwired	50-terminal printed circuit connector, unwired, for access to all rear programming connections and flag-signal outputs.	PC 12
Slides	Ease of access to adjustments through top cover	110 QD (Jonathan)
BIT 4886 Interface Card	Allows remote programming of BOP via GPIB or RS 232 interface using IEEE 488 and SCPI commands and queries.	BIT 4886
BIT 802E Interface Card	Allows remote programming of BOP via Ethernet /LAN using web pages.	BIT 802E

1.8 SAFETY

Service must be referred to authorized personnel. Using the power supply in a manner not specified by Kepco. Inc. may impair the protection provided by the power supply. Observe all

safety precautions noted throughout this manual. Table 1-10 lists symbols used on the power supply or in this manual where applicable.

TABLE 1-10. SAFETY SYMBOLS

SYMBOL	Meaning
	WARNING: RISK OF ELECTRIC SHOCK.
	CAUTION: REFER TO REFERENCED PROCEDURE.
WARNING	INDICATES THE POSSIBILITY OF BODILY INJURY OR DEATH.
CAUTION	INDICATES THE POSSIBILITY OF EQUIPMENT DAMAGE.

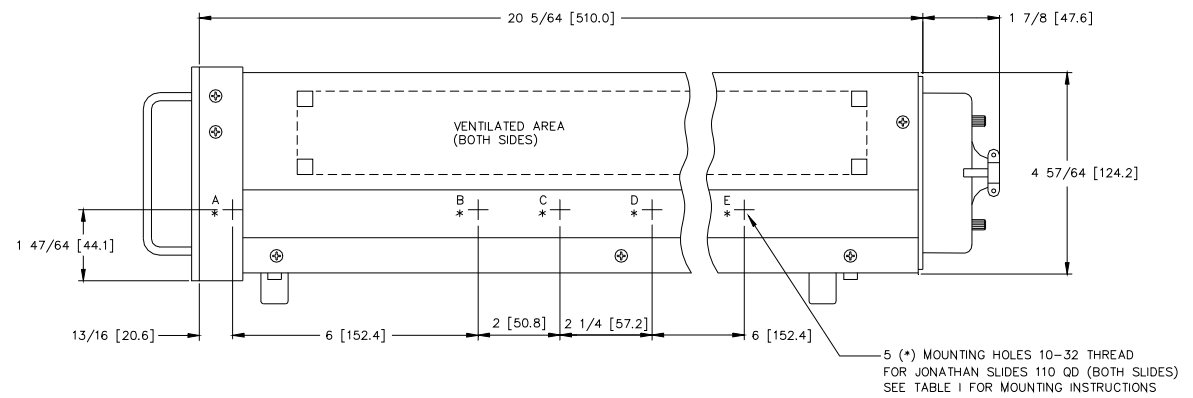
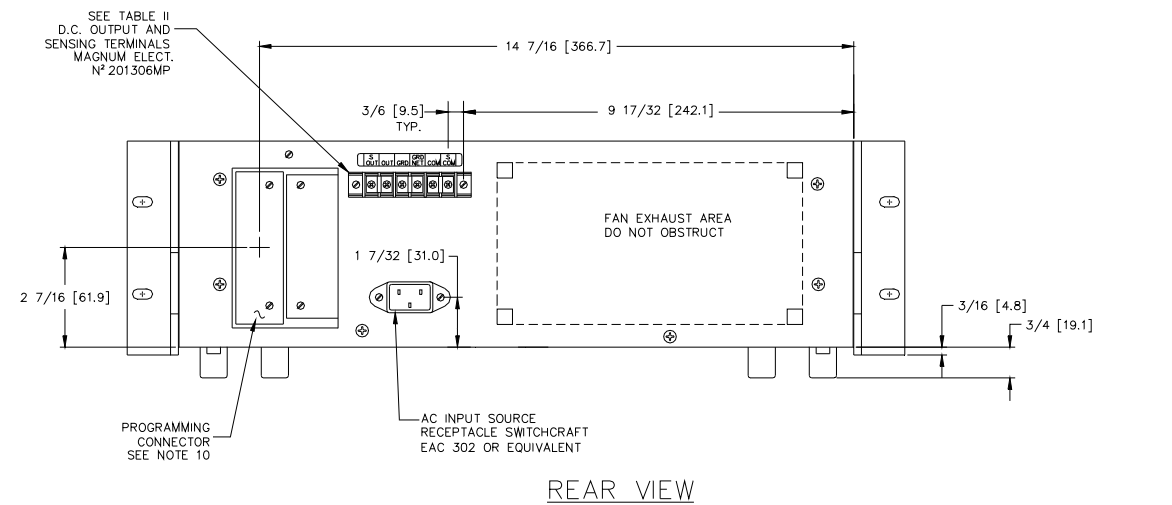
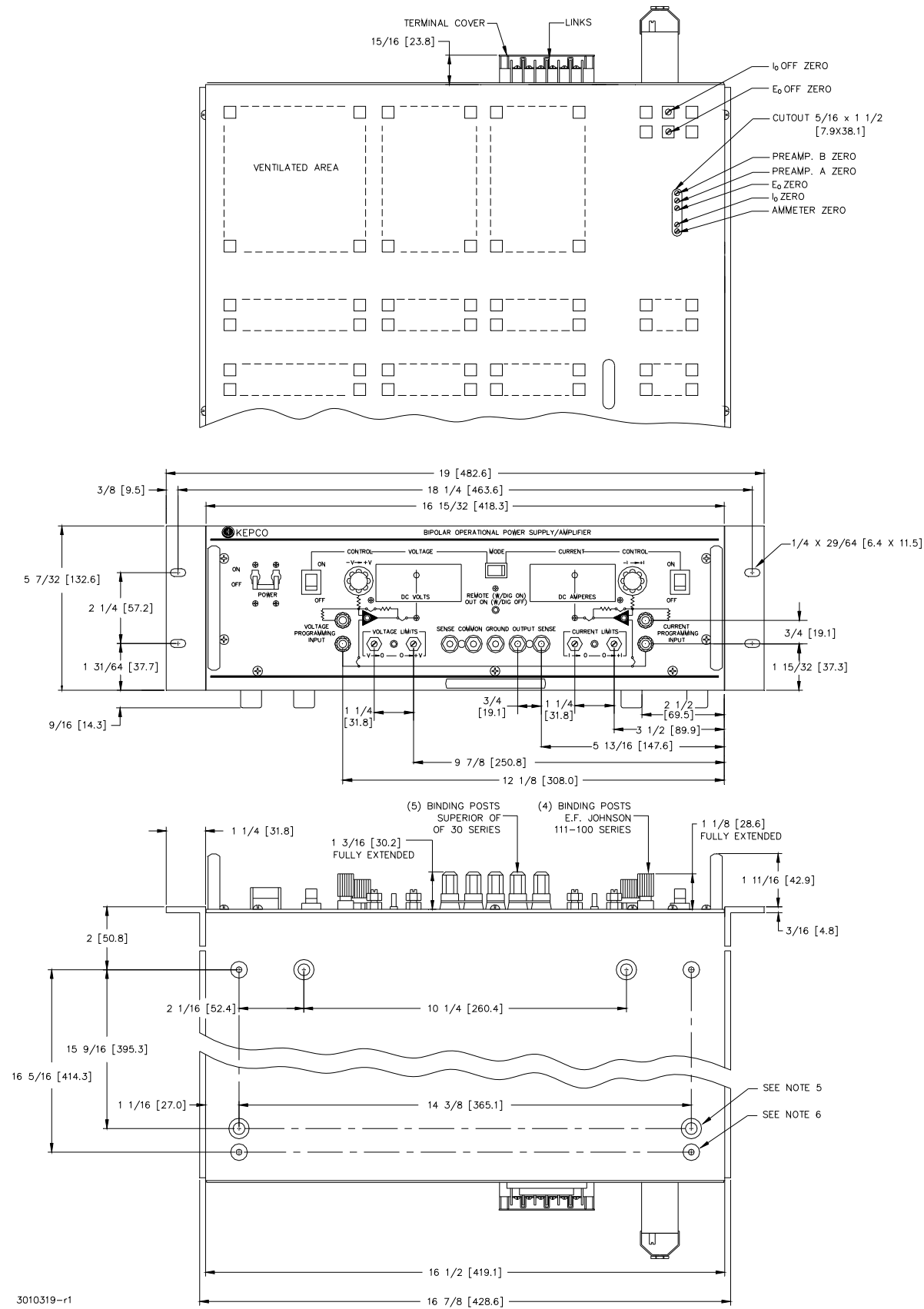

- NOTES:
- THIS DRAWING IS USED FOR THE BOP FULL RACK
 - MATERIAL:
 - CHASSIS AND BACK PLATE: No. 14 GA CRS
 - FRONT PANEL: 1/8 THICK ALUMINUM
 - COVER: No. 16 GA CRS
 - FINISH:
 - CHASSIS AND BACK PLATE: CADMIUM PLATE WITH CHROMATE WASH
 - FRONT PANEL: LIGHT GRAY PER FEDERAL STD 595 COLOR No. 26440
 - COVER: CHARCOAL GRAY VINYL TEXTURE
 - FIXED ANGLE BRACKETS AND CHASSIS SIDE SUPPORT BARS (BOTH SIDES), USED FOR RACK OR CABINET INSTALLATION CAN BE REMOVED FOR BENCH OPERATION
 - RACK OR CABINET MOUNTING: REMOVE (4) METAL FEET
 - (4) PLASTIC INSERTS FOR 1/4-20 THREAD CUTTING SCREWS 5/8 LONG (WITH 1/8 MOUNTING SURFACE THICKNESS)
 - IF INSTALLATION WITHOUT SLIDES IS DESIRED, THE UNIT MUST BE SUPPORTED BY A RIGID PLATFORM OR BY A FIXED BRACKET MOUNTED ON THE RACK
 - DIMENSIONS IN PARENTHESIS ARE IN MILLIMETERS
 - TOLERANCES:
 - BETWEEN MOUNTING HOLES $\pm 1/64$ [0.4]
 - ALL FRONT PANEL DIMENSIONS TO MIL-STD-189
 - ALL OTHER DIMENSIONS $\pm 1/32$ [.8] EXCEPT AS NOTED
 - PROGRAMMING CONNECTOR, PC-15 WITH DEFAULT WIRING (PC-12 REPRESENTS THE UN-WIRED CONNECTOR)

KEPCO P/N	SLIDE TYPE	MOUNTING TABLE I				
		A	B	C	D	E
108-0067	110 QD-20-2	X	X	NOT USED	X	●
108-0156	110 QD-22-2	X	NOT USED	X	NOT USED	X
108-0192	110 QD-24-2	X	NOT USED	X	NOT USED	●

● "E" HOLE HAS TO BE ADDED TO SLIDES BOTH SIDES 0.199 DIA. HOLE 16-1/4 FROM "A" HOLE

TABLE II D.C. OUTPUT AND SENSING TERMINALS	
1	OUTPUT SENSING
2	OUTPUT
3	GROUND
4	GROUND NETWORK
5	COMMON
6	COMMON SENSING

FIGURE 1-5. MECHANICAL OUTLINE DRAWING, BOP 5-20DL, BOP 5-30DL

SECTION 2 - INSTALLATION

2.1 UNPACKING AND INSPECTION.

This instrument has been thoroughly inspected and tested prior to packing and is ready for operation. After careful unpacking, inspect for shipping damage before attempting to operate. Perform the preliminary operational check as outlined in PAR. 2.13. If any indication of damage is found, file an immediate claim with the responsible transport service.

2.2 TERMINATIONS, CONTROLS AND INDICATORS

- a) Front Panel: Refer to Figure 2-1. See Table 2-1 for an explanation of terminations, controls and indicators.
- b) Rear Panel: Refer to Figure 2-2 and Table 2-2 for an explanation of terminations.

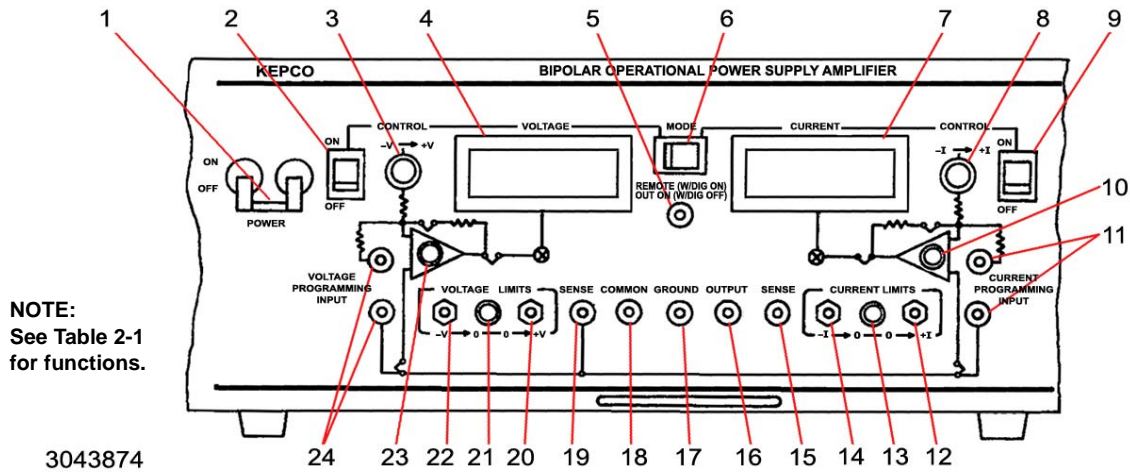

FIGURE 2-1. BOP TERMINATIONS AND CONTROLS, FRONT PANEL

TABLE 2-1. BOP FRONT PANEL TERMINATIONS AND CONTROLS

FIG. 2-1 INDEX NO.	NAME OF TERMINATION OR CONTROL	FUNCTION
FRONT		
1	A-C POWER circuit breaker	A-C circuit breaker/power switch.
2	VOLTAGE CONTROL switch	ON-OFF switch is set to ON to allow VOLTAGE control (3) to provide manual adjustment of the BOP d-c output voltage
3	VOLTAGE control	Provides manual adjustment of BOP d-c output voltage when VOLTAGE CONTROL switch set to ON.
4	VOLTAGE meter	E_o d-c digital output voltmeter

TABLE 2-1. BOP FRONT PANEL TERMINATIONS AND CONTROLS (CONTINUED)

FIG. 2-1 INDEX NO.	NAME OF TERMINATION OR CONTROL	FUNCTION
5	REMOTE (W/DIG ON) OUT ON (W/DIG OFF) indicator	Dual function LED indicator, function depends on whether a digital (BIT) card is actively controlling the output. REMOTE: If BIT card is on (active), LED is on to indicate remote control status. OUT ON: If BIT card is off (not active or not installed), LED is on to indicate output on (enabled) status and off to indicate output off (disabled) status.
6	MODE switch	Operating mode switch to select either Voltage or Current mode.
7	CURRENT meter	I_O d-c digital output ammeter
8	CURRENT control	Provides manual adjustment of BOP d-c output current when CURRENT CONTROL switch set to ON.
9	CURRENT CONTROL switch	Provides manual adjustment of BOP d-c output current when CURRENT CONTROL switch set to ON.
10	I_O Mode indicator	LED lamp, indicating current mode operation.
11	CURRENT PROGRAMMING INPUT terminals	Programming input terminals for current control channel.
12	CURRENT LIMITS (+) control	Control for manual adjustment of the positive (+) current limit.
13	CURRENT LIMIT indicator	LED lamp, indicating current limiting operation.
14	CURRENT LIMITS (-) control	Control for manual adjustment of the negative (-) current limit.
15	SENSE (Output) terminal	Used for OUTPUT sense connection.
16	OUTPUT terminal	Used to connect power supply to load (parallel with rear panel barrier strip terminals).
17	GROUND terminal	Ground terminal (parallel with rear panel barrier strip terminals)
18	COMMON terminal	Provides common return for power supply output (parallel with rear panel barrier strip terminals)
19	SENSE (Common)	Used for COMMON sense connection (parallel with rear panel barrier strip terminals).
20	VOLTAGE LIMITS (+) control	Control for manual adjustment of the positive (+) voltage limit.
21	VOLTAGE LIMIT indicator	LED lamp, indicating voltage limiting operation.
22	VOLTAGE LIMITS (-) control	Control for manual adjustment of the negative (-) voltage limit.
23	E_O Mode indicator	LED lamp, indicating voltage mode operation.
24	VOLTAGE PROGRAMMING INPUT terminals	Programming input terminals for voltage control channel.

TABLE 2-2. BOP REAR PANEL TERMINATIONS AND CONTROLS

FIG. 2-2 INDEX NO.	NAME OF TERMINATION OR CONTROL	FUNCTION
1	PC 15	Rear Programming Connector preconfigured for front panel control. NOTE: Unwired connector (PC 12) is available as an accessory (see Table 1-9).
2	REAR TERMINALS (TB201)	Rear barrier strip with output, sensing and ground terminals.
3	P201	A-C power input jack. accepts 3-wire line cord (supplied).

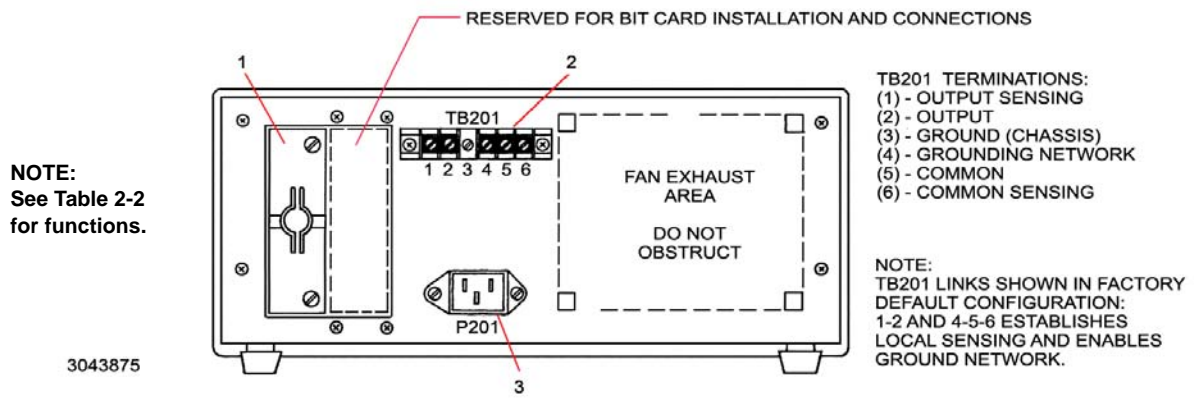

FIGURE 2-2. BOP TERMINATIONS AND CONTROLS, REAR PANEL

2.3 A-C INPUT REQUIREMENTS

This power supply is shipped wired for operation on a single phase, nominal 115V a-c line. For operation on other a-c source voltages, refer to FIG. 2-3. Check your prevailing nominal source voltage and change the links on the barrier strip of T201 according to the table provided in FIG. 2-3. The circuit breaker (CB101) remains equally effective at all input voltages.

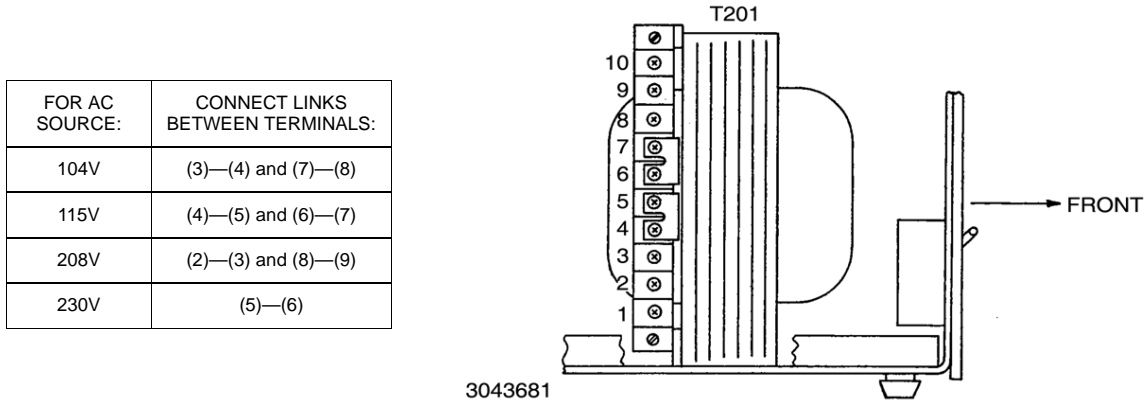

FIGURE 2-3. A-C SOURCE VOLTAGE SELECTION

2.4 COOLING

The components in the BOP power supply rely on forced air cooling for the maintenance of their operating temperature. Side panel openings and the top of the case must be kept clear from all obstructions to ensure air circulation. Periodic cleaning of the interior of the power supply is recommended. **If the BOP is rack-mounted or installed into confined spaces, care must be taken that the ambient temperature (the temperature immediately surrounding the power supply) does not rise above 55°C (~131°F).**

2.5 PRELIMINARY CHECKOUT



CAUTION:The PC 15 connector must be connected for the unit to operate.

NOTES: 1. The Rear Programming Connector supplied with the unit (PC 15) is prewired for local control (see Simplified Schematic Diagram, Figure 3-28) and must be attached to the BOP. An unwired Rear Programming Connector (PC 12) is available as an accessory (see Table 1-9).

2. By default, with no signal at pins 21 and 50 of the rear programming connector, the output is enabled. The output can be controlled, off and on, by logic signals applied to rear programming connector pin 21 referenced to pin 23 (non-isolated control) or pin 50 referenced to pin 48 (isolated control). The logic of the isolated control can be established by the pin 21 signal level; see Table 1-6 for more details.

The default setting of the front panel controls puts the unit in voltage mode with voltage set to zero (Voltage Mode indicator is on).

3. If the unit is set in current mode with no load connected, the unit will go into voltage limit, displaying the preadjusted limit value with the same polarity as the output current offset or current setpoint value. The front panel Voltage Limit indicator will go on and the Current Mode indicator will go off.

A simple operating check after unpacking, and before permanent installation, is advisable to ascertain whether the BOP has suffered damage in shipment. Refer to Figures through 2-2 and Tables 2-1 and 2-2 for the location and function of the operating controls and terminals. Proceed as follows:

1. Connect the BOP to a 115V a-c source, or refer to paragraph 2-4 for conversion to other a-c input voltages if required.

NOTE: The rear sensing links must be attached to the rear barrier strip (TB201) of the BOP as shown in Figure 2-2 and the Rear Programming Connector must be attached and secured.

2. Set the BOP front panel controls as follows. The controls are identified with the nomenclature used in Table 2-1 and the identifying numbers used in Figure 2-1.
 - a) Set MODE switch (6), to VOLTAGE.
 - b) Set VOLTAGE CONTROL switch (2), to ON, and rotate VOLTAGE control (3) to its maximum counterclockwise position.
 - c) Set a-c circuit breaker/POWER switch (1) to ON.

3. At the front panel, E_o MODE indicator (23, Figure 2-1) will be on. REMOTE (W/DIG ON) / OUT ON (W/DIG OFF) (5) indicator will be on to indicate the output is enabled. The front panel VOLTAGE meter (4) will show $-5.25V \pm 0.1V$.
4. Turn the VOLTAGE control (3) clockwise through its range, while observing the front panel VOLTAGE meter. The BOP output voltage should smoothly respond, from the maximum negative output voltage, through zero, to the maximum positive output voltage of the BOP of $+5.25V \pm 0.1V$.
5. At the rear panel, connect a wire jumper between pins 21 and pin 23 of the rear programming connector. Verify the front panel VOLTAGE meter shows zero Volts and the REMOTE (W/DIG ON) / OUT ON (W/DIG OFF) indicator goes off to indicate the output is disabled.
6. At the front panel, turn a-c circuit breaker/POWER switch (1) to OFF.
7. Connect a short circuit between the OUTPUT (16) and the COMMON (18) terminals on the front panel.
8. At the rear panel, remove the wire jumper between pins 21 and 23 of the rear programming connector.
9. Set the BOP front panel controls as follows:
 - a) Set MODE switch (6), to CURRENT.
 - b) Set CURRENT CONTROL switch (9), to ON, and rotate CURRENT control (8) to its maximum counterclockwise position.
 - c) Set a-c circuit breaker/POWER switch (1) to ON.
10. I_o MODE indicator (10) will be on and REMOTE (W/DIG ON) / OUT ON (W/DIG OFF) (5) indicators will be on indicating the unit is in current mode and the output is enabled. The front panel CURRENT (7) meter will show $-21.0A \pm 0.4A$.
11. Turn the CURRENT control (8) clockwise through its range, while observing the front panel CURRENT meter. The BOP output current should smoothly respond, from the maximum negative output current, through zero, to the maximum positive output current of the BOP of $+21.0A \pm 0.4A$.
12. At the rear panel, connect a wire jumper between pins 21 and pin 23 of the rear programming connector. Verify the front panel CURRENT (7) meter shows zero Amperes and the REMOTE (W/DIG ON) / OUT ON (W/DIG OFF) indicator (5) goes off to indicate the output is disabled.
13. Turn a-c circuit breaker/POWER switch (1) to OFF. Remove the short circuit from the output terminals. At the rear panel, remove the wire jumper between pins 21 and 23 of the rear programming connector. This concludes the preliminary check-out of the BOP.

NOTE: If an application requires that the output be OFF at power up and no signal (or logic 0) is to be applied to pin 50 referenced to pin 48 (isolated remote on-off control) of the rear programming connector, then connect a permanent jumper between pins 21 and 23 of the rear programming connector. With this jumper in place, a logic 1 must be applied to pin 50, referenced to pin 48, of the rear programming connector to enable the output. See Table 1-6 for details.

2.6 INSTALLATION OF FULL-RACK BOP MODELS

NOTE: For all installations into confined spaces, care must be taken that the temperature immediately surrounding the unit does not exceed the maximum specified ambient temperature (55° C).

Refer to the Mechanical Outline Drawing, Figure 1-5 for Full Rack models. Full-rack BOP models are delivered with the Fixed Angle Brackets and the Chassis Side Support Bars installed. For bench operation, both of these components may be removed. The full-rack BOP unit may be installed into standard (19-inch) equipment racks, or onto any other flat surface after removing the four (4) bottom aluminum feet. If chassis slides are not used, the BOP may be installed onto any flat surface by means of the provided plastic mounting inserts on the bottom of the BOP chassis.

NOTE: If slide installation (as described below) is not desired, other means of supporting the unit in the rear must be provided (additional rear brackets or a solid platform, for example) since the front angle brackets alone are not sufficient to support the full weight of the unit.

2.6.1 SLIDE INSTALLATION.

The Chassis Slide Support Bars of the BOP are pre-drilled to accept Jonathan Series 110 QD slides. The slides listed in Table 2-3 can be accommodated.

TABLE 2-3. CHASSIS SLIDE MOUNTING HOLES

MODEL	KEPCO P/N	MOUNTING HOLES USED				
		A	B	C	D	E
110 QD-20-2	108-0067	X	X	O	X	DR
110 QD-22-2	108-0156	X	O	X	O	X
110 QD-24-2	108-0192	X	O	X	O	DR

KEY: X = Hole Used
 O = Hole Not Used
 DR = Hole must be drilled into chassis part of slide, each side, 0.199 in. dia., 16-1/4 in. from "A" hole.

To install the slides, refer to Figure 2-4 and proceed as follows:

1. Remove screws "A" through "E" from left and right chassis slide support bars. (Do not discard).
2. Determine the required hole-pattern for the selected slide model from Table 2-3.
3. Drill the "E" hole into both left and right chassis sections of slide if required.
4. Mount the chassis section of the slide to the left and right side of the BOP as shown in Figure 2-4. Use the same 10-32 x 1/2" mounting screws removed in step 1.

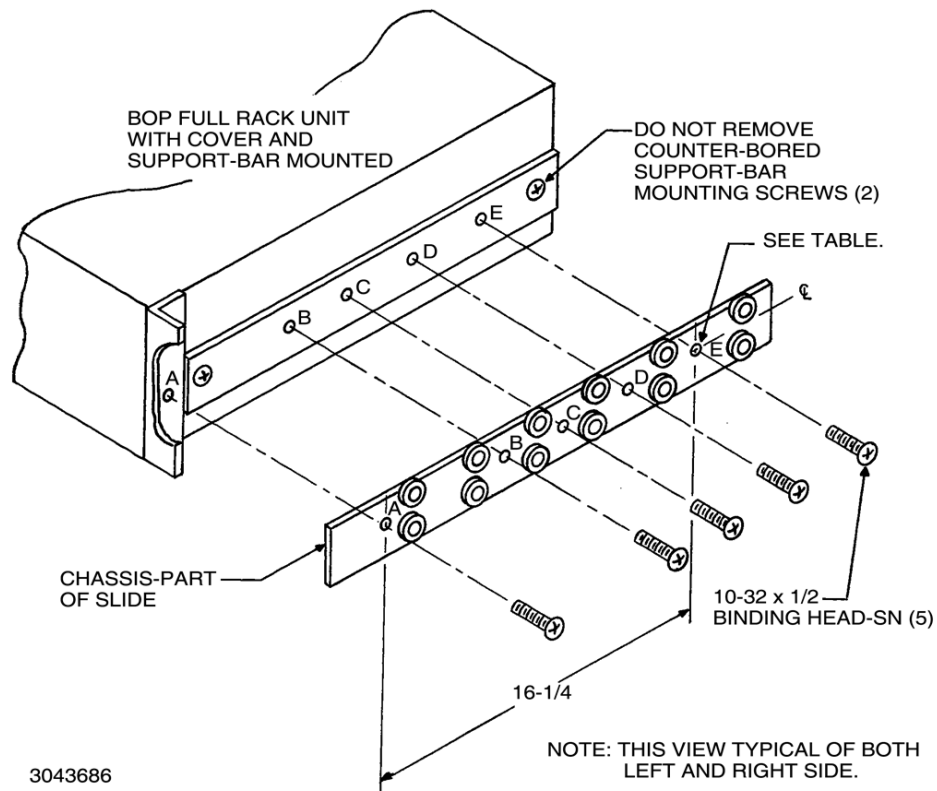

3043686

FIGURE 2-4. SLIDE INSTALLATION ON FULL-RACK UNITS

2.7 LOAD CONNECTION

Load connections to the BOP power supply are achieved via the OUTPUT and COMMON terminals located on the front and rear panels. **Use only one of these output ports.** Sense connections must be made from the same location (front or rear panel) as the output and common power connections.

2.7.1 LOAD CONNECTION, LOCAL SENSING

The basic interconnections between the BOP and the load using local sensing are shown in Figure 2-5 (using the rear panel) and Figure 2-6 (using the front panel).

The load wire size for the 2-wire connection shown should be rated for the nominal output current of the BOP (20A for the BOP 5-20DL, 30A for the BOP 5-30DL) and tied together to keep parasitic inductance low and to reduce possible “pick-up” from stray magnetic fields. The basic 2-wire connection is useful where the voltage drop in the load wires is small or of minor consequence, as for example, operation in constant current mode.

2.7.2 LOAD CONNECTION, REMOTE SENSING

The basic interconnections between the BOP and the load using remote sensing are shown in Figure 2-7 (using the rear panel) and Figure 2-8 (using the front panel). This is the recommended load connection for all applications requiring minimum load effect across a remote load. A twisted or shielded pair of wires (No. 22 AWG minimum) are connected from the BOP sensing terminals to the load. For the BOP 5-20DL and BOP 5-30DL this remote error sensing technique will compensate for load wire voltage drops up to 0.25 volts per wire.

NOTE: Observe polarities: the COMMON sensing wire must go to the COMMON load wire, the OUTPUT sensing wire must go to the OUTPUT load wire.

2.7.3 A-C GROUND

The metal cases of electronic equipment which are operated from the a-c power line must be kept at ground potential at all times. If the 3-wire line cord with 3-prong safety plug (supplied with this equipment) is used in combination with a properly grounded a c power outlet, this is taken care of automatically. If a non-grounded outlet is used, the case must be grounded separately. A separate GROUND terminal is provided for this purpose on the front panel as well as on the rear of the BOP.

The GROUND terminal is connected to chassis of the unit and to the local earth-ground potential through the A-C power line cord. It can be used a) as a grounding point for the output of the unit, and b) for doubling the a-c power cord earth-ground connection if necessary by providing a separate connection to the local earth-ground point.

2.7.4 D-C GROUND

Specified ripple and noise figures listed in Table 1-3 for operational power supplies are valid only with the COMMON side of the output/load circuit returned to an earth-ground point as shown in Figures 2-5 through 2-8.



CAUTION: If the programming device return is tied to earth-ground, leave the BOP output floating. Otherwise, instability and inaccuracy will occur, especially if the programming device return connection is lost.



CAUTION: Do not connect both the load and the programming device return (common) to earth-ground potential and do not use the programming return terminal as a tap point for the load return. Otherwise part of the BOP output current (all current if the COMMON power connection between the BOP and the load is lost) will flow inside the BOP along the programming signal return path, resulting in damage to the unit.

If the application requires, the COMMON of the BOP may be floated up to 500V d-c (or peak) off ground. For this case, due to the common mode noise current flowing through a higher impedance, the resulting ripple/noise will be larger than published specifications. If the application must be grounded, connect a single return/common point of the application (including programming device, BOP and load) to earth-ground. The exact location of the best return earth-ground point must be carefully selected for minimum ripple/noise output.

The GROUNDING NETWORK terminal is tied to GROUND (chassis) terminal through a series capacitor-resistor network. Connecting the GROUNDING NETWORK terminal to the COMMON terminal reduces common noise current flowing through the load and, if a BIT card is installed, it ensures that the dynamic swing of the output does not affect the digital section.

NOTE:
FRONT SENSING LINKS MUST
BE REMOVED. REAR SENSING
LINKS MUST BE CONNECTED
AS SHOWN.

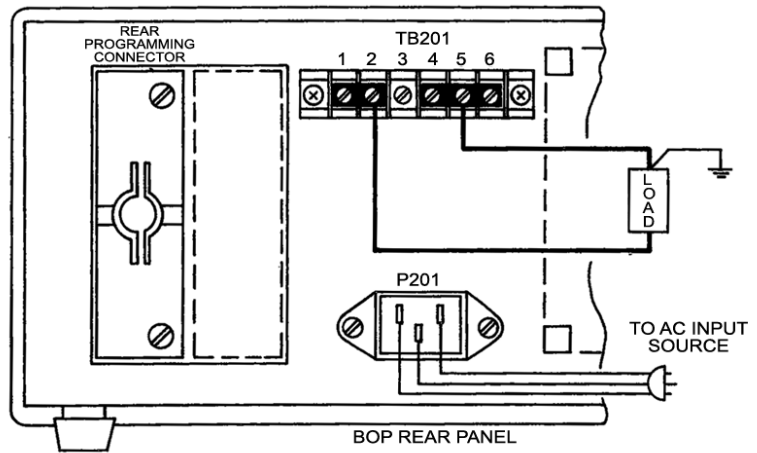

3043878

FIGURE 2-5. LOAD CONNECTION USING LOCAL SENSING AT REAR PANEL

NOTE:
REAR SENSING LINKS MUST BE
REMOVED. FRONT SENSING LINKS
MUST BE CONNECTED AS SHOWN.

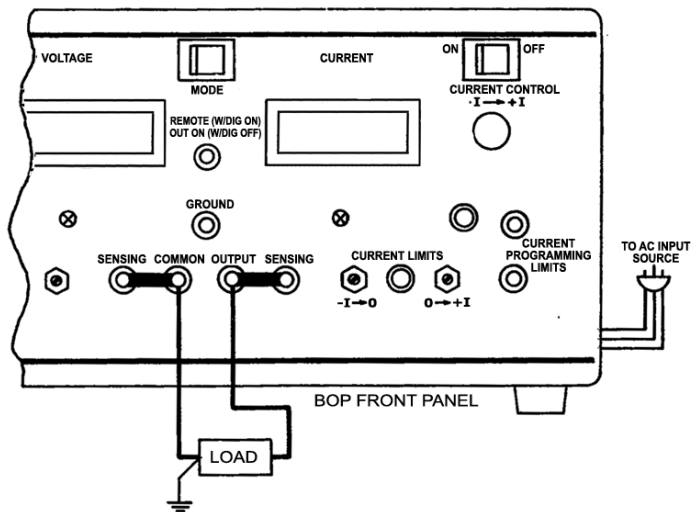

3043688

FIGURE 2-6. LOAD CONNECTION USING LOCAL SENSING AT FRONT PANEL

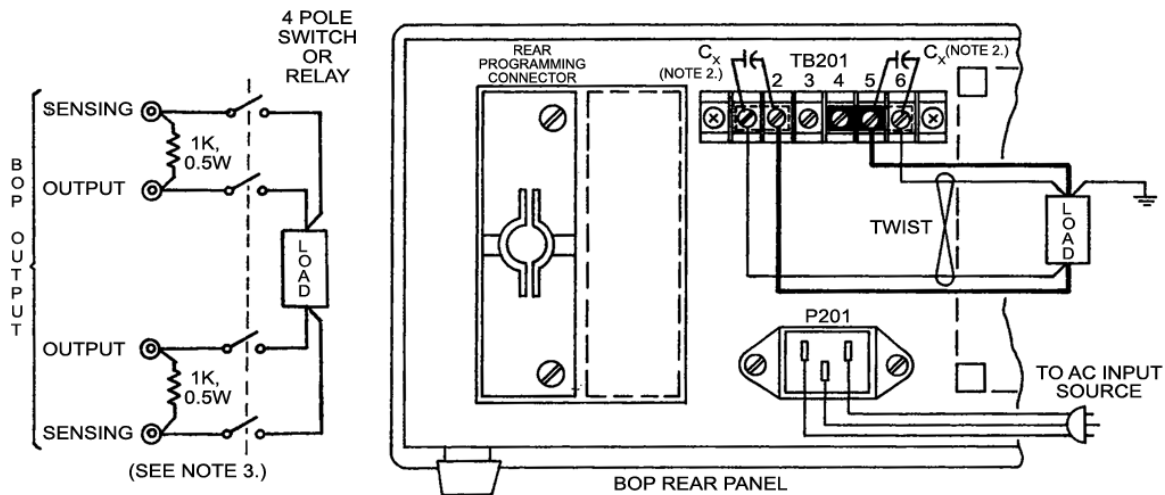

NOTES:

1. Front and rear sensing links must be removed.
2. For applications requiring very long connections to the load, additional external capacitors (C_x) should be connected as shown to compensate for the lead inductance of the connecting wires.
3. For applications requiring manually switched or relay driven output connections, external resistors must be connected as shown. All connections must be made and broken simultaneously.

3043879

FIGURE 2-7. LOAD CONNECTION USING REMOTE SENSING AT REAR PANEL

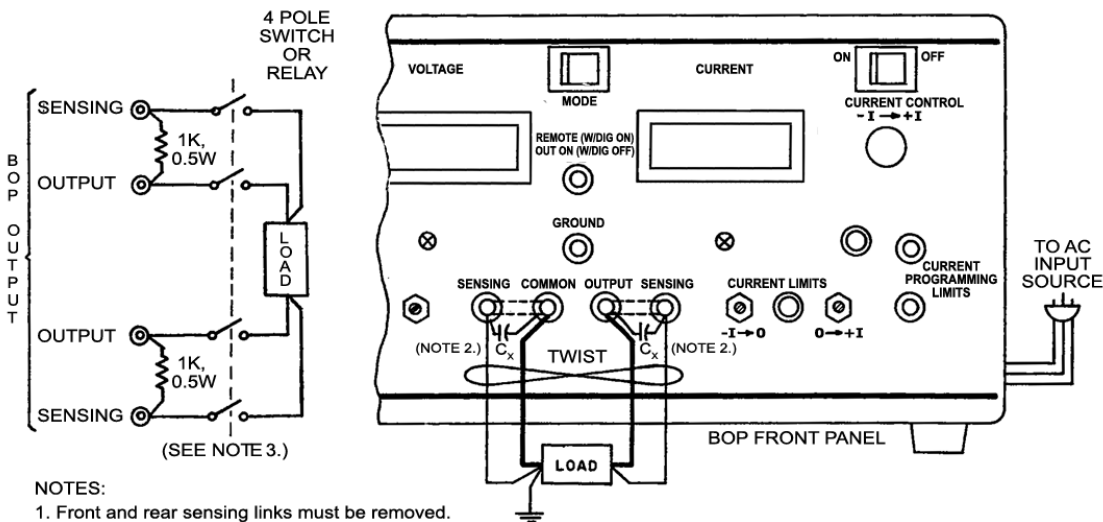

NOTES:

1. Front and rear sensing links must be removed.
2. For applications requiring very long connections to the load, additional external capacitors (C_x) should be connected as shown to compensate for the lead inductance of the connecting wires.
3. For applications requiring manually switched or relay driven output connections, external resistors must be connected as shown. All connections must be made and broken simultaneously.

3043880

FIGURE 2-8. LOAD CONNECTION USING REMOTE SENSING AT FRONT PANEL

SECTION 3 - OPERATION

3.1 INTRODUCTION

BOP Bipolar Operational Power Supplies can be used in a great variety of applications. As a precision voltage or current source, the BOP output can be controlled locally by means of the front panel bipolar VOLTAGE and CURRENT controls or remotely by means of resistance or voltage signals or an optional digital interface (see PAR. 3.42). Independently adjustable or remotely programmable limit circuits for both output voltage and output current protect a sensitive load from any overvoltage or overcurrent.



NOTE: Before using the BOP in any application, please refer to Section 2 to get acquainted with the operating controls, a-c power requirements and information on load connections and grounding. Front panel components identified by index numbers in parentheses are shown in Figure 2-1.

3.2 POWER SUPPLY BASICS

As a Bipolar Amplifier, the BOP output responds to such input signals as sine, square or triangular waves. A ± 10 volt input signal will program the BOP output (voltage or current) through its rated output ranges. Built-in preamplifiers, for the voltage, as well as the current channel of the BOP, permit amplification of the control signals to the required amplitude and provide the interface with high, as well as low, impedance signal sources.

Detailed examples of the more popular applications are described in the following paragraphs. Before actual operation, however, the following safety precautions must be carefully considered.



WARNING

Exercise care in making all connections to and from the BOP terminals. Remove a-c power from the BOP before making any connections.

Wires and/or cables connected from the BOP terminals to external components or programming devices must be properly insulated and securely terminated on both sides to make accidental touch impossible. Do not use banana plugs with exposed screws or other exposed metal parts at the front panel output terminals!

The BOP chassis and cover must be safety-grounded to a reliable a-c source ground. A safety-ground may be established by using a grounded a-c power outlet or, if the latter is not available, by means of a separate wire from the provided GROUND terminal to a reliable a-c source ground point.

The COMMON output terminal of the BOP can be either grounded or floating, depending on the application. Additional precautions must be taken to make any user access to the output terminals impossible.

Application and test set up diagrams on the following pages show the symbolic and simplified representation of the four programmable circuits of the BOP:

- Voltage Control Channel: see Figure 3-1 and PAR. 3.3.1 for local control.
- (\pm) I_O Limit Circuits: See Figure 3-2 and PAR. 3.3.2 for local control.
- Current Control Channel: see Figure 3-3 and PAR. 3.3.3 for local control.
- (\pm) E_O Limit Circuits: see Figure 3-4 and PAR. 3.3.4 for local control.

The complete simplified diagram is shown in Figure 3-28 at the end of this section. The four circuits can be programmed separately as described in the examples in this section, or one main channel and two limit channels can be used simultaneously as the application requires. The two main bipolar voltage and current channels are manually selected by the front panel MODE switch.

The numbered terminals in the simplified diagrams of this section correspond to the terminals of the Rear Programming Connector (see Figure 3-29 at the end of this section. The terminal designated C (Common) corresponds to terminals numbers 23, 25, 27, 29, 31 or 33 on the Rear Programming Connector

NOTE: BOP'S have front and rear output terminals. Only the front terminals are shown on all subsequent simplified diagrams.

3.2.1 EXTERNAL PROGRAMMING RESISTORS.

External programming resistors should be high-quality units, with low-temperature coefficients. Resistors should be selected carefully, since in most applications, the limitations for stability and drift are due not to the BOP, but to the programming resistors. Selection criteria for resistors are:

- Temperature coefficient
- Leakage (in values above 100k ohm)
- Humidity effects
- Drift with time
- Self-heating (power dissipation)
- Tolerance.

For variable resistors (potentiometers or rheostats) similar selection criteria apply. In addition, such specifications as listed below should be carefully considered if the application requires:

- End resistance
- Linearity
- Capacitive and inductive effects

3.2.2 ACTIVE PROGRAMMING SOURCES

External programming sources (Signal Generators, etc.) or reference sources should have temperature coefficients and drift specifications comparable to (or better than) the BOP Power Supply.



CAUTION: A-C source-operated programming sources must have their output isolated from the case.

3.2.3 EXTERNAL LEADS

Shielded (preferably twisted) lead pairs are recommended for all input connections to the BOP control channels. The shield should be connected (single-ended) to the chosen signal ground point. Shielded leads should be held as short as practicable. Output leads must be voltage-rated for at least the maximum BOP output voltage and current.

3.2.4 EXTERNAL VOLTAGE MONITOR

Use Voltage Monitoring signal at pin 20 of the Rear Programming Connector (see Figure 3.2.1 for external voltage monitoring). The range of this signal is 0 to $\pm 10V$ for 0 to $\pm 5V$ at the output. The Voltage Monitoring signal comes from a matched power resistor divider and is buffered by an op-amp. This stage is protected against short-circuit by the intrinsic protection of the op-amp. This signal is used by the BIT card if it is installed. The return for the Voltage Monitoring signal can be any of the signal return pins (23, 25, 27, 29, 31 or 33) of the rear programming connector.

3.2.5 EXTERNAL CURRENT MONITOR

Use the Current Monitoring signal at pin 10 of the Rear Programming Connector (see Figure 3.2.1) for external current monitoring. The range of this signal is 0 to $\pm 10V$ for 0 to $\pm 20A$ at the output. An op-amp buffers the Feedback/Sensing signal in order to create the Current Monitoring signal. There is no overvoltage protection. This stage is protected against short-circuit by the intrinsic protection of the op-amp generating this signal. This signal is used by the BIT card if it is installed. The return for the Current Monitoring signal can be one of the signal return (signal common) pins (23, 25, 27, 29, 31 and 33) of the rear programming connector.

3.3 LOCAL (FRONT PANEL) OUTPUT CONTROL

3.3.1 VOLTAGE MODE OPERATION WITH CURRENT LIMITING.

The BOP may be used as a stabilized (d-c) source of positive or negative voltage with output current limiting (for either polarity) pre-selected for the application at hand.

Figure 3-1 illustrates the voltage control circuit configured for local (front panel) control using local sensing.

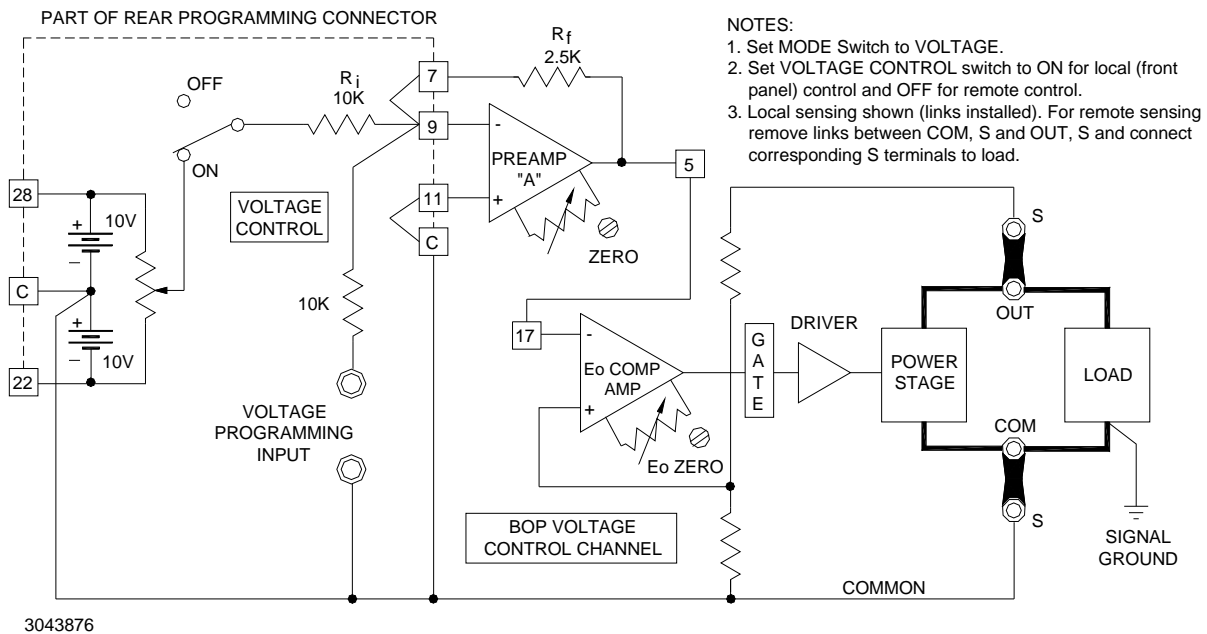

- NOTES:
1. Set MODE Switch to VOLTAGE.
 2. Set VOLTAGE CONTROL switch to ON for local (front panel) control and OFF for remote control.
 3. Local sensing shown (links installed). For remote sensing remove links between COM, S and OUT, S and connect corresponding S terminals to load.

FIGURE 3-1. BOP VOLTAGE CONTROL CHANNEL (LOCAL CONTROL, LOCAL SENSING)

Proceed as follows:

1. Determine the output voltage and current requirements of your load. Set the BOP MODE switch (8, Figure 2-1) to VOLTAGE and the VOLTAGE CONTROL switch (4) to ON.
2. With the POWER circuit breaker/switch (2) set to OFF, connect a short circuit across the output terminals and set POWER to ON again.
3. Adjust CURRENT LIMITS controls for $-I$ (18) and $+I$ (16) polarities as required, monitoring the output CURRENT meter (11) for the correct limiting value. Proceed as follows:
 - a. Turn VOLTAGE control (3) fully counterclockwise.
 - b. Adjust $-I$ CURRENT LIMITS control (18) as required.
 - c. Turn VOLTAGE control (3) fully clockwise.
 - d. Adjust the $+I$ CURRENT LIMITS control (16) as required.
 - e. Turn VOLTAGE control (3) to the center of its range.
4. Set POWER circuit breaker/switch to OFF; remove the short circuit from the output and reconnect the load.

NOTE: If the output current exceeds the preadjusted value at any time, the Voltage Mode indicator (26) will go out and the CURRENT LIMITS indicator (17) will go on. After the cause of the overcurrent is eliminated, the indicators will return to their initial status.

3.3.2 LOCAL CONTROL OF CURRENT LIMITING

Figure 3-2 shows the Current Limiting circuit configured for local sensing and local (front panel) control.

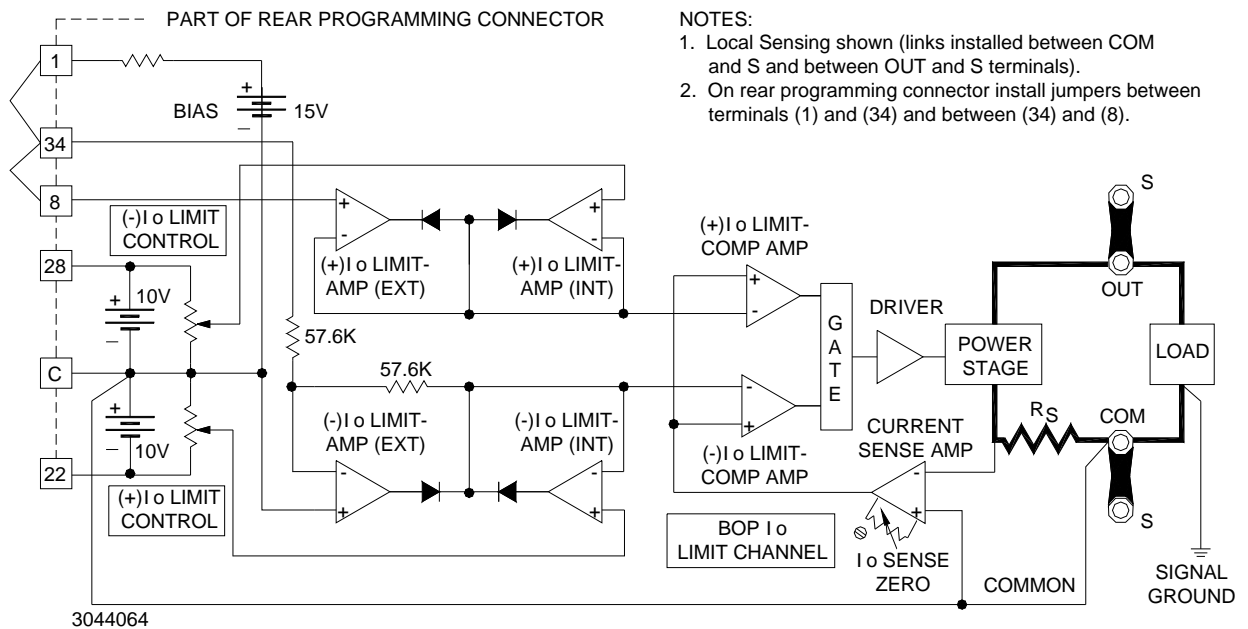

FIGURE 3-2. BOP (±) CURRENT LIMITING CIRCUIT (LOCAL CONTROL, LOCAL SENSING)

The output current is sensed by the current sensing resistor R_S . The voltage drop across R_S is proportional to the output current value and is amplified by the Current Sensing amplifier and applied to the input to the (-) I_O Limit Comparison amplifier and to the (+) I_O Limit Comparison amplifier. In the local (front panel) control mode, as well as in the external control mode, a 0 to 10 volt signal, applied at the inverting inputs of the $\pm I_O$ Limit Comparison amplifiers, will control the current limit point over the entire output current range: 0.5% to 110% of nominal for local and remote control. For the internal (front panel) control mode, the control signal is derived across both 10 volt reference sources, applied by means of the $\pm I_O$ Limit controls to the internal $\pm I_O$ Limit amplifiers and directed to the respective inputs of the $\pm I_O$ Limit Comparison amplifiers. In the internal control mode, both $\pm I_O$ Limit Amplifiers (EXT) are biased off by the 15V bias source.

3.3.3 CURRENT MODE OPERATION WITH VOLTAGE LIMITING.

The BOP may be used as a stabilized d-c source of positive or negative current, with output voltage limiting (for either polarity), pre-selected for the application at hand. Figure 3-3 illustrates the current control circuit configured for local (front panel) control using local sensing.

With CURRENT CONTROL switch (12, Figure for 3/4 rack, Figure 2-1 for full rack) set to ON (closed), and MODE switch (8) set to CURRENT, output current can be controlled by means of the CURRENT CONTROL (13) over the full output range. The control potential (zero to $\pm 10V$) is applied via Preamp "B," operating with unity gain, to the I_o Comp. Amp which drives the Power Stage with a fixed gain as listed in Table 1-2.

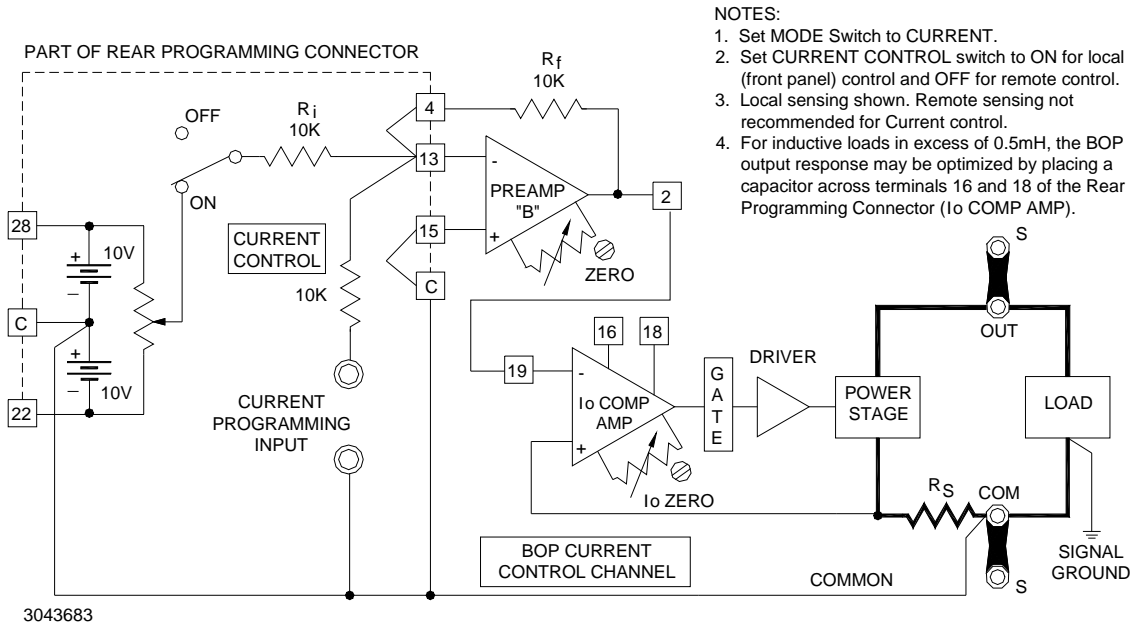

FIGURE 3-3. BOP CURRENT CONTROL CHANNEL (LOCAL CONTROL, LOCAL SENSING)

Proceed as follows:

1. Determine the output voltage and current requirement of your load. Set the MODE switch (8, Figure 2-1) to CURRENT and the CURRENT CONTROL switch (12) to ON.
2. With the POWER circuit breaker/switch (2) set to OFF, disconnect the load. Set the POWER circuit breaker/switch to ON again.
3. Adjust the VOLTAGE LIMITS controls for $-V$ (25) and $+V$ (23) polarities as required, monitoring output VOLTAGE meter (5) for the voltage limiting value. Proceed as follows:
 - a. Turn CURRENT CONTROL (13) fully counterclockwise.
 - b. Adjust $-V$ VOLTAGE LIMITS control (23) as required.
 - c. Turn CURRENT CONTROL (13) fully clockwise.
 - d. Adjust $+V$ VOLTAGE LIMITS control (25) as required.
 - e. Turn CURRENT CONTROL (13) to the center of its range.
 - f. Set POWER circuit breaker/switch (2) to OFF and reconnect the load.

- Set POWER circuit breaker/switch (2) to ON again, and adjust the operating current by means of CURRENT CONTROL (13) to the value required.

NOTE: If the output voltage exceeds the preadjusted value at any time the Current Mode indicator (15) will go out and the VOLTAGE LIMITS indicator will go on. After the cause of the overvoltage is eliminated, the indicators will return to their initial status.

3.3.4 LOCAL CONTROL OF VOLTAGE LIMITING

Figure 3-4 shows the Voltage Limiting circuit configured for local sensing and local (front panel) control. The circuit functions in a manner similar to the I_O Limit circuit described previously (refer to PAR. 3.3.2), except that the voltage limit feedback is derived by means of a voltage divider across the BOP output.

In the local (front panel) control mode, as well as in the external control mode, a 0 to 10 volt signal, applied at the inverting inputs of the $\pm E_O$ Limit Comparison amplifiers, will control the voltage limit point over the entire output current range of each BOP model. For the internal (front panel) control mode, the control signal is derived across both 10 volt reference sources, applied by means of the $\pm E_O$ Limit controls to the internal $\pm E_O$ Limit amplifiers and directed to the respective inputs of the $\pm E_O$ Limit Comparison amplifiers. In the internal control mode, both $\pm E_O$ Limit Amplifiers (EXT) are biased off by the 15V bias source.

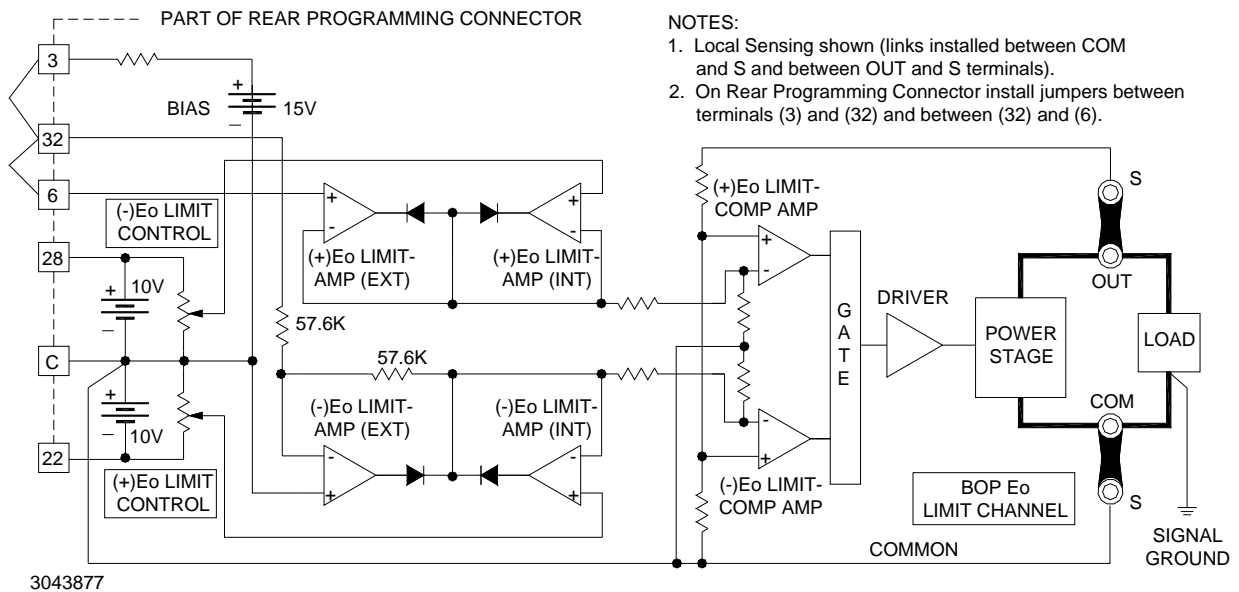

FIGURE 3-4. BOP (\pm) VOLTAGE LIMITING CIRCUIT (LOCAL CONTROL, LOCAL SENSING)

3.4 REMOTE CONTROL OF VOLTAGE CHANNEL

Remote control of the voltage channel is accomplished by using an external configuration to substitute for the internal control voltage produced by the front panel VOLTAGE CONTROL.

3.4.1 REMOTE VOLTAGE CONTROL USING RESISTANCE (POTENTIOMETER)

When configured as shown in Figure 3-5, Preamp “A” with the built-in feedback and input resistors has a gain of one and the fixed gain of all BOP models is designed so that a d-c input signal of zero to (±)10 volts will control the BOP output through its specified range. When the front panel VOLTAGE CONTROL switch (4, Figure for 3/4 rack, Figure 2-1 for full rack) is set to OFF, operation is similar to local control described in PAR. 3.3.1, except that an external potentiometer is substituted for the front panel VOLTAGE control (3).

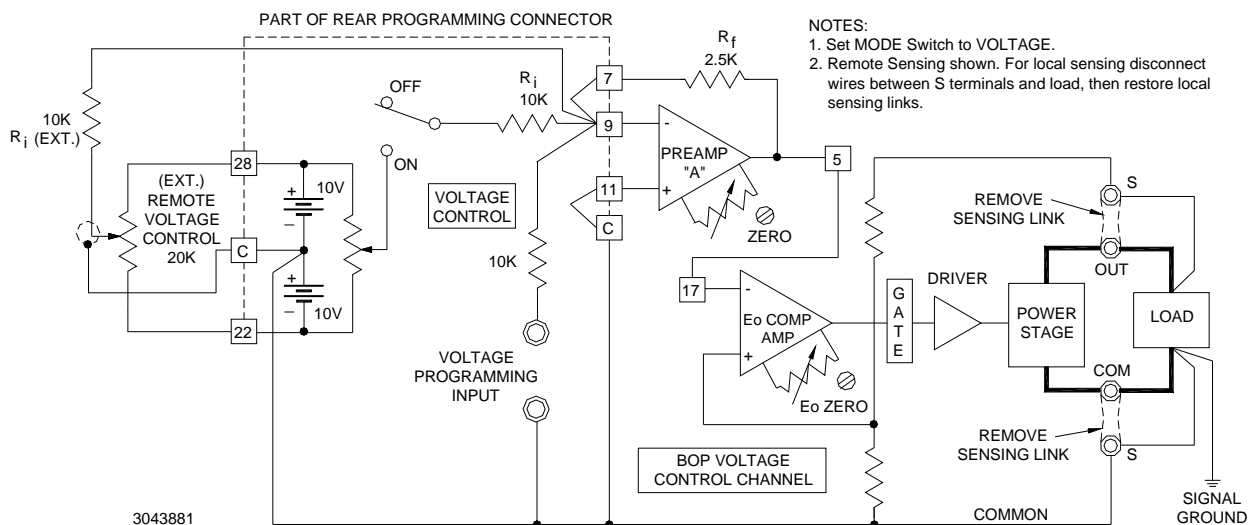

FIGURE 3-5. REMOTE POTENTIOMETER CONTROL OF D-C OUTPUT VOLTAGE

3.4.2 REMOTE VOLTAGE CONTROL USING RESISTANCE (DECADE BOX)

Two-terminal resistance control of the d-c voltage (for example, by means of a Decade Box (make-before-break type) or any variable resistance) can be exercised as shown in Figure 3-6.

The external switch (S1), connected across the (±) reference voltage, is used to pre-select either positive or negative output by setting it to the applicable reference voltage polarity.

PREAMP “A” functions here as an inverter. Its output can be expressed by the equation:

$$E_O (\text{PREAMP "A"}) = -E_{\text{ref}} (R_f/R_i). \text{ where}$$

- R_f = Decade Resistor.
- R_i = Ext. Input Resistor

The BOP output voltage will vary linearly with the change in decade resistance.

This programming system can be calibrated very accurately by setting the external Remote Voltage Control (Decade) to zero, and adjusting for zero output volts using the screwdriver-adjusted E_O ZERO control while monitoring the BOP output with a digital voltmeter. The maximum output voltage is calibrated by making all or part of R_i a rheostat and adjusting it with the Remote Voltage Control at maximum resistance, to the maximum BOP output voltage.

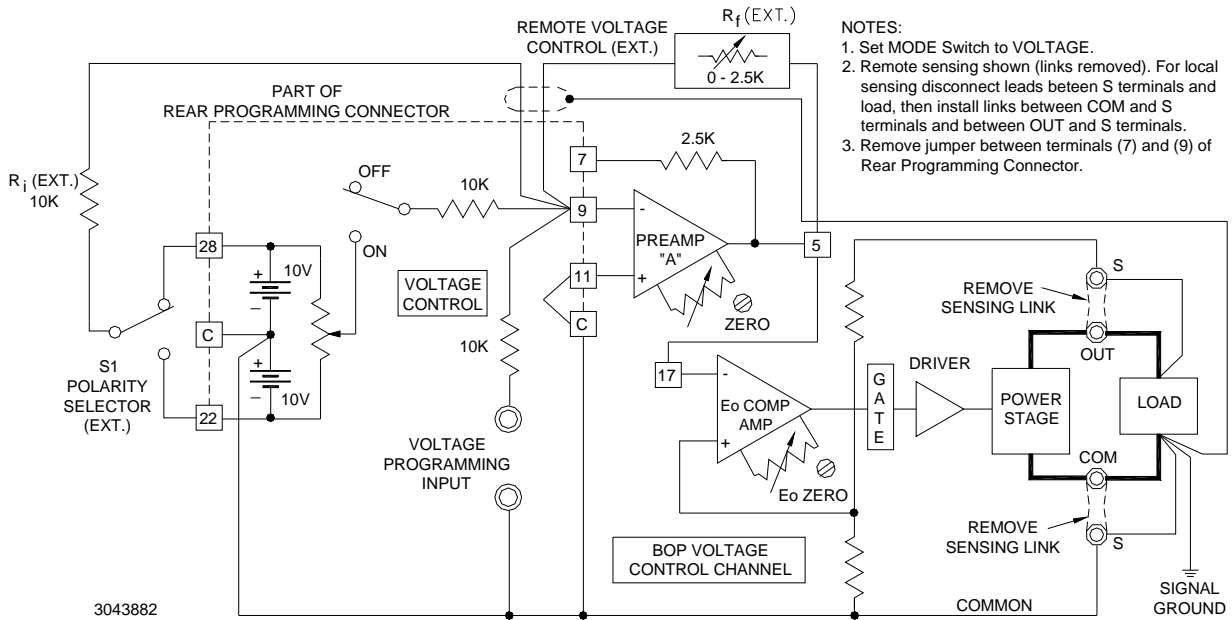

FIGURE 3-6. REMOTE D-C OUTPUT VOLTAGE CONTROL USING TWO-TERMINAL RESISTANCE (DECADE)

3.4.3 REMOTE VOLTAGE CONTROL USING D-C SIGNAL VOLTAGE

The BOP d-c output voltage can be controlled directly by a $\pm 10\text{V}$ d-c signal, applied to the front panel Voltage Programming Input terminals. An interesting example of how this can be implemented is the use of a Kepco SN Digital Programmer to convert digital input to the analog $\pm 10\text{V}$ d-c signal. The digital input to the SN programmer can be provided by a computer, or manually by means of a keyboard. The analog output from the SN is from zero to ± 10 volts and constitutes the input programming voltage for the BOP.

The connections between the SN Programmer and the BOP are illustrated in Figure 3-7. This programming system provides a resolution of 12-bits with a linearity of $(\pm)1/2$ LSB (0.0122%). The digital and the power supply grounds are isolated (optical isolation) to 1000 volts. Calibration of the system is performed with the provided controls on the SN Programmer.

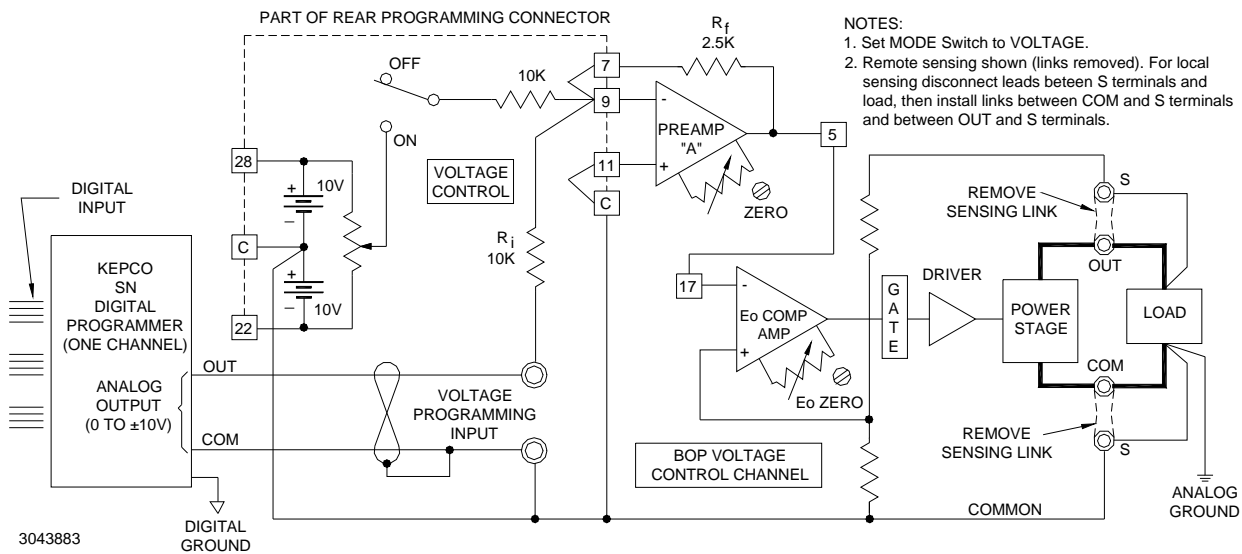

FIGURE 3-7. DIGITAL CONTROL OF THE D-C OUTPUT VOLTAGE

Since all terminals of Preamp "A" are available at the Rear Programming Connector, d-c output voltage control can be exercised in many other ways. Preamp "A" can be treated as an uncommitted operational amplifier, with its applicable transfer functions. Its initial offsets can be zeroed with the provided control, while the offset variations are specified Table 1-3). The basic principle of d-c output voltage control of the BOP is that a control voltage of (\pm)10 volts at 1 mA at the Voltage Programming Input (with the built-in feedback/input resistors) will produce the full d-c output voltage swing of the BOP. If the selected control signal does not have the required amplitude or if the required control current cannot be supplied, the Preamp "A" configuration can be altered to provide the proper interface for the application.

For example, if the BOP d-c output is to be controlled by means of a bipolar, 1 volt, high impedance source, it can be connected to the BOP as shown in Figure 3-8.

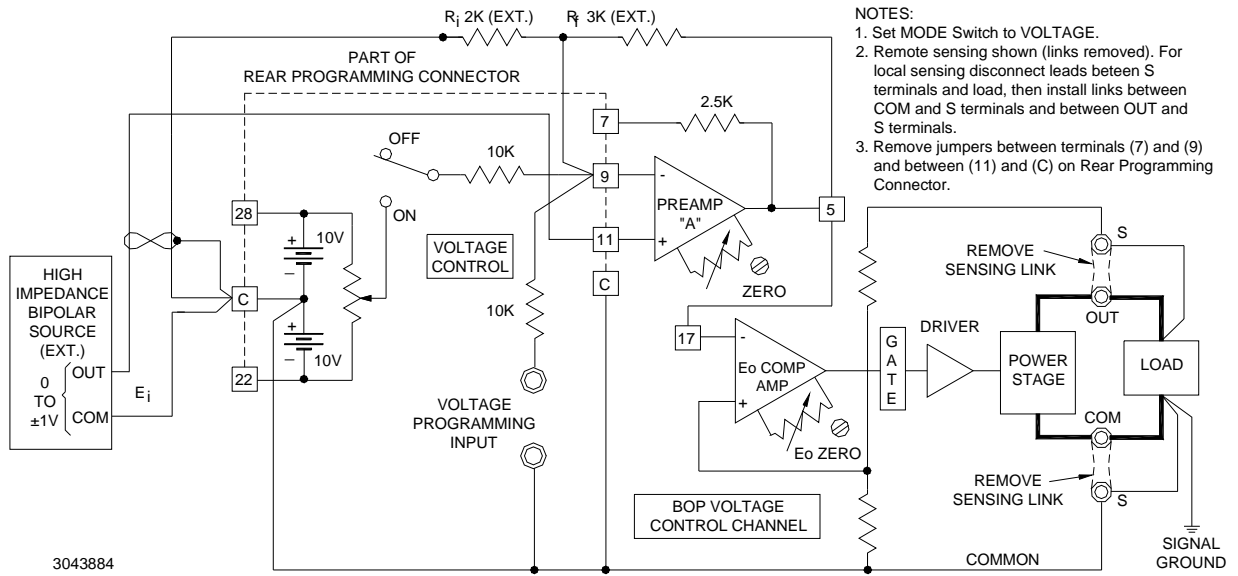

FIGURE 3-8. D-C OUTPUT VOLTAGE CONTROL WITH NON-INVERTING CONFIGURATION AND HIGH IMPEDANCE ±1V SIGNAL SOURCE

As seen in Figure 3-8, the original input feedback components of Preamp "A" have been bypassed and are replaced by external resistors (metal film or wire-wound type resistors may be used and connected directly to the Rear Programming Connector terminals as shown). Preamp "A" is used in the non-inverting configuration, so the output voltage will have the same polarity as the input programming signal. Its output voltage (the necessary BOP control voltage) is given by:

$$E_{O(\text{PREAMP "A"})} = E_i \frac{R_f + R_i}{R_i} \quad \text{or} \quad E_{O(\text{PREAMP "A"})} = (\pm 1V) \frac{3K\text{Ohms} + 2K\text{Ohms}}{2K\text{Ohms}} = \pm 2.5V$$

$$E_{O(\text{unit})} = (\pm 2.5V) (2V/V) = \pm 5V$$

Consequently, as the bipolar input voltage (E_i) is controlled from $-1V$ through zero to $+1V$, the BOP output voltage will follow over its specified range. Calibration of the system can be performed at the programming source, or the Preamp "A" ZERO and E_o ZERO controls can be used for the zero adjustment, while the feedback resistor ($R_f = 3K \text{ Ohms}$) can be trimmed to calibrate full scale.

3.4.4 USING THE BOP AS A VOLTAGE AMPLIFIER

If, instead of the d-c control signal (see PAR. 3.4.3), an a-c signal voltage is applied to the Voltage Programming Input terminals, the BOP functions as a bipolar amplifier. As an amplifier, the BOP voltage gain is set on each BOP model so that (as with the d-c control signal) a bipolar a-c input signal with an amplitude of 0V to 20V (peak-to-peak) will drive the BOP output through its specified (\pm) output voltage range. All other dynamic specifications are given in Table 1-5.

The BOP can be used to amplify, sum or scale a variety of waveshapes, some of which are illustrated in Figure 3-9. All input signals are shown 180° out of phase with their corresponding output waveshapes. The latter can be readily produced in phase (i.e. with the output wave taking the same direction as the input signal) by addressing the non-inverting input of Preamp "A" instead of the front panel Voltage Programming Input terminals (inverting).

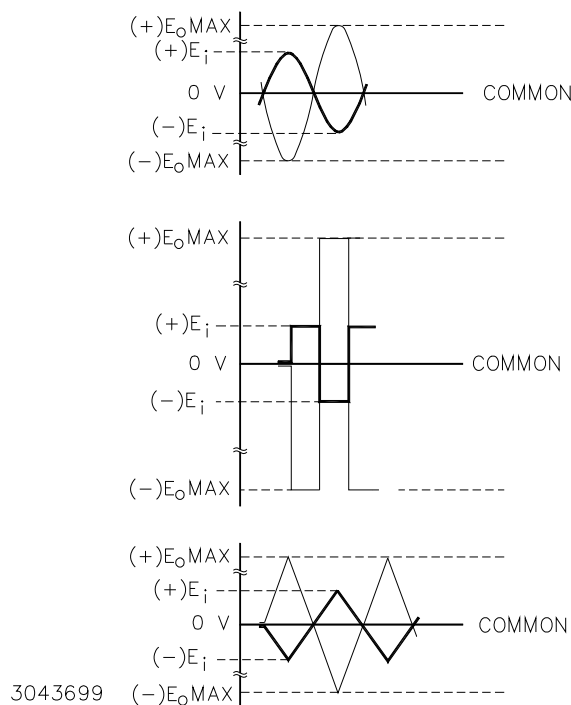

FIGURE 3-9. GRAPHS OF POSSIBLE INPUT/OUTPUT WAVESHAPES

The basic programming circuit used to produce the waveforms shown in Figure 3-9 is shown in Figure 3-10. Since all input signals of Figure 3-9 are shown with a ± 10 volts amplitude, the basic programming circuit in Figure 3-10 must be modified if the external signal source cannot produce 10 volts and if the full BOP output voltage swing is required.

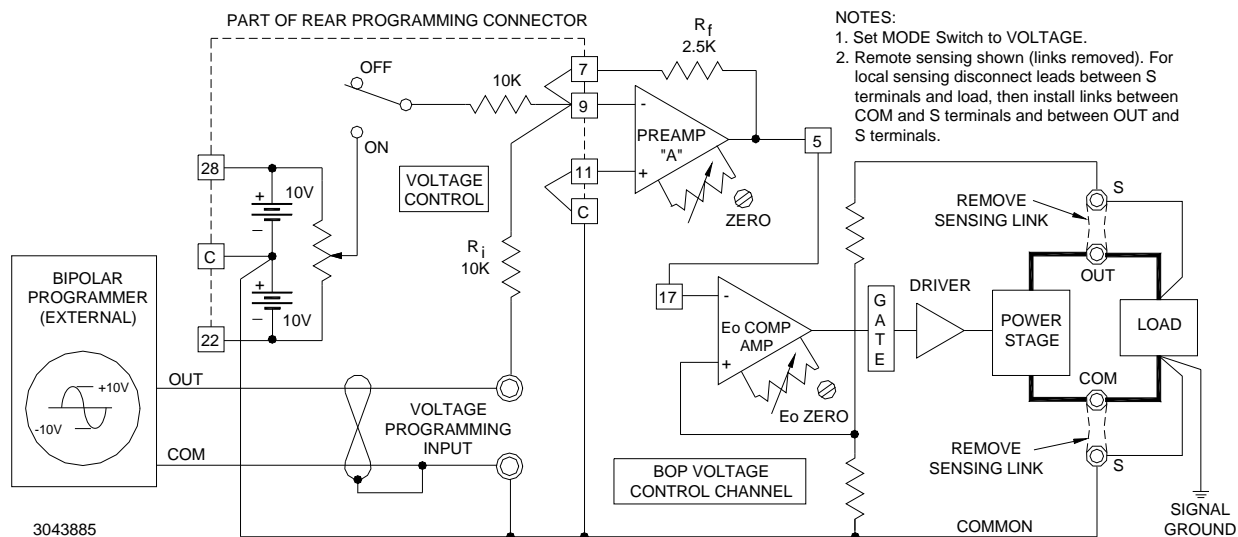

FIGURE 3-10. BASIC PROGRAMMING CIRCUIT FOR USE OF BOP AS BIPOLAR AMPLIFIER (VOLTAGE MODE)

If the external programming source does not have sufficient amplitude to drive the BOP over its full output range, the gain of Preamp "A" must be changed from the built-in value to suit the application. To calculate the required components for the new gain requirement, the output equation for Preamp "A" in the inverting configuration is used:

$$E_O (\text{PREAMP "A"}) = -E_i (R_f/R_i)$$

where $E_O (\text{Preamp "A"}) = \pm 2.5\text{V}$, and the values of R_f and R_i depend on the available amplitude of the programming source. If, for example, a ± 1 volt source is available, the ratio R_f/R_i must be 2.5, and the two resistor values can be 10K and 25K respectively. The built-in resistor ($R_i = 10\text{K}$) can be retained, and only R_f must be replaced with a 25K metal film (1/2 watt) resistor. The necessary connections are illustrated in Figure 3-11. Gain control can be exercised by making R_f a rheostat instead of a fixed resistor.

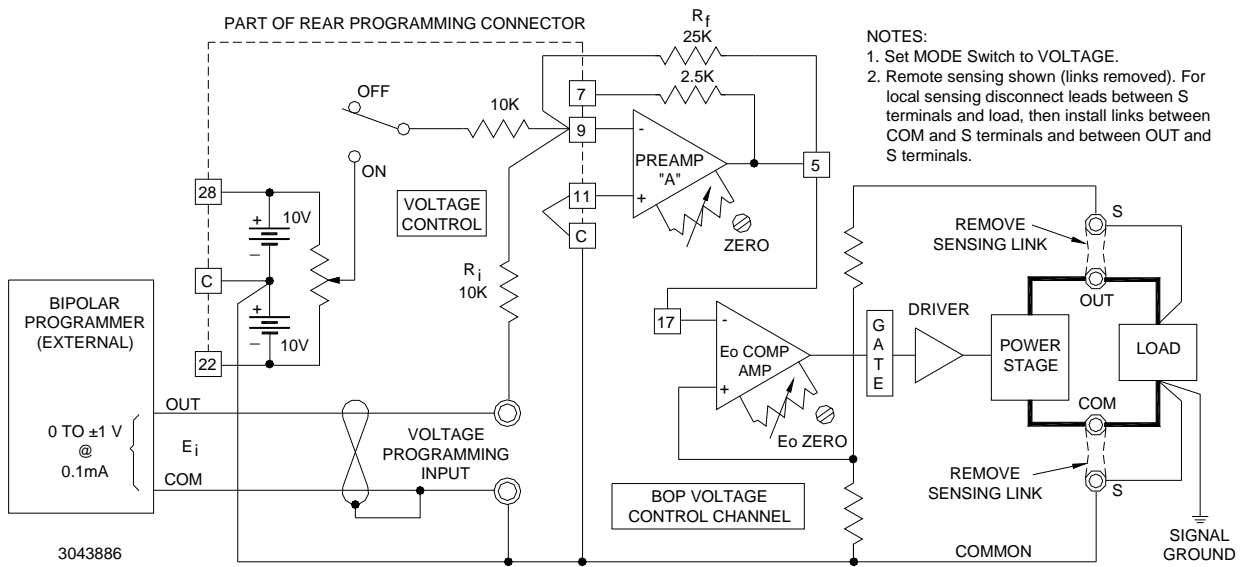

FIGURE 3-11. PROGRAMMING CIRCUIT FOR DRIVING OUTPUT VOLTAGE WITH

3.4.5 REMOTE CONTROL OF CURRENT LIMITING

For remote control of current limiting, the $\pm I_O$ Limit Amplifiers (EXT) are disconnected from the 15V Bias source by removing jumpers between (1) - (34) and (34) - (8) at the Rear Programming Connector (see Figure 3-12). An external 0 to +10V control signal is applied to terminals 8 and 34, with reference to common. This control signal programs both the negative and positive current limit simultaneously and symmetrically over the BOP output current range.

If individual control of the \pm current limits is desired, the jumper between (8) and (34) at the Rear Programming Connector must be removed and separate control sources must be connected: 0 to +10 volts to pin 8 for the $+I_O$ limit, and 0 to +10 volts to pin 34 for the $-I_O$ limit, both with reference to common (see Figure 3-13).

NOTE: The front panel $\pm I_O$ LIMIT controls serve as a back-up when external current limit programming is used. These controls should be set to a value slightly larger than the external current limits that are to be programmed.

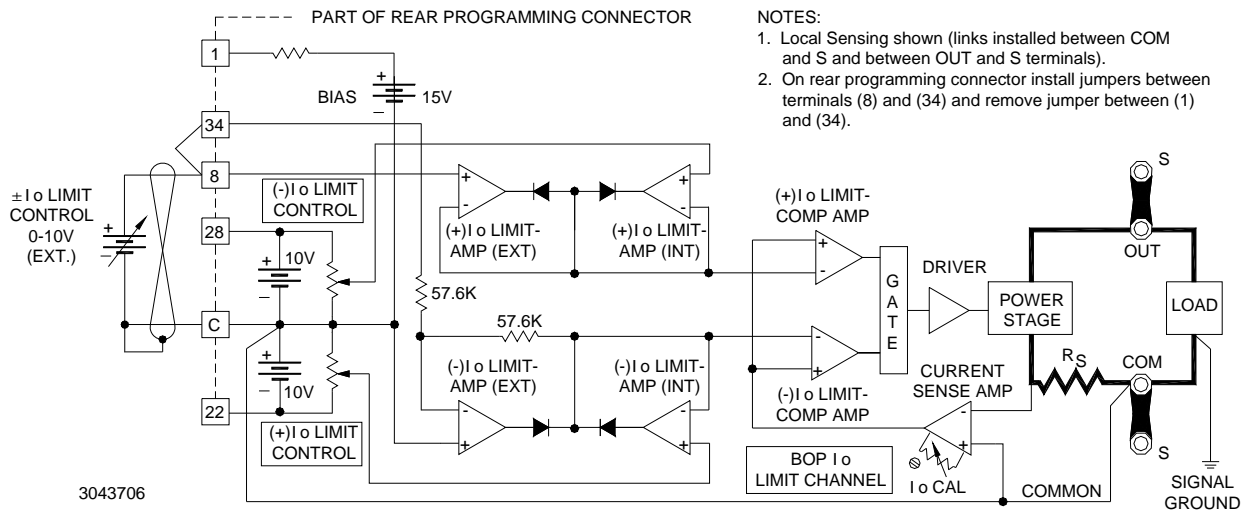

FIGURE 3-12. SYMMETRICAL REMOTE CONTROL OF THE CURRENT LIMITS

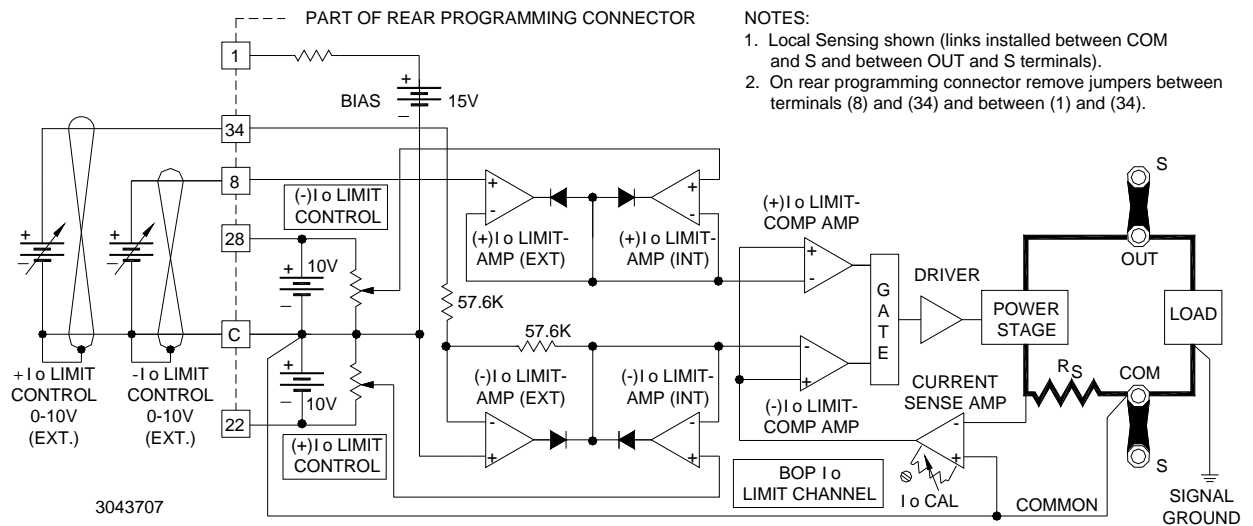

FIGURE 3-13. INDEPENDENT REMOTE CONTROL OF + I_O AND - I_O LIMITS

3.5 REMOTE CONTROL OF CURRENT CONTROL CHANNEL

Since the input signal requirements for the control of the BOP output current are the same as for programming the output voltage, and since the control circuitry of the current channel is almost identical to that of the voltage channel, all programming circuit descriptions for programming the output voltage of the BOP can be applied to current programming. The current programming circuits are illustrated in the following diagrams. Any comments specifically applicable to current channel programming are noted on the diagrams.

NOTE: Adjust the zero output current point by means of the built-in ZERO control of Preamp "B" or that of the I_O Comp. Amp.

3.5.1 REMOTE CURRENT CONTROL USING RESISTANCE (POTENTIOMETER)

Similar to the local (front panel) control mode described in PAR. 3.3.3, the BOP output current can be controlled over the full output range by means of an external resistance in place of the front panel CURRENT CONTROL as shown in Figure 3-14. The control potential (zero to $(\pm)10V$) is applied via Preamp "B," operating with unity gain, to the I_o Comp. Amp which drives the Power Stage with a fixed gain as listed in Table 1-2. A d-c control signal from zero to $(\pm)10V$ will, therefore, control the BOP output current through its specified range.

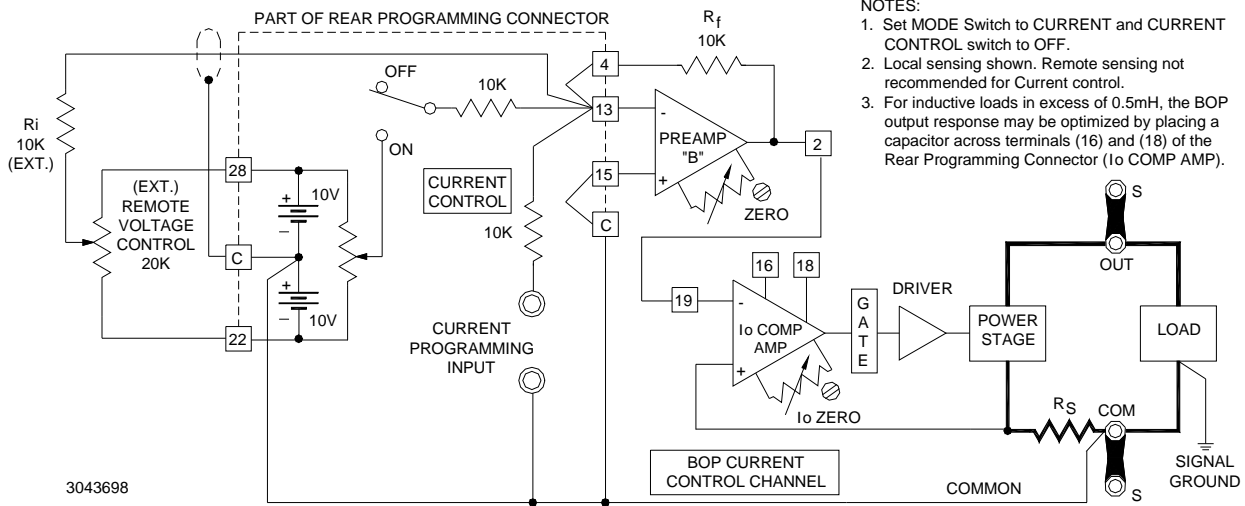

FIGURE 3-14. REMOTE POTENTIOMETER CONTROL OF THE BOP OUTPUT CURRENT

3.5.2 REMOTE CURRENT CONTROL USING RESISTANCE (DECADE BOX)

See Figure 3-15 for remote current control using a two-terminal resistance (decade box)

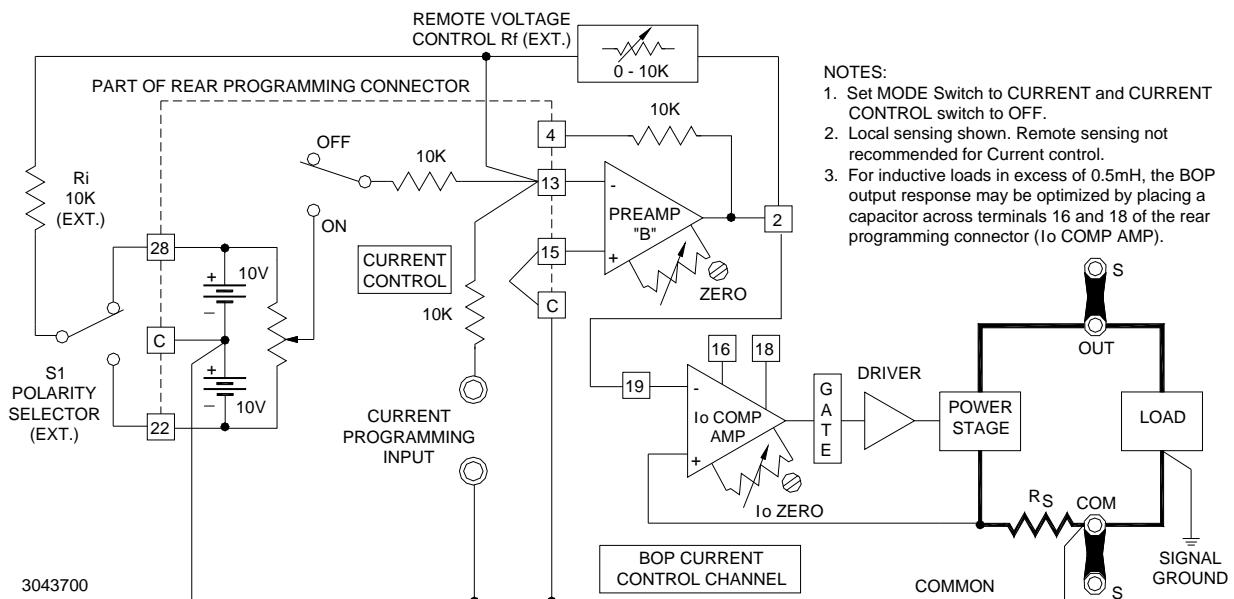
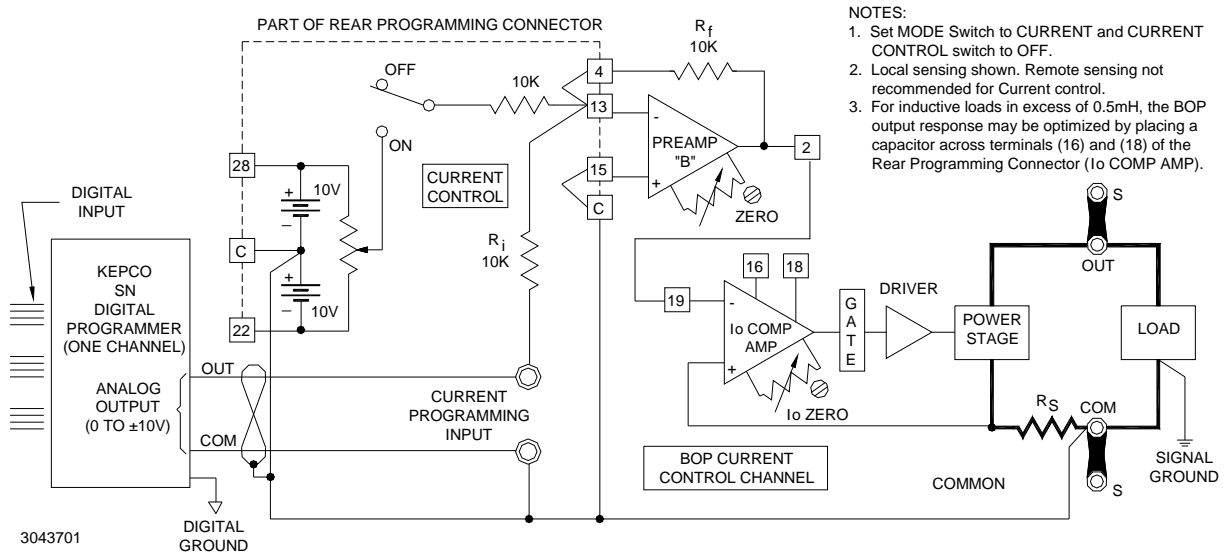

FIGURE 3-15. REMOTE D-C OUTPUT CURRENT CONTROL USING TWO-TERMINAL RESISTANCE (DECADE)

3.5.3 REMOTE CURRENT CONTROL USING D-C SIGNAL VOLTAGE

See Figure 3-16 for remote current control using a d-c signal voltage.

See Figure 3-17 for remote current control using a high impedance $\pm 1V$ voltage. Preamplifier "B" is used in the non-inverting configuration, so the output current will have the same polarity as the input programming signal.



NOTES:

1. Set MODE Switch to CURRENT and CURRENT CONTROL switch to OFF.
2. Local sensing shown. Remote sensing not recommended for Current control.
3. For inductive loads in excess of 0.5mH, the BOP output response may be optimized by placing a capacitor across terminals (16) and (18) of the Rear Programming Connector (Io COMP AMP).

FIGURE 3-16. DIGITAL CONTROL OF OUTPUT CURRENT

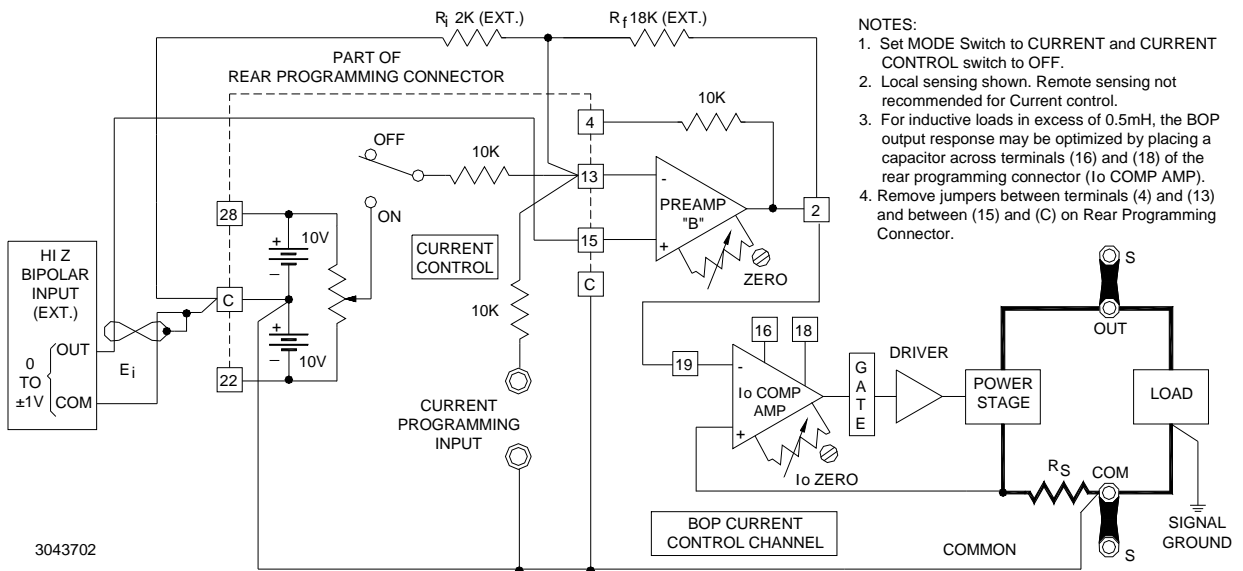

NOTES:

1. Set MODE Switch to CURRENT and CURRENT CONTROL switch to OFF.
2. Local sensing shown. Remote sensing not recommended for Current control.
3. For inductive loads in excess of 0.5mH, the BOP output response may be optimized by placing a capacitor across terminals (16) and (18) of the rear programming connector (Io COMP AMP).
4. Remove jumpers between terminals (4) and (13) and between (15) and (C) on Rear Programming Connector.

FIGURE 3-17. BOP OUTPUT CURRENT CONTROL WITH NON-INVERTING CONFIGURATION AND HIGH IMPEDANCE (± 1) VOLT SIGNAL SOURCE

3.5.4 USING THE BOP AS A CURRENT AMPLIFIER

See Figure 3-18 to configure the BOP as a current-stabilized bipolar amplifier.

See Figure 3-19 to drive output current using a bipolar signal voltage less than $\pm 10V$.

See Figure 3-20 to drive output current using a high impedance source.

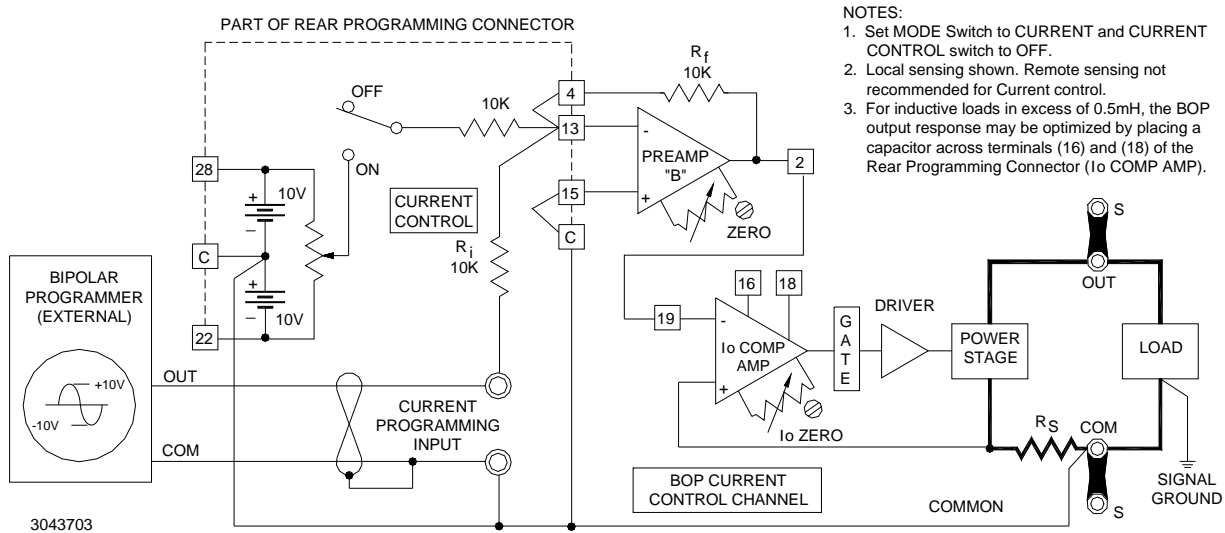

FIGURE 3-18. BASIC PROGRAMMING CIRCUIT FOR BOP AS BIPOLAR CURRENT-STABILIZED AMPLIFIER

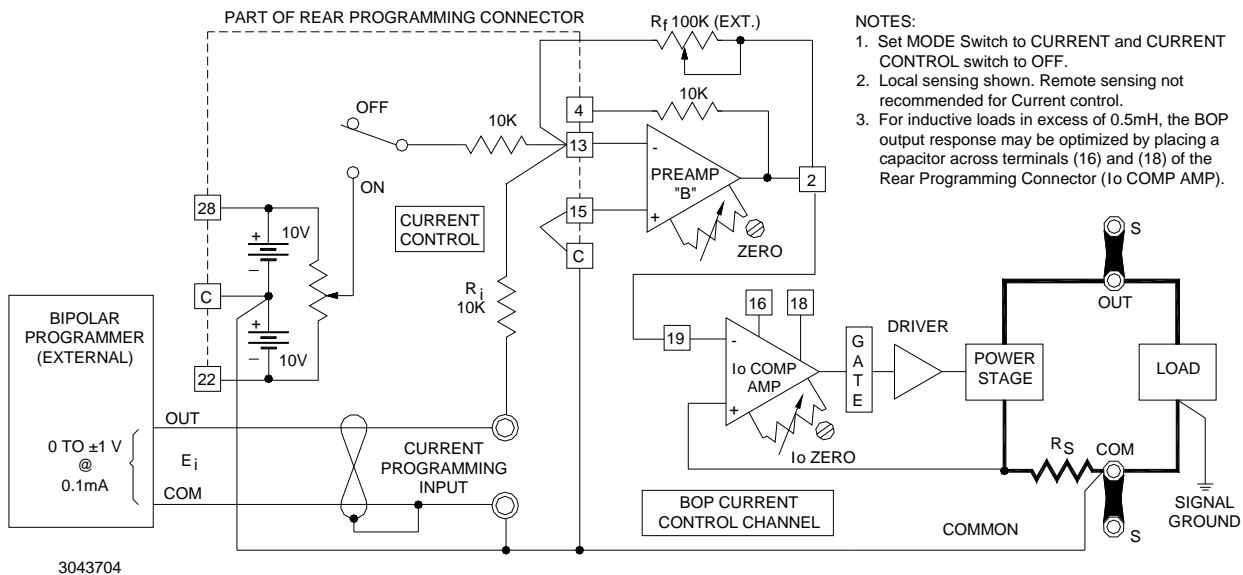

FIGURE 3-19. PROGRAMMING CIRCUIT FOR DRIVING OUTPUT CURRENT WITH BIPOLAR SIGNAL LESS THAN $\pm 10V$

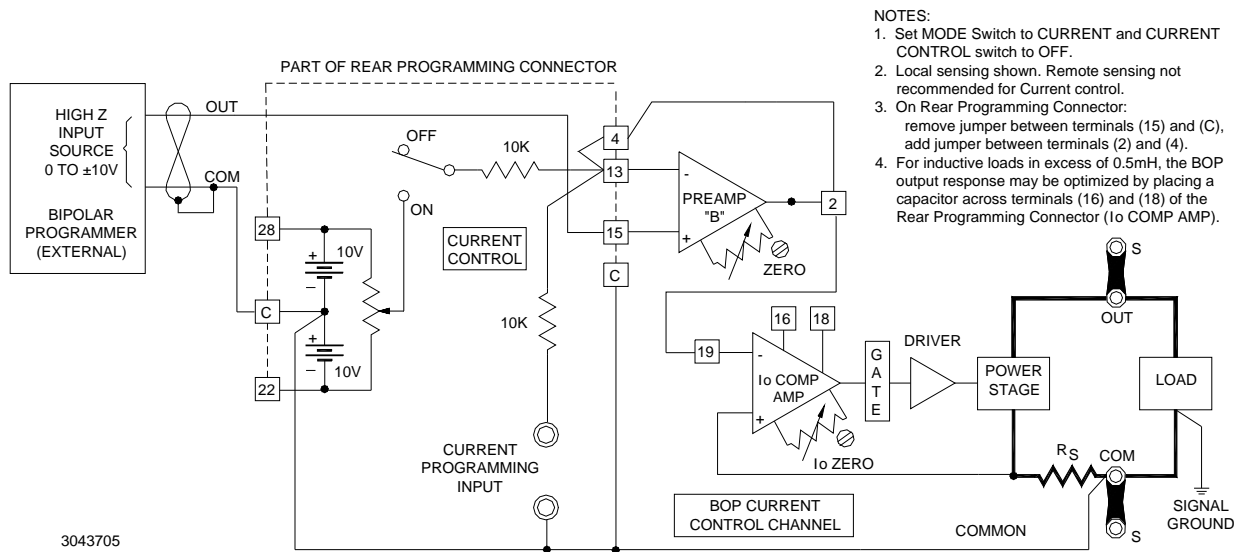

FIGURE 3-20. PROGRAMMING CIRCUIT FOR DRIVING OUTPUT CURRENT WITH A HIGH IMPEDANCE SOURCE

3.5.5 REMOTE CONTROL OF VOLTAGE LIMITING

The E_O Limit circuit can be configured to use a single external 0 to 10V d-c programming source to symmetrically control \pm Voltage Limits as shown in Figure 3-21. The circuit functions in a manner similar to the I_O Limit circuit (refer to Paragraph 3.4.5), except that the voltage limit feedback is derived by means of a voltage divider across the BOP output.

The + and - voltage limit can be controlled independently by individual 0 to 10V d-c sources, as illustrated in Figure 3-22.

NOTE: The front panel $\pm E_O$ LIMIT controls serve as a back-up when external voltage limit programming is used. The front panel VOLTAGE LIMIT CONTROLS should be set to their maximum positions if full range remote control of the BOP voltage limit is desired. For both local and remote control the voltage limit range is between 1% and 110% of the nominal voltage value.

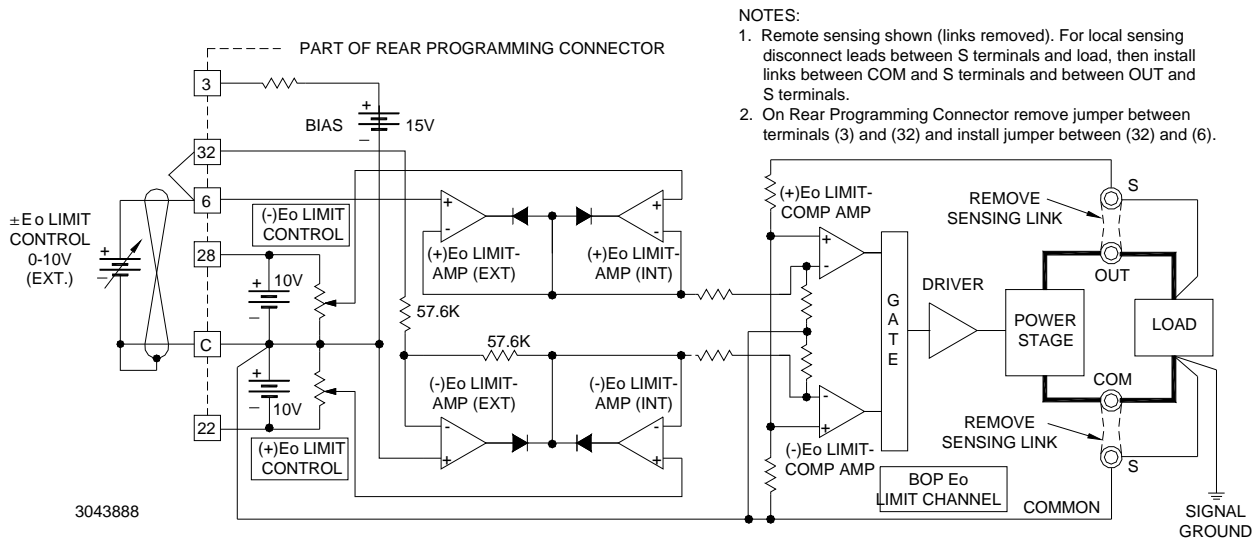

FIGURE 3-21. SYMMETRICAL REMOTE CONTROL OF VOLTAGE LIMIT

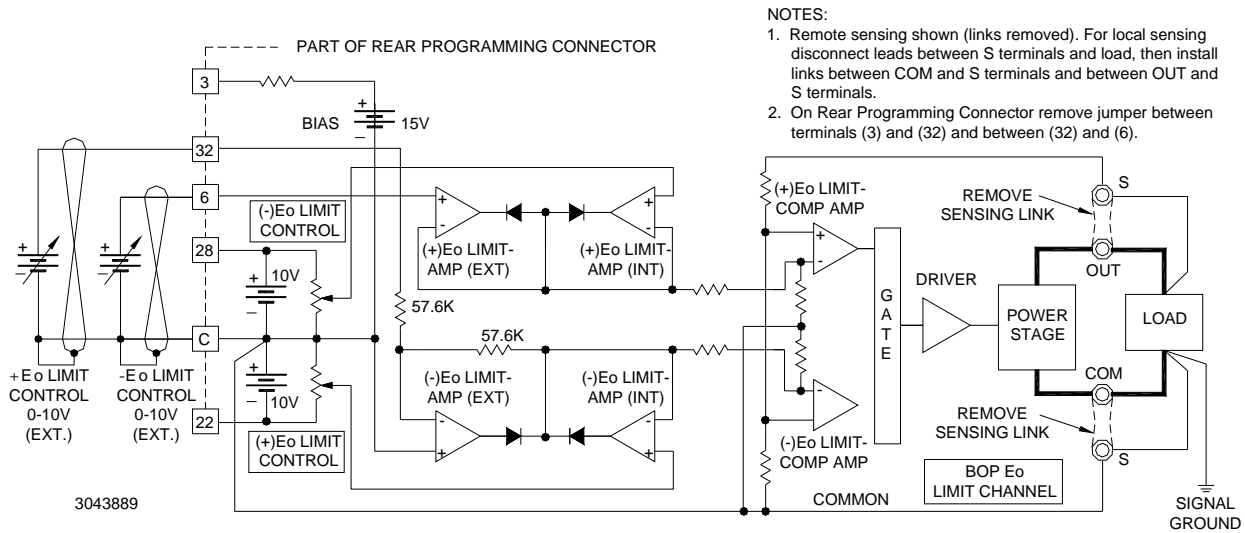

FIGURE 3-22. INDEPENDENT REMOTE CONTROL OF +E₀ AND -E₀ VOLTAGE LIMIT

3.6 SERIES AND PARALLEL CONNECTION OF BOP POWER SUPPLIES.

Voltage sources, such as batteries, cells or stabilized d-c power supplies can be readily series-connected, but normally they can not be paralleled. Even minute differences in their terminal potential would cause large, damaging, circulating currents. By complementary reasoning, current sources can easily be paralleled, but not series-connected. Fortunately, with practical stabilized power supplies these difficulties can be overcome in various ways.

There are two basic methods which are commonly used for the series or parallel connection of stabilized d-c power supplies. The first method is the “Automatic” series or parallel connection by which the power supply outputs are simply connected together, in series or parallel, as required. The individual supplies can now be adjusted to the load requirements. The “Automatic” method presents no problems as long as it is confined to series connection with voltage sources, or to parallel connection with current sources. As far as the BOP is concerned, the only thing to remember is to place the MODE switch into its proper position:

- Auto-series connection: MODE switches of all BOP to VOLTAGE
- Auto-parallel connection: MODE switches of all BOP to CURRENT

The second method for series or parallel connection of two or more units is the “Master/Slave” configuration, by which a designated Master supply controls the output of one or more Slave units. This control method permits control of the common output by a single unit - the MASTER. Since this method presents the least problems for either series or parallel connections and since it is readily implemented with BOP power supplies, it is the recommended method for this kind of operation and is described below.

3.6.1 SERIES CONNECTION, MASTER/SLAVE OPERATION

Two or more BOP power supplies can be connected in series to increase output voltage. One series-connection limitation is the isolation limit of the BOP itself (500V); contact Kepco if more than three units in series are required. Figure 3-23 shows a master/slave connection of two BOP power supplies.

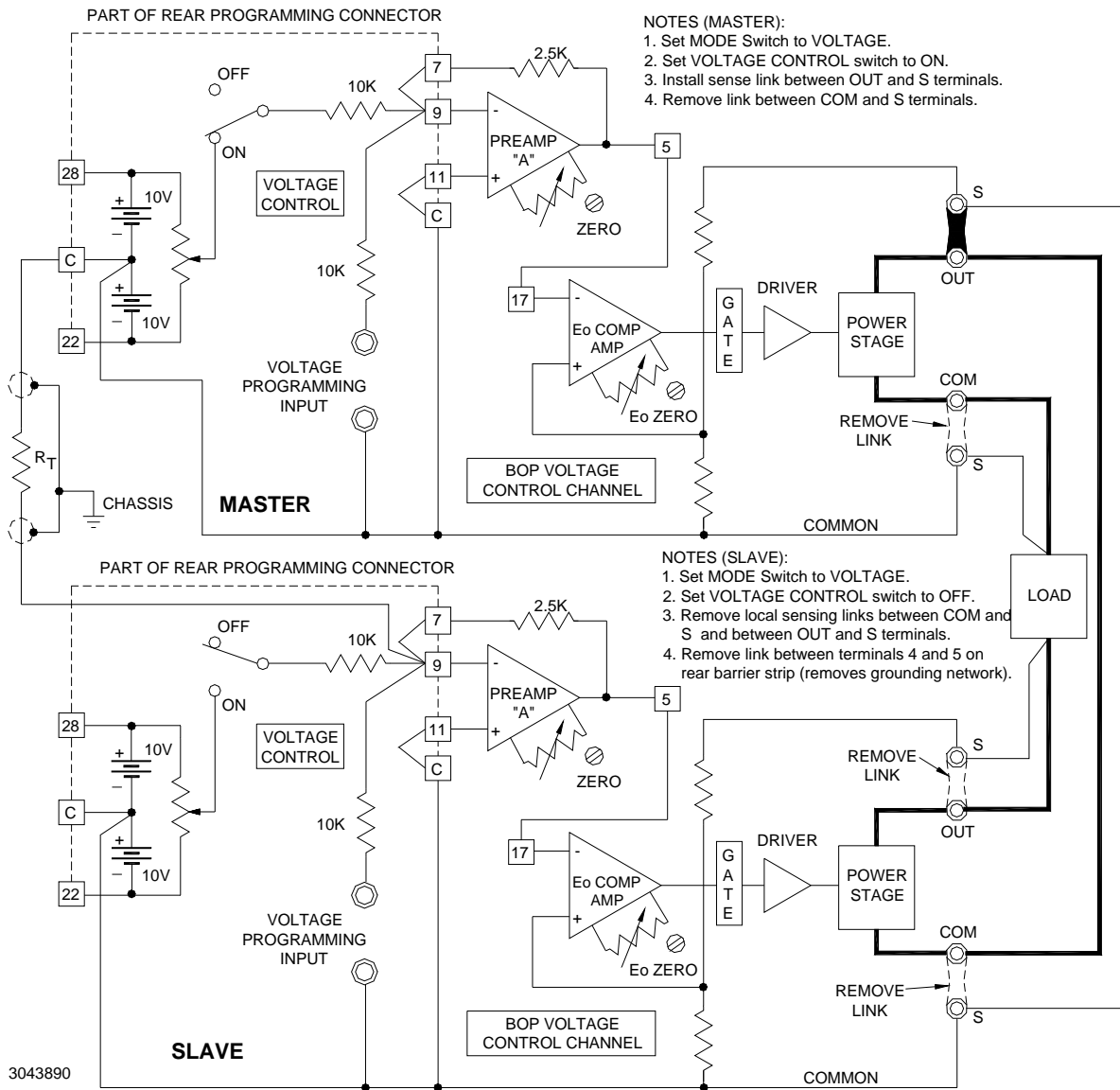

FIGURE 3-23. SERIES CONNECTION (MASTER/SLAVE) OF TWO BOP POWER SUPPLIES, WITH REMOTE ERROR SENSING AT THE COMMON LOAD

To extend the concept of series connection to more than two BOP units, refer to FIG. 3-23. The BOP unit now designated the SLAVE becomes the new MASTER for the next BOP unit to be added and so on, up to the desired number of BOP's in series. Simply place the BOP outputs in series and connect a further coupling resistor (R_T) from the present SLAVE, terminal [C] to the new SLAVE, front panel VOLTAGE PROGRAMMING INPUT. Place the MODE switch on the BOP added to the series combination to VOLTAGE and the VOLTAGE CONTROL switch OFF.

1. Connect the BOP supplies as shown in Figure 3-23. Set the MODE switches and the VOLTAGE CONTROL switches as directed in the set-up diagram, Figure 3-23.

- a. Load-wire size should be rated to at least the maximum load current and load-wire pairs should be twisted or tied together to keep the inductance and EMI as low as possible. For remote sensing, use #22 AWG twisted pair wires.
 - b. Use shielded cable for connecting the coupling resistor (R_T). Connect shield to chassis-ground. Either the positive or the negative output side of the system can be grounded.
 - c. The coupling resistor (R_T) should be either a wirewound or a metal film component with a low temperature coefficient. For both BOP 5-20DL and BOP 5-30DL this value is 5K (either 1/4 or 1/2 Watt). This value of R_T will be able to drive the BOP Slave unit to its (\pm) maximum output voltage as the BOP Master is controlled through its range.
 - d. Both BOP power supplies should be connected to the power line using a common circuit breaker. Alternatively, the BOP Circuit Breaker Control Circuit, as described in PAR. 3.6.2, can be used to interconnect both BOP's in such a way that if one of them should fail, the other one is automatically shut down also.
2. Turn BOP's on and begin operation. The system as shown in Figure 3-23 operates in Voltage Mode, since the Master MODE switch is in VOLTAGE position. For operation in Current Mode, transfer the Master MODE switch to CURRENT.

3.6.2 CIRCUIT BREAKER CONTROL CIRCUIT

The BOP is protected by the dual-coil circuit breaker/ON-OFF switch (CB101) as shown in Figure 3-24. The current sensing coil of CB101 is connected in series with the primary winding of T201, thus detecting overcurrent reflected into the primary circuit and subsequently tripping the circuit breaker. The voltage sensing coil of CB101 is connected in series with an SCR (CR4) across the driver collector supply. If the SCR is triggered on, the voltage sensing coil is energized and trips the circuit breaker. The SCR (CR4) can be triggered in several ways:

- On a-c line power loss or interruption, Q1 will lose its turn-on bias first, due to the small time-constant provided in its base circuit (not shown in the simplified block diagram). As a result, Q2 is turned on, energizing the diode in the optical isolator (LC-1) and providing a turn-on signal for the SCR (CR4).
- In the event of an excessive heat rise on the power stage assembly, the thermal switch (S401) will close, energizing the diode in the optical isolator (LC-1) and providing thus the turn-on signal for the SCR (CR4).
- An input signal applied across terminals 49 (+) and 47 (–) of the Rear Programming Connector energizes the diode in the second optical isolator (LC-2) which, in turn, energizes the diode in the first optical isolator (LC-1), thus providing for SCR turn-on.

NOTE: Upon turn-off, an isolated output signal is available at Rear Programming Connector terminals 26 (+) and 36 (–). This output signal can be used to turn off other equipment when the BOP is turned off. As an example, applying it across terminals 49 and 47 of the Rear Programming Connector of a second BOP allows the master of a parallel or series configuration to turn off the slave when the master is turned off.

- A manual, non-isolated turn-off is provided which, when implemented with an external switch contact as shown in Figure 3-24, will energize the diode in the first optocoupler (LC-1). thus providing the SCR turn-on.

- If it is not desired to trip the circuit breaker (CB101) upon a-c line power loss, it can be prevented by a jumper wire or an external switch across terminals 24 and 25 on the Rear Programming Connector. In this manner, Q1 is inhibited from providing a turn-on signal for Q2, thus avoiding triggering the SCR and tripping the circuit breaker.

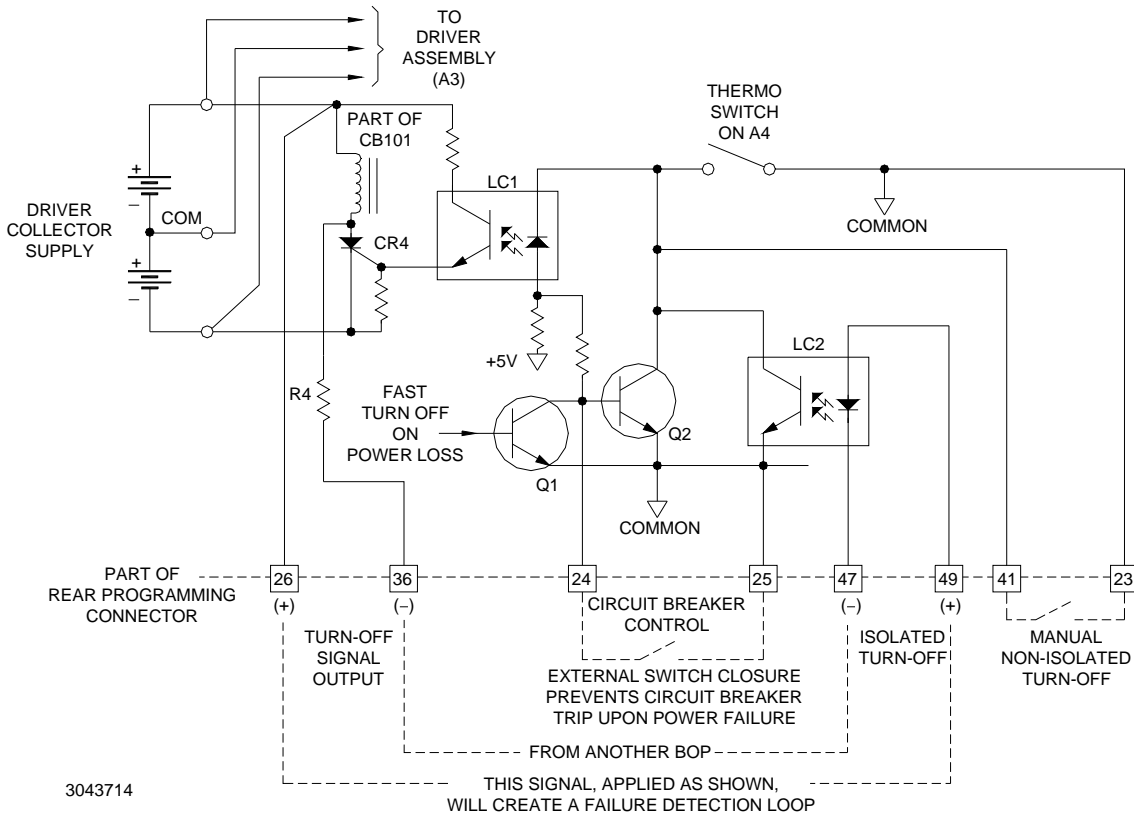

FIGURE 3-24. CIRCUIT BREAKER CONTROL CIRCUIT, SIMPLIFIED DIAGRAM.

3.6.3 PARALLEL CONNECTION, MASTER/SLAVE OPERATION

BOP power supplies can be connected in parallel to increase output current. One parallel-connection limitation is the load-wire size required for larger output current. Contact Kepco if more than three units in parallel are required.

Figure 3-25 shows a simple parallel master/slave connection of no more than two BOP power supplies. The configuration shown in Figure 3-26 is more stable and accurate than that shown in Figure 3-25 since it includes compensation that eliminates the parasitic voltage drop on the COM connections of the slaves. The slave's preamplifier B is configured as a differential amplifier for the master's output current monitoring signal. Figure 3-26 is recommended for more than two units in parallel or where greater precision and stability is desired.

1. Connect the BOP supplies as shown in Figure 3-25 or 3-26 (see above for details).
 - a. Set the MODE switches and the VOLTAGE and CURRENT CONTROL switches as directed in the set-up diagram, Figure 3-25 or 3-26.

- b. Load-wire size should be rated for at least the maximum load current and load-wire pairs should be twisted or tied together to keep the inductance and EMI as low as possible. Use shielded cable for the drive signal connection between the BOP's. Connect the shield to common ground. For remote sensing, use #22 AWG twisted pair wires.
- c. Both BOP power supplies should be connected to the power line using a common circuit breaker. Alternatively, the BOP Circuit-Breaker Control Circuit, as described in PAR. 3.6.2 can be used to interconnect both BOPS in such a way, that if one of them should fail, the other one is automatically shut down also.
2. Following the set-up procedure as described above, turn BOP's on and commence operation. The system as shown in the set-up diagram, Figure 3-25 or 3-26, operates in the Voltage Mode, since the MASTER MODE switch is set to VOLTAGE. For operation in the current mode, set the MASTER MODE switch to CURRENT.

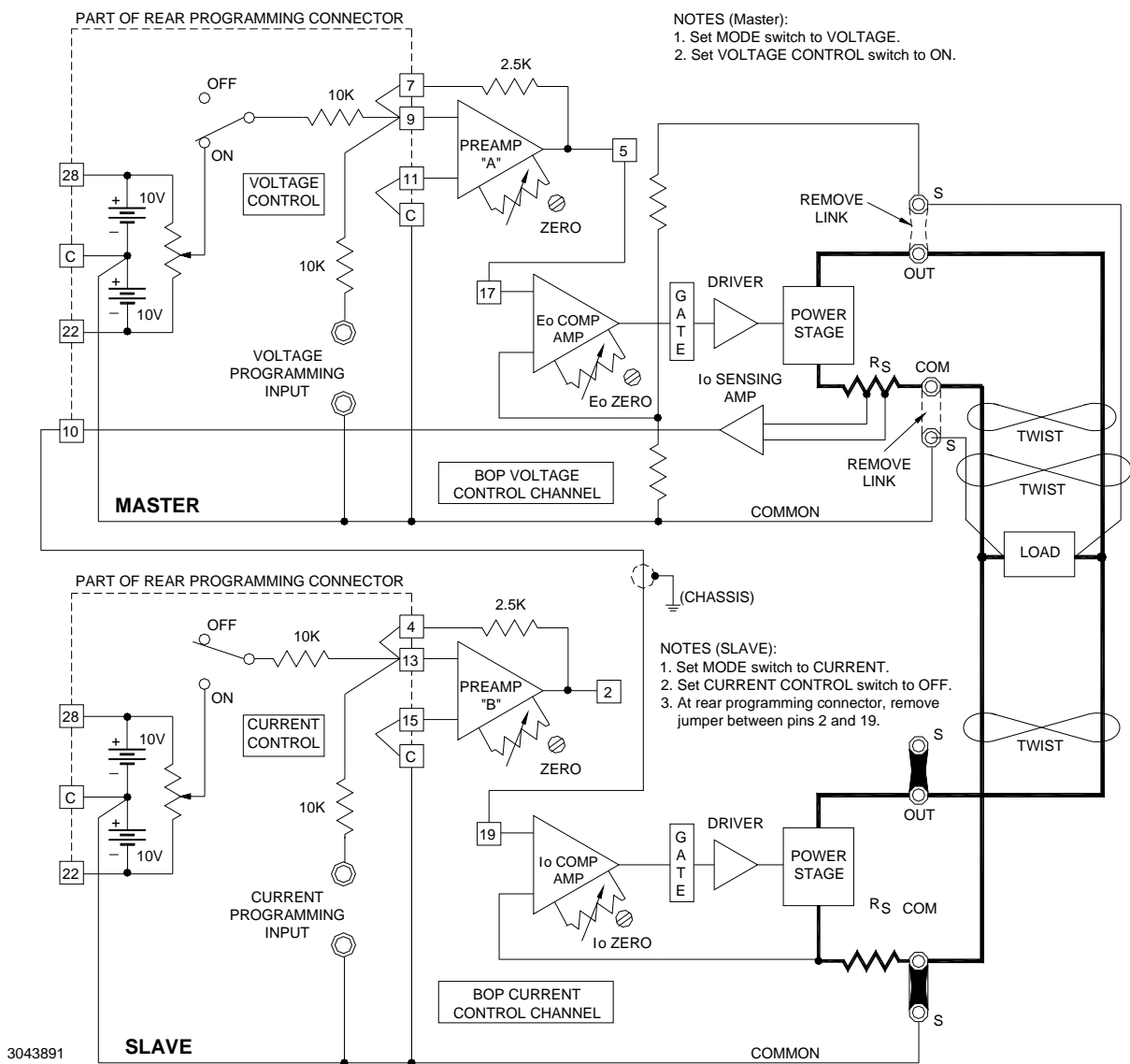

FIGURE 3-25. PARALLEL CONNECTION (MASTER/SLAVE) OF TWO BOP POWER SUPPLIES WITH REMOTE ERROR SENSING AT THE COMMON LOAD

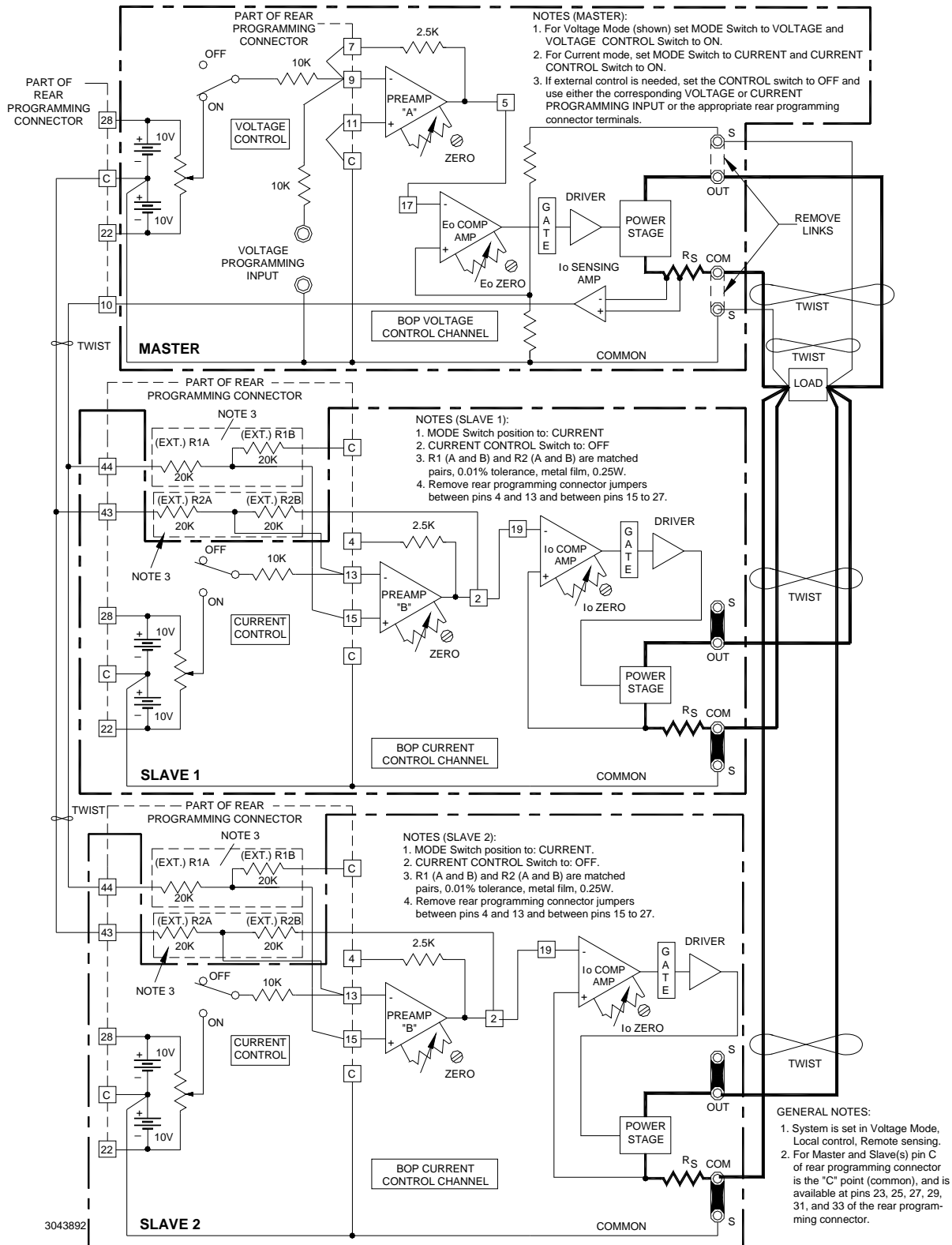

FIGURE 3-26. ALTERNATIVE PARALLEL CONNECTION (MASTER/SLAVE) FOR GREATER PRECISION AND STABILITY OF TWO OR MORE BOP POWER SUPPLIES

3.7 INDICATOR AND FLAG LOGIC CIRCUIT

Digital Logic Circuits (IC15, IC16, IC17) as shown in Figure 3-27 are used in the BOP to drive the front panel LEDs which indicate the prevailing operating mode:

- E_O LIMIT MODE (DS101)
- I_O LIMIT MODE (DS102)
- E_O MODE (DS103)
- I_O MODE (DS104)
- REMOTE (DS105)

Together with these visual front panel indicators, TTL-compatible status flags are provided at the Rear Programming Connector for the above BOP operating modes. All status flags available on the rear programming connector indicate a logic "0" if the BOP is operating in the indicated operating mode, and a logic "1" if it is not.

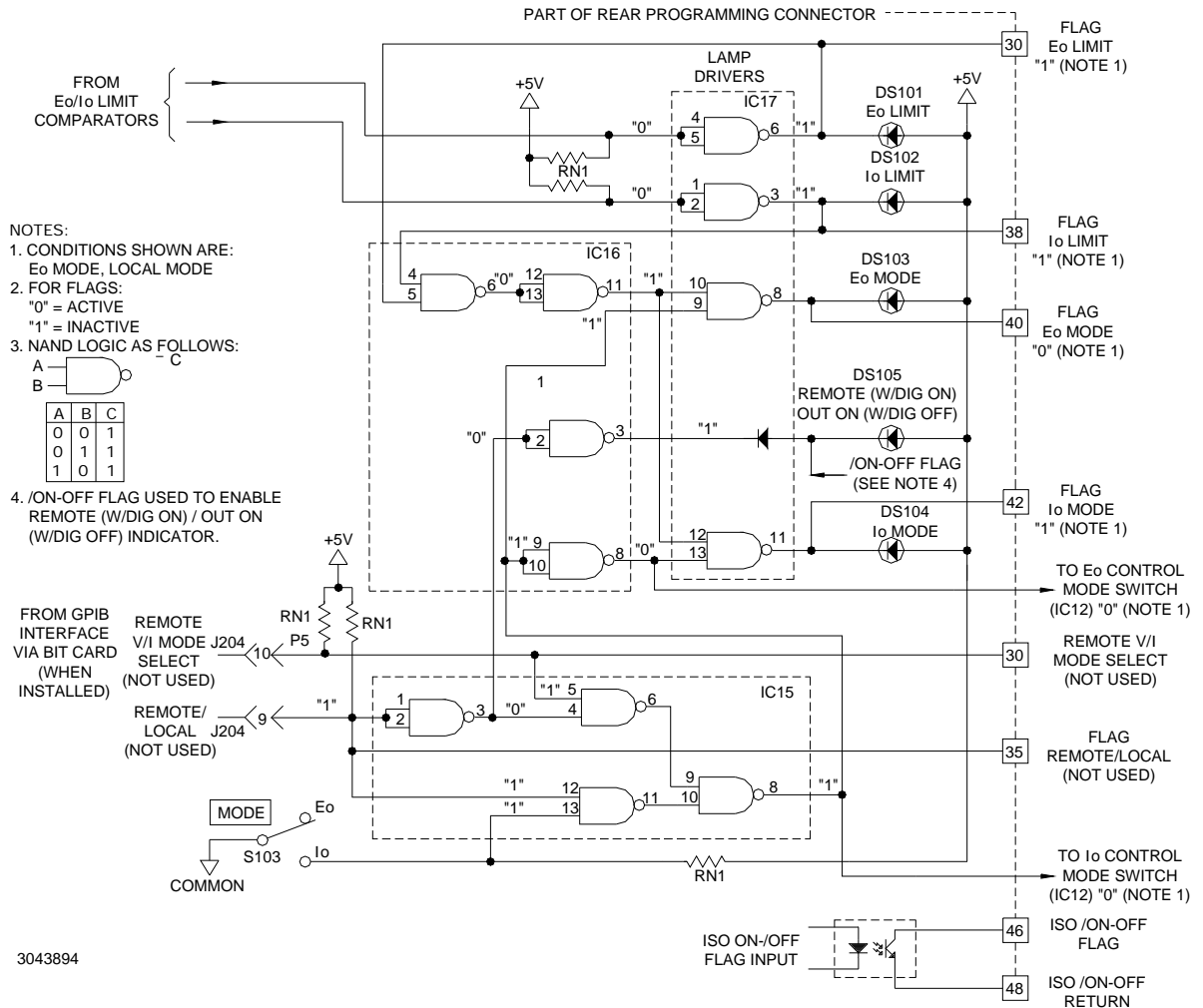

FIGURE 3-27. INDICATOR LIGHT AND FLAG LOGIC

The logic status signals shown in Figure 3-27 are valid for the BOP operating in voltage mode (E_O MODE) and local mode (not driven by the GPIB interface). The front panel REMOTE (W/DIG ON)/OUT ON (W/DIG OFF) indicator shows the output on-off status as determined by signals applied to the isolated OUTPUT ON-OFF control or to the non-isolated ON-OFF input control

3.8 DIGITAL CONTROL OF BOP POWER SUPPLIES.

The BOP is configured with a remote output ON-OFF PORT which interfaces electrically and mechanically with the digital control assembly used by a BIT Interface card which must be installed for digital control. If digital control is required, contact Kepco to order the proper BIT interface card and associated installation instructions. Digital control options available are via either GPIB and RS 232 using a BIT 4886 Interface Card, or ethernet/LAN using a BIT 802E Interface card. Both cards are compliant with IEEE 488 and SCPI commands and queries. For more details, see www.kepcopower.com/bit.htm.

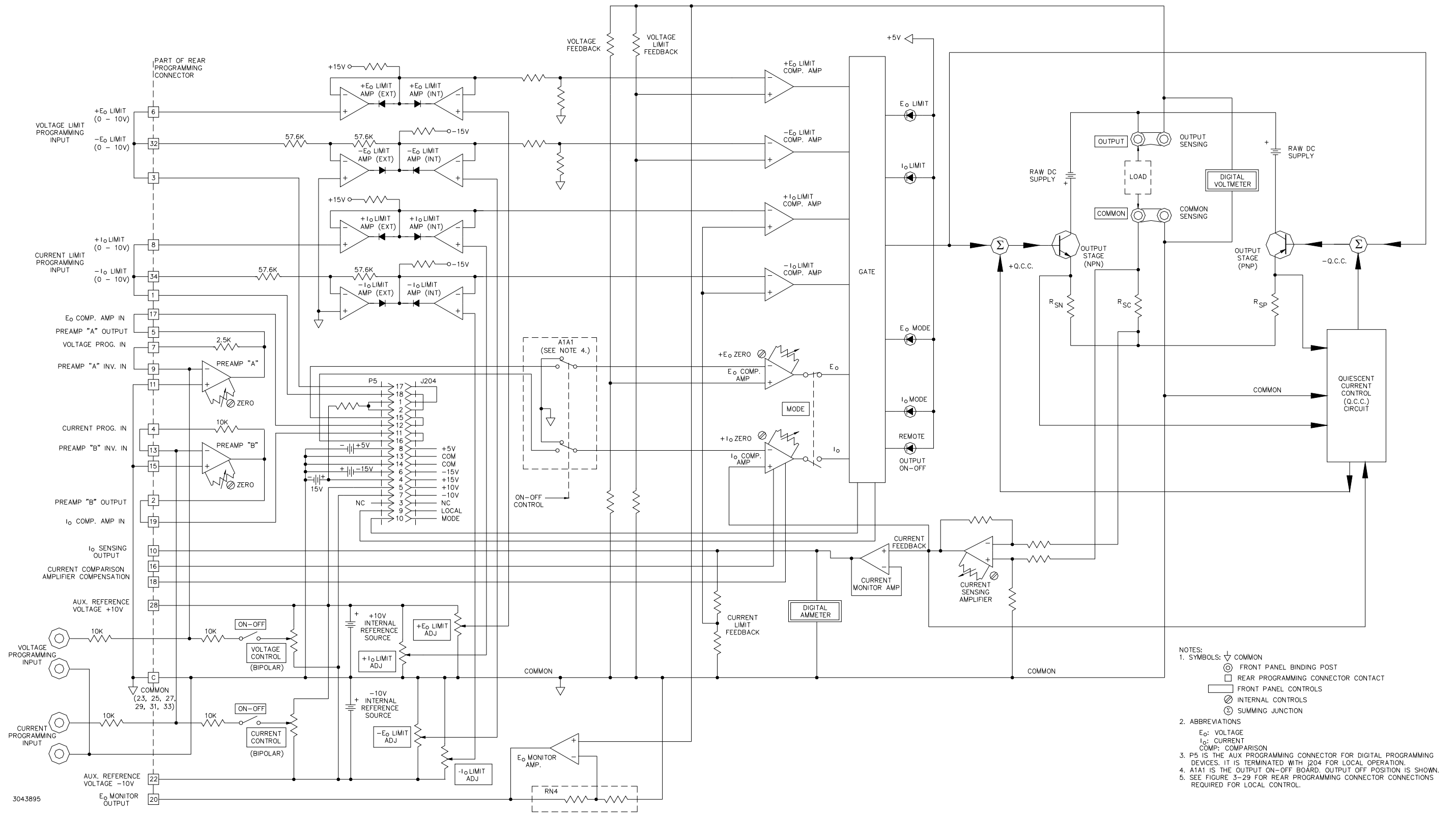
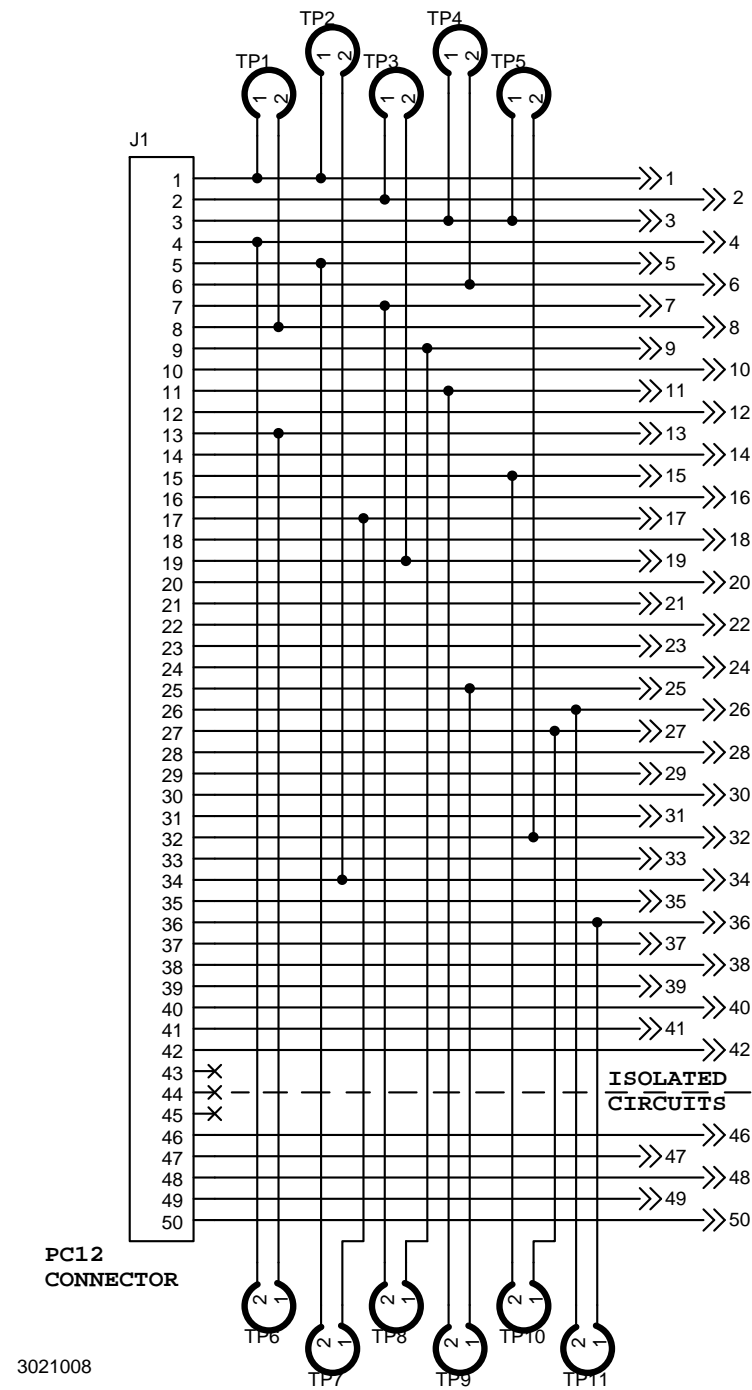

FIGURE 3-28. SIMPLIFIED SCHEMATIC DIAGRAM, BOP 5-20DL, BOP 5-30DL



NOTES:

1. Connectors 195-0039 and 195-0121 both perform the same function. Connections shown are for PC 15, local control.

2. For P/N 195-0039, wires are added directly to the terminals for local control. User-added wires or components are connected directly to the terminals.

3. For P/N 195-0121 connections are made via the PWB traces and test points installed at the factory. The following table lists the pins connected when the test points are installed. For complete PWB connections, refer to the schematic diagram at the left.

TEST POINT	PINS CONNECTED WHEN TEST POINT INSTALLED	
	PIN 1	PIN 8
TP1	PIN 1	PIN 8
TP2	PIN 1	PIN 34
TP3	PIN 2	PIN 19
TP4	PIN 3	PIN 6
TP5	PIN 3	PIN 32
TP6	PIN 4	PIN 13
TP7	PIN 5	PIN 17
TP8	PIN 7	PIN 9
TP9	PIN 11	PIN 25
TP10	PIN 15	PIN 27
TP11	PIN 26	PIN 36

4. For P/N 195-0121 if necessary to isolate any pins connected by a test point, cut the test point. **CAUTION: Improper soldering technique may damage the PWB beyond repair.** Holes are provided at the test points for user-added wires or components. In addition, three holes per pin are provided on the PWB for user-added wires or components.

5. PC 12 (unwired) is supplied either without wires or without test points, depending on the connector used.

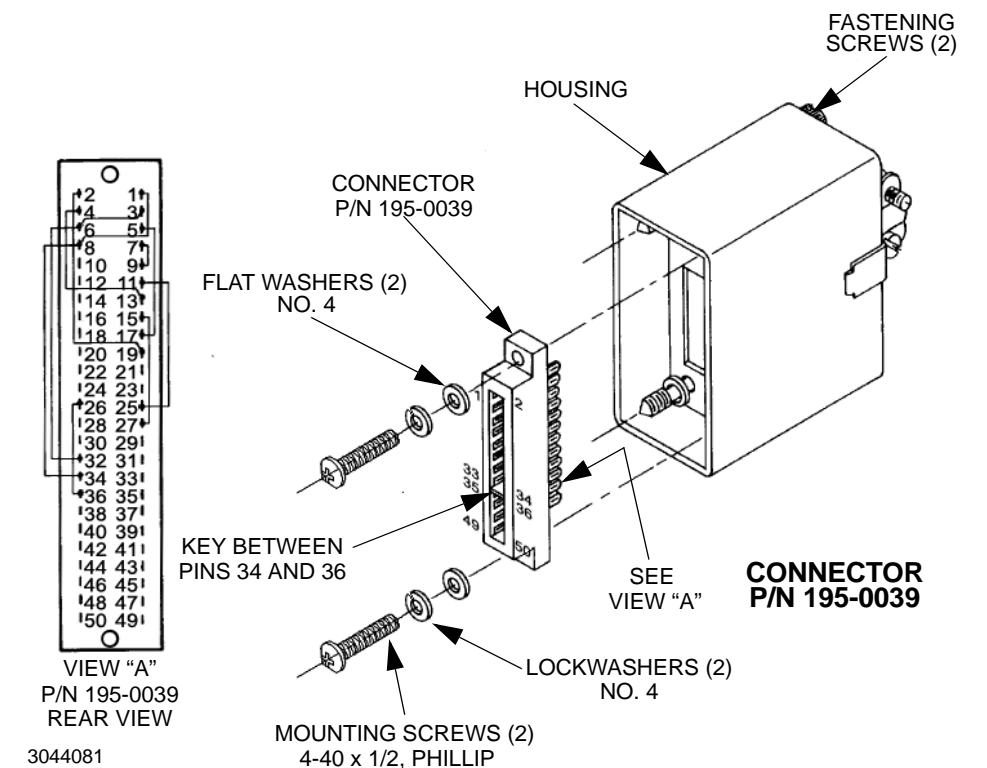
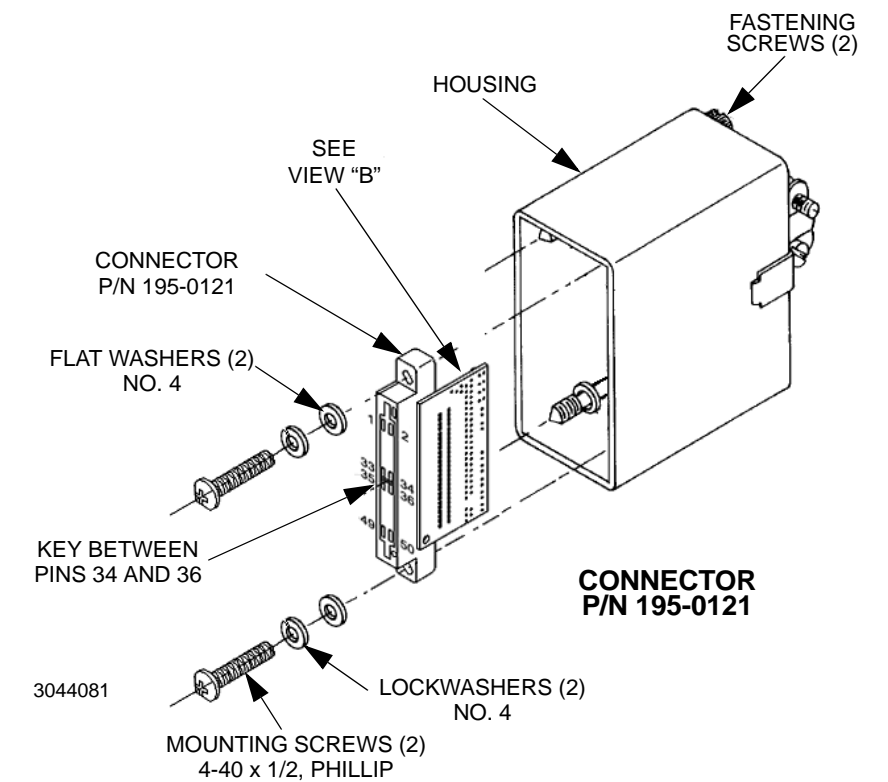
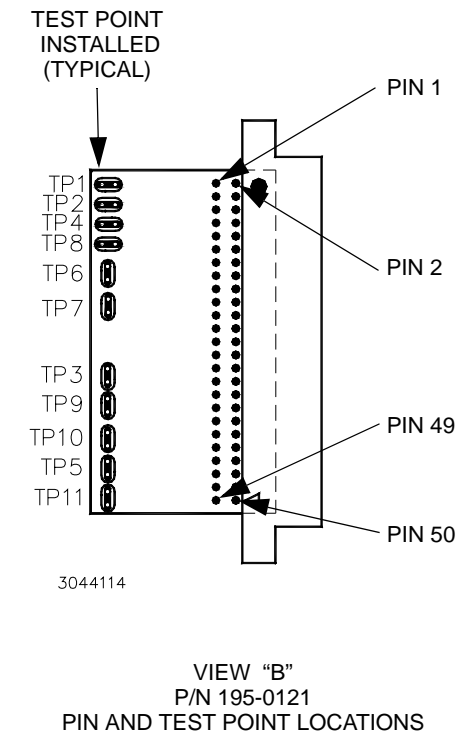

Figure 3-29. PC 15/PC 12 Rear Programming Connector Interconnections

SECTION 4 - INTERNAL ADJUSTMENTS AND CALIBRATION

4.1 GENERAL

This section contains the procedures for all internal adjustments and calibrations.

All internal adjustment controls are illustrated In Figure 4-1 and listed in Table 4-1. Table 4-1 explains the purpose of each control and references the applicable adjustment procedure.

NOTE: These controls are factory calibrated. Re-calibration is necessary only if components, related to the circuitry involving these controls have to be replaced.

TABLE 4-1. INTERNAL CALIBRATION CONTROLS

REFERENCE DESIGNATION (SEE FIGURE 4-1)	CONTROL NAME	PURPOSE	ADJUSTMENT PROCEDURE
A1R31, A1R32	±10V CAL.	Reference Voltage Calibration	PAR. 4.2.1
A1R41	PREAMP 'A' ZERO	Uncommitted Amplifier "A" Zero Adjustment	PAR. 4.2.2
A1R42	PREAMP 'B' ZERO	Uncommitted Amplifier "B" Zero Adjustment	PAR. 4.2.3
A1R50	AMMETER ZERO	Sensing Amp. Offset Adjustment	PAR. 4.2.4
A1R81 ⁽¹⁾	E _o COMP AMP ZERO	Voltage Channel Zero Adjustment	PAR. 4.2.6
A1R83 ⁽¹⁾	I _o COMP AMP ZERO	Current Channel Zero Adjustment	PAR. 4.2.7
A3R316 ⁽¹⁾	I _o CAL	Full Scale Output Current Calibration	PAR. 4.2.8
A1R133 ⁽²⁾	I _o OFF ZERO	Current Channel Zero Adjustment for OFF status	PAR. 4.2.5
A1R136 ⁽²⁾	E _o OFF ZERO	Voltage Channel Zero Adjustment for OFF status	PAR. 4.2.5
A7R3B ⁽¹⁾	I _o METER	Full Scale Ammeter Calibration	PAR. 4.2.8
NOTES: (1) Output ON (enabled) status must be applied at ON-OFF CONTROL for this adjustment. (2) Output OFF (disabled) status must be applied at ON-OFF CONTROL for this adjustment.			

4.2 EQUIPMENT REQUIRED

The following equipment is required to perform the adjustment procedures.

- Digital Voltmeter (DVM) with 6 digits resolution an at least 0.002% accuracy for d-c measurements.
- Precision Shunt Resistor

NOTE: • Because the voltage measured will be used as reference for calibration, the DVM used must be accurately calibrated prior to calibrating the BOP Power Supply.

- Proper cooling of the external precision shunt resistor ensures the accuracy of the calibration.

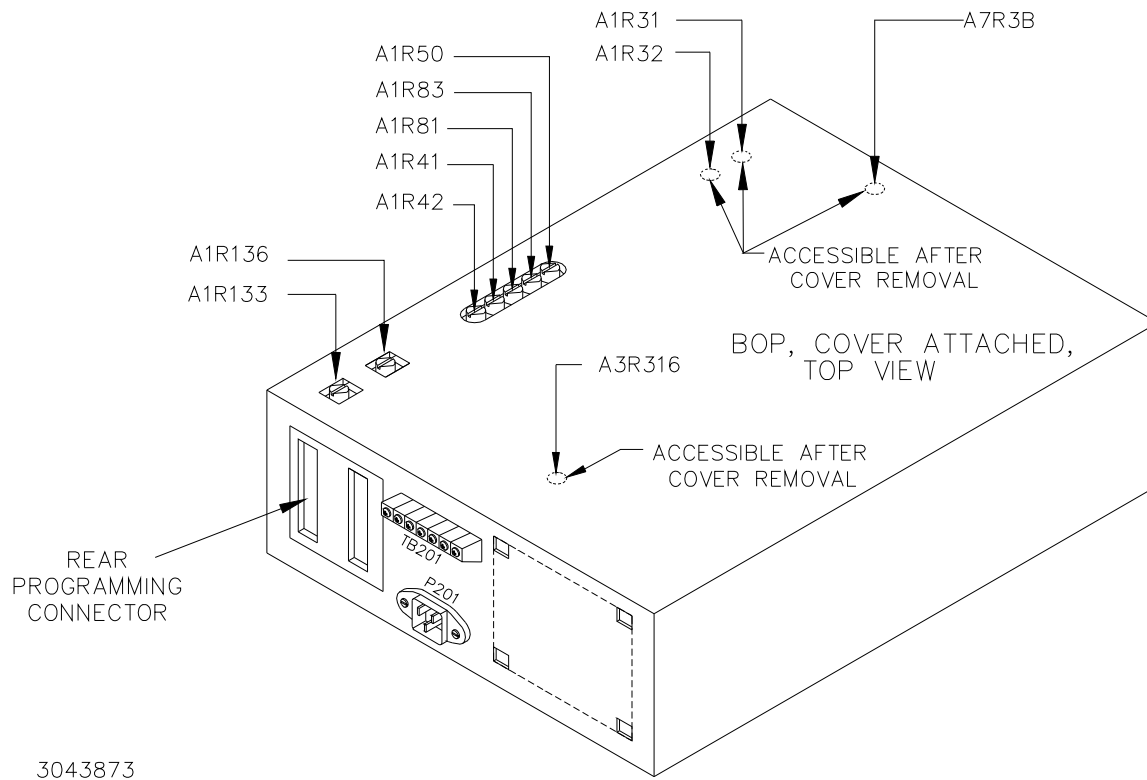

3043873

FIGURE 4-1. LOCATION OF INTERNAL CALIBRATION CONTROLS

4.2.1 ADJUSTMENT OF (\pm) 10 VOLT CALIBRATION CONTROLS (A1R31, A1R32)

1. Turn BOP off and remove the cover (see Figure 4-2).
2. Connect a precision digital voltmeter to the Rear Programming Connector terminal 28 (+10V) referenced to Common (terminal 23, 25, 27, 29, 31 or 33) for +10V adjustment.
3. Turn the BOP on and locate the +10V CAL control, A1R31 (see Figure 4-2).
4. Adjust control to +10V \pm 0.1mV as read on the digital voltmeter.
5. Connect a precision digital voltmeter (DVM) to terminal 22 (-10V) of the Rear Programming Connector referenced to Common (terminal 23, 25, 27, 29, 31 or 33) for -10V adjustment.
6. Adjust -10V CAL control, A1R32 (see Figure 4-2) to -10V \pm 0.1mV as read on DVM.

4.2.2 UNCOMMITTED AMPLIFIER “A” ZERO ADJUSTMENT (A1R41)

1. Without a load connected at the output, set MODE switch to VOLTAGE and VOLTAGE CONTROL switch to OFF.
2. Place a short circuit across the front panel VOLTAGE PROGRAMMING INPUT terminals.
3. Connect a Digital Voltmeter (DVM) to Rear Programming connector pin 5, referenced to pin 29 (signal common).
4. Locate the PREAMP “A” ZERO control (see Figure 4-2, A1R41), then turn the BOP on and adjust control for $0V \pm 0.1mV$, as read on DVM.

4.2.3 UNCOMMITTED AMPLIFIER “B” ZERO ADJUSTMENT (A1R42)

1. Without a load connected at the output, set MODE switch to VOLTAGE and VOLTAGE CONTROL switch to OFF.
2. Place a short circuit across the front panel CURRENT PROGRAMMING INPUT terminals.
3. Connect a Digital Voltmeter (DVM) to Rear Programming connector pin 2, referenced to pin 29 (signal common).
4. Locate the PREAMP “B” ZERO control (see Figure 4-2, A1R42), then turn the BOP on and adjust control for $0V \pm 0.1mV$, as read on DVM.

4.2.4 ADJUSTMENT OF AMMETER ZERO CONTROL (A1R50)

1. Without a load connected to the BOP output, and MODE switch set to VOLTAGE, connect a digital voltmeter (DVM) to the anode of A1CR29 referenced to Common (terminal 23, 25, 27, 29, 31 or 33 of the Rear Programming connector).
2. Turn the BOP on and locate the Ammeter Zero control (A1R50, Figure 4-2).
3. Adjust control to $0V \pm 0.1mV$ as read on DVM.

4.2.5 ADJUSTMENT OF I_O -OFF ZERO (A1R133) AND E_O -OFF ZERO (A1R136)

1. At rear panel, connect a wire jumper between terminals 21 and 23 of the Rear Programming connector to set the output to OFF (disabled).
2. Connect precision shunt resistor across the BOP OUTPUT and COMMON terminals. Connect DVM to the shunt's sensing terminals for output current measurements.
3. Set MODE switch to CURRENT and CURRENT CONTROL switch to OFF, then turn the BOP on.
4. Adjust I_O -OFF ZERO (A1R133) potentiometer (see Figure 4-2) for $0A \pm(0.01\% \text{ of } I_{O\text{nom}})$ as read on the DVM connected to the shunt. (For BOP 5-20DL $I_{O\text{nom}}$ is 20A and adjustment tolerance is $\pm 2\text{mA}$.; For BOP 5-30DL $I_{O\text{nom}}$ is 30A and adjustment tolerance is $\pm 3\text{mA}$.)
5. Turn off the BOP and remove the shunt resistor from the output. Connect the DVM to the output sensing terminal of the BOP (OUT S and COM S).
6. Set MODE switch to VOLTAGE and VOLTAGE CONTROL switch to OFF, then turn the BOP on.
7. Adjust E_O -OFF ZERO (A1R136) for $0V \pm(0.01\% \text{ of } E_{O\text{nom}})$ as read on DVM. (For BOP 5-20DL and BOP 5-30DL $E_{O\text{nom}}$ is 5V and adjustment tolerance is $\pm 0.5\text{mV}$.)

4.2.6 VOLTAGE CHANNEL ZERO ADJUSTMENT (A1R81)

1. At rear panel, remove the wire jumper between terminals 21 and 23 of the Rear Programming connector to set the output to ON (enabled).
2. Without a load connected at the output, set MODE switch to VOLTAGE and VOLTAGE CONTROL switch to OFF.
3. Place a short-circuit across front panel VOLTAGE PROGRAMMING INPUT terminals.
4. Connect DVM to the output sensing terminals, OUTPUT-SENSE and COMMON-SENSE.
5. Locate the E_O COMP AMP ZERO control (see Figure 4-2, A1R81), then turn on BOP and adjust the control for $0V \pm (0.005\% \text{ of } E_{O\text{nom}})$, as read on DVM. For BOP 5-20DL, $E_{O\text{nom}}$ is 5V and the tolerance range is $\pm 0.25\text{mV}$.

4.2.7 CURRENT CHANNEL ZERO ADJUSTMENT (A1R83)

1. At rear panel, remove the wire jumper between terminals 21 and 23 of the Rear Programming connector to set the output to ON (enabled).
2. With the unit turned off, connect a precision current measuring shunt, rated for the unit's nominal output current (20A for BOP 5-20DL, 30A for BOP 5-30DL) to the output.
3. Connect DVM to the shunt's sensing terminals.
4. Set MODE switch to CURRENT and CURRENT CONTROL switch to OFF.
5. Place a short circuit across the front panel CURRENT PROGRAMMING INPUT terminals.
6. Locate the I_O COMP AMP ZERO control (see Figure 4-2, A1R83), then turn on BOP and adjust control for 0A ±(0.005% of I_Onom), as read on DVM. For BOP 5-20DL, I_Onom is 20A and the tolerance range is ±1mA; for BOP 5-30DL, I_Onom is 30A and the tolerance range is ±1.5mA.

4.2.8 CALIBRATION OF I_O FULL SCALE OUTPUT CURRENT (A3R316)

1. Turn BOP off and remove the cover (see Figure 4-2).
2. Connect either a precision ammeter or a precision current-measuring shunt resistor to the output of the power supply. If a shunt is used, connect a DVM to the shunt's sensing terminals.
3. At rear panel, remove the wire jumper between terminals 21 and 23 of the Rear Programming connector to set the output to ON (enabled).
4. Set BOP MODE switch (6, Figure 2-1) to CURRENT mode operation.
5. Set BOP CURRENT control (8) switch to OFF.
6. Using the CURRENT PROGRAMMING INPUT terminals (11, Figure 2-1), program the unit by using an accurate and precise DC voltage source. Set DC programming source to +10V ±0.1mV for full scale output current.
7. Turn BOP power supply on.
8. Adjust A3R316 (see Figure 4-2 for location) until current reading displayed by ammeter or by the shunt's DVM exactly matches the BOP rated output current with 0.005% tolerance (-20A ±1mA for BOP 5-20DL, (-30A ±1.5mA for BOP 5-30DL). The current reading will show negative polarity due to the default inverting configuration of the unit.

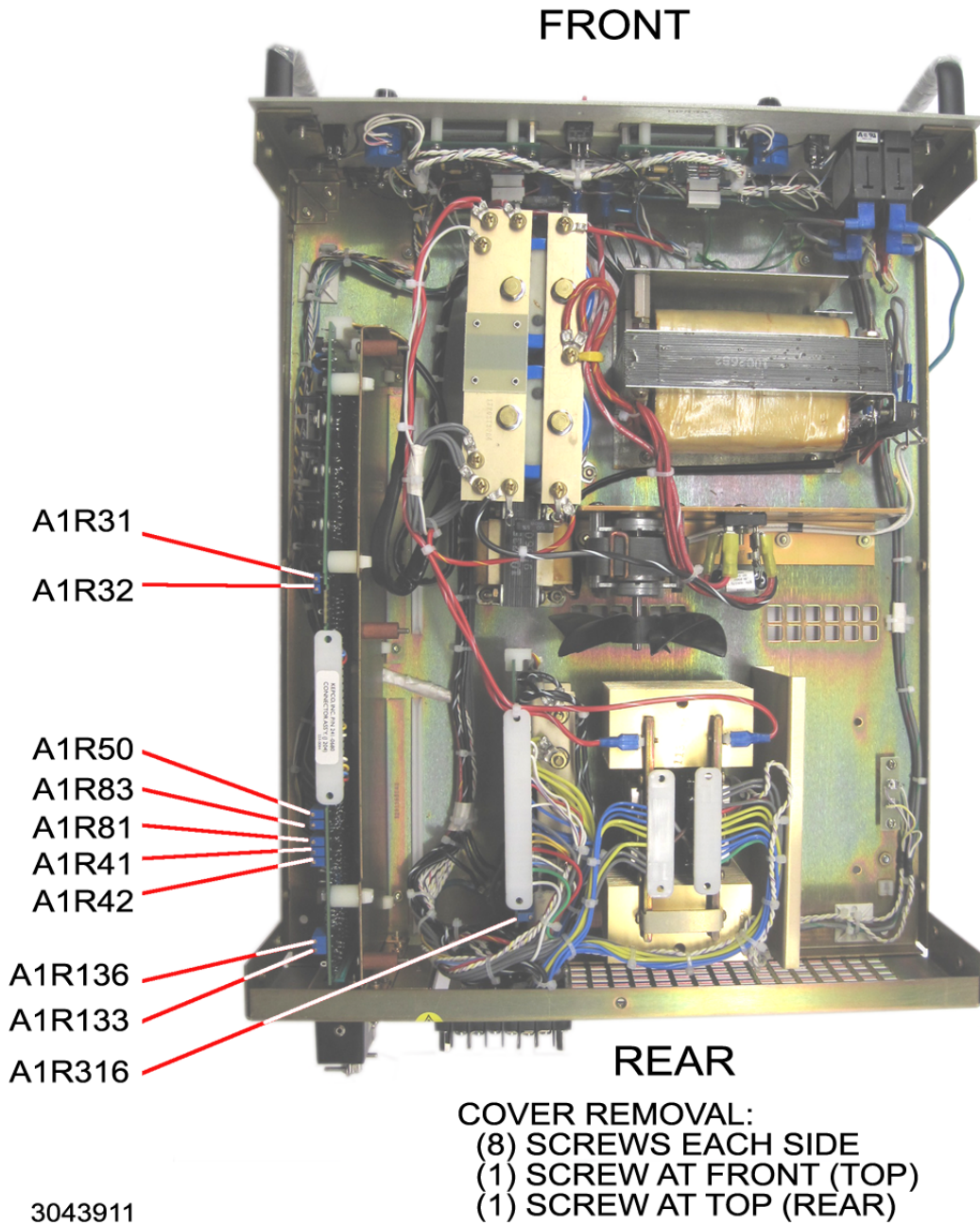

FIGURE 4-2. COVER REMOVAL AND INTERNAL COMPONENT LOCATIONS