

# OPERATOR'S MANUAL

## KLN 5KW, 10KW, 15KW PROGRAMMABLE D-C POWER SUPPLY EXTENDED RANGE

KEPCO INC.  
An ISO 9001 Company.



### IMPORTANT NOTES:

- 1) This manual is valid for the following Firmware Versions:

FIRMWARE VERSION	NOTE.
1.00.41 and higher	
- 2) A Change Page may be included at the end of the manual. All applicable changes and revision number changes are documented with reference to the equipment serial numbers. Before using this Instruction Manual, check your equipment firmware version number to identify your model. If in doubt, contact your nearest Kepco Representative, or the Kepco Documentation Office in New York, (718) 461-7000, requesting the correct revision for your particular model and firmware version number.
- 3) The contents of this manual are protected by copyright. Reproduction of any part can be made only with the specific written permission of Kepco, Inc.

Data subject to change without notice.

©2017, KEPCO, INC  
P/N 243-1369-draft





# OPERATOR SAFETY INSTRUCTIONS

Read these safety instructions, as well as the applicable installation and operating instructions contained in this manual before using the power supply. The safety approval of the KLN power supply series requires the following operating conditions: Indoor use, Ambient temperature: 0°C to 45°C, Maximum Relative Humidity: 80% (no condensation) and Altitude: Up to 2000m.



Do not touch the input terminals. The source a-c voltage is dangerous. Electric shock can cause injury or death.

Do not touch the output terminals. The output is dangerous. Electric shock can cause injury or death.

Do not remove the cover or disassemble the unit. There are no operator serviceable components or adjustments inside the unit. High voltage components inside the unit can cause serious injury even with input power disconnected.

Service must be referred to authorized personnel. Using the power supply in a manner not specified by Kepco. Inc. may impair the protection provided by the power supply. Observe all safety precautions noted throughout this manual. Table 1-6 lists symbols used on the power supply or in this manual where applicable.

## **GROUNDING**

To minimize shock hazard, the chassis must be connected to an electrical ground. The unit must be connected to the AC mains through a three-conductor power cable, with the ground wire firmly connected to an electrical ground (safety ground) at the power outlet.

For instruments designed to be hard-wired to the AC mains, the protective earth terminal must be connected to the safety electrical ground before another connection is made. Any interruption of the protective ground conductor or disconnection of the protective earth terminal will cause a potential shock hazard that could cause personal injury.

## **OUTPUT TERMINALS - GROUNDING**

There is a potential shock hazard at the LAN ports when KLN power supplies are used with rated or combined voltage that is greater than 400V with the Positive Output grounded. Do not connect the Positive Output to ground when the LAN is used. The output terminal can be connected by external conductor, be aware that only 105 deg. C conductor can be used.

## **CONDENSATION**

If the temperature environment of the power supply is changed suddenly (e.g., the unit is moved from a cold place to a warm place or using a heater in winter) water droplets may form inside the power supply. Condensation may also occur if the power supply is exposed to the direct wind from an air-conditioner.

To avoid damage due to condensation, please let the power supply stand at room temperature for one or two hours without connecting to the input mains power.



# TABLE OF CONTENTS

SECTION	PAGE
<b>SECTION 1 - INTRODUCTION</b>	
1.1	Scope of Manual ..... 1-1
1.2	General Description..... 1-1
1.3	Specifications ..... 1-2
1.4	Local Control ..... 1-9
1.5	Remote Control ..... 1-9
1.6	Auxiliary Control ..... 1-9
1.7	Features ..... 1-9
1.7.1	Digital Calibration..... 1-9
1.7.2	Protection..... 1-9
1.7.3	Saving and Recalling Settings ..... 1-9
1.7.4	Parallel and Series Configurations ..... 1-9
1.7.5	Miscellaneous Features ..... 1-10
1.8	Equipment Supplied ..... 1-10
1.9	Accessories ..... 1-11
1.10	Safety ..... 1-11
<b>SECTION 2 - INSTALLATION</b>	
2.1	Unpacking and Inspection ..... 2-1
2.2	Terminations and Controls ..... 2-1
2.3	Preliminary Operational Check ..... 2-3
2.4	Installation ..... 2-3
2.4.1	Input Wiring..... 2-3
2.4.2	Rack Mounting..... 2-4
2.5	Wiring Instructions ..... 2-4
2.5.1	Safety Grounding..... 2-5
2.5.2	Source Power Connections ..... 2-5
2.5.3	Installing Input Protective Cover ..... 2-5
2.5.4	D-C Output Grounding..... 2-6
2.5.5	Power Supply/Load Interface..... 2-7
2.5.6	Load Connection - General..... 2-8
2.5.6.1	Vertical Output Terminals ..... 2-9
2.5.6.2	Horizontal Output Terminals ..... 2-10
2.5.7	Load Connection Using Local Sensing..... 2-10
2.5.8	Load Connection Using Remote Sensing..... 2-11
2.5.9	Output Terminal Protective Cover Installation ..... 2-12
2.6	Load Protection ..... 2-13
2.6.1	High Capacitance Load ..... 2-13
2.6.2	Rechargeable Battery Load ..... 2-14
2.6.3	Inductive Load ..... 2-14
2.6.4	Using a Mechanical Switch to Turn Output On/Off ..... 2-14
2.6.5	PWM (Pulse Width Modulated) Load..... 2-15
2.6.6	Using a Load that Generates Reverse Current ..... 2-15
2.7	Cooling ..... 2-16
2.8	Multiple Unit Configurations ..... 2-16
2.8.1	Series Connections..... 2-16
2.8.2	Parallel Configurations..... 2-17
2.8.2.1	Parallel Wiring ..... 2-17
2.8.2.2	Parallel (Master/Slave) Setup and Power On/off Sequence ..... 2-19
2.8.2.3	Bus Bar Installation ..... 2-20
2.8.2.4	L-Bracket Installation (10KW and 15KW, 80-Volt Units Only) ..... 2-20
2.9	Setting up the unit ..... 2-21
2.9.1	Setup for Local Operation..... 2-21
2.9.2	Setup for Remote Operation via LAN ..... 2-21

# TABLE OF CONTENTS

SECTION	PAGE
<b>SECTION 3 - OPERATION</b>	
3.1	General ..... 3-1
3.2	Power Supply Basics <sup>(†)</sup> ..... 3-1
3.2.1	Front Panel Controls, Indicators and Switches <sup>(‡)</sup> ..... 3-1
3.2.2	Touchscreen Display <sup>(‡)</sup> ..... 3-2
3.2.3	Turning the Power Supply On ..... 3-4
3.2.4	Adjusting Voltage or Current <sup>(‡)</sup> ..... 3-5
3.2.4.1	Adjusting Overvoltage Protection or Undervoltage Limit <sup>(‡)</sup> ..... 3-5
3.2.4.2	Adjusting Overcurrent Protection or Undercurrent Limit <sup>(‡)</sup> ..... 3-6
3.2.5	Adjusting Overcurrent Protection Delay <sup>(‡)</sup> ..... 3-6
3.2.6	Adjusting Power <sup>(†)(‡)</sup> ..... 3-7
3.2.6.1	Adjusting Overpower Protection or Underpower Limit <sup>(‡)</sup> ..... 3-7
3.2.7	Adjusting Output ON Time <sup>(‡)</sup> ..... 3-8
3.2.8	Enabling/Disabling DC Output Power <sup>(‡)</sup> ..... 3-8
3.3	Menu Functions <sup>(‡)</sup> ..... 3-8
3.3.1	Selecting Menu Functions <sup>(‡)</sup> ..... 3-10
3.3.2	Changing Menu Values <sup>(‡)</sup> ..... 3-10
3.4	Local Mode Operation <sup>(‡)</sup> ..... 3-11
3.4.1	Viewing Error Codes <sup>(‡)</sup> ..... 3-11
3.4.2	Operating Mode <sup>(‡)</sup> ..... 3-11
3.4.2.1	Simple Mode <sup>(‡)</sup> ..... 3-11
3.4.2.2	Complete Mode <sup>(‡)</sup> ..... 3-11
3.4.2.2.1	Store/Recall of Memory Locations <sup>(‡)</sup> ..... 3-11
3.4.2.3	Sequence Mode <sup>(‡)</sup> ..... 3-12
3.4.2.3.1	Creating the Sequence FILE ..... 3-12
3.4.2.3.2	How to Enter Sequence Mode <sup>(‡)</sup> ..... 3-16
3.4.2.3.3	How to Execute Sequence(s) After Uploading <sup>(‡)</sup> ..... 3-17
3.4.2.3.4	Sequence List <sup>(‡)</sup> ..... 3-18
3.4.2.4	Insertion Mode <sup>(‡)</sup> ..... 3-18
3.4.3	Master/Slave Mode <sup>(‡)</sup> ..... 3-18
3.4.4	Power ON Mode <sup>(‡)</sup> ..... 3-19
3.4.5	Output Priority <sup>(‡)</sup> ..... 3-19
3.4.6	Output Vary Adjust <sup>(‡)</sup> ..... 3-19
3.4.7	Output Vary Recall <sup>(‡)</sup> ..... 3-20
3.4.8	Internal Resistance <sup>(†)(‡)</sup> ..... 3-20
3.4.9	Output On Ramp Time <sup>(‡)</sup> ..... 3-20
3.4.10	Output Off Ramp Time <sup>(‡)</sup> ..... 3-20
3.4.11	Voltage Slew Rate <sup>(‡)</sup> ..... 3-21
3.4.12	Current Slew Rate <sup>(‡)</sup> ..... 3-21
3.4.13	Power Slew Rate <sup>(†)(‡)</sup> ..... 3-21
3.4.14	I/O (External On/Off and Interlock) <sup>(‡)</sup> ..... 3-21
3.4.15	System Functions <sup>(‡)</sup> ..... 3-22
3.4.15.1	Alarm Buzzer Enable/Disable <sup>(‡)</sup> ..... 3-22
3.4.15.2	Key Beep Enable/Disable <sup>(‡)</sup> ..... 3-22
3.4.15.3	LCD Brightness <sup>(‡)</sup> ..... 3-22
3.4.15.4	Display Color <sup>(‡)</sup> ..... 3-22
3.4.15.5	Touch Screen Enable/Disable <sup>(‡)</sup> ..... 3-22
3.4.15.6	Network Time Synchronization <sup>(‡)</sup> ..... 3-22
3.4.15.7	Calendar Setting <sup>(‡)</sup> ..... 3-23
3.4.15.8	Time Zone Setting <sup>(‡)</sup> ..... 3-23
3.4.15.9	Calibration ..... 3-23
3.4.16	LAN Interface Settings <sup>(‡)</sup> ..... 3-23
3.4.16.1	IP Information <sup>(‡)</sup> ..... 3-23
3.4.16.2	Auto IP <sup>(‡)</sup> ..... 3-23
3.4.16.3	Manual IP <sup>(‡)</sup> ..... 3-23
3.4.16.4	SCPI-RAW Port <sup>(‡)</sup> ..... 3-24

# TABLE OF CONTENTS

SECTION		PAGE
3.4.16.5	Message Terminator(†) .....	3-24
3.4.16.6	NTP Server(†) .....	3-24
3.4.16.7	REset LAN(†) .....	3-25
3.4.17	Optional Interface Settings(†) .....	3-25
3.4.17.1	Analog Interface(†) .....	3-25
3.4.17.1.1	Analog Voltage Level(†) .....	3-25
3.4.17.1.2	Analog Voltage Programming Enable/Disable(†) .....	3-25
3.4.17.1.3	Analog Current Programming Enable/Disable(†) .....	3-25
3.4.17.1.4	Analog Power Programming Enable/Disable(†) .....	3-25
3.4.17.1.5	Analog Monitor Output Enable/Disable(†) .....	3-25
3.4.17.2	RS 422/RS 485 & USB Interface(†) .....	3-25
3.4.17.2.1	RS 422/RS 485 Mode Select(†) .....	3-26
3.4.17.2.2	RS 422/RS 485 Address Mode Enable/Disable(†) .....	3-26
3.4.17.2.3	RS 422/RS 485 Terminal Resistor Enable/Disable(†) .....	3-26
3.4.17.2.4	RS 422/RS 485 Address(†) .....	3-26
3.4.17.2.5	RS 422/RS 485 Baud Rate(†) .....	3-26
3.4.17.2.6	RS 422/RS 485 Data Bit(†) .....	3-26
3.4.17.2.7	RS 422/RS 485 Flow Control(†) .....	3-26
3.4.17.2.8	RS 422/RS 485 Message Terminator(†) .....	3-26
3.4.17.3	IEEE 488 (GPIB) Interface(†) .....	3-26
3.4.17.3.1	GPIB Address View/Set(†) .....	3-26
3.4.18	Information Menu(†) .....	3-27
3.4.18.1	System Information(†) .....	3-27
3.4.18.2	Contact Us(†) .....	3-27
3.4.18.3	System Log(†) .....	3-27
3.4.19	Load Default(†) .....	3-27
3.5	Firmware Upgrade(†) .....	3-27
3.6	Series/Parallel Operation .....	3-27
3.6.1	Series Operation .....	3-27
3.6.2	Discontinuing Series Operation .....	3-28
3.6.3	Parallel Operation .....	3-28
3.6.4	Discontinuing Parallel Operation .....	3-28
3.7	Using the I/O Auxiliary Port .....	3-29
3.7.1	External OUTPUT On/off .....	3-29
3.7.2	External OUTPUT Shutoff .....	3-29
3.7.3	Monitoring Status Using I/O Auxiliary Port .....	3-29
3.7.4	Interlock Control .....	3-29
3.8	Digital Remote Mode Programming .....	3-30
3.8.1	LAN Operation .....	3-30
3.8.1.1	Instrument Welcome (Home) Page .....	3-30
3.8.1.2	Network Status .....	3-31
3.8.1.3	Viewing and/or Changing IP Configuration .....	3-31
3.8.1.4	Changing LAN Password .....	3-33
3.8.1.5	Instrument Control .....	3-34
3.8.1.6	Using Terminal Emulation Software To Verify Correct Connection .....	3-36
3.9	SCPI Programming .....	3-38
3.9.1	SCPI Messages .....	3-39
3.9.2	Common Commands/Queries .....	3-39
3.9.3	SCPI Subsystem Command/query Structure .....	3-39
3.9.3.1	Abort Subsystem .....	3-39
3.9.3.2	Calibrate Subsystem .....	3-39
3.9.3.3	Display Subsystem .....	3-39
3.9.3.4	Fetch Subsystem .....	3-39
3.9.3.5	Initiate Subsystem .....	3-40
3.9.3.6	LXI Subsystem .....	3-40
3.9.3.7	Measure Subsystem .....	3-40
3.9.3.8	Memory Subsystem .....	3-40

# TABLE OF CONTENTS

SECTION	PAGE
3.9.3.9	Output Subsystem..... 3-40
3.9.3.10	Source Subsystem ..... 3-40
3.9.3.11	System Subsystem ..... 3-40
3.9.3.12	Trigger Subsystem ..... 3-40
3.9.4	Understanding The Command Structure ..... 3-40
3.10	Optional Interfaces..... 3-41
3.10.1	Isolated Analog Optional Interface..... 3-41
3.10.2	IEEE 488.2 (GPIB)..... 3-42
3.10.2.1	IEEE 488 (GPIB) Bus Protocol..... 3-44
3.10.3	Serial (RS422/RS485) & USB..... 3-44
3.10.3.1	RS 422 Interface ..... 3-45
3.10.3.2	RS 485 Interface ..... 3-46
3.10.3.3	USB Interface..... 3-46
3.11	Operator Maintenance ..... 3-46

## SECTION 4 - CALIBRATION

4.1	General..... 4-1
4.2	Equipment Required ..... 4-1
4.3	Preliminary Setup ..... 4-1
4.4	Voltage Calibration Procedure <sup>(†)</sup> ..... 4-2
4.5	Current Calibration Procedure <sup>(‡)</sup> ..... 4-3

## APPENDIX A - SCPI COMMON COMMAND/QUERY DEFINITIONS

A.2	*CLS — Clear Status Command ..... A-1
A.3	*ESE — Event Status Enable Command ..... A-1
A.4	*ESE? — Event Status Enable Query ..... A-1
A.5	*ESR — Event Status Enable Command ..... A-1
A.6	*ESR? — Event Status Enable Query ..... A-2
A.7	*IDN? — Identification Query..... A-2
A.8	*OPC — Operation Complete Command ..... A-2
A.9	*OPC? — Operation Complete Query ..... A-2
A.10	Optional Interface Query..... A-2
A.11	*RST — Reset Command..... A-2
A.12	*SRE — Service Request Enable Command ..... A-2
A.13	*SRE? — Service Request Enable Query ..... A-3
A.14	*TRG — Trigger Command ..... A-3
A.15	*TST? — Self Test Query ..... A-3
A.16	*WAI — Wait Command ..... A-3

## APPENDIX B - SCPI COMMAND/QUERY DEFINITIONS

B.1	Introduction..... B-1
B.2	Numerical Values..... B-2
B.3	ABORt:TRANsient Command..... B-2
B.4	DISPlay Command ..... B-2
B.5	DISPlay? Query ..... B-2
B.6	DISPlay:BRIGhtness Command..... B-3
B.7	DISPlay:BRIGhtness? Query..... B-3
B.8	FETCh? Query..... B-3
B.9	INITiate:TRANsient Command ..... B-3
B.10	INITiate:CONTInuous:TRANsient Command ..... B-3
B.11	LXI:IDentify Command..... B-3
B.12	MEASure[:SCALar]:CURRent[:DC]? Query ..... B-4
B.13	MEASure[:SCALar]:POWer[:DC]? Query <sup>(†)</sup> ..... B-4



# TABLE OF CONTENTS

SECTION		PAGE
B.14	MEASure[:SCALar]:VOLTage[:DC]? Query .....	B-4
B.15	MEMory:CLS Command .....	B-4
B.16	MEMory:CURRent Command .....	B-4
B.17	MEMory:CURRent? Query .....	B-4
B.18	MEMory:LIST? Query .....	B-5
B.19	MEMory:POWer Command <sup>(†)</sup> .....	B-5
B.20	MEMory:POWer? Query <sup>(†)</sup> .....	B-5
B.21	MEMory:RECall Command .....	B-5
B.22	MEMory:RECall? Query .....	B-5
B.23	MEMory:TABLE:VOLTage Command .....	B-6
B.24	MEMory:TABLE[:SASimulator]:VOLTage:POINts? Query .....	B-6
B.25	MEMory:TIME Command .....	B-6
B.26	MEMory:TIME? Query .....	B-6
B.27	MEMory:VOLTage Command .....	B-6
B.28	MEMory:VOLTage? Query .....	B-6
B.29	OUTPut Command .....	B-7
B.30	OUTPut? Query .....	B-7
B.31	OUTPut:PON Command .....	B-7
B.32	OUTPut:PON? Query .....	B-7
B.33	OUTPut:PRIOrity Command .....	B-7
B.34	OUTPut:PRIOrity? Query .....	B-8
B.35	OUTPut:PROTection:CLEar Command .....	B-8
B.36	TRIGger:TRANsient[:IMMediate] Command .....	B-8
B.37	TRIGger:TRANsient:SOURce Command .....	B-8
B.38	TRIGger:TRANsient:SOURce? Query .....	B-8
B.39	[SOURce:]CURRent[:LEVel][:IMMediate][:AMPLitude] Command .....	B-9
B.40	[SOURce:]CURRent[:LEVel][:IMMediate][:AMPLitude]? Query .....	B-9
B.41	[SOURce:]CURRent:MODE Command .....	B-9
B.42	[SOURce:]CURRent:MODE? Query .....	B-9
B.43	[SOURce:]CURRent:PROTection:DELay Command .....	B-9
B.44	[SOURce:]CURRent:PROTection:DELay? Query .....	B-10
B.45	[SOURce:]CURRent:PROTection:LEVel Command .....	B-10
B.46	[SOURce:]CURRent:PROTection:LEVel? Query .....	B-10
B.47	[SOURce:]CURRent:PROTection:STATe Command .....	B-10
B.48	[SOURce:]CURRent:PROTection:STATe? Query .....	B-10
B.49	[SOURce:]CURRent:SLEW:RATE Command .....	B-11
B.50	[SOURce:]CURRent:SLEW:RATE? Query .....	B-11
B.51	[SOURce:]CURRent[:LEVel]:TRIGgerred Command .....	B-11
B.52	[SOURce:]CURRent[:LEVel]:TRIGgerred? Query .....	B-11
B.53	[SOURce:]FUNCTion:SEQuence Command .....	B-11
B.54	[SOURce:]FUNCTion:SEQuence? Query .....	B-12
B.55	[SOURce:]FUNCTion:SEQuence:COMPLete Command .....	B-12
B.56	[SOURce:]FUNCTion:SEQuence:COMPLete? Query .....	B-12
B.57	[SOURce:]FUNCTion:SEQuence:CURRent Command .....	B-12
B.58	[SOURce:]FUNCTion:SEQuence:CURRent? Query .....	B-12
B.59	[SOURce:]FUNCTion:SEQuence:EDIT Command .....	B-13
B.60	[SOURce:]FUNCTion:SEQuence:EDIT? Query .....	B-13
B.61	[SOURce:]FUNCTion:SEQuence:END Command .....	B-13
B.62	[SOURce:]FUNCTion:SEQuence:END? Query .....	B-13
B.63	[SOURce:]FUNCTion:SEQuence:LIST Command .....	B-13
B.64	[SOURce:]FUNCTion:SEQuence:LIST? Query .....	B-14
B.65	[SOURce:]FUNCTion:SEQuence:LOOP Command .....	B-14
B.66	[SOURce:]FUNCTion:SEQuence:LOOP? Query .....	B-14
B.67	[SOURce:]FUNCTion:SEQuence:NOW? Query .....	B-14
B.68	[SOURce:]FUNCTion:SEQuence:POWer Command <sup>(†)</sup> .....	B-14
B.69	[SOURce:]FUNCTion:SEQuence:POWer? Query <sup>(†)</sup> .....	B-14
B.70	[SOURce:]FUNCTion:SEQuence:STEP Command .....	B-15

# TABLE OF CONTENTS

SECTION		PAGE
B.71	[SOURce:]FUNctIon:SEQuence:STEP? Query .....	B-15
B.72	[SOURce:]FUNctIon:SEQuence:TIME Command .....	B-15
B.73	[SOURce:]FUNctIon:SEQuence:TIME? Query .....	B-15
B.74	[SOURce:]FUNctIon:SEQuence:VOLTagE Command .....	B-15
B.75	[SOURce:]FUNctIon:SEQuence:VOLTagE? Query .....	B-15
B.76	[SOURce:]MODE Command .....	B-16
B.77	[SOURce:]MODE? Query .....	B-16
B.78	[SOURce:]POWer[:LEVel][:IMMediate][:AMPlitude] Command <sup>(†)</sup> .....	B-16
B.79	[SOURce:]POWer[:LEVel][:IMMediate][:AMPlitude]? Query <sup>(†)</sup> .....	B-16
B.80	[SOURce:]POWer:PROtEction:LEVel Command .....	B-16
B.81	[SOURce:]POWer:PROtEction:LEVel? Query .....	B-17
B.82	[SOURce:]POWer:SLEW:RATE Command <sup>(†)</sup> .....	B-17
B.83	[SOURce:]POWer:SLEW:RATE? Query <sup>(†)</sup> .....	B-17
B.84	[SOURce:]RESistance Command <sup>(†)</sup> .....	B-17
B.85	[SOURce:]RESistance? Query <sup>(†)</sup> .....	B-17
B.86	[SOURce:]TIME Command .....	B-18
B.87	[SOURce:]TIME? Query .....	B-18
B.88	[SOURce:]VOLTagE[:LEVel][:IMMediate][:AMPlitude] Command .....	B-18
B.89	[SOURce:]VOLTagE[:LEVel][:IMMediate][:AMPlitude]? Query .....	B-18
B.90	[SOURce:]VOLTagE:MODE Command .....	B-18
B.91	[SOURce:]VOLTagE:MODE? Query .....	B-19
B.92	[SOURce:]VOLTagE:PROtEction[:LEVel] Command .....	B-19
B.93	[SOURce:]VOLTagE:PROtEction[:LEVel]? Query .....	B-19
B.94	[SOURce:]VOLTagE:SLEW:RATE Command .....	B-19
B.95	[SOURce:]VOLTagE:SLEW:RATE? Query .....	B-19
B.96	[SOURce:]VOLTagE[:LEVel]:TRIGgerred Command .....	B-20
B.97	[SOURce:]VOLTagE[:LEVel]:TRIGgerred? Query .....	B-20
B.98	STATus:OPERation:CONDition? Query .....	B-20
B.99	STATus:OPERation:ENABle Command .....	B-20
B.100	STATus:OPERation:ENABle? Query .....	B-20
B.101	STATus:OPERation:EVENT? Query .....	B-21
B.102	STATus:OPERation:NTRansition Command .....	B-21
B.103	STATus:OPERation:NTRansition? Query .....	B-21
B.104	STATus:OPERation:PTRansition Command .....	B-21
B.105	STATus:OPERation:PTRansition? Query .....	B-21
B.106	STATus:QUEStionable:CONDition? Query .....	B-22
B.107	STATus:QUEStionable:ENABle Command .....	B-22
B.108	STATus:QUEStionable:ENABle? Query .....	B-22
B.109	STATus:QUEStionable:EVENT? Query .....	B-22
B.110	STATus:QUEStionable:NTRansition Command .....	B-23
B.111	STATus:QUEStionable:NTRansition? Query .....	B-23
B.112	STATus:QUEStionable:PTRansition Command .....	B-23
B.113	STATus:QUEStionable:PTRansition? Query .....	B-23
B.114	SYSTem:BEEP Command .....	B-24
B.115	SYSTem:BEEP? Query .....	B-24
B.116	SYSTem:BUZZer Command .....	B-24
B.117	SYSTem:BUZZer? Query .....	B-24
B.118	SYSTem:COMMunicate:RLState Command .....	B-24
B.119	SYSTem:COMMunicate:TCP:CONTRol? Query .....	B-24
B.120	SYSTem:DATE Command .....	B-25
B.121	SYSTem:DATE? Query .....	B-25
B.122	SYSTem:ERRor? Query .....	B-25

# TABLE OF CONTENTS

SECTION		PAGE
B.123	SYSTem:LOCAl Command .....	B-27
B.124	SYSTem:LOG:LAST? Query.....	B-28
B.125	SYSTem:LOG:PREV? Query.....	B-28
B.126	SYSTem:MS:MODE Command .....	B-28
B.127	SYSTem:MS:MODE? Query .....	B-28
B.128	SYSTem:MS:NUMber? Query .....	B-28
B.129	SYSTem:NTP Command .....	B-29
B.130	SYSTem:NTP? Query .....	B-29
B.131	SYSTem:NTP:SERVer Command .....	B-29
B.132	SYSTem:NTP:SERVer? Query .....	B-29
B.133	SYSTem:REMOte Command .....	B-29
B.134	SYSTem:RWLock Command.....	B-29
B.135	SYSTem:TIME Command.....	B-30
B.136	SYSTem:TIME? Query.....	B-30
B.137	SYSTem:VERSion? Query.....	B-30
B.138	SYSTem:ZONE Command .....	B-30
B.139	SYSTem:ZONE? Query .....	B-30

# LIST OF FIGURES

FIGURE	TITLE	PAGE
1-1	KLN-EXT (Extended Range) Series Power Supply.....	xii
1-2	KLN EXT Extended Operating Range.....	1-2
1-3	KLN EXT Voltage and Current Parameters Used in Table 1-2.....	1-2
1-4	KLN EXT 5KW, 10KW, 15KW Power Supply, Outline Drawing.....	1-8
2-1	KLN Extended Range Series Rear Panel.....	2-1
2-2	Rack Mounting.....	2-4
2-3	Input Wiring and Input Cover Installation.....	2-6
2-4	Connection of Single or Multiple Loads to Output Terminals.....	2-8
2-5	Vertical Output Terminal Dimensions (All except 5KW and 10KW 80-Volt Models).....	2-9
2-6	Load Connection, Vertical Output Terminals, Typical.....	2-9
2-7	Horizontal Output Terminal Dimensions (10KW and 15KW 80-Volt Models).....	2-10
2-8	Load Connection, Horizontal Output Terminals, Typical.....	2-10
2-9	Load Connections, Local Sensing.....	2-11
2-10	Load Wire Voltage Drop, Equivalent Schematic Diagram.....	2-11
2-11	Load Connections, Remote Sensing.....	2-12
2-12	Output Terminals Protective Cover Installation.....	2-13
2-13	Using Blocking Diode with High Capacitance Load.....	2-13
2-14	Using Blocking Diode with Rechargeable Battery.....	2-14
2-15	Using Free Wheel Diode with Inductive Load.....	2-14
2-16	Using mechanical Switch to Turn Output On/Off.....	2-14
2-17	Typical Current Waveforms for PWM Load.....	2-15
2-18	Using Capacitor with PWM Load.....	2-15
2-19	Using resistor and Capacitor to Absorb reverse Current.....	2-15
2-20	Series Connections.....	2-17
2-21	Parallel Connections.....	2-18
2-22	Bus Bar Installation.....	2-20
2-23	L-Bracket Installation.....	2-21
2-24	LAN Connections.....	2-22
3-1	KLN EXT Series Front Panel <sup>(†)</sup> .....	3-1
3-2	Home Screen <sup>(‡)</sup> .....	3-3
3-3	Touchscreen Setting of Voltage, Overvoltage Protection and Undervoltage Limit.....	3-5
3-4	Touchscreen Setting of Current, Overcurrent Protection, Undercurrent Limit and Protection Delay <sup>(†)</sup> .....	3-6
3-5	Touchscreen Setting of Power, Overpower Protection and Underpower Limit <sup>(†)(‡)</sup> .....	3-7
3-6	Touchscreen Setting of Output ON Time.....	3-8
3-7	Menu Structure <sup>(‡)</sup> .....	3-9
3-8	MENU Selections, Top Level.....	3-10
3-9	Changing Values, Using Output ON Ramp Time as Example.....	3-10
3-10	Sequence Example 1, Format for a Single Sequence.....	3-13
3-11	Sequence Example 1, Power Supply Output.....	3-13
3-12	Sequence Example 2, Format for two Sequences.....	3-14
3-13	Sequence Example 2, Power Supply Output.....	3-14
3-14	Home Screen After Uploading Sequence File <sup>(†)</sup> .....	3-17
3-15	Home Screen Showing Sequence Running and Paused <sup>(†)</sup> .....	3-17
3-16	Home Screen When Insertion Mode Selected <sup>(†)</sup> .....	3-18
3-17	Output ON/OFF and Output ShutoFF Control Using I/O Auxiliary Port and Optocoupler or Relay.....	3-29
3-18	Instrument Welcome (Home) Page.....	3-30
3-19	Network Status Page.....	3-31
3-20	LogIn Screen.....	3-31
3-21	Network Configuration Page.....	3-32
3-22	Change Password Screen.....	3-33
3-23	Instrument Control Page.....	3-35
3-24	Terminal Emulation Configuration.....	3-36
3-25	Configure Terminal.....	3-37
3-26	Configure Session.....	3-37

# LIST OF FIGURES

FIGURE	TITLE	PAGE
3-27	Configure Terminal Keyboard .....	3-38
3-28	Send Commands to Unit Via Terminal Emulator .....	3-38
3-29	Analog Control Connector, Pin Assignments .....	3-41
3-30	Analog Control, Typical Connections, Schematic Diagram.....	3-42
3-31	GPIB Connections .....	3-43
3-32	RS 422/RS 485 and USB Interface, Connectors and Pins .....	3-44
3-33	RS 422 Connections .....	3-45
3-34	RS 485 Connections .....	3-46
3-35	Tree Diagram of SCPI Commands Used with KLN Power Supply .....	3-47
4-1	Calibration Setup .....	4-2
4-2	Entering Password to Access Calibration .....	4-3
4-3	Voltage Ratio Calibration .....	4-3
4-4	Current Ratio Calibration .....	4-4

# LIST OF TABLES

TABLE	TITLE	PAGE
1-1	Manual Modifications Depending on MODEL Suffix .....	1-1
1-2	KLN EXT Series Model Specifications .....	1-3
1-3	KLN EXT General Specifications .....	1-4
1-4	Equipment Supplied .....	1-10
1-5	Accessories .....	1-11
1-6	Safety Symbols .....	1-12
2-1	Rear Panel Connector Functions .....	2-1
2-2	I/O Auxiliary Port Input/Output Pin Assignments .....	2-2
2-3	Input Wiring Specifications .....	2-3
2-4	Recommended Cable Gauge and Resistance by Length .....	2-12
3-1	Front Panel Controls and Indicators <sup>(†)</sup> .....	3-2
3-2	Touchscreen Display <sup>(‡)</sup> .....	3-3
3-3	Factory Defaults .....	3-4
3-4	Simulated Internal Resistance Range .....	3-21
3-5	Instrument Control Page .....	3-34
3-6	VISA Resource String Corresponding to Interface .....	3-39
3-7	Analog Control Connector Pin Functions .....	3-41
3-8	IEEE 488 Port Connector (J4) Pin Assignments .....	3-43
3-9	IEEE 488 (GPIB) Bus Interface Functions .....	3-44
3-10	RS 422/RS 485, USB Interface Connector/Pin Functions .....	3-45
A-1	IEEE 488.2 Command/query Index .....	A-1
A-2	Standard Event Status Enable Register Bits .....	A-1
B-1	SCPI Subsystem Command/query Index .....	B-1
B-2	Operation Condition Register, Operation Enable Register, and Operation Event Register Bits .....	B-20
B-3	Questionable Condition Register, Questionable Enable Register, and Questionable Event Register Bits .....	B-22
B-4	Error Codes .....	B-25





3044162

FIGURE 1-1. KLN-EXT (EXTENDED RANGE) SERIES POWER SUPPLY



## SECTION 1 - INTRODUCTION

### 1.1 SCOPE OF MANUAL

This manual contains instructions for the installation and operation of the KLN series of 5KW, 10KW, and 15KW Watt programmable, extended range, voltage and current stabilized d-c power supplies, hereafter referred to as KLN EXT, from Kepco, Inc., Flushing, New York, U.S.A. Table 1-1 presents the features and corresponding instructions regarding use of this manual for the models covered.

**TABLE 1-1. MANUAL MODIFICATIONS DEPENDING ON MODEL SUFFIX**

Suffix	Features	Manual Modifications
E	Standard model. Includes ethernet interface, touch screen display and adjustable constant power.	No modifications required. All features included.
EX	Same as E suffix, except smaller touch screen display, no adjustable power limit and no internal resistance simulation.	<ol style="list-style-type: none"> <li>1. Ignore references to adjustable constant power. Power limit is fixed and not adjustable.</li> <li>2. Ignore references to Internal Resistance Simulation</li> </ol>
EB	Same as E suffix, except front panel is blank: no front panel controls and no front panel display.	References to display, touch screen and front panel controls are not applicable. Use browser with LAN interface or IEEE 488.2 and SCPI commands to substitute remote control for local control.
EN	Same as EX suffix, except front panel is blank: no front panel controls and no front panel display.	<ol style="list-style-type: none"> <li>1. References to display, touch screen and front panel controls are not applicable. Use browser with LAN interface or IEEE 488.2 and SCPI commands for remote control (see Appendices A and B).</li> <li>2. Ignore references to adjustable constant power. Power limit is fixed and not adjustable.</li> <li>3. Ignore references to Internal Resistance simulation</li> </ol>

### 1.2 GENERAL DESCRIPTION

KLN EXT Extended Range Series power supplies are voltage and current stabilized d-c sources with user selection of adjustable constant voltage, constant current and constant power modes<sup>(†)</sup> of operation. Eighteen models are offered (see Table 1-2), with rated d-c output voltage ranging from 80V to 650V (5KW maximum power limit), 80V to 1000V (10KW maximum power limit) and 80V to 1500V (15KW maximum power limit) and rated d-c output current ranging from 23A to 180A (5KW), 30A to 360A (10KW) and 30A to 540A (15KW).

KLN EXT switching power supplies operate from 3-phase wide range 180-460V a-c, 47/63 Hz input source power and employ active power factor correction (PFC). Since there are no internal adjustments, KLN EXT Power Supplies offer excellent output voltage/current stability and easy calibration.

Extended Range refers to the extended hyperbolic output operating range of each model when compared to a conventional power supply with a conventional rectangular operating region

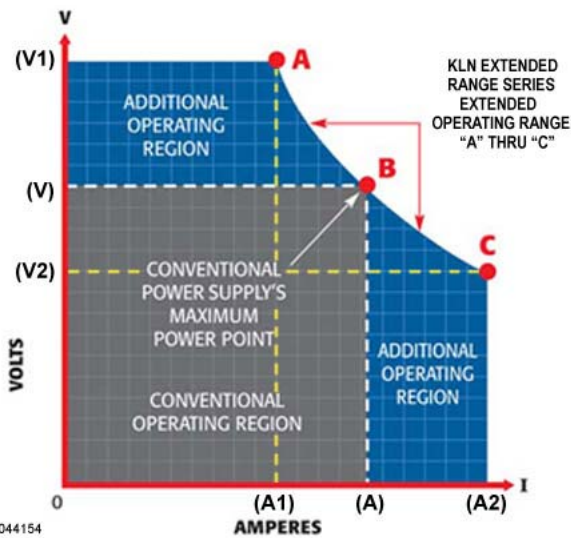

Referring to the adjacent figure, a conventional output power range would require three power supplies to meet the following requirements:

$$V \times A = \text{Rated Power}$$

$$V1 \times A1 = \text{Rated Power}$$

$$V2 \times A2 = \text{Rated Power}$$

The constant power technique used by the KLN Extended Range Series allows a single power supply to meet the three requirements noted above for  $V \times A$ ,  $V1 \times A1$  and  $V2 \times A2$ , plus all points within the area formed by the arc bounded by "A", "B" and "C". This is possible because the maximum voltage and current are not fixed, but are limited by the maximum power of the KLN Extended Range power supply.

**FIGURE 1-2. KLN EXT EXTENDED OPERATING RANGE**

Output voltage and current are displayed on a touch-screen display<sup>(†)</sup>. Control of the KLN EXT can be either local, via the front panel controls and display<sup>(†)</sup>, or remote, using digital programming. Remote programming of standard models is via the LAN interface using a browser or IEEE488.2 and SCPI commands and queries. In addition to the LAN interface, one of the following optional interfaces may also be installed: IEEE 488.2 (GPIB) (suffix G), Serial/USB (RS422/RS485 & USB) (suffix U) and Isolated Analog (suffix A).

The KLN EXT series is suitable for ATE (Automatic Test Equipment) testing, burn-in tests and other applications that require lots of testing power.

### 1.3 SPECIFICATIONS

Table 1-2 below indicates specifications that vary for different KLN EXT models; Figure 1-3 illustrates the voltage and current parameters used in Table 1-2. Table 1-3 lists general specifications that apply to all KLN EXT models.

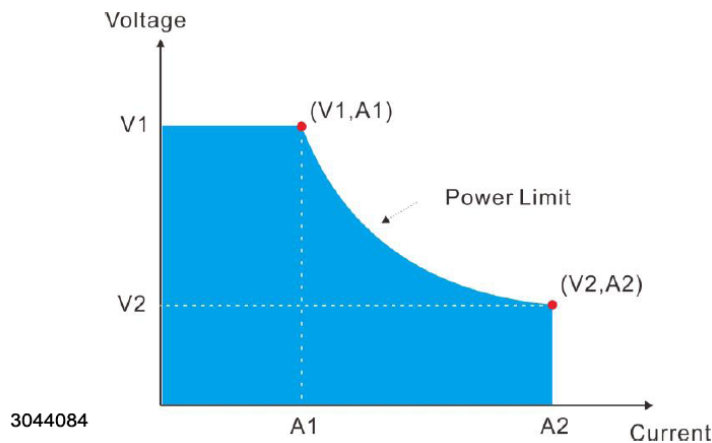

**FIGURE 1-3. KLN EXT VOLTAGE AND CURRENT PARAMETERS USED IN TABLE 1-2**

**TABLE 1-2. KLN EXT SERIES MODEL SPECIFICATIONS**

Model (1)	Maximum Power	Rated Voltage (2)	Maximum Current for Rated Voltage	Rated Current (2)	Maximum Voltage for Rated Current	Ripple and Noise		Internal Resistance <sup>(†)</sup>
		V1 (3)	A1 (3)	A2 (3)	V2 (3)	CV	CC	
	KW	V d-c	A d-c	A d-c	V d-c	mV rms	mA rms	Ohms
<b>5KW 3U Full Rack Extended Range Models</b>								
KLN 80-180	5	80	62.5	180	27.78	16	85	0 ~ 0.444
KLN 250-60	5	250	57	250	83.33	50	83.3	0 - 4.17
KLN 350-42	5	350	14.28	42	119.05	60	51	0 - 8.33
KLN 500-30	5	500	10	30	166.67	70	48	0 - 16.7
KLN 650-23	5	650	7.69	23	217.39	170	16	0 - 28.3
<b>10KW 3U Full Rack Extended Range Models</b>								
KLN 80-360	10	80	125	360	27.78	25	170	0 ~ 0.222
KLN 250-120	10	250	40	120	83.33	50	36	0 - 2.08
KLN 350-84	10	350	28.56	84	119.05	60	34	0 - 4.17
KLN 500-60	10	500	20	60	166.67	70	32	0 - 8.33
KLN 650-46	10	650	15.38	46	217.39	170	32	0 - 14.1
KLN 1000-30	10	1000	10	30	333.33	350	22	0 - 33.3
<b>15KW 3U Full Rack Extended Range Models</b>								
KLN 80-540	15	80	187.5	540	27.78	25	255	0 ~ 0.148
KLN 250-180	15	250	60	180	83.33	50	57	0 - 1.39
KLN 350-126	15	350	42.84	126	119.05	60	51	0 - 2.78
KLN 500-90	15	500	30	90	166.67	70	48	0 - 5.56
KLN 650-69	15	650	23.07	69	217.39	170	48	0 - 9.42
KLN 1050-42	15	1050	14.29	42	357.14	350	35	0 - 25.0
KLN 1500-30	15	1500	10	30	500	400	26	0 - 50.0

**NOTES:**

- For the KLN Extended Range Series each Model number KLN [V]-[C][*model*][*option*] describes Rated Voltage, Rated Current, model and optional interface where:  
V = Rated Voltage in Volts  
C = Rated Current in Amperes  
[*model*] = E = Standard model, includes, Ethernet LAN (LXI) Interface, touch screen display, adjustable power limit, internal resistance simulation  
EX = Same as E, except smaller display, no adjustable power limit, no internal resistance simulation  
EB = Same as E, except front panel is blank: no front panel controls and no front panel display.  
EN = Same as EX, except front panel is blank: no front panel controls and no front panel display.  
[*option*] = G = Includes Ethernet LAN (LXI) Interface, plus optional GPIB Interface  
U = Includes Ethernet LAN (LXI) Interface, plus optional RS 422/RS 485 + USB Interface  
A = Includes Ethernet LAN (LXI) Interface, plus optional Isolated Analog Interface  
As an example, KLN 80-540EG indicates standard model: Rated Voltage = 80V, Rated Current = 540A (Maximum Power = 5KW, adjustable<sup>(†)</sup>) with LAN (LXI) interface plus optional GPIB interface.
- Maximum value of output voltage and current is 105% of rated value.
- Refer to Figure 1-3 for a graphical representation of V1, V2, A1 and A2.

**TABLE 1-3. KLN EXT GENERAL SPECIFICATIONS**

SPECIFICATION <sup>(1)</sup>	RATING/DESCRIPTION		
	5KW	10KW	15KW
<b>INPUT CHARACTERISTICS</b>			
Input voltage,	Nominal	200 ~ 415V a-c, 3Φ, 3W or 4W	
	Range	180 ~ 460V a-c	180 ~ 460V a-c or 430 ~ 530V a-c
Input Frequency	Nominal	50/60Hz	
	Range	47/63Hz	
Input current	Max.	8.5A <sup>(2)</sup>	17A <sup>(2)</sup> 25A <sup>(2)</sup>
Inrush current	Max.	30A <sup>(2)</sup>	60A <sup>(2)</sup> 90A <sup>(2)</sup>
Input Power	Max.	6KVA	12KVA      18KVA
Efficiency	Min.	90% <sup>(3)</sup>	
Power Factor (PF)	Typ.	0.95	
Ground polarity		Either positive or negative ground <sup>(4)</sup>	
Isolation Voltage	Primary-chassis:	2500V d-c, 1 minute	
	Primary-secondary:	2500V d-c, 1 minute	
	Secondary-chassis:	300V d-c, 1 minute <sup>(4)</sup>	
<b>OUTPUT CHARACTERISTICS</b>			
Type of Stabilizer		Constant Voltage (CV), Constant Current (CC), user selectable	
Adjustment Range	Voltage:	0 to 105% of rated voltage	
	Current:	0 to 105% of rated current	
Protective functions		Programmable overvoltage (OVP), Undervoltage Limit (UVL) Programmable overcurrent (OCP), Undercurrent Limit (UCL) Programmable overpower (OPP), Underpower Limit (UPL) Overtemperature (OTP), Source power fail	
Protection setting range	Overvoltage:	0% to 110% of rated voltage	
	Overcurrent:	0% to 110% of rated current	
	Overpower	0% to 110% of rated power	
	Undervoltage limit:	0% to 105% of rated voltage	
	Undercurrent limit:	0% to 105% of rated current	
	Underpower limit:	0% to 102% of rated current	
Remote Error Sense Compensation		5V max.	

(1) Specifications apply after 30 minute warm-up, ambient temperature 23±5°C, humidity under 80% RH, input a-c voltage ±5%, frequency ±5%. Unless otherwise noted, specifications apply only with nominal input voltage.

(2) Input voltage: 415V a-c, 3-phase.

(3) Input voltage: 415V a-c, 3-phase, rated output voltage and output current.

(4) Grounding of + output terminal not permitted for models rated higher than 300V.

**TABLE 1-3. KLN EXT GENERAL SPECIFICATIONS (CONTINUED)**

SPECIFICATION <sup>(1)</sup>	RATING/DESCRIPTION		
	5KW	10KW	15KW
<b>OUTPUT CHARACTERISTICS - CONTINUED</b>			
Source Effect	Voltage:	±0.02% of rated voltage	
	Current:	±0.05% of rated current	
	Power:	±0.05% of maximum power	
Load Effect	Voltage:	±0.05% of rated voltage <sup>(5)</sup>	
	Current:	±0.15% of rated current <sup>(6)</sup>	
	Power:	±0.75% of maximum power <sup>(7)</sup>	
Parallel Operation	Up to 10 units maximum, automatic load sharing		
Series Operation	2 units maximum (total voltage must not exceed 1500V maximum)		
Temperature Coefficient	100ppm/°C of rated output voltage after 30 minutes warm-up		
Response Time	Full load (up):	0.03 Sec	
	Full load (down):	0.08 Sec	
	No load (down):	80V to 350V: 30 Sec, 500V and higher: 10 Sec	
Transient response time (CV Mode)	20V and under:	≤1.5ms	
	30V~100V:	≤1ms	
	150V~600V:	≤2ms	
<b>PROGRAMMING CHARACTERISTICS - LOCAL <sup>(‡)</sup></b>			
Local Control	Separate Voltage and Current encoders, Menu select, touch screen		
Setting resolution	Voltage and Current:	5 digits	
Display resolution	Voltage and Current:	80V Models: 5 digits 1mV/1mA 250V ~ 650V models: 5 digits 10mV/10mA 1050V ~ 1500V models: 5 digits 100mV/100mA	
Programming Accuracy	Voltage:	±0.1% of rated voltage + 2 digits	
	Current:	±0.2% of rated current + 2 digits	
Display Accuracy	Voltage:	±0.1% of rated voltage + 2 digits	
	Current:	±0.2% of rated current + 2 digits	
Overvoltage Protection (OVP)	Programmable, 0 to 110% of rated voltage		
Overcurrent Protection (OCP)	Programmable, 0 to 110% of rated current		
Overpower Protection (OPP)	Programmable*, 0 to 110% of rated power		

(5) Output current changes within 10% to 90% of rated current.

(6) Output voltage changes within 10% to 100% of rated voltage.

(7) Output power within 10% to 90% of voltage x current.

**TABLE 1-3. KLN EXT GENERAL SPECIFICATIONS (CONTINUED)**

SPECIFICATION <sup>(1)</sup>	RATING/DESCRIPTION		
	5KW	10KW	15KW
<b>PROGRAMMING CHARACTERISTICS - DIGITAL</b>			
Programming accuracy	Voltage:	±(0.1% of rated voltage + 2 digits)	
	Current:	±(0.2% of rated current + 2 digits)	
Measurement accuracy	Voltage:	±(0.1% of rated voltage + 2 digits)	
	Current:	±(0.2% of rated current + 2 digits)	
Command response time	<10mS after received, LAN interface (8)		
LAN (LXI) Digital Interface	Standard, built-in to all models		
Serial Port RS-485/RS 422 &USB Digital Interface	Optional: Suffix U added to standard interface (Contact Kepco for further information)		
	Baud rate:	Select 4.8K, 9.6K, 19.2K, 38.4K, 57.6K, or 115.2K (default, max)	
	Max no.of units connected to bus:	254	
	Max. effective control distance:	1000 meters.	
GPIB Digital Interface	Optional: Suffix G, added to standard interface (Contact Kepco for further information)		
Analog interface	Optional: Suffix A, added to standard interface (Contact Kepco for further information)		
Programming interface	IVI-COM driver provided, SCPI commands supported.		
Programmable Output Ramp	Ramp up time:	Adjustable range 0.1 to 99.9 Sec	
	Ramp down time:	Adjustable range 0.1 to 99.9 Sec	
User-programmed Memory Locations	8000 sets, each capable of storing Voltage, Current, Power and Time (0.1mS min.). USB port provided for convenient loading of memory locations. Three sets can be stored/recalled from front panel.		
User-programmed Sequences	8000 steps (max.) Step time adjustable range 0.00Sec to 99,999 hours		

(8) Programming time = Command response time + Output response time. The output response time differs for different models, from 40mS ~ 200mS.

**TABLE 1-3. KLN EXT GENERAL SPECIFICATIONS (CONTINUED)**

SPECIFICATION <sup>(1)</sup>	RATING/DESCRIPTION		
	5KW	10KW	15KW
<b>PHYSICAL CHARACTERISTICS</b>			
Weight	5.7.3 lbs (26Kg) <sup>(9)</sup>	76.7 lbs (34.8 Kg) <sup>(10)</sup>	96.1 lbs (43.6 Kg) <sup>(11)</sup>
Dimensions	19" x 5.2" x 35" (482mm x 132mm x 889.5mm) See Figure 1-4		
Source Power Connector	Rear panel L1, L2, L3 terminals for 3-wire connections		
Load Connections	Rear panel ± bus bars with protective cover (supplied)		
Sense connections	Rear panel ±S terminals		
System	Rear panel connectors (2) - Ensures proper operation in parallel configurations and also used for future firmware upgrades.		
Current Share Programming	Rear panel connectors, 2-pin (2) - required for proper current sharing among parallel-connected units (two mating 2-pin pluggable terminal blocks supplied)		
Programming Sequence port	Front panel USB connector for uploading program sequences		
I/O Control port	9-pin connector for five auxiliary control functions: Interlock, external output ON/OFF, shut OFF, alarm and Output voltage downward status.		
WAN/LAN	Rear panel connectors for parallel connections.		
<b>GENERAL (ENVIRONMENTAL) SPECIFICATIONS</b>			
Temperature	Operating: Storage:	0 to 45°C (indoor use only) -20 to 70°C	
Humidity	Operating: Storage:	30%~80% RH (no condensation) Max: 80% RH up to 30°C, linear decrease to 50% RH at 40°C 10%~80% RH (no condensation)	
Altitude	2000m (6,562 ft.) max		
Cooling	Forced air by speed-controlled fan		
Noise	50 ~ 70 dB (A) (model and load dependent)		
EMC Standard	CE Mark - full compliance with LVD and EMC directives		

(9) 60.6 lbs (27.5 Kg) for KLN 80-180 models.

(10) 80.0 lbs (36.3 Kg) for KLN 80-360 models.

(11) 99.4 lbs (45.1 Kg) for KLN 80-540 models.

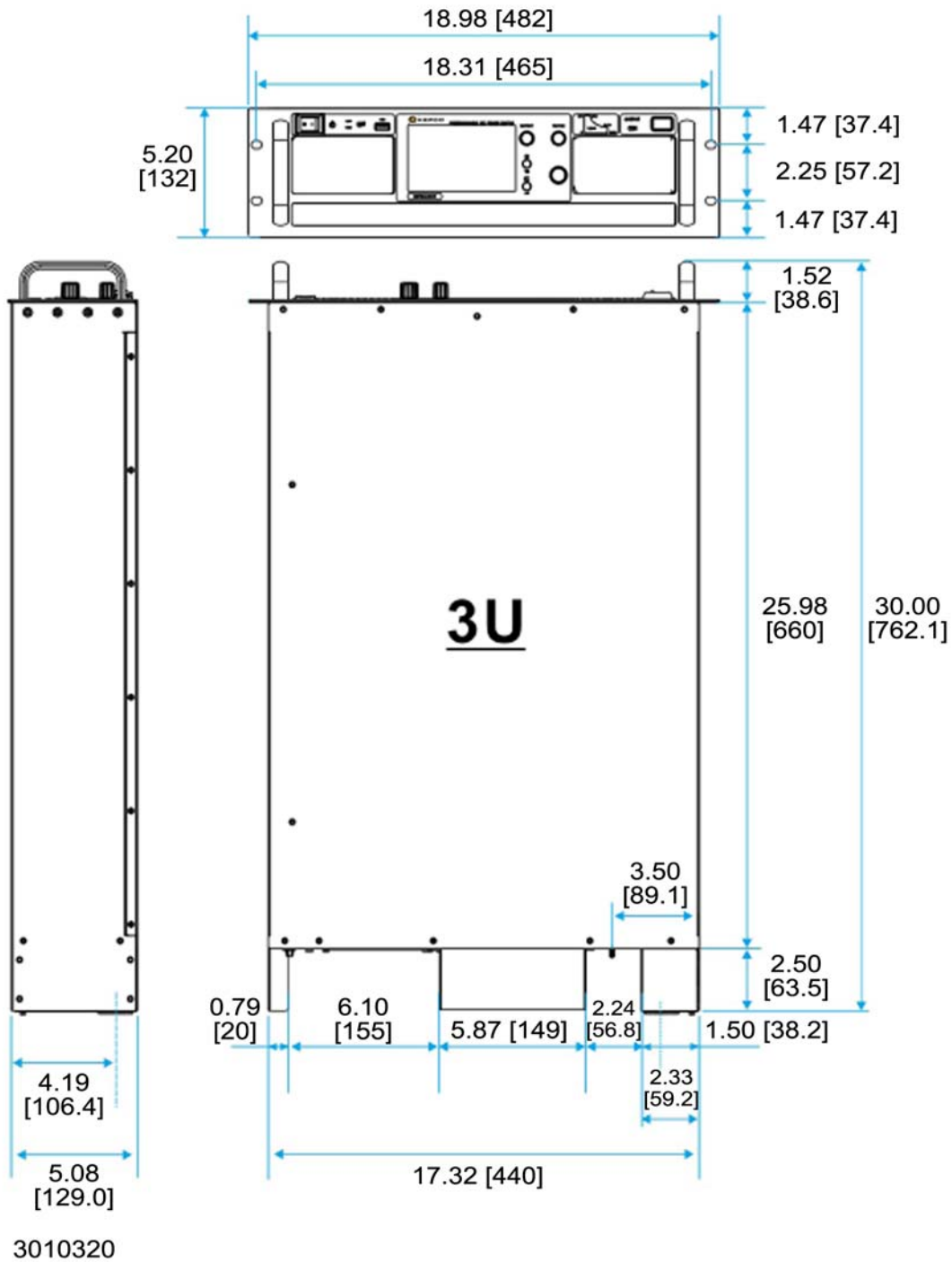

FIGURE 1-4. KLN EXT 5KW, 10KW, 15KW POWER SUPPLY, OUTLINE DRAWING



## **1.4 LOCAL CONTROL**

Local control<sup>(†)</sup> of The KLN EXT Power Supply is from the front panel, and can be done two ways: using either the touchscreen, or using the three knobs and two buttons adjacent to the touchscreen.

## **1.5 REMOTE CONTROL**

The KLN EXT Power Supply can be remotely controlled directly via the built-in LAN interface using either a browser or SCPI commands (see Appendix A and B). Most features available in local mode can also be accessed remotely.

## **1.6 AUXILIARY CONTROL**

External reference signals, provided through the Auxiliary Control port (see Table 2-2), can be used to enable the unit via an interlock, control output on/off and permit emergency shutdown of the output. Output signals allow remote monitoring of alarm conditions and when output voltage is being adjusted downward more than 1% of present value. Refer to Table 2-2 for further details on using external signals to control and monitor the output.

## **1.7 FEATURES**

### **1.7.1 DIGITAL CALIBRATION**

The KLN EXT Power Supply features high stability and long intervals between calibration. The unit contains no user-required internal adjustments. Calibration is done by means of software (see Section 4).

### **1.7.2 PROTECTION**

The following protection is provided: OVP (Overvoltage Protection), UVL (Undervoltage Limit), OCP (Overcurrent Protection), UCL (Undercurrent Limit), OPP (Overpower Protection), UPL (Underpower Limit), OTP, (overtemperature protection) and input line failure. OVP, OCP, OPP, UVL, UCL and UPL are programmable.

### **1.7.3 SAVING AND RECALLING SETTINGS**

The KLN EXT offers three memory locations accessible from the front panel<sup>(‡)</sup> that can be used to store voltage, current, power and time (time is the length of time the voltage, current and power setting is applied to the output). These operating parameters can be recalled to quickly program the unit to the predetermined setting. Refer to PAR. 3.4.2.2.1 for further details.

### **1.7.4 PARALLEL AND SERIES CONFIGURATIONS**

Identical KLN EXT units may be configured in series (up to two units including master) or parallel (up to five units including master) configurations. Parallel configurations provide for automatic current sharing (see PAR. 2.8 for details).

### 1.7.5 MISCELLANEOUS FEATURES

- Both positive and negative output ramps can be independently programmed, providing protection for the device under test (see PAR 3.4.9 and 3.4.10 for details).
- Last setting is automatically restored upon power-up. Output can be programmed to be either on or off upon power-up (see PAR's. 3.4.4).
- Front panel recall<sup>(‡)</sup> of up to 16 user-programmed sequences, each comprised of a maximum of 500 steps. Each step stores voltage, current, power and time settings (see PAR's. 3.4.2.3). Each sequence may be run either once or multiple times, and the sequence order can also be user-programmed (see PAR. 3.4.2.3.4).
- Extremely low output ripple and noise.
- 16-bit D/A conversion for setting and 24-bit A/D conversion for measurement.
- Variable speed fans reduce noise and extend fan life.
- Non-gap stacking; No ventilation holes at top or bottom.
- CE Mark approved.
- Approved as compliant to LXI Version 1.4, Device Specification 2011.

### 1.8 EQUIPMENT SUPPLIED

Equipment supplied with the KLN EXT power supply is listed in Table 1-4.

**TABLE 1-4. EQUIPMENT SUPPLIED**

ITEM	DESCRIPTION	KEPCO PART NUMBER
Input Protective Cover with mounting hardware	Used for safety protection of input connections. See PAR.2.5.3 for installation	To be Supplied (contact factory)
Output Protective Cover with mounting hardware	Used for safety protection of output connections. See PAR. 2.5.6 for installation	To be Supplied (contact factory)
Pluggable Terminal blocks	Mate with P1, P2 connectors for current sharing connections.	Kepeco P/N to be Supplied (DECA MC420-350-02G 2-pole)
9 pin D-Sub connector	Mating connector for I/O (auxiliary) control port.	To be Supplied (contact factory)
Ethernet cable (1.5m)	Provides internet connection for remote control via the LAN interface.	To be Supplied (contact factory)

## 1.9 ACCESSORIES

Accessories (not supplied) for the KLN Power Supply are listed in Table 1-5.











**TABLE 1-5. ACCESSORIES**

ITEM	FUNCTION	KEPCO PART NUMBER
Ethernet cable (1.5m)	Provides internet connection for remote control via the LAN interface.	To be Supplied (contact factory)
Side Support Bracket (pair), 14.95 in. long	Provides side support for rack-mounted units.	128-2495
L-Bracket	Used to install bus bars for parallel operation on units with horizontal output terminals	Left: 128-2496 Right: 128-2497
Bus Bar	Used to connect stacked units in parallel. 6 in parallel: 10 in parallel:	172-0680 172-0681

## 1.10 SAFETY

Service must be referred to authorized personnel. Using the power supply in a manner not specified by Kepco, Inc. may impair the protection provided by the power supply. Observe all safety precautions noted throughout this manual (see listing on Safety page A, preceding the Table of Contents). Table 1-6 lists symbols used on the power supply or in this manual where applicable.

**TABLE 1-6. SAFETY SYMBOLS**

SYMBOL	Meaning
	WARNING! RISK OF ELECTRIC SHOCK!
	CAUTION: REFER TO REFERENCED PROCEDURE.
	HAZARDOUS VOLTAGE
	FRAME OR CHASIS TERMINAL
	GROUND TERMINAL
	PROTECTIVE GROUND CONDUCTOR TERMINAL
	OFF
	ON
	DIRECT CURRENT (DC)
	ATERNATING CURRENT (AC)
	3-PHASE ATERNATING CURRENT (AC)
WARNING	IF PROCEDURE NOT FOLLOWED CORRECTLY, INDICATES THE POSSIBILITY OF BODILY INJURY OR DEATH.
CAUTION	IF PROCEDURE NOT FOLLOWED CORRECTLY, INDICATES THE POSSIBILITY OF EQUIPMENT DAMAGE.

## SECTION 2 - INSTALLATION

### 2.1 UNPACKING AND INSPECTION

This instrument has been thoroughly inspected and tested prior to packing and is ready for operation. After careful unpacking, inspect for shipping damage before attempting to operate. Perform the preliminary operational check as outlined in PAR. 2.3. If any indication of damage is found, file an immediate claim with the responsible transport service.

### 2.2 TERMINATIONS AND CONTROLS

a) Front Panel<sup>(†)</sup>: Refer to Figure 3-1 and Table 3-1.

b) Rear Panel: Refer to Figure 2-1 and Table 2-1.

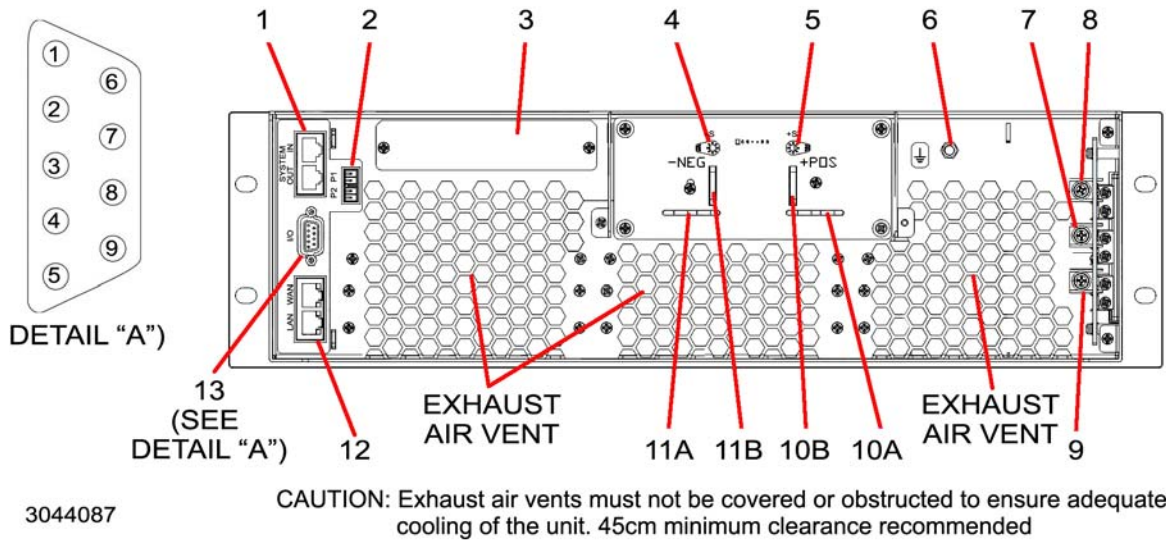

**FIGURE 2-1. KLN EXTENDED RANGE SERIES REAR PANEL**

**TABLE 2-1. REAR PANEL CONNECTOR FUNCTIONS**

NUMBER (FIGURE 2-1)	CONNECTOR/TERMINAL	FUNCTION
1	SYSTEM IN/OUT RJ 45connectors <b>CAUTION</b> These connectors <b>MUST NOT</b> be used for LAN communication	Required to synchronize units in parallel (one master, one or more slaves). SYSTEM OUT of master connected to SYSTEM IN of first slave, SYSTEM OUT of first slave connected to SYSTEM IN of second slave, etc.  Either SYSTEM IN or SYSTEM OUT can also be used to upgrade the KLN Firmware. (see PAR 3.5)
2	P1, P2 connectors	Used for current sharing when two or more units are connected in parallel. Each connector has two internal pins that are connected together. P2 of master is connected to P1 of first slave, P2 of first slave connected to P1 of second slave, etc. See PAR. 2.8.2.1 for details.
3	Option slot	Covered slot for optional interfaces: Analog, RS 422/RS485, USB, IEEE 488 (GPIB). Contact Kepeco for details.
4	-S terminal	± Sense terminals used for compensation of voltage drop on load wires: max 5V, 2.5 V per wire. Connected to corresponding ± terminal at load. <b>CAUTION: Connecting the following terminals together will damage the unit! +V to -S, -V to +S, +S to -S.</b>
5	+ S terminal	

**TABLE 2-1. REAR PANEL CONNECTOR FUNCTIONS (CONTINUED)**

NUMBER (FIGURE 2-1)	CONNECTOR/TERMINAL	FUNCTION
6	Earth ground terminal	Used for safety earth grounding of a-c mains.
7	L3 terminal	Used to connect Input a-c mains.
8	L2 terminal	
9	L1 terminal	
10	Positive (+) output terminal	Used for output connections. Fig. 2-1 items 10A and 11A show output terminals on 10KW and 15KW models with output voltage of 80V. Items 10B and 11B show output terminals on all other models.
11	Negative (-) output terminal	
12	WAN (input), LAN (out- put) RJ 45 connectors	Built-in two-port hub, eliminates the need for a extra hub when using two or more units in parallel. WAN connector: Used to connect to PC or external hub for remote control of the unit via the LAN interface. LAN connector: When using two or more units in parallel (one master plus multiple slaves), the LAN port of the master is connected to the WAN port of Slave 1, Slave 1 LAN port is connected to Slave 2 WAN port, etc. See PAR. 2.8.2.1 for details
13	I/O Auxiliary 9-pin connector	Used for auxiliary control of interlock, external remote output on-off, and shut off functions. Also allows monitoring of alarm and output voltage downward signals. See Table 2-2 for details.

**TABLE 2-2. I/O AUXILIARY PORT INPUT/OUTPUT PIN ASSIGNMENTS**

PIN (FIGURE 2-1 DETAIL A)	SIGNAL NAME	FUNCTION
1	Interlock <sup>(1)</sup>	Input signal. When shorted to Common (pins 6 through 9), the interlock is closed and the unit can operate normally. When pin 1 to common is open, the unit alarm activates (error 81) and the unit does not operate. To activate this function, refer to PAR. 3.4.14. Once the alarm activates, pin 1 must be shorted to Common to reset the unit and allow normal operation.
2	External Output ON/OFF <sup>(1)</sup>	Input signal. Provides auxiliary control of output on/off. When shorted to Common (pins 6 through 9), the output is enabled (ON). When pin 2 to common is open, the output is disabled (OFF). To activate this function, refer to PAR. 3.4.14.
3	Shut OFF <sup>(1)</sup>	Input signal. Allows the output to be disabled. When shorted to Common (pins 6 through 9), the output is disabled (OFF) and error code 82 is produced.
4	Alarm <sup>(1)</sup>	Output signal. Open collector, short when unit alarm is activated.
5	Output Voltage Downward <sup>(1)</sup>	Output signal. Open collector, short when output voltage is being adjusted downward more than 1% of present value. This can be useful if the user elects to add an external discharge circuit to the output in order to speed up fall time of the output voltage.
6, 7, 8, 9	Common	Common pin. Used for return signal.

(1): Open collector output: maximum voltage 30V, maximum current 6mA.

## 2.3 PRELIMINARY OPERATIONAL CHECK

A simple operational check after unpacking and before equipment installation is advisable to ascertain whether the power supply has suffered damage resulting from shipping.

Refer to Figure 2-1 for location of electrical connections and Figure 3-1 for location of operating controls<sup>(‡)</sup>. Table 3-1 explains the functions of operating controls/indicators. Refer to PAR. 3.2.1 for a description of basic operating techniques.

1. With power supply disconnected from source power verify that sense connections are correct: +S is connected to +POS and –S is connected to –NEG (see Figure 2.8).
2. With front panel power switch in  $\bigcirc$  position (off), connect the power supply to source power (see PAR. 2.5.2).
3. With no load connected, set power switch to  $\text{I}$  (on). Each time the unit is turned on it beeps and an internal self-test is performed ???.
4. NEED PRELIMINARY OPERATION CHECK
- 5.
- 6.
- 7.

## 2.4 INSTALLATION

### 2.4.1 INPUT WIRING

An AC Mains cable is not provided with the unit. The maximum current and recommended cross-sectional area of the conductors are listed in Table 2-3. It is recommended to keep the a-c mains cables as short as possible to keep any possible voltage drops on the cables to a minimum.

**CAUTION: IT IS ALSO REQUIRED THAT A CIRCUIT BREAKER BE INSTALLED BETWEEN THE A-C MAINS AND THE KLN EXT POWER SUPPLY (SEE TABLE 2-3).**

**TABLE 2-3. INPUT WIRING SPECIFICATIONS**

Unit Rating	5KW		10KW		15KW	
	200V	400V	200V	400V	200V	400V
Max. Current (L1)	17A	8.5A	34A	17A	52A	26A
Max. Current (L2)	17A	8.5A	34A	17A	52A	26A
Max. Current (L3)	17A	8.5A	34A	17A	52A	26A
Wire Size (L1, L2, L3, Ground)	3.5mm <sup>2</sup>	2.0mm <sup>2</sup>	8.0mm <sup>2</sup>	3.5mm <sup>2</sup>	14mm <sup>2</sup>	5.5mm <sup>2</sup>

## 2.4.2 RACK MOUNTING

KLN EXT units can be directly mounted in a standard 19-inch rack. The units are 3U high and do not require any gaps between equipment above and below. Airflow is front to back only. Side support brackets (not supplied, see Table 1-5, Accessories) are required to support the weight of the unit (see Figure 2-2).

**CAUTION:** Some models are heavier than 88 lbs (40 kg); after installing the side support brackets, two people are needed to position the unit on the brackets before securing the unit to the rack using four screws (not supplied) at the front panel.

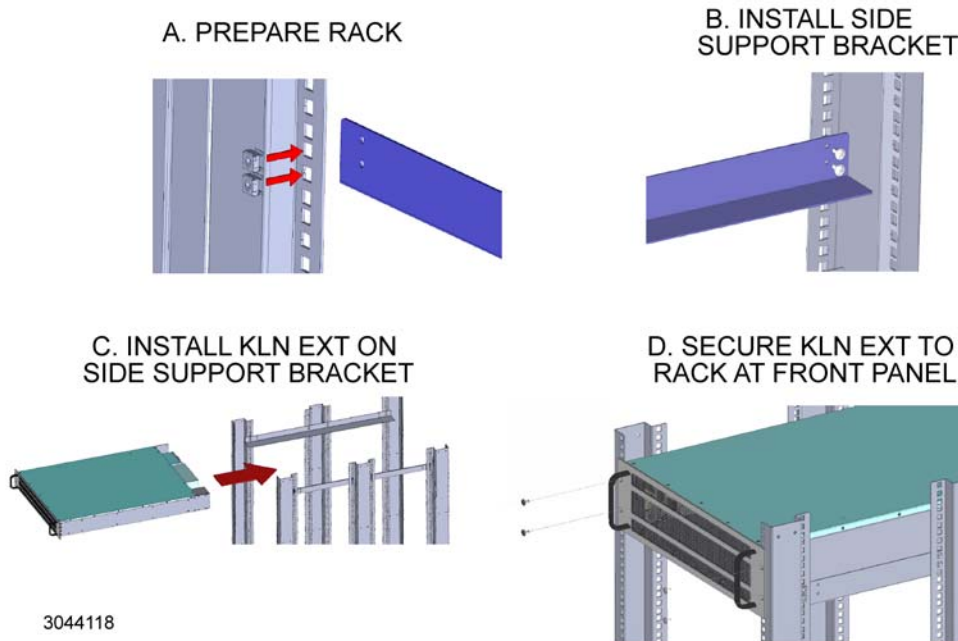

FIGURE 2-2. RACK MOUNTING

## 2.5 WIRING INSTRUCTIONS

Interconnections between an a-c power source and a power supply, and between the power supply and its load are as critical as the interface between other types of electronic equipment. If optimum performance is expected, certain rules for the interconnection of source, power supply and load must be observed by the user. These rules are described in detail in the following paragraphs.

**CAUTION:** WHEN WORKING WITH ACTIVE LOADS, THE VOLTAGE OR CURRENT OF THE ACTIVE LOAD MUST NOT EXCEED THE MAXIMUM VOLTAGE OR CURRENT RATING OF THE KLN. OTHERWISE THE OVERVOLTAGE OR OVERCURRENT PROTECTION WILL SHUT DOWN THE POWER SUPPLY.



## 2.5.1 SAFETY GROUNDING

To minimize shock hazard, the product chassis must be connected to an electrical ground. The product must be connected to the AC power supply mains through a three-conductor power cable, with the ground wire firmly connected to an electrical ground (safety ground) at the power outlet.

Local, national and international safety rules dictate the grounding of the metal cover and case of any instrument connected to the a-c power source, when such grounding is an intrinsic part of the safety aspect of the instrument. In the event that the specific installation for the power system is different from the recommended wiring, it is the user's responsibility to ensure that all applicable electric codes for safety grounding requirements are met. As a precaution, always connect the screw marked  $\text{⏏}$  at the rear panel to proper earth ground.

## 2.5.2 SOURCE POWER CONNECTIONS

Source power for all KLN EXT models is 3-phase a-c mains power. Identical phase current keeps the AC mains system balanced. Refer to Table 1-3 for nominal input voltage specifications. Accuracy can not be guaranteed when operating outside the nominal input voltage specified.

**CAUTION: DO NOT USE AN A-C SUPPLY WHICH EXCEEDS THE INPUT VOLTAGE AND FREQUENCY RATING OF THIS INSTRUMENT. THE INPUT VOLTAGE AND FREQUENCY RATING OF THE POWER SUPPLY ARE SHOWN IN TABLE 1-3. FOR SAFETY REASONS, THE MAINS SUPPLY VOLTAGE FLUCTUATIONS MUST NOT EXCEED  $\pm 10\%$  OF NOMINAL VOLTAGE.**

## 2.5.3 INSTALLING INPUT PROTECTIVE COVER.

To install the Input Protective Cover refer to Figure 2-3 and proceed as follows:

1. Ensure the cable bushings are attached firmly.
2. Pass the cables through the bushings
3. Secure the cables to the L1, L2, L3 and ground terminals as shown in Figure 2-3, Detail A.
4. Pass the earth grounding wire through the bushing and out of the protective cover.
5. Insert the hooks of the protective cover into the slots as shown, then press the cover down to fasten the cover.
6. Use two M3X8 screws to secure the cover to the chassis bracket. Verify the cover installed is installed as shown in Figure 2-3 Detail B.

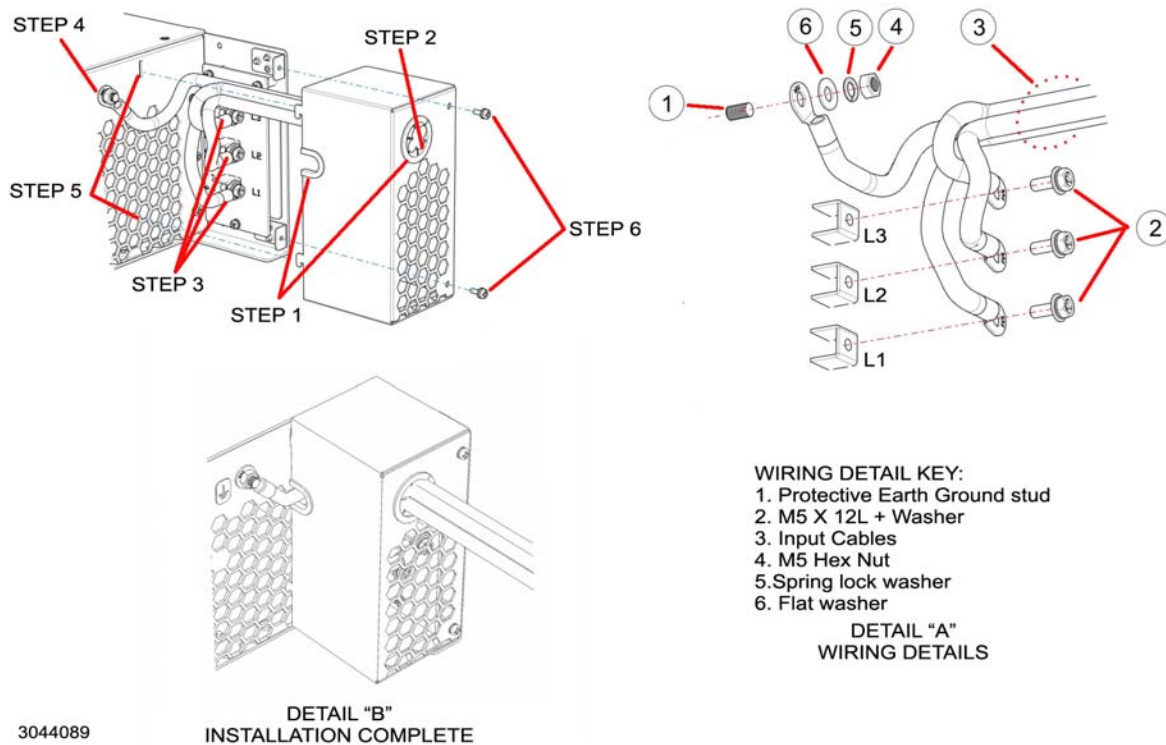

**FIGURE 2-3. INPUT WIRING AND INPUT COVER INSTALLATION**

### 2.5.4 D-C OUTPUT GROUNDING

Connections between the power supply and the load and sensing connections may, despite all precautions such as shielding, twisting of wire pairs, etc., be influenced by radiated noise, or “noise pick-up”. To minimize the effects of this radiated noise the user should consider grounding one side of the power supply/load circuit. The success of d-c grounding requires careful analysis of each specific application, however, this recommendation can only serve as a general guideline.

One of the most important considerations in establishing a successful grounding scheme is to avoid **GROUND LOOPS**. Ground loops are created when two or more points are grounded at different physical locations along the output circuit. Due to the interconnection impedance between the separated grounding points, a difference voltage and resultant current flow is superimposed on the load. The effect of this ground loop can be anything from an undesirable increase in output noise to disruption of power supply and/or load operation. The only way to avoid ground loops is to ensure that the entire output/load circuit is fully isolated from ground, and only then establish a single point along the output/load circuit as the single-wire ground point.

The exact location of the “best” d-c ground point is entirely dependent upon the specific application, and its selection requires a combination of analysis, good judgement and some amount of empirical testing. If there is a choice in selecting either the OUTPUT or COMMON output terminals of the power supply for the d-c ground point, both sides should be tried, and preference given to the ground point producing the least noise. For single, isolated loads the d-c ground point is often best located directly at one of the output terminals of the power supply; when remote error sensing is employed, d-c ground may be established at the point of sense lead attachment. In the specific case of an internally-grounded load, the d-c ground point is automatically established at the load.

The (+) and (–) terminals of KLN power supplies are d-c isolated (“floating”) from the chassis in order to permit the user maximum flexibility in selecting the best single point ground location. Care must be taken in measuring the ripple and noise at the power supply: measuring devices which are a-c line operated can often introduce additional ripple and noise into the circuit.

There is, unfortunately, no “best” method for interconnecting the load and power supply. Individual applications, location and nature of the load require careful analysis in each case. Grounding a single point in the output circuit can be of great importance. It is hoped that the preceding paragraphs will be of some assistance in most cases. For help in special applications or difficult problems, consult directly with Kepco's Application Engineering Department.

## **2.5.5 POWER SUPPLY/LOAD INTERFACE**

The general function of a voltage- or current-stabilized power supply is to deliver the rated output quantities to the connected load. The load may have any conceivable characteristic: it may be fixed or variable, it may have predominantly resistive, capacitive or inductive parameters; it may be located very close to the power supply output terminals or it may be a considerable distance away. The perfect interface between a power supply and its load would mean that the specified performance at the output terminals would be transferred without impairment to any load, regardless of electrical characteristics or proximity to each other.

The stabilized d-c power supply is definitely not an ideal voltage or current source, and practical interfaces definitely fall short of the ideal. All voltage-stabilized power supplies have a finite source impedance which increases with frequency, and all current-stabilized power supplies have a finite shunt impedance which decreases with frequency. The method of interface between the power supply output and the load must, therefore, take into account not only the size with regard to minimum voltage drop, but the configuration with regard to minimizing the impedance introduced by practical interconnection techniques (wire, bus bars, etc.). The series inductance of the load wire must be as small as possible as compared to the source inductance of the power supply: although the error sensing connection to the load compensates for the d-c voltage drop in the power leads, it cannot compensate for the undesirable output effects of the power lead inductance. These lead impedances (both power and sensing leads) are especially important if the load: is constantly modulated or step-programmed; has primarily reactive characteristics; or where the dynamic output response of the power supply is critical to load performance.

## 2.5.6 LOAD CONNECTION - GENERAL

Power connections to the load are achieved via the +POS and -NEG DC OUTPUT terminals located on the rear panel. Figure 2-4 shows the proper way to connect single or multiple loads.

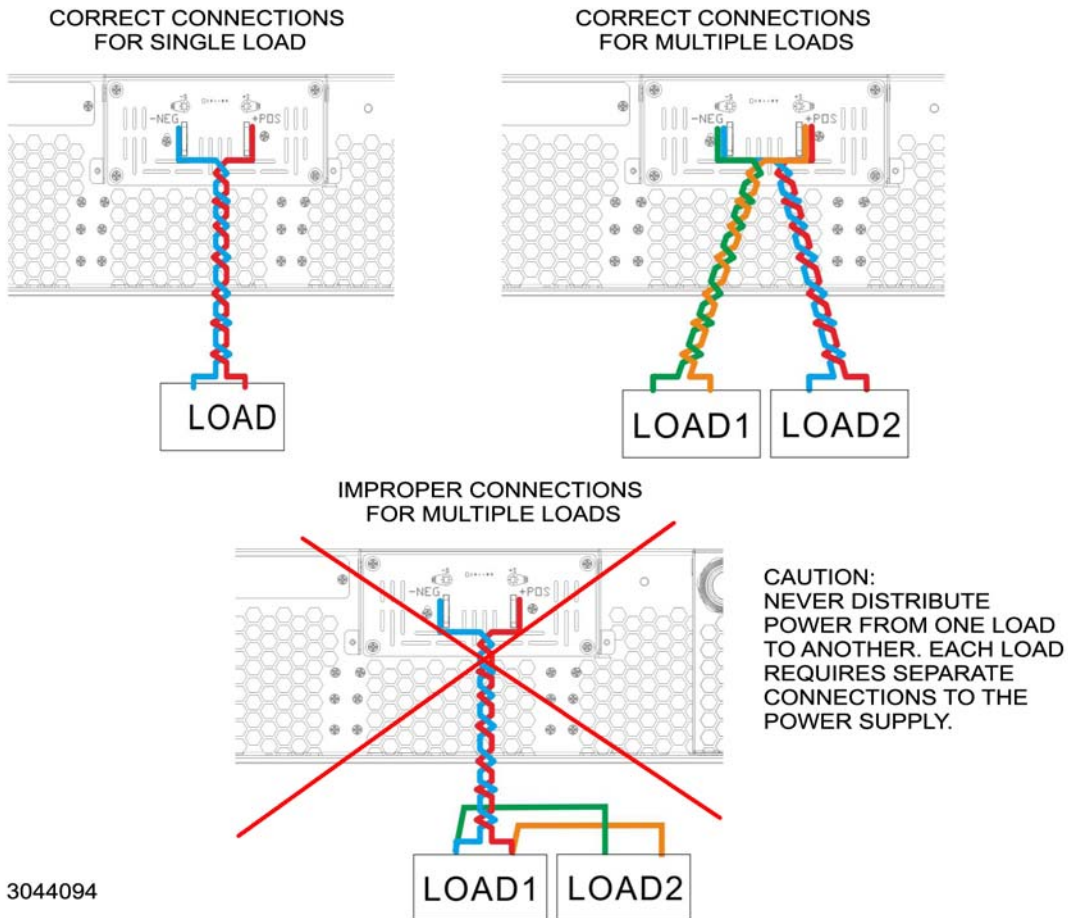

**FIGURE 2-4. CONNECTION OF SINGLE OR MULTIPLE LOADS TO OUTPUT TERMINALS**

Twist the positive and negative load wires together to reduce inductance and minimize noise pick-up from the environment. Minimize load wire impedance by using the largest diameter wire, keeping the wires as short as possible. KLN EXT use either vertical output terminals (see PAR. 2.5.6.1) or horizontal output terminals (see PAR. 2.5.6.2). Allow the cables to hang down to provide more clearance for the output terminal protective cover (see PAR. 2.5.9).

### 2.5.6.1 VERTICAL OUTPUT TERMINALS

Vertical output terminals are found on all 5KW models and on 10KW and 15KW models with output voltage higher than 80V. Dimensions for the vertical terminals are shown in Figure 2-5 and Figure 2-6 shows connection details.

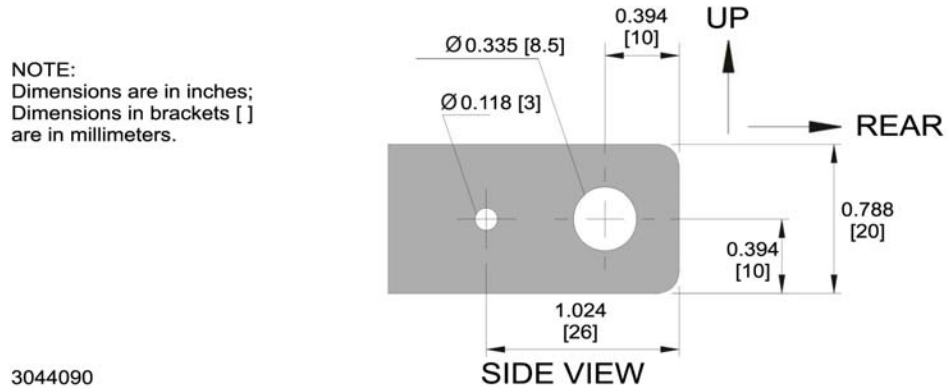

FIGURE 2-5. VERTICAL OUTPUT TERMINAL DIMENSIONS (ALL EXCEPT 5KW AND 10KW 80-VOLT MODELS)

- KEY:
1. M8 X 16L Cap Screw (recommended)
  2. Flat Washers (2 at each side)
  3. Spring Lockwasher (nut side)
  4. M8 Hex Nut
  5. Load Cable Lug
  6. Copper Output Terminal

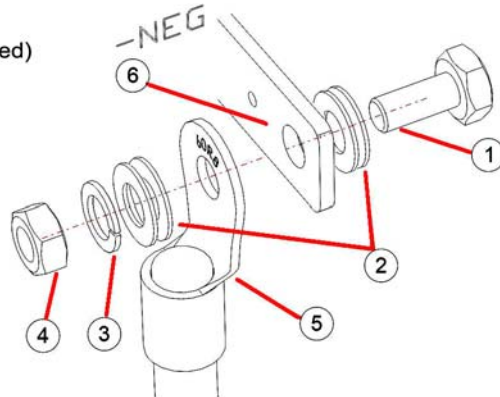

FIGURE 2-6. LOAD CONNECTION, VERTICAL OUTPUT TERMINALS, TYPICAL

### 2.5.6.2 HORIZONTAL OUTPUT TERMINALS

Horizontal output terminals are found on 10KW and 15KW models with output voltage of 80V. Dimensions for the horizontal terminals are shown in Figure 2-7 and Figure 2-8 shows connection details.

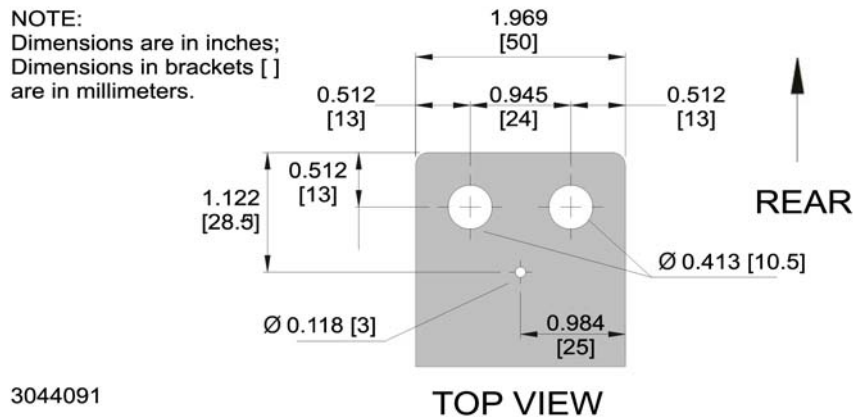

FIGURE 2-7. HORIZONTAL OUTPUT TERMINAL DIMENSIONS (10KW AND 15KW 80-VOLT MODELS)

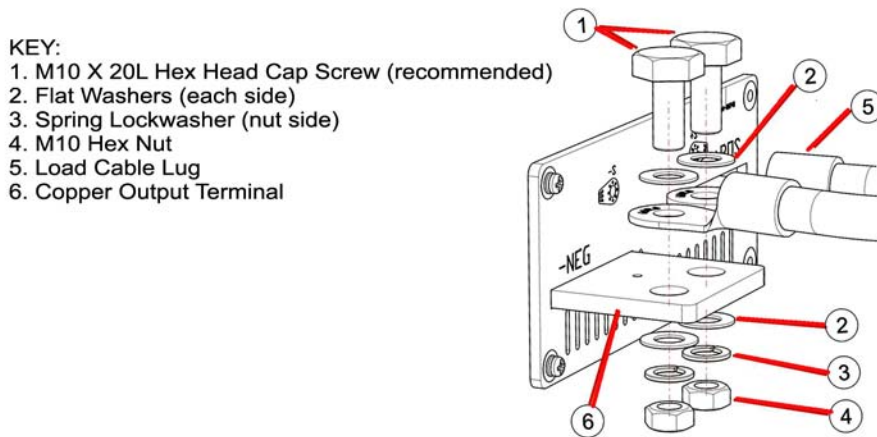
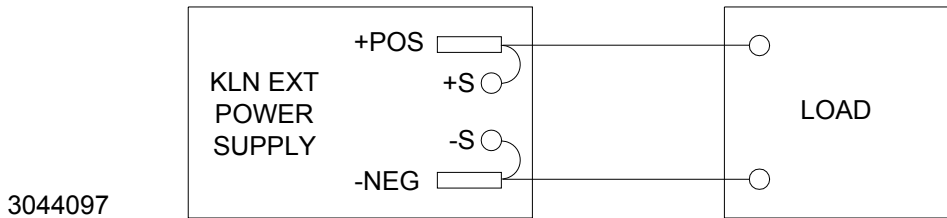

FIGURE 2-8. LOAD CONNECTION, HORIZONTAL OUTPUT TERMINALS, TYPICAL

### 2.5.7 LOAD CONNECTION USING LOCAL SENSING

Figure 2-9 shows a typical configuration using local sensing. Local sensing is recommended for a high noise or switching mode load such as d-c to d-c or d-c to a-c converter.

**CAUTION: CONNECT +S ONLY TO + POS AND -S ONLY TO - NEG. CONNECTING +S TO -S, +POS TO -S, OR -POS TO +S WILL DAMAGE THE UNIT.**



**FIGURE 2-9. LOAD CONNECTIONS, LOCAL SENSING**

**2.5.8 LOAD CONNECTION USING REMOTE SENSING**

It is recommended that output cables follow the recommendations shown in Table 2-4. If the recommended cables are unavailable, remote sensing can compensate for the voltage drop on the output cables, so the voltage at the OUTPUT terminal of the power supply is the same as the voltage at the input terminal of the load.

Figure 2-11 shows a typical configuration using remote sensing. **Both output and sense wires should be twisted together, however do not bundle the twisted output cables and twisted sense wires together.** Although the sense wires carry only a few milliamperes of current, an appropriate gauge of wire is required. Use #20 AWG wire, twisted pair for remote sense connections Use thicker cable if the length is greater than 10 meters.

Use the following formula and Figure 2-10 to calculate the voltage drop based on expected current and wire resistance. Refer to Table 2-4 for wire resistance for standard AWG sizes, as well as maximum current for power transmission at 60°C and 75°C.

$$V_{\text{DROP}} = (I \times r1) + (I \times r2)$$

where r1 and r2 is the load wire resistance

I is output current

$$\text{Voltage across Load } R_L = \text{Voltage (displayed on front panel display)} - V_{\text{DROP}}$$

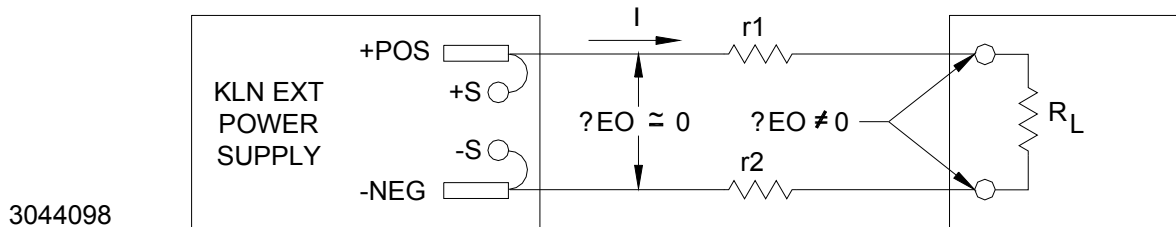

**FIGURE 2-10. LOAD WIRE VOLTAGE DROP, EQUIVALENT SCHEMATIC DIAGRAM**

**TABLE 2-4. RECOMMENDED CABLE GAUGE AND RESISTANCE BY LENGTH**

AWG SIZE	Wire Diameter	Area mm <sup>2</sup>	Resistance/Length (mOhm/m)	Maximum Current for Power Transmission (Amperes)	
				75 °C	60 °C
0000	11.684	107	0.1608	195	230
000	14.405	85.0	0.2028	165	200
00	9.266	67.4	0.2557	145	175
0	8.251	53.5	0.3324	125	150
2	6.544	33.6	0.5127	95	115
4	5.189	21.2	0.8152	70	85
6	4.115	13.3	1.296	55	65
8	3.264	8.37	2.061	40	50
10	2.588	5.26	3.277	30	35
12	2.053	3.31	5.211	20	25
14	1.628	2.08	8.286	15	20

\* Values shown are rounded up.

**CAUTION: CONNECT +S ONLY TO + POS AND -S ONLY TO - NEG. CONNECTING +S TO -S, +POS TO -S, OR -POS TO +S WILL DAMAGE THE UNIT.**

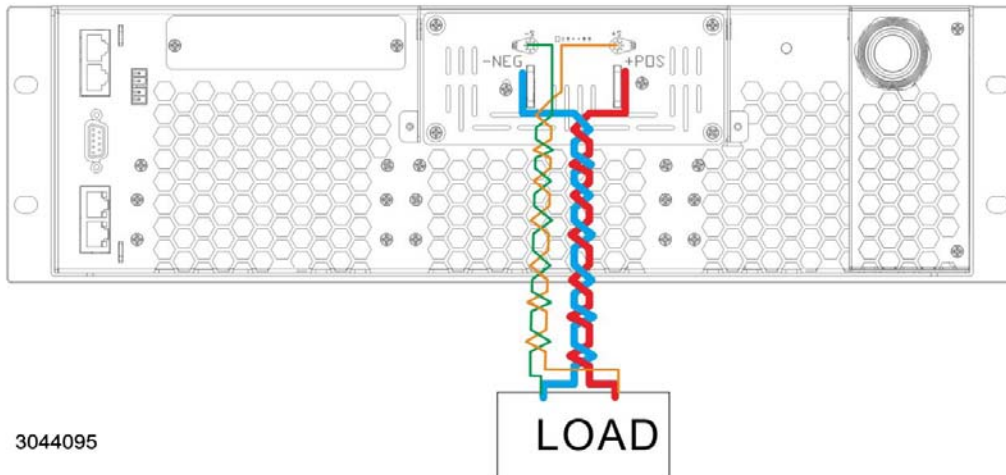
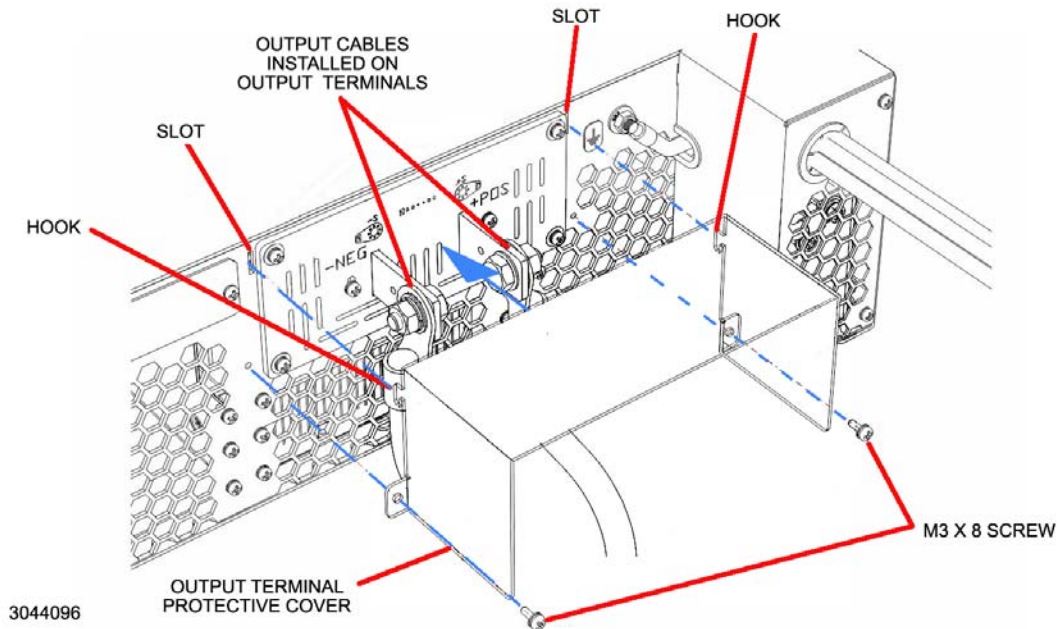

**FIGURE 2-11. LOAD CONNECTIONS, REMOTE SENSING**

**2.5.9 OUTPUT TERMINAL PROTECTIVE COVER INSTALLATION**

Complete wiring of output terminal connections before installing the output terminal protective cover. Referring to Figure 2-12, insert the protective cover hooks into the corresponding slots of the rear panel and press down to attach the cover to the panel. Then secure the protective cover to the rear panel using two M3 X 8 screws.





**FIGURE 2-12. OUTPUT TERMINALS PROTECTIVE COVER INSTALLATION**

## 2.6 LOAD PROTECTION

Depending on the type of load and how it is configured, specific protections may be required to protect the load and/or the power supply and ensure fault-free operation as explained in the following paragraph.

### 2.6.1 HIGH CAPACITANCE LOAD

Using the KLN EXT with a high capacitance load requires that a blocking diode be installed in series with the load (see Figure 2-13) in order to prevent unwanted overvoltage protection (OVP) faults.

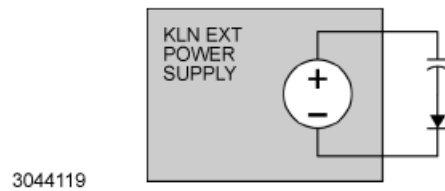

**FIGURE 2-13. USING BLOCKING DIODE WITH HIGH CAPACITANCE LOAD**

## 2.6.2 RECHARGEABLE BATTERY LOAD

Using the KLN EXT with a rechargeable battery requires that a blocking diode be installed in series with the load (see Figure 2-14). NOTE: Since the output electrolytic capacitor of the KLN EXT is fully charged, sparks may occur when connecting the power supply to the battery.

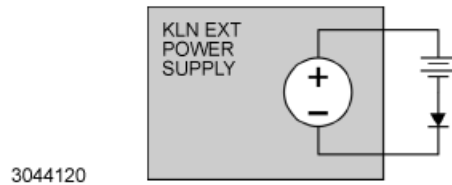

FIGURE 2-14. USING BLOCKING DIODE WITH RECHARGEABLE BATTERY

## 2.6.3 INDUCTIVE LOAD

Using the KLN EXT with an inductive load requires that a free wheel diode (D1, Figure 2-15) be installed to prevent the electromagnetic force from the power supply (generated when setting the power supply output to off) from damaging the load.

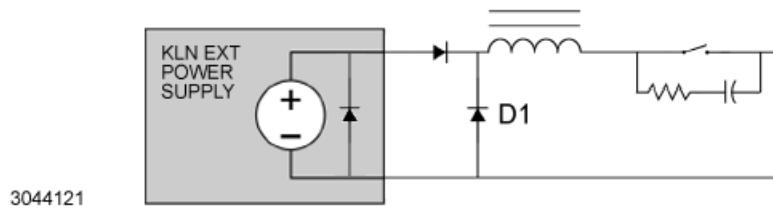

FIGURE 2-15. USING FREE WHEEL DIODE WITH INDUCTIVE LOAD

## 2.6.4 USING A MECHANICAL SWITCH TO TURN OUTPUT ON/OFF

When the KLN EXT output voltage is higher than 400V and a magnetic contactor is used as the switch to turn the output on/off, an arc may be generated. The resulting noise may enter the per supply differential amplifier and cause the output to become unstable. The noise can be absorbed by adding an RC network connected in parallel with the switch (see Figure 2-16). When using remote sensing, the sensing and power cables must be set to on or off simultaneously.

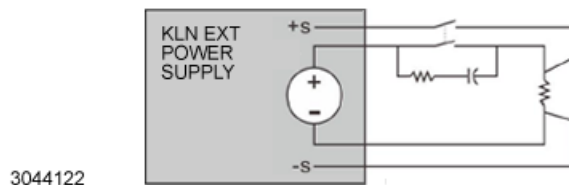

FIGURE 2-16. USING MECHANICAL SWITCH TO TURN OUTPUT ON/OFF

## 2.6.5 PWM (PULSE WIDTH MODULATED) LOAD

When connected to a PWM load (e.g, a d-c to d-c converter or d-c to a-c inverter), even though the measured current value (Mean or RMS) is lower than the rated current of the power supply, sometimes the peak value exceeds the rated current of the power supply, causing the output voltage to drop (see Figure 2-17. However, if the pulse width is narrow or the peak value is not too high, the user can reduce the peak value by installing a large capacitor at the load See Figure 2-18

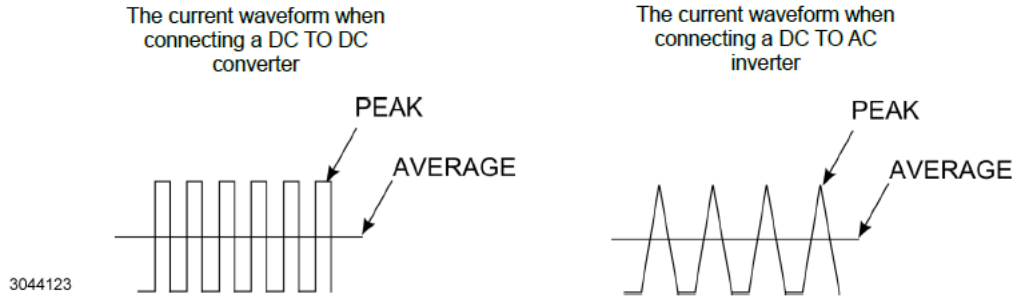

FIGURE 2-17. TYPICAL CURRENT WAVEFORMS FOR PWM LOAD

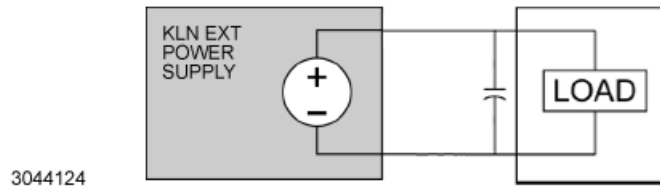

FIGURE 2-18. USING CAPACITOR WITH PWM LOAD

## 2.6.6 USING A LOAD THAT GENERATES REVERSE CURRENT

The KLN EXT power supply can not absorb reverse current from the load, so this will cause the output voltage to rise. Connect a resistor in parallel at the output to absorb the reverse current. If a large surge current is generated, also connect a capacitor in parallel (see Figure 2-19

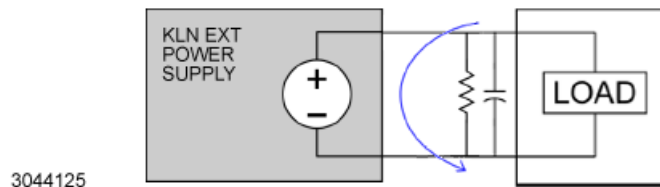

FIGURE 2-19. USING RESISTOR AND CAPACITOR TO ABSORB REVERSE CURRENT

## 2.7 COOLING

The power devices used within the power supply are maintained within their operating temperature range by means of internal heat sink assemblies and variable speed fans with air flow from front to back. Do not block the air vents at the front (intake) and rear (exhaust); 45cm clearance recommended. There are no intake or exhaust ports at the top or bottom, permitting stacked rack mounting with no air gaps between stacked units. If the power supply is located within a confined space, take care that the ambient temperature, which is the temperature of the air immediately surrounding the power supply, does not rise above the specified limits (see Table 1-3).

## 2.8 MULTIPLE UNIT CONFIGURATIONS

Parallel and series configurations of identical KLN EXT units increase the rated current or voltage range of the power supply. Up to five units (including the master) can be connected in parallel to increase the current:  $I_{MAX (one\ unit)} \times N_P = I_{MAX (parallel\ combination)}$  where  $N_P$  = number of units in parallel. Similarly, up to two units can be connected in series to increase the voltage:  $E_{MAX (one\ unit)} \times N_2 = E_{MAX (Series\ combination)}$  where  $N_2$  = number of units in series.

### 2.8.1 SERIES CONNECTIONS

Two identical KLN units can be operated in series to increase the output voltage, however master/slave control of series-connected power supplies is not supported.

**WARNING: WIRING MUST BE ACCOMPLISHED WITH UNITS DISCONNECTED FROM A-C MAINS.**

**CAUTION: A MAXIMUM OF TWO UNITS CAN BE CONNECTED IN SERIES. TO AVOID DAMAGING THE UNITS TOTAL VOLTAGE MUST NOT EXCEED:**

**80V TO 350V MODELS: 750V MAX**  
**500V MODELS: 1000V MAX**  
**650V TO 1050V MODELS: 1500V MAX**  
**1500V MODELS: 2000V**

See Figure 2-20A for series connections with local sensing or Figure 2-20B for series connections with remote sensing. See PAR. 2.5.6 for guideline regarding load connections. See PAR. 3.6.1 for instructions on operating units connected in series.

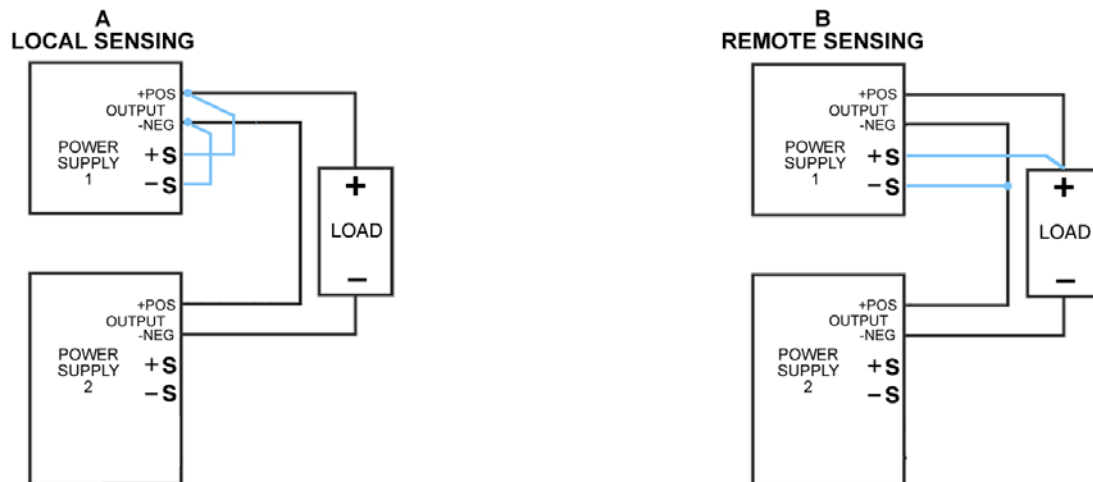

3044100

FIGURE 2-20. SERIES CONNECTIONS

## 2.8.2 PARALLEL CONFIGURATIONS

Identical KLN units (one master and up to 10 slaves) can be operated in parallel to increase the output current. Output current of the parallel combination = number of units in parallel x output current of a single unit. Maximum current is 5400 Amps.

KLN EXT power supplies' cooling air flow is from front to back. Therefore, paralleled power supplies should be stacked (not placed side by side) to reduce the length of parallel interconnections. To ensure stability do not include any equipment other than KLN EXT units in the stack. Bus bars (see Table 1-5) are available as accessories for parallel output terminal interconnections of either six or ten units; see PAR. 2-23 for installation. Units with horizontal output terminals also require installation of L-brackets (see Table 1-5) to accommodate the bus bars (see PAR. 2-23) for installation.

### 2.8.2.1 PARALLEL WIRING

Figure 2-21 shows a typical configuration for three units in parallel with remote sensing. See PAR. 2.5.6 for guidelines regarding load connections. See PAR. 3.6.3 for instructions on operating units connected in parallel. The top unit in the stack is the master. Only the sense terminals of the master are connected to the load and only the master is connected to the computer via a NIC card for remote control of the parallel-connected units.

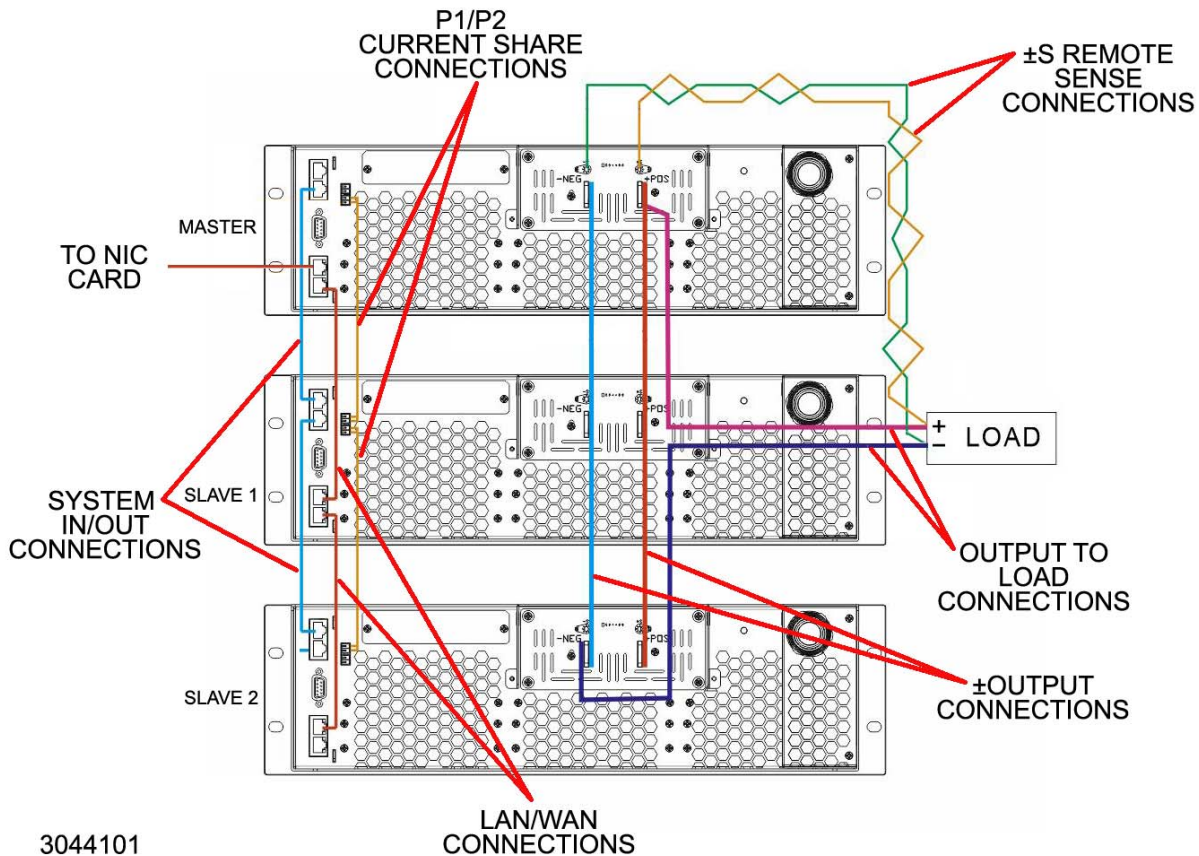

3044101

FIGURE 2-21. PARALLEL CONNECTIONS

**WARNING:** ALL UNITS MUST BE DISCONNECTED FROM A-C MAINS BEFORE CONNECTING THE UNITS IN PARALLEL.

- CAUTION:**
1. OBSERVE CORRECT POLARITY FOR ALL CONNECTIONS.
  2. IF AN ADDITIONAL CAT 5 ETHERNET CABLE IS NEEDED, A CABLE SHORTER THAN 25 CM IS RECOMMENDED.
  3. DO NOT CONNECT ANY DEVICES BETWEEN MASTER AND SLAVE.
  4. DO NOT CONNECT ANY DEVICE TO LAN OUT OF THE LAST SLAVE.
  5. DO NOT CONNECT ANY DATA-HEAVY DEVICE (E.G., DVR) TO THE PARALLEL NETWORK.
  6. TO ENSURE SIMILAR IMPEDANCES FOR LOAD CONNECTIONS, CONNECT (+) LOAD TO MASTER, (-) LOAD TO LAST SLAVE.

1. **SYSTEM IN/OUT Connections.** Connect the SYSTEM IN/OUT ports using a Category 5 ethernet cable, 25cm recommended (1 supplied with each unit, see Table 1-4, additional cables are available as optional accessories, see Table 1-5). Connect SYSTEM OUT of master to SYSTEM IN of first slave, connect SYSTEM OUT of first slave to SYSTEM IN of second slave, etc.

2. **Current Share Connections.** Connect P2 of master to P1 of first slave, connect P2 of first slave to P1 of second slave, etc. Current share wires (18AWG recommended) should be as short as possible and twisted together to reduce noise.
3. **Auxiliary I/O Connections.** If any auxiliary functions are desired (see Table 2-2), make the appropriate connections at the I/O port of the master only.
4. **LAN/WAN port connections.** For remote control of two or more units in parallel (one master plus multiple slaves), connect the LAN (output) port of the master to the WAN (input) port of Slave 1, connect Slave 1 LAN port to Slave 2 WAN port, etc. Connect the WAN (input) port of the master to the computer via a NIC card. Use Category 5 ethernet cables, 25cm recommended (1 supplied with each unit, see Table 1-4, additional cables are available as optional accessories, see Table 1-5)
5. **Output Terminal Connections.** The use of optional bus bars (see Table 1-5) for output terminal interconnections is recommended for stacking either six or ten units in parallel; see PAR. 2.8.2.3 for bus bar installation. Two bus bars in each leg can be used to accommodate excessive current. The 10KW and 15KW 80-volt models use horizontal output terminals, requiring L-brackets to be installed on the output terminals before installing the bus bars; see PAR. 2.8.2.4 for L-bracket installation.
6. **Remote Sense Connections.** Connect +S and -S to the positive and negative terminals of the load, respectively. Sense wires should be twisted together. See PAR. 2.5.8 for details regarding remote sensing.
7. **Load Cables.** Connect cables of the proper diameter from the +POS and -NEG terminals to the positive and negative input terminals of the load, respectively. Load cables should be twisted together. See PAR's. 2.5.6 and 2.5.8 for additional details regarding load cables.

#### 2.8.2.2 PARALLEL (MASTER/SLAVE) SETUP AND POWER ON/OFF SEQUENCE

After completing the wiring connections (PAR. 2.8.2.1), proceed to setup the units as follows:

1. Turn on the last slave (Slave 2 of Figure 2-21) and configure the unit as a Slave (see PAR. 3.4.3).
2. Turn on the next slave (Slave 1 of Figure 2-21) and configure the unit as a Slave. Repeat as necessary for all the slaves in the network.
3. After the last slave has been turned on and configured, turn on the master and configure the unit as a Master (see PAR. 3.4.3). NOTE: All slaves must be turned on and ready before turning on the master.

NOTE: If the power on/off order is improper, error code 85 will occur. If settings, connections or power on order are incorrect, error code 86 may occur. All slaves must be ready for use before turning on the master.

4. When powering off a parallel configuration, first power off the master, then the slaves.

NOTE: Although the master of a parallel configuration can be used independently if the slaves are not powered on, it will take longer for the unit to be ready after power on, and it is recommended that the unit be set to Independent (see PAR. 3.4.3).

### 2.8.2.3 BUS BAR INSTALLATION

Bus bars are recommended for parallel connections of stacked power supplies. Choose the proper bus bars according to the number of power supplies to be paralleled.

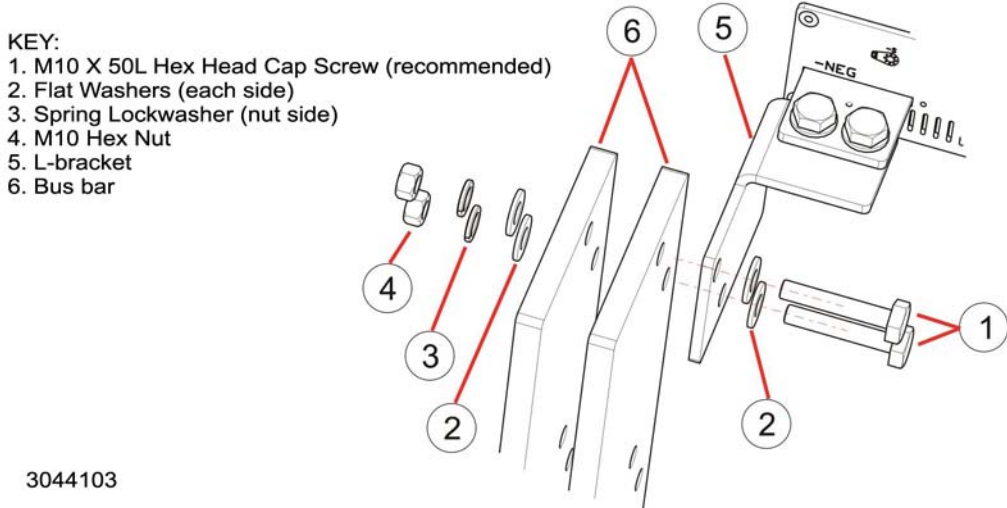

FIGURE 2-22. BUS BAR INSTALLATION

### 2.8.2.4 L-BRACKET INSTALLATION (10KW AND 15KW, 80-VOLT UNITS ONLY)

To install bus bars on units with horizontal output terminals, L-brackets (see Table 1-5) must first be installed on the output terminals as shown in Figure 2-23.



**KEY:**

- 1. M10 X 30L Hex Head Cap Screw (recommended)
- 2. Flat Washers (top and bottom)
- 3. Spring Lockwasher (nut side)
- 4. M10 Hex Nut
- 5. L-bracket
- 6. Copper Output Terminal

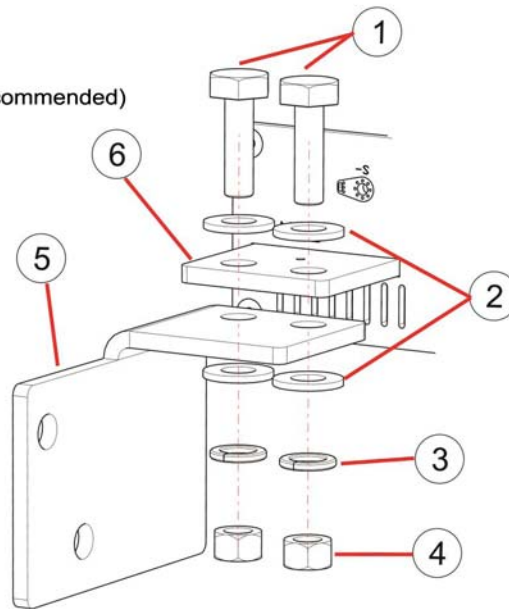

3044102

**FIGURE 2-23. L-BRACKET INSTALLATION**

## **2.9 SETTING UP THE UNIT**

The following paragraphs describe the connections and initial KLN EXT setup needed to operate in the desired mode.

### **2.9.1 SETUP FOR LOCAL OPERATION**

After connecting the unit using either local (PAR. 2.5.7) or remote sensing (PAR. 2.5.8), the unit will power up in Local mode with no further setup required.

### **2.9.2 SETUP FOR REMOTE OPERATION VIA LAN**

Connect a computer to the WAN connector at the rear panel using a standard RJ 45 Ethernet cable, CAT 5 grade or higher (supplied) per Figure 2-24. The unit automatically enters remote mode when a command is accepted. The LAN interface uses LAN Port 5025 for Telnet connections.

When connecting to the LAN with a DHCP server and DNS, the KLN EXT will obtain an IP address automatically; this will take about one minute. The IP address information can be read from the front panel (see PAR. 3.4.16.1) or a web browser (see PAR 3.8.1).

See PAR. 3.8.1 to operate the unit via the LAN interface.

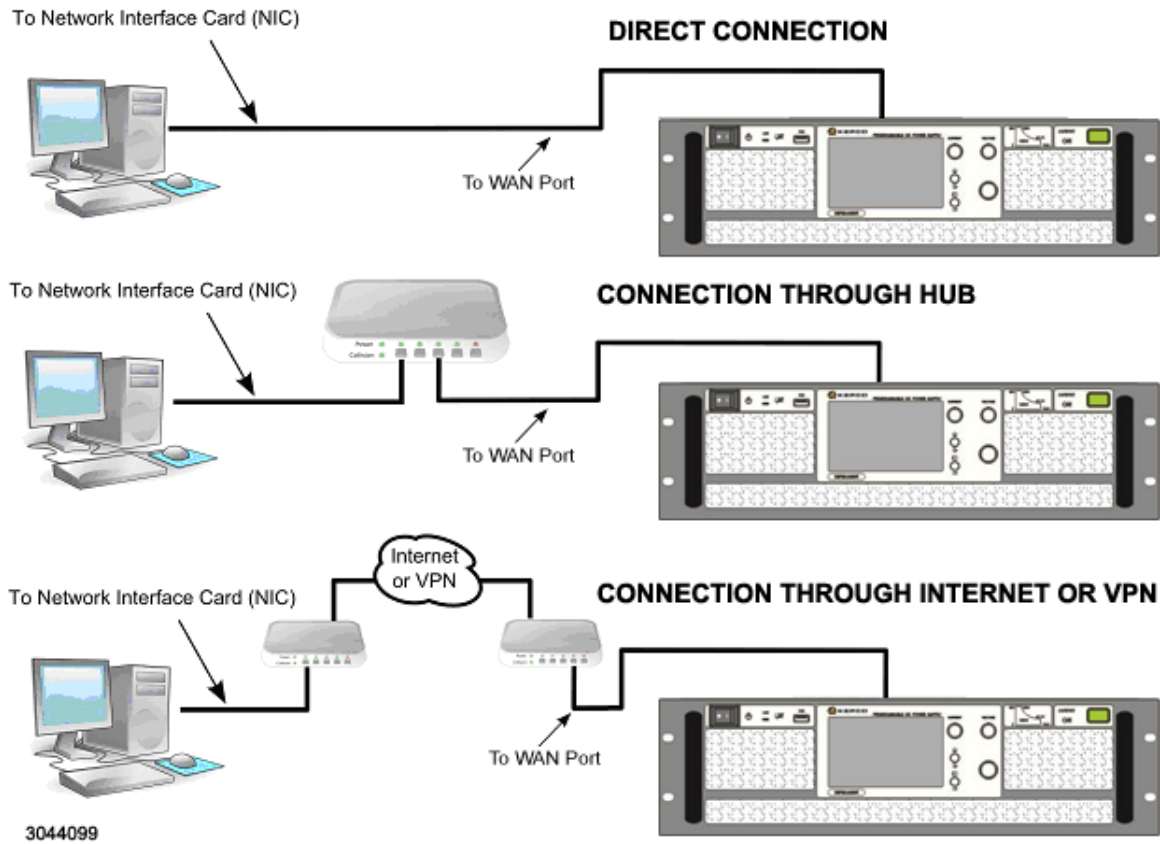

FIGURE 2-24. LAN CONNECTIONS

## SECTION 3 - OPERATION

### 3.1 GENERAL

This section explains how to operate the KLN EXT Power Supply. The power supply can be operated either in Local mode<sup>(†)</sup> (see PAR. 3.4) or in Remote mode (see PAR. 3.8.1). Local mode can be implemented using either the touch screen display or the front panel controls and switches as explained in PAR. 3.2

NOTE: Unless otherwise noted, operating instructions start from the Home screen (see Figure 3-2). Press HOME switch for at least 1.5 seconds to exit submenus and return to the Home screen.

Remote mode uses the built-in LXI-compatible LAN interface (see PAR. 3.5.6) to communicate with a remote computer. Communication is via SCPI commands which afford full functionality of the KLN EXT (see PAR. 3.6, Appendix A and Appendix B). Operation in remote mode can be simplified by the use of an IVI.COM driver.

### 3.2 POWER SUPPLY BASICS<sup>(‡)</sup>

The following paragraphs describe basic operation of the front panel controls, indicators and switches, as well as the color display/touch screen, which are used to configure and operate the power supply. This includes a description of the front panel (PAR. 3.2.1), color display/touch-screen (PAR. 3.2.2), how to turn the unit on (PAR. 3.2.3) and how to change the power-up defaults (see PAR. 3.2.1). An explanation of the KLN EXT menus (PAR. 3.2.4) provides basic techniques used to operate the power supply. Operator convenience functions (LCD background and contrast, and the audible beep) are described in PAR. 3.2.5. Refer to Table 3-1 and Figure 3-1 for a description of front panel controls and indicators. PAR. 3.3 explains how to use the front panel Menu to access all other locally accessible functions.

#### 3.2.1 FRONT PANEL CONTROLS, INDICATORS AND SWITCHES<sup>(‡)</sup>

The following paragraphs describe basic operation of the front panel controls, indicators and switches used to configure and operate the power supply<sup>(†)</sup>. Refer to Table 3-1 and Figure 3-1 for a description of front panel controls and indicators.

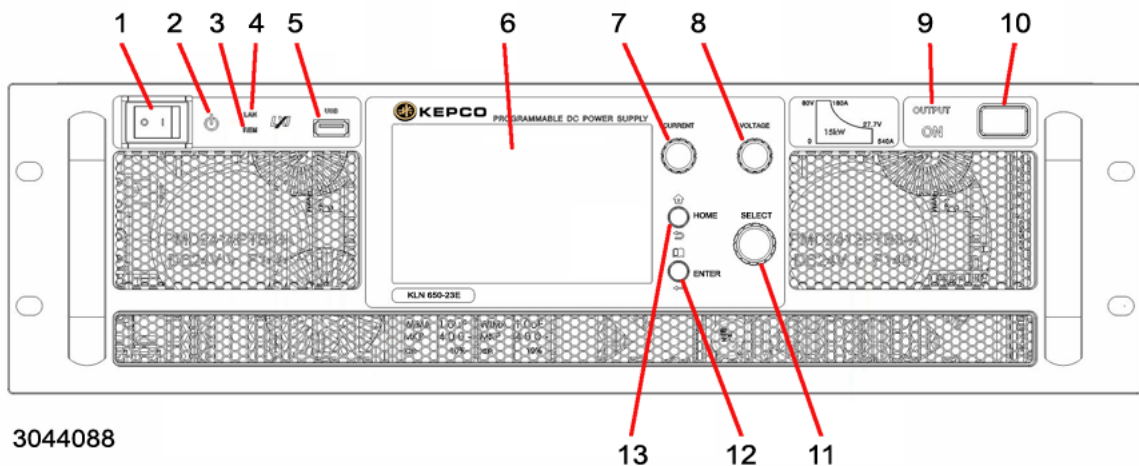

**FIGURE 3-1. KLN EXT SERIES FRONT PANEL<sup>(‡)</sup>**

**TABLE 3-1. FRONT PANEL CONTROLS AND INDICATORS<sup>(‡)</sup>**

NUMBER (FIGURE 3-1)	CONTROL/INDICATOR <sup>(‡)</sup>	FUNCTION
1	POWER switch	Used to turn power supply on or off: <b>O</b> for off, <b> </b> for on.
2	POWER ON indicator	Lights when the power supply is energized.
3	REM indicator	Lights when unit is controlled remotely.
4	LAN indicator	Lights when LAN connected successfully. Can be programmed to blink using LXI:IDEN command (see PAR. B.11)
5	USB port	Used to allow uploading of data from flash (thumb) drive (64GB max., FAT32 format). Data supported includes List Sequences (see PAR. 3.4.2.3). <b>CAUTION: Connection and power charging of portable devices is NOT supported.</b> The USB port is also used for Firmware Upgrades (see PAR. 3.5).
6	Touch screen display	Five inch high WVGA full color display with integral resistive touchscreen. Display shows selected operating parameters. Touchscreen responds to finger pressure to provide complete access to all functions. See Table 3-2 for details.
7	CURRENT control/ momentary switch	Multifunction rotary encoder with momentary-contact pushbutton switch. Tap switch to change current setting shown on display. Tap to highlight desired digit, then rotate knob to change value blinking digit. See PAR. 3.2.4 for details.
8	VOLTAGE control/ momentary switch	Multifunction rotary encoder with momentary-contact pushbutton switch. Tap switch to change voltage setting shown on display. Tap to highlight desired digit, then rotate knob to change value blinking digit. See PAR. 3.2.4 for details.
9	OUTPUT ON indicator	Indicates output status. Lights when output is on (enabled).
10	OUTPUT ON-OFF switch	Used to set output on (enabled) or off (disabled) from the front panel. This switch setting may be affected by, or may interact with, the following MENU settings: Power ON Mode (PAR. 3.4.4), Output ON priority (PAR. 3.4.5), Output Vary - Adjust (PAR. 3.4.6), Output ON ramp time (PAR. 3.4.9), and Output OFF ramp time (PAR. 3.4.10).
11	SELECT control/ momentary switch	Multifunction rotary encoder with momentary-contact pushbutton switch. Rotating the control with the Home screen showing adjusts output power. Pressing the SELECT switch for more than 1.5 seconds locks out the front panel (disables all front panel controls, switches and touch screen). Pressing the SELECT switch again for more than 1.5 seconds unlocks the front panel.
12	ENTER momentary switch	Multifunction switch. With the Home screen showing, tap the switch to enter the MENU. This switch also functions as an ENTER key when changing MENU parameters or when setting voltage, current or power.
13	HOME momentary switch	Multifunction switch. Press and hold the switch for at least 1.5 seconds to exit remote mode. This restores local mode and the display returns to the Home screen. Tap the switch briefly to return to the previous menu page.

### 3.2.2 TOUCHSCREEN DISPLAY<sup>(‡)</sup>

Table 3-2 shows the functions of all displays, indicators and pressure sensitive keys that may appear on the Home screen keyed to item numbers appearing in Figure 3-2. Note indicators are visible only as applicable. The look of the Home screen depends on the selection of Complete Mode or Simple Mode (See PAR. 3.4.2)

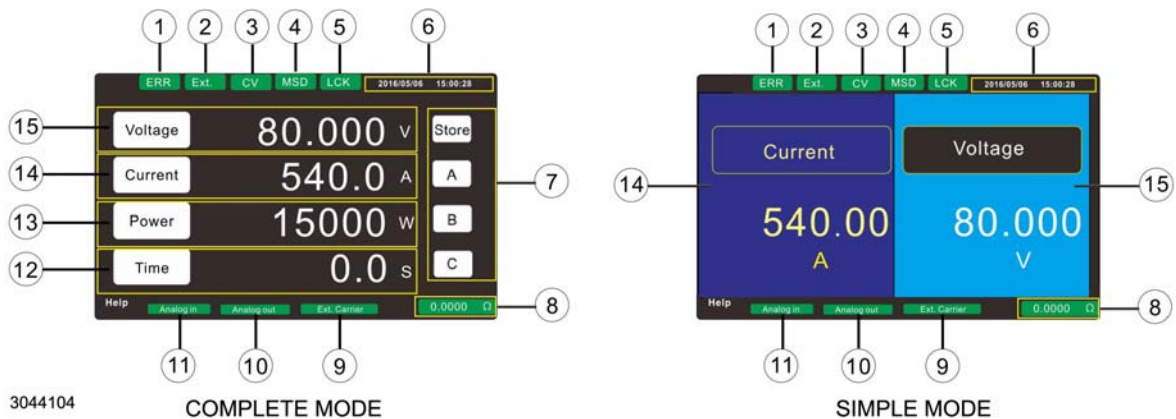

FIGURE 3-2. HOME SCREEN<sup>(†)</sup>

TABLE 3-2. TOUCHSCREEN DISPLAY<sup>(‡)</sup>

NUMBER (FIGURE 3-1)	CONTROL/INDICATOR <sup>(‡)</sup>	FUNCTION
1	ERR indicator	Visible if an error occurs. To view errors see PAR. 3.4.1 for details.
2	EXT indicator	Visible if External Output On/Off control is enabled at Auxiliary I/O port, pin 2 (See Table 2-2)
3	CV, CC, or CP indicator	Visible to show the operating mode CV (Constant Voltage), CC (Constant Current) or CP (Constant Power) when the Output is ON.
4	MSD indicator	Visible when a Memory Stick Drive (also commonly known as a flash drive or thumb drive) is inserted in the front panel USB port. See PAR. 3.4.2.3.3 for details.
5	LCK indicator	Visible when the front panel is locked. The front panel can be locked/unlocked by pressing the SELECT control for at least 1.5 seconds.
6	Date and Time indicator	Displays date and time. For adjustment see PAR's. 3.4.15.6, 3.4.15.7 and 3.4.15.8.
7	Store/Recall keys	The Store, A, B, C keys allow three settings to be stored/recalled from the front panel (see PAR. 3.4.2.2.1 for details).
8	Internal Resistance indicator	Displays selected value of internal resistance in Ohms. See PAR. 3.4.8 for details.
9	Ext. Carrier indicator	Visible when SYSTEM IN/OUT connections are in use for a parallel configuration. See PAR. 2.8.2 for details.
10	Analog Out indicator	Part of optional Analog interface currently in development.
11	Analog In indicator	Part of optional Analog interface currently in development.
12	Time key and display	Display shows the value of output time setting. The time displayed determines how long the voltage, current and power settings are available at the output once the output is set to ON (0 = continuous). The key is used to change the setting. See PAR. 3.2.7 for details.
13	Power key and display	Display shows the Constant Power setting. The key can be used to change the setting. See PAR. 3.2.6 for details.
13	Current key and display	Display shows the Constant Current setting. The key can be used to change the setting as well as Overcurrent and Undercurrent Protection settings. See PAR. 3.2.4 for details.
13	Voltage key and display	Display shows the Constant Voltage setting. The key can be used to change the setting as well as Overvoltage and Undervoltage Protection settings. See PAR. 3.2.4 for details.

### 3.2.3 TURNING THE POWER SUPPLY ON

1. To turn the power supply on, set **POWER ON/OFF** switch (1, Figure 2-1) to | (on) position. The power supply goes through a self test that exercises the Analog/Digital and Digital/Analog converters. An error 70 will be generated if the unit fails self-test.
2. See Table 3-3 for factory defaults upon initial power-up. When these settings are changed, the changed settings are saved the next time the power supply is turned on. To reload the factory defaults, refer to PAR. 3.4.19

**TABLE 3-3. FACTORY DEFAULTS**

Parameter	Factory Default	To Change default see PAR.	Access via Menu (see PAR. 3.3)
Master Slave Mode	Independent	3.4.3	B-6
Power ON Mode	OFF	3.4.4	B-7
Output ON Priority	CC	3.4.5	B-8
Output Vary - Adjust	Enter	3.4.6	B-9
Output Vary - Recall	Enter	3.4.7	B-10
Internal Resistance	0	3.4.8	B-11
Output ON Ramp Time	0	3.4.9	B-12
Output OFF Ramp Time	0	3.4.10	B-13
Voltage Slew Rate	Maximum	3.4.11	B-14
Current Slew Rate	Maximum	3.4.12	B-15
Power Slew Rate	Maximum	3.4.13	B-16
External On/Off	Disable	3.4.14	B-17-1
Interlock	Disable	3.4.14	B-17-2
ALARM buzzer	Enable	3.4.15.1	C-1
Key Beep	Enable	3.4.15.2	C-2
LCD Brightness	9	3.4.15.3	C-3
Display Color	Black	3.4.15.3	C-4
Touch Screen	9	3.4.15.3	C-5
Network Time Sync	Enable	3.4.15.3	C-6
Voltage Setting	0V	3.2.4	B-1
Current Setting	0A	3.2.4	B-2
Power Setting	0W	3.2.6	B-3
OVP (Overvoltage Protection)	110% of rated	3.2.4.1	N/A
UVL (Undervoltage Limit)	0% of rated	3.2.4.1	N/A
OCP (Overcurrent Protection)	110% of rated	3.2.4.2	N/A
OCP Delay	0.05	3.2.5	N/A
UCL (Undercurrent Limit)	0% of rated	3.2.4.2	N/A
OPP (Overpower protection)	110% of Rated	3.2.6.1	N/A
UPL (Underpower Limit)	0% of rated	3.2.6.1	N/A
Output ON Time	0	3.2.7	N/A

### 3.2.4 ADJUSTING VOLTAGE OR CURRENT (‡)

If necessary, press **HOME** switch for at least 1.5 seconds to bring up the home screen (see Figure 3-2). To adjust the value of voltage or current see either A or B below.

**A. FRONT PANEL CONTROLS.** Tap the **VOLTAGE** or **CURRENT** control (see Figure 3-1), respectively. The value for voltage or current is shown on the display. The least significant digit is blinking. Rotate the **VOLTAGE** or **CURRENT** control to change the value of the highlighted digit. Tap the respective **VOLTAGE** or **CURRENT** control to highlight the next significant digit. Repeat as needed, then tap **ENTER** to confirm or **HOME** to cancel.

**B. TOUCHSCREEN.** Touch the **Voltage** or **Current** key (or the corresponding numerical value) shown on the display (see Figure 3-3 for voltage, Figure 3-4 for current). **CV** (Constant Voltage) or **CC** (Constant Current) is highlighted in green. Touch the numerical keys on the virtual keypad shown on the display in order to change the value. Touch **ENT** (Enter) key on display to confirm, or **ESC** (Escape) to cancel.

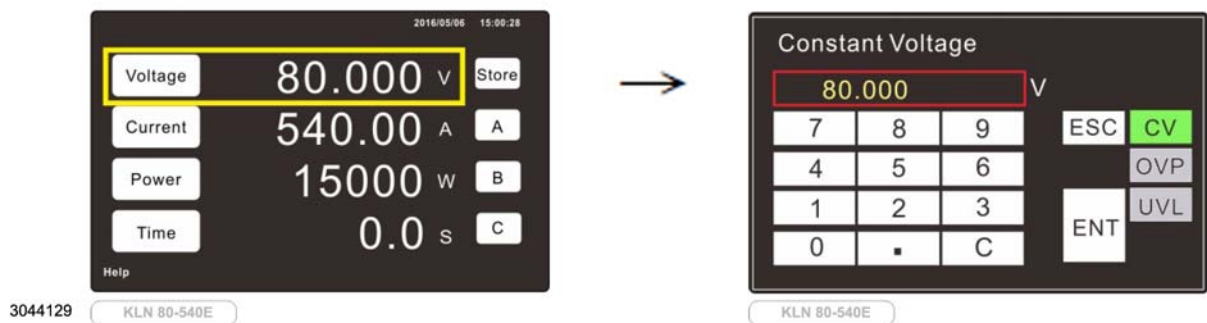

**FIGURE 3-3. TOUCHSCREEN SETTING OF VOLTAGE, OVERVOLTAGE PROTECTION AND UNDERVOLTAGE LIMIT**

#### 3.2.4.1 ADJUSTING OVERVOLTAGE PROTECTION OR UNDERVOLTAGE LIMIT(†)

Overvoltage Protection (OVP) establishes a maximum allowable value for output voltage. If output voltage exceeds the overvoltage protection value, the output is set to OFF, the background screen changes to red and an error (71 - OVP) is generated.

Undervoltage Limit (UVL) establishes a minimum allowable value for setting output voltage from the front panel only; voltage settings via SCPI commands or LAN interface are not limited. If output voltage is attempted to be programmed to be less than the UVL value, the front panel displays the OVP and UVL limits for output voltage and does not accept the setting.

If necessary, press **HOME** switch for at least 1.5 seconds to bring up the home screen (see Figure 3-3), then press **Voltage** key. **CV** is highlighted in green. To change Overvoltage Protection or Undervoltage Limit value touch the **OVP** or **UVL** key, respectively. The key changes to yellow and the **OVP** or **UVL** value is displayed. Touch the keys on the virtual keypad shown on the display in order to change the value. Touch **ENT** key on display to confirm, or **ESC** to cancel.

### 3.2.4.2 ADJUSTING OVERCURRENT PROTECTION OR UNDERCURRENT LIMIT (‡)

Overcurrent Protection (OCP) establishes a maximum allowable value for output current. If output current exceeds the overcurrent protection value, the output is set to OFF, the background screen changes to red and an error (72 - OCP) is generated.

Undercurrent Limit (UCL) establishes a minimum allowable value for setting output current from the front panel only; current settings via SCPI commands or LAN interface are not limited. If output current is attempted to be programmed to be less than the UCL value, the front panel displays the OCP and UCL limits for output current and does not accept the setting.

If necessary, press **HOME** switch for at least 1.5 seconds to bring up the home screen (see Figure 3-4), then press **Current** key. **CC** is highlighted in green. To change Overcurrent Protection or Undercurrent Limit touch the **OCP** or **UCL** key, respectively. The key changes to yellow and the **OCP** or **UCL** value is displayed. Touch the keys on the virtual keypad shown on the display in order to change the value. Touch **ENT** key on display to confirm, or **ESC** to cancel.

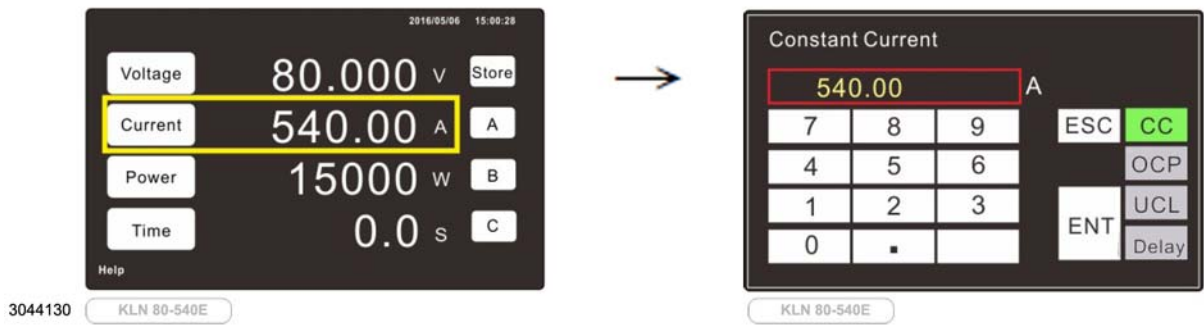

FIGURE 3-4. TOUCHSCREEN SETTING OF CURRENT, OVERCURRENT PROTECTION, UNDERCURRENT LIMIT AND PROTECTION DELAY(‡)

### 3.2.5 ADJUSTING OVERCURRENT PROTECTION DELAY(‡)

The Overcurrent Protection Delay is used to delay premature triggering of the overcurrent protection.

If necessary, press **HOME** switch for at least 1.5 seconds to bring up the home screen (see Figure 3-2), then press **Current** key. **CC** is highlighted in green (see Figure 3-4). To change Overcurrent Protection Delay touch the **Delay** key. The key changes to yellow and the Delay value is displayed. Touch the numerical keys on the virtual keypad shown on the display in order to change the value. Touch **ENT** key on display to confirm, or **ESC** to cancel.



### 3.2.6 ADJUSTING POWER<sup>(†)(‡)</sup>

If necessary, press HOME switch for at least 1.5 seconds to bring up the home screen (see Figure 3-2). To adjust the value of power\* see either A or B below.

**A. FRONT PANEL CONTROLS.** Tap the **SELECT** control (see Figure 3-1). The least significant digit of the value for power starts blinking. Rotate the **VOLTAGE** or **CURRENT** control to change the value of the blinking digit. Tap the **SELECT** control to highlight the next significant digit Repeat as needed, then tap **ENTER** to confirm or **HOME** to cancel.

**B. TOUCHSCREEN.** Touch the **Power** key (or the corresponding numerical value) shown on the display (see Figure 3-5). **CP** (Constant Power) is highlighted in green. Touch the numerical keys on the virtual keypad shown on the display in order to change the value. Touch **ENT** (Enter) key on display to confirm, or **ESC** (Escape) to cancel.

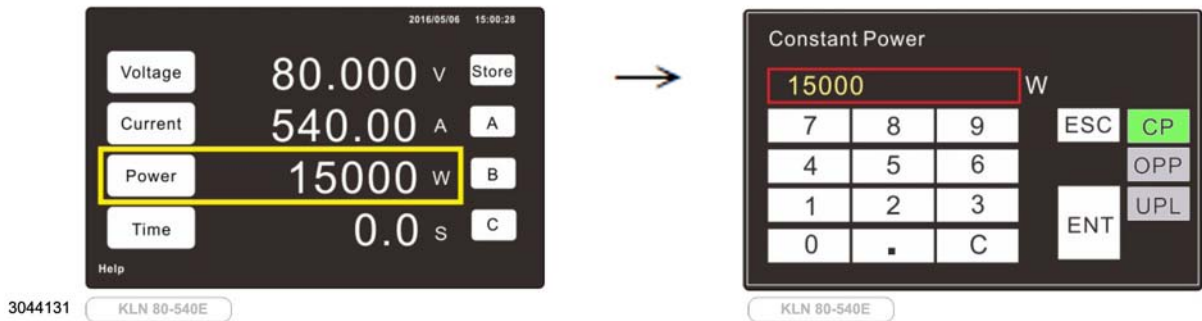

**FIGURE 3-5. TOUCHSCREEN SETTING OF POWER, OVERPOWER PROTECTION AND UNDERPOWER LIMIT<sup>(†)(‡)</sup>**

#### 3.2.6.1 ADJUSTING OVERPOWER PROTECTION OR UNDERPOWER LIMIT<sup>(‡)</sup>

Overpower Protection (OPP) establishes a maximum allowable value for output power\*. If output power exceeds the overpower protection value, the output is set to OFF, the background screen changes to red and an error (87 - OPP) is generated.

Underpower Limit (UPL) establishes a minimum allowable value for setting output power\* from the front panel only; power settings via SCPI commands or LAN interface are not limited. If output power is attempted to be programmed to be less than the UPL value, the front panel displays the OPP and UPL limits for output power and does not accept the setting.

If necessary, press **HOME** switch for at least 1.5 seconds to bring up the home screen (see Figure 3-5), then press **Power** key. **CP** is highlighted in green. To change Overpower Protection or Underpower Limit value touch the **OPP** or **UPL** key, respectively. The key changes to yellow and the **OVP** or **UVL** value is displayed. Touch the numerical keys on the virtual keypad shown on the display in order to change the value. Touch **ENT** key on display to confirm, or **ESC** to cancel.

### 3.2.7 ADJUSTING OUTPUT ON TIME<sup>(‡)</sup>

The TIME setting indicates the length of time the **Voltage**, **Current** and **Power** settings will be active. Once the output is set to ON, the time shown on the screen will count down, and be set to OFF when the count reaches zero. If **Time** is set to 0.0, the **Voltage**, **Current** and **Power** settings are continuously available until the output is set to OFF.

If necessary, press **HOME** switch for at least 1.5 seconds to bring up the home screen (see Figure 3-6). Touch the **Time** key (or the corresponding numerical value) shown on the display. Touch the numerical keys on the virtual keypad shown on the display in order to change the value. Touch **ENT** (Enter) key on display to confirm, or **ESC** (Escape) to cancel.

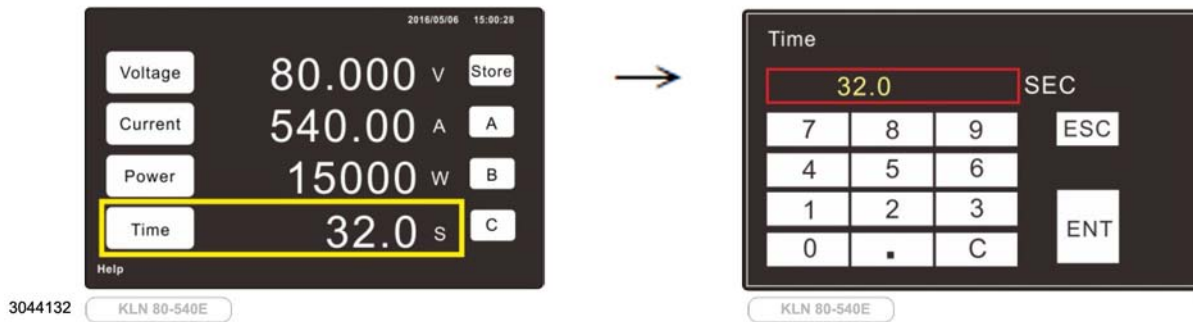

FIGURE 3-6. TOUCHSCREEN SETTING OF OUTPUT ON TIME

### 3.2.8 ENABLING/DISABLING DC OUTPUT POWER<sup>(‡)</sup>

To enable d-c output power, tap the **OUTPUT** On-Off switch (10, Figure 3-1). The output is on (enabled) when the **OUTPUT ON** indicator adjacent to the switch is lit. Tap the **OUTPUT** On-Off switch again to set the output to OFF (disabled).

### 3.3 MENU FUNCTIONS<sup>(‡)</sup>

All locally available functions of the power supply that can be accessed by the touch screen are available via the MENU<sup>(†)</sup>. If necessary, press **HOME** switch for at least 1.5 seconds to bring up the home screen (see Figure 3-2). Then tap **ENTER** to access the MENU. The complete menu structure is shown in Figure 3-7. The MENU allows the user to select various functions (see PAR. 3.3.1) and change function values (see PAR. 3.3.2).

NOTE: All functions of the power supply accessible from the front panel using the MENU can also be accomplished remotely using corresponding commands and queries listed in Appendix B.

## MENU

- |  |   |   |  |
|--|---|---|--|
| <ul style="list-style-type: none"> <li>A. Error Code</li> <li>B. Configuration           <ul style="list-style-type: none"> <li>1. Setting               <ul style="list-style-type: none"> <li>1. CV</li> <li>2. CC</li> <li>3. CP</li> <li>4. OVP</li> <li>5. OCP</li> <li>6. OPP</li> <li>7. UVL</li> <li>8. UCL</li> <li>9. UPL</li> <li>10. Time</li> <li>11. OCP Alarm                   <ul style="list-style-type: none"> <li>Delay Time</li> </ul> </li> <li>12. Recall A</li> <li>13. Recall B</li> <li>14. Recall C</li> <li>15. Store A</li> <li>16. Store B</li> <li>17. Store C</li> </ul> </li> <li>2. Operating Mode               <ul style="list-style-type: none"> <li>1. Simple Mode</li> <li>2. Complete Mode</li> <li>3. Sequence Mode</li> <li>4. Insertion Mode</li> <li>5. SAS Curve Mode (N/A)</li> <li>6. SAS Table Mode (N/A)</li> </ul> </li> <li>3. Sequence List               <ul style="list-style-type: none"> <li>1. List 1</li> <li>2. List 2</li> <li>3. List 3</li> <li>4. List 4</li> <li>5. List 5</li> <li>6. List 6</li> <li>7. List 7</li> <li>8. List 8</li> <li>9. List 9</li> <li>10. List 10</li> <li>11. List 11</li> <li>12. List 12</li> <li>13. List 13</li> <li>14. List 14</li> <li>15. List 15</li> <li>16. List 16</li> </ul> </li> <li>4. SAS Curve Paramtrs (N/A)               <ul style="list-style-type: none"> <li>1. Voc</li> <li>2. Vmp</li> <li>3. Isc</li> <li>4. Imp</li> <li>5. SAVE</li> </ul> </li> </ul> </li> </ul> | <ul style="list-style-type: none"> <li>B. Configuration (continued)           <ul style="list-style-type: none"> <li>5. SAS Scale (N/A)               <ul style="list-style-type: none"> <li>1. Voltage Scale</li> <li>2. Current Scale</li> </ul> </li> <li>6. Master Slave Mode               <ul style="list-style-type: none"> <li>1. Independent</li> <li>2. Master</li> <li>3. Slave</li> </ul> </li> <li>7. Power ON Mode               <ul style="list-style-type: none"> <li>1. Off</li> <li>2. Last</li> </ul> </li> <li>8. Output ON Priority               <ul style="list-style-type: none"> <li>1. CV</li> <li>2. CC</li> <li>3. CP</li> </ul> </li> <li>9. Output Vary - Adjust               <ul style="list-style-type: none"> <li>1. Enter</li> <li>2. Direct</li> </ul> </li> <li>10. Output Vary - Recall               <ul style="list-style-type: none"> <li>1. Enter</li> <li>2. Direct</li> </ul> </li> <li>11. Internal Resistance</li> <li>12. Output ON Ramp Time</li> <li>13. Output OFF Ramp Time</li> <li>14. Voltage Slew Rate</li> <li>15. Current Slew Rate</li> <li>16. Power Slew Rate</li> <li>17. I/O               <ul style="list-style-type: none"> <li>1. External On/Off</li> <li>2. Interlock                   <ul style="list-style-type: none"> <li>Enable</li> <li>Disable</li> </ul> </li> </ul> </li> </ul> </li> <li>C. System           <ul style="list-style-type: none"> <li>1. Alarm Buzzer</li> <li>2. Key Beep</li> <li>3. LCD Brightness</li> <li>4. Display Color               <ul style="list-style-type: none"> <li>1. White Text</li> <li>2. Black Text</li> <li>3. Green Text</li> </ul> </li> <li>5. Touch Screen</li> <li>6. Network Time Sync</li> <li>7. Calendar Setting               <ul style="list-style-type: none"> <li>1. Year</li> <li>2. Month</li> <li>3. Day</li> <li>4. Hour</li> <li>5. Minute</li> <li>6. Second</li> </ul> </li> </ul> </li> </ul> | <ul style="list-style-type: none"> <li>C. System (continued)           <ul style="list-style-type: none"> <li>8. Time Zone Setting               <ul style="list-style-type: none"> <li>1. UTC -11:00</li> <li>2. UTC -10:00                   <ul style="list-style-type: none"> <li>thru</li> </ul> </li> <li>35. UTC +14:00</li> <li>36. UTC +14:00</li> </ul> </li> <li>8. Calibration</li> </ul> </li> <li>D. LAN Setting           <ul style="list-style-type: none"> <li>1. IP Information</li> <li>2. Auto IP               <ul style="list-style-type: none"> <li>1. Enable</li> <li>2. Disable</li> </ul> </li> <li>3. Manual IP               <ul style="list-style-type: none"> <li>1. IP Address 1</li> <li>2. IP Address 2</li> <li>3. IP Address 3</li> <li>4. IP Address 4</li> <li>5. Subnet Mask 1</li> <li>6. Subnet Mask 2</li> <li>7. Subnet Mask 3</li> <li>8. Subnet Mask 4</li> <li>9. Gateway Address 1</li> <li>10. Gateway Address 2</li> <li>11. Gateway Address 3</li> <li>12. Gateway Address 4</li> <li>13. DNS Address 1</li> <li>14. DNS Address 2</li> <li>15. DNS Address 3</li> <li>16. DNS Address 4</li> <li>17. Setting Done</li> </ul> </li> <li>4. SCPI - RAW Port</li> <li>5. Message Terminator               <ul style="list-style-type: none"> <li>1. Cr</li> <li>2. Lf</li> <li>3. Cr + Lf</li> </ul> </li> <li>6. NTP Server               <ul style="list-style-type: none"> <li>1. NTP Address 1</li> <li>2. NTP Address 2</li> <li>3. NTP Address 3</li> <li>4. NTP Address 4</li> <li>5. Setting Done</li> </ul> </li> <li>7. Reset LAN               <ul style="list-style-type: none"> <li>1. Esc</li> <li>2. Reset</li> </ul> </li> </ul> </li> </ul> | <ul style="list-style-type: none"> <li>E. Optional Interface Setting           <ul style="list-style-type: none"> <li>1. Analog (N/A)               <ul style="list-style-type: none"> <li>1. Voltage Level                   <ul style="list-style-type: none"> <li>1. 5V</li> <li>2. 10V</li> </ul> </li> <li>2. Voltage Programming                   <ul style="list-style-type: none"> <li>Enable</li> <li>Disable</li> </ul> </li> <li>3. Current Programming                   <ul style="list-style-type: none"> <li>Enable</li> <li>Disable</li> </ul> </li> <li>4. Power Programming                   <ul style="list-style-type: none"> <li>Enable</li> <li>Disable</li> </ul> </li> <li>5. Monitor Output                   <ul style="list-style-type: none"> <li>Enable</li> <li>Disable</li> </ul> </li> </ul> </li> <li>2. RS422/RS485 &amp; USB               <ul style="list-style-type: none"> <li>1. RS 422/RS 485                   <ul style="list-style-type: none"> <li>1. Mode Select</li> <li>2. Address Mode                       <ul style="list-style-type: none"> <li>Enable</li> <li>Disable</li> </ul> </li> <li>3. Terminal Resistor                       <ul style="list-style-type: none"> <li>Enable</li> <li>Disable</li> </ul> </li> <li>4. Address A001 ~ A254</li> <li>5. Baud Rate                       <ul style="list-style-type: none"> <li>4800</li> <li>9500</li> <li>19200</li> <li>38400</li> <li>57600</li> <li>115200</li> </ul> </li> <li>6. Data Bit</li> <li>7. Flow Control</li> <li>8. Message Terminator                       <ul style="list-style-type: none"> <li>Cr</li> <li>Lf</li> <li>Cr + Lf</li> </ul> </li> </ul> </li> <li>2. USB                   <ul style="list-style-type: none"> <li>1. Baud Rate</li> <li>2. Data Bit</li> <li>3. Flow Control</li> <li>4. Message Terminator                       <ul style="list-style-type: none"> <li>Cr</li> <li>Lf</li> <li>Cr + Lf</li> </ul> </li> </ul> </li> <li>3. IEEE 488                   <ul style="list-style-type: none"> <li>1. Address 00 ~ 30</li> </ul> </li> </ul> </li> </ul> </li> <li>F. Information           <ul style="list-style-type: none"> <li>1. System Information</li> <li>2. Contact Us</li> <li>3. System Log</li> </ul> </li> <li>G. Load Default           <ul style="list-style-type: none"> <li>1. Esc</li> <li>2. Load</li> </ul> </li> </ul> |
|--|---|---|--|

NOTE Menu functions shown grayed out on the display are not available. Examples are Sequence List when no sequences have been loaded, an option that is not installed, or Manual IP when Auto IP is enabled.

**FIGURE 3-7. MENU STRUCTURE(‡)**

### 3.3.1 SELECTING MENU FUNCTIONS(‡)

If necessary, press HOME switch for at least 1.5 seconds to bring up the home screen (see Figure 3-2). Tap ENTER to view the top level functions of the MENU (see Figure 3-8). Note that screen selections in gray are not available; either the function is not installed (in the case of options), under development, or some condition is not met (e.g., the Sequence Mode selection (PAR. 3.4.2.3) is not available unless a memory stick with a file containing at least one pre-edited sequence is installed in the front panel USB port).

To select a function, rotate the SELECT control until the desired function is highlighted by a rectangular box, then tap either SELECT or ENTER to select the function. and proceed to the next MENU level. If desired, tap HOME to return to the previous screen. Repeat as necessary to drill down through the menu structure until the desired functions are showing The currently selected function says “Selected.” Rotate SELECT to highlight the desired function, then tap either SELECT or ENTER to confirm the selection, or tap HOME to cancel and return to the previous screen.

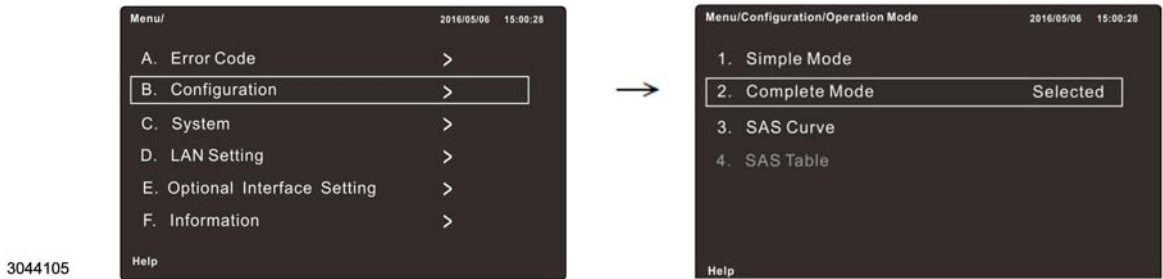

FIGURE 3-8. MENU SELECTIONS, TOP LEVEL

### 3.3.2 CHANGING MENU VALUES(‡)

When the function selected per PAR. 3.3.1 shows a value, it can be changed by tapping either SELECT or ENTER. The least significant digit of the value is then highlighted in green. Figure 3-9 shows a typical example for Output ON Ramp Time. Rotate SELECT to change the value, or tap SELECT to highlight the next digit. Continue until the value is adjusted as desired, then tap ENTER to confirm the new value, or HOME to cancel.

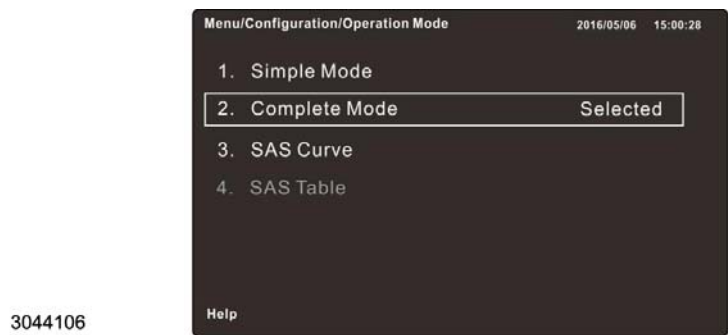

FIGURE 3-9. CHANGING VALUES, USING OUTPUT ON RAMP TIME AS EXAMPLE

### 3.4 LOCAL MODE OPERATION<sup>(†)</sup>

For Local mode operation<sup>(†)</sup>, first refer to the procedures and techniques of PAR's. 3.2, Power Supply Basics<sup>(‡)</sup> and 3.3, Menu Functions<sup>(‡)</sup>. The following paragraphs provide details of all the Menu functions shown in Figure 3-2.

NOTE: Letters and numbers indicate the Menu selection sequence required to access the function. E.g., (B-2-2) indicates selection of **B. Configuration**, then **2. Operating Mode**, then **2. Complete Mode**. Selection of functions uses the techniques described in PAR. 3.3.1. Changing of values uses the techniques of PAR. 3.3.2.

#### 3.4.1 VIEWING ERROR CODES<sup>(‡)</sup>

This function is used to determine what kind of error occurred when the ERR indicator is visible on the Home Screen (Figure 3-2). After viewing, the error code is erased. See Table B-4 for a list of possible error codes and their meaning. Access via Menu selection A.

#### 3.4.2 OPERATING MODE<sup>(‡)</sup>

There is a choice of four operating modes: simple mode, complete mode, Sequence mode, and Insertion mode, as defined in the following paragraphs.

##### 3.4.2.1 SIMPLE MODE<sup>(‡)</sup>

Simple mode causes the home screen to show only Voltage and Current as shown at the right side of Figure 3.2. Voltage and Current (PAR. 3.2.4) are adjustable. Power is set automatically to the rated maximum value. Time is set automatically to 0.0 so that Voltage and Current settings are available continuously at the output as long as the output is ON. The memory locations for storing/recalling three power supply settings are not available. Access via Menu selection B-2-1.

##### 3.4.2.2 COMPLETE MODE<sup>(‡)</sup>

Complete mode displays the complete Home screen as shown at the left side of Figure 3.2. Voltage, Current (PAR. 3.2.4), Power (PAR. 3.2.6) and Time (PAR. 3.2.7) are all adjustable. Memory locations are available to store three sets of power supply settings (voltage, current, power, time) for later recall (PAR. 3.4.2.2.1). Access via Menu selection B-2-2.

##### 3.4.2.2.1 STORE/RECALL OF MEMORY LOCATIONS<sup>(‡)</sup>

The Store/Recall key is an alternate action key, When **Recall** is visible, touch once to change it to **Store**. When **Store** is visible, touch once to change it to **Recall**.

**STORE:** With the Home screen (Complete Mode) displayed (Figure 3-2, left side), set the desired values for voltage, current, power and time. With the **Store** key visible, touch the **A**, **B** or **C** key to store the settings. The **A**, **B** or **C** key that is touched momentarily changes to a red background to indicate the settings were stored. Touch the blue **Store** key to change it back to **Recall**.

**RECALL:** With the Home screen (Complete Mode) displayed, and the **Store** key visible, touch the **A**, **B** or **C** key. The screen shows the stored settings for Voltage, Current and Power. Touch the **OK** key to recall the settings or touch the **CANCEL** key to cancel the recall.

### 3.4.2.3 SEQUENCE MODE<sup>(†)</sup>

Sequence Mode allows executing repeatable programs that are loaded when needed. When Sequence Mode is selected, the power supply looks for a preprogrammed sequence file that was stored on a memory stick and inserted into the USB port on the front panel. Once the sequence file uploads properly, each time the output is turned on, the programmed sequence will run, then stop with the output turned off. When in sequence mode, normal front panel control of the output is disabled. Only the preprogrammed sequences can be run.

Each step of a sequence configures voltage, current, power and time. Each sequence can contain a maximum of 500 steps. A maximum of 16 separate sequences are allowed, for a total of 8000 possible steps.

The first two lines define the name of the sequence (sequence01 through sequence16), the end step (the last step of the sequence) and the loop number (how many times the sequence is to be repeated before moving on).

Each step sets voltage, current and power settings and defines how long it will take to reach these settings. There are two ways to set up sequences locally, either using a spreadsheet and saving the result as a .CSV file, or using a text editor to create the .CSV file directly (see PAR 3.4.2.3.1). Sequences can also be set up and executed remotely using SCPI commands; see PAR B.53 through B.75 for details. After the sequences have been created, refer to PAR. 3.4.2.3.2 for instructions to enter sequence mode, and to PAR. 3.4.2.3.3 for instructions on how to execute the sequences.

- Create the sequence file (see PAR. 3.4.2.3.1)
- Enter Sequence Mode (see PAR. 3.4.2.3.2)
- Run the Sequence (see PAR. 3.4.2.3.3)

#### 3.4.2.3.1 CREATING THE SEQUENCE FILE

Any spreadsheet (e.g., Microsoft Excel) can be used to create a sequence file as long as the output can be saved in CSV format. Space, Tab, Semicolon, Comma, or Colon can be used to separate fields. The .CSV file can also be produced manually using a text editor (e.g., Notepad++) to create the CSV file by typing the information directly, while maintaining the proper CSV format described below.

**Example 1.** Figure 3-10 shows a properly formatted spreadsheet at the left used to generate a .CSV file shown at the right. Example 1 creates a single sequence called sequence01 that has 4 steps. Referring to Figure 3-11, when the output is turned on, output voltage rises to 20V in 0.001 second (step 1) and stays at 20V for 5 seconds (step 2), then drops to 10V in 0.001 second (step 3), then stays at 10V for 5 seconds. Since the loop number is 2, when the output is turned on, the output will produce two cycles of a 50% duty cycle square wave that goes between 20V to 10V, then the output goes off. The link list causes sequence01 to run once then stop.

	A	B	C	D	E
1	name	end step	loop number		
2	sequence01	4	2		
3	voltage	current	power	time	
STEP 1 →	4	20	0	5000	0.001
	5	20	0	5000	5
	6	10	0	5000	0.001
STEP 4 (LAST STEP) →	7	10	0	5000	5
	8	link list			
	9	1			
	10	0			
3044107	11				

name,end step,loop number,
sequence01,4,2,
voltage,current,power,time
20,0,5000,0.001
20,0,5000,5
10,0,5000,0.001
10,0,5000,5
link list,,,
1,,,
0,,,

**Spreadsheet format** **.CSV Format**

**FIGURE 3-10. SEQUENCE EXAMPLE 1, FORMAT FOR A SINGLE SEQUENCE**

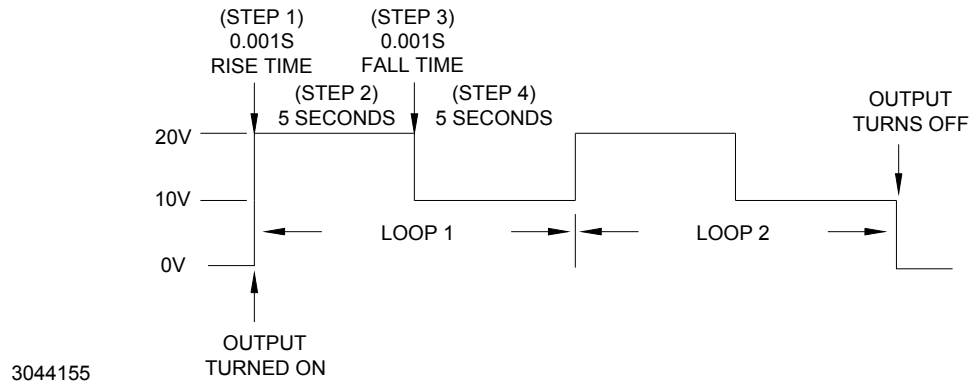

**FIGURE 3-11. SEQUENCE EXAMPLE 1, POWER SUPPLY OUTPUT**

**Example 2.** Figure 3-12 shows the spreadsheet and resulting .CSV file for two sequences, sequence01 and sequence02. Sequence01 is the same as for example 1. Sequence02 produces a more complicated waveshape. Referring to Figure 3-13, when the output is turned on, the output rises to 25V in 2.5 seconds (step 1), falls to 15V in 2.5 seconds (step 2), falls to 10V in 2.5 seconds, and falls to 0 in 2.5 seconds. The link list causes sequence02 to be run twice, then sequence01, then stop.

	A	B	C	D	E
1	name	end step	loop number		
2	sequence01	4	1		
3	voltage	current	power	time	
4	20	0	5000	0.001	
5	20	0	5000	5	
6	10	0	5000	0.001	
7	10	0	5000	5	
8	name	end step	loop number		
9	sequence02	4	1		
10	voltage	current	power	time	
11	25	0	5000	2.5	
12	15	0	5000	2.5	
13	10	0	5000	2.5	
14	0	0	5000	2.5	
15	link list				
16	2				
17	2				
18	1				
19	0				
20					

```

name,end step,loop number,
sequence01,4,1,
voltage,current ,power,time
20,0,5000,0.001
20,0,5000,5
10,0,5000,0.001
10,0,5000,5
name,end step,loop number,
sequence02,4,1,
voltage,current ,power,time
25,0,5000,2.5
15,0,5000,2.5
10,0,5000,2.5
0,0,5000,2.5
link list,,,
2,,,
2,,,
1,,,
0,,,

```

3044108

**Spreadsheet format**

**.CSV Format**

**FIGURE 3-12. SEQUENCE EXAMPLE 2, FORMAT FOR TWO SEQUENCES**

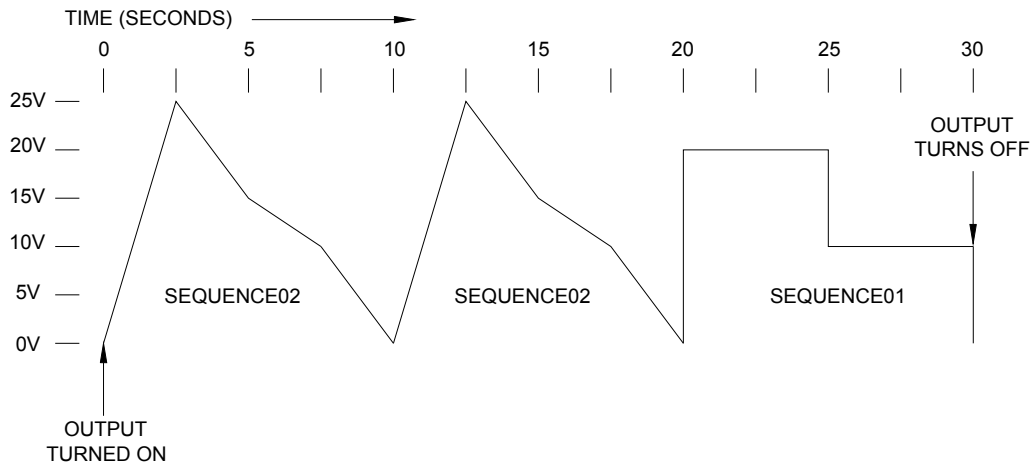

3044156

**FIGURE 3-13. SEQUENCE EXAMPLE 2, POWER SUPPLY OUTPUT**



The following steps explain the formatting rules in detail.

1. Format the each sequence as follows:
  - a. First row: Enter data in column A, B and C, exactly as shown below  
column A: name  
column B: end step  
column C: loop number
  - b. Next row: Enter the sequence parameters as defined by the headings of the previous row:  
column A: **sequenceNN** [this is the name of the sequence, where NN is a number from 01 to 16]  
column B: **X** [X represents the end step number, the last step of the sequence]  
column C: **Y** [Y represents the loop number, i.e., the number of times the entire sequence is to be repeated before either moving to the next sequence, or stopping if there are no more sequences to be executed.
  - c. Next row. Enter data in column A, B, C and D, exactly as shown below:  
column A: voltage  
column B: current  
column C: power  
column D: time
  - d. Next Row. This is the first step of the sequence. Enter the sequence parameters as defined by the headings of the previous row:  
column A: **V** [V represents the voltage value for the step]  
column B: **C** [C represents the current value for the step]  
column C: **P** [P represents the power value for the step]  
column D: **T** [T represents the time it will take to reach the values listed in columns A, B and C of this row. Note that in the example shown in Figure 3-10, the first step programs 20V (starting from 0V once the output is turned ON) in 0.001 seconds)
  - e. Next Row. This is the next step of the sequence. Enter the sequence parameters for this step:  
column A: **V** [V represents the voltage value for the step]  
column B: **C** [C represents the current value for the step]  
column C: **P** [P represents the power value for the step]  
column D: **T** [T represents the time it will take to reach the values listed in columns A, B and C of this row. Note that in the example shown in Figure 3-10, step 2 programs 20V (starting from 20V) to last for 5 seconds)
  - f. Next Row. Repeat step e above until all the steps have been entered. A maximum of 500 steps are allowed for each sequence.
2. To add another sequence, repeat step 1, changing the name to sequence02 for the second sequence, sequence03 for the third sequence, etc. A maximum of 16 sequences are allowed.
3. In the next row after the last step of the last sequence, start the link list to determine which sequences are run, and in what order. First, enter data in column A exactly as shown below:  
column A: link list  
columns B, C and D are blank.

4. In subsequent rows, enter the sequence numbers in column A in the order the sequences are to be executed (columns B, C and D are blank). For example, to run a single sequence as shown in Example 1 of PAR. 3.4.2.3.1, enter 1 for sequence01. Enter 0 in the next row to end the link list. See example 2 of PAR. 3.4.2.3.1 to run multiple sequences. Sequences can be run in any order, and can be repeated multiple times as needed, however the maximum number of rows with sequence numbers that can be executed is 16.

NOTE: Once Sequence Mode has been entered and the sequences have been uploaded to the power supply, the order of execution can be changed from the front panel (see PAR. 3.4.2.3.4).

5. When the spreadsheet is complete, save the sequence file in CSV format. If creating the sequence file using a test editor, save the file with a .CSV extension. The result will look similar to the example shown in Figure 3-10 at the right. The filename must be English characters and not exceed 16 characters. Once the file is created, proceed to PAR. 3.4.2.3.3 to upload the sequences to the power supply.

### 3.4.2.3.2 HOW TO ENTER SEQUENCE MODE<sup>(†)</sup>

1. Transfer the CSV file (see PAR. 3.4.2.3.1) to a memory stick, then insert the memory stick into the USB port on the front panel.
2. From the home screen, tap ENTER switch to access the menu, then select Sequence Mode via Menu selection B-2-3. The sequence(s) will be uploaded to the power supply automatically. If the memory stick with the sequence file is not installed in the USB port at the front panel when sequence mode is selected, the screen reads "Read Sequence Error- Can not Open File." If that is the case, touch the **OK** key, insert the memory stick in the USB port and repeat this step.

NOTE: To resume normal control of the power supply it is necessary to restore Complete Mode (Menu selection B-2-2) or Simple Mode (Menu selection B-2-1).

3. After the sequence file is loaded, it is possible to change the sequence order by selecting Sequence List from the menu. Access via Menu selection B-3 (see PAR. 3.4.2.3.4).

NOTE: If the power supply is turned off, the sequence file must be uploaded again.

### 3.4.2.3.3 HOW TO EXECUTE SEQUENCE(S) AFTER UPLOADING(†)

1. After entering Sequence Mode (PAR. 3.4.2.3.2), press HOME for at least 1.5 seconds to return to the Home screen, which will be modified as shown in Figure 3-14 to show the starting sequence, step and loop number with voltage, current and power at 0.



FIGURE 3-14. HOME SCREEN AFTER UPLOADING SEQUENCE FILE(‡)

2. Press **Output ON** switch on the front panel to execute the sequence(s). The voltage current and power displays show sequence, step and loop numbers as well as the voltage, current and power settings as each step is executed (see Figure 3-15). To temporarily pause execution of the sequence touch the **PAUSE** key on the screen. To resume execution, touch the **RUN** key on the screen. Setting the Output to OFF using the front panel **OUTPUT** on-off switch stops execution of the sequence.

NOTE: After the sequence file is loaded, it is possible to change the sequence order by selecting Sequence List from the menu. Access via Menu selection B-3 (see PAR. 3.4.2.3.4).

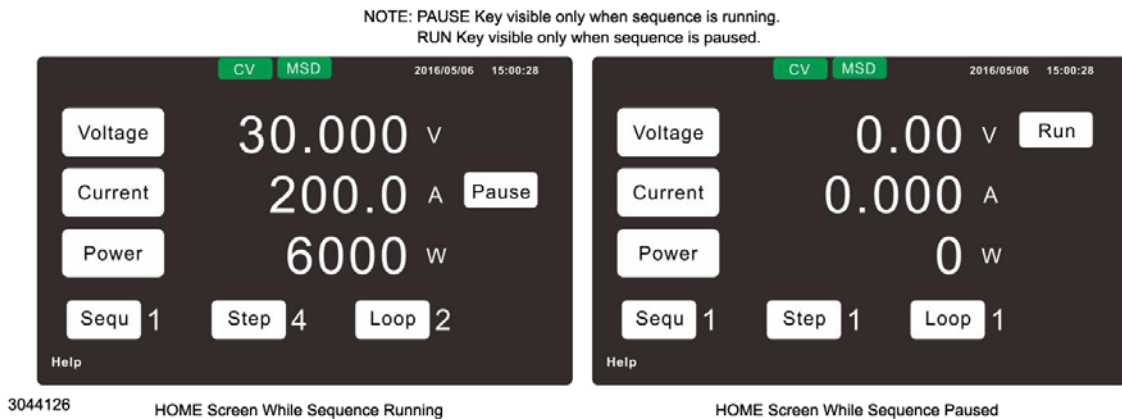

FIGURE 3-15. HOME SCREEN SHOWING SEQUENCE RUNNING AND PAUSED(‡)

### 3.4.2.3.4 SEQUENCE LIST<sup>(†)</sup>

The sequence list shows the order of execution for the sequences previously loaded when entering Sequence Mode (see PAR. 3.4.2.3.2). Access via Menu selection B-3.

### 3.4.2.4 INSERTION MODE<sup>(‡)</sup>

Insertion Mode is similar to Sequence mode (PAR. 3.4.2.3), except the sequence is initiated while the output is ON and voltage, current and power settings are already in effect. After running the inserted sequence(s) the settings in effect before the sequence(s) started are restored

To enter insertion mode, first create a sequence file (PAR. 3.4.2.3.1), then follow the instructions of PAR. 3.4.2.3.2 except select Insertion Mode (Menu selection B-2-4) instead of Sequence mode (Menu selection B-2-3)

1. Press **HOME** for at least 1.5 seconds to return to the Home screen, which will be modified as shown in Figure 3-16 to show the starting sequence, step and loop number with Output ON and existing voltage, current and power settings still in effect. Three additional keys are displayed on the screen:
  - The **RUN** key initiates the inserted sequence(s) immediately following the completion of the settings in effect when **RUN** is pressed.
  - The **PAUSE** key pauses the sequence. The output goes to 0V, 0A, 0W while pause is in effect. Touch the **RUN** key to continue the sequence.
  - The **STOP** key stops the sequence and restores the settings in effect before the sequence started. Once **STOP** key is pressed, **RUN** key restarts the sequence from the beginning.

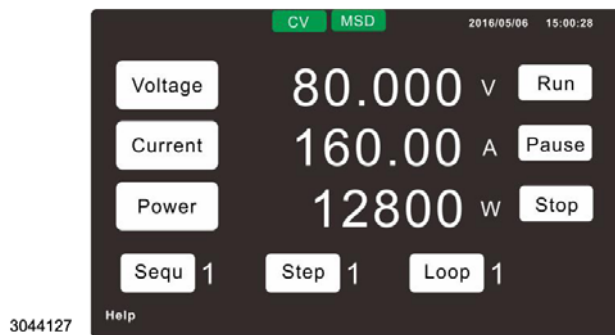

FIGURE 3-16. HOME SCREEN WHEN INSERTION MODE SELECTED<sup>(‡)</sup>

### 3.4.3 MASTER/SLAVE MODE<sup>(‡)</sup>

This configures the unit to operate as either an independent unit, a master in a parallel configuration or a slave in a parallel configuration. Access via Menu selection B-6.

**Independent:** Sets the power supply to be used independently. Access via Menu selection B-6-1.

**Master:** Sets the power supply to be a Master in a Master/Slave parallel configuration All setting, readback and control is via the Master. Refer to PAR. 2.8.2 for details of parallel configurations. Access via Menu selection B-6-2.

**Slave:** Sets the power supply to be a Slave in a Master/Slave parallel configuration Refer to PAR. 2.8.2 for details of parallel configurations All setting, readback and control is via the Master. The slave unit displays **Slave** on the home screen. Access via Menu selection B-6-2.

#### 3.4.4 POWER ON MODE<sup>(‡)</sup>

Establishes whether the power supply output is ON when starting up or recovering from an interruption of the input mains supply. Access via Menu selection B-7.

**OFF:** The power supply output will always be off upon restart Access via Menu selection B-7-1.

**LAST:** The power supply output will be restored to the condition it was in when power was turned off or the input mains supply was interrupted. Access via Menu selection B-7-2.

#### 3.4.5 OUTPUT PRIORITY<sup>(‡)</sup>

Establishes the operating mode when the output is set to ON or OFF: CV, CC, CP. Access via Menu selection B-8.

**CV:** The power supply output will be set to CV (Constant Voltage) mode when the output is set to ON or OFF. Access via Menu selection B-8-1.

**CC:** The power supply output will be set to CC (Constant Current) mode when the output is set to ON or OFF. Access via Menu selection B-8-2.

**CP:** The power supply output will be set to CP (Constant Power) mode when the output is set to ON or OFF. Access via Menu selection B-8-3.

#### 3.4.6 OUTPUT VARY ADJUST<sup>(‡)</sup>

Establishes whether changes in voltage with the output ON will appear at the output immediately or require tapping the ENTER switch on the front panel first. Access via Menu selection B-9.

**Enter:** Changes in output voltage with output ON require ENTER to be tapped before the changes appear at the output. Access via Menu selection B-9-1.

**Direct:** Changes in output voltage with output ON appear at the output immediately, as the encoder is rotated. Access via Menu selection B-9-2.

### 3.4.7 OUTPUT VARY RECALL (‡)

Establishes whether changes in operating settings (voltage, current, power, time) made by recalling one of the three stored settings (A, B, or C) with the output ON will appear at the output immediately or require tapping the ENTER switch on the front panel first. Access via Menu selection B-10.

**Enter:** Changes made by recalling stored settings with output ON require ENTER to be tapped before the changes appear at the output. Access via Menu selection B-10-1.

**Direct:** Changes made by recalling stored settings with output ON appear at the output immediately, as soon as the setting is recalled. Access via Menu selection B-10-2.

### 3.4.8 INTERNAL RESISTANCE (†)(‡)

Allows the value of simulated internal resistance to be adjusted within a range established by Model (see Table 3-4)<sup>(\*)</sup>. Access via Menu selection B-11.

### 3.4.9 OUTPUT ON RAMP TIME (‡)

Allows the value of output ON ramp time to be adjusted. This determines how long it takes for output voltage to ramp up from 5% to 95% of the setting value once the output is turned ON. This setting affects the slope (ramp up) of voltage, current or power, as determined by the setting of Output ON Priority (see PAR. 3.4.5). Access via Menu selection B-12.

**CAUTION: Output On Ramp Time can be set from 00.00 to 99.99 seconds, however it should not be set to less than the Response Time, Full Load (up) listed under Output Characteristics in Table 1-3.**

NOTE: This setting is not active when running in Sequence or Insertion Modes.

### 3.4.10 OUTPUT OFF RAMP TIME (‡)

Allows the value of output OFF ramp time to be adjusted. This determines how long it takes for output voltage to go from 95% to 5% of set value once the output is turned OFF. This setting affects the slope (ramp down) of voltage, current or power, as determined by the setting of Output ON Priority (see PAR. 3.4.5). Access via Menu selection B-13.

**CAUTION: Output Off Ramp Time can be set from 00.00 to 99.99 seconds, however it should not be set to less than the Response Time, Full Load (down) listed under Output Characteristics in Table 1-3.**

NOTE: This setting is not active when running in Sequence, Insertion Modes.

### 3.4.11 VOLTAGE SLEW RATE<sup>(†)</sup>

Adjusts the voltage slew rate in V/ms, the rate at which changes made to voltage appear at the output. Access via Menu selection B-14.

**TABLE 3-4. SIMULATED INTERNAL RESISTANCE RANGE**

Model	Internal Resistance
5KW Models	
KLN 80-180E	0 to 0.4444 Ohms
KLN 250-60E	0 to 4.1666 Ohms
KLN 350-42E	0 to 8.3333 Ohms
KLN 500-30E	0 to 16.666 Ohms
KLN 650-23E	0 to 28.260 Ohms
10KW Models	
KLN 80-360E	0 to 0.2221 Ohms
KLN 250-120E	0 to 2.0833 Ohms
KLN 350-84E	0 to 4.1666 Ohms
KLN 500-60E	0 to 8.3333 Ohms
KLN 650-46E	0 to 14.130 Ohms
KLN 1000-30E	0 to 33.333 Ohms
15KW Models	
KLN 80-540E	0 to 0.1481 Ohms
KLN 250-180E	0 to 1.3888 Ohms
KLN 350-126E	0 to 2.7777 Ohms
KLN 500-90E	0 to 5.5555 Ohms
KLN 650-69E	0 to 9.4202 Ohms
KLN 1050-42E	0 to 25.000 Ohms
KLN 1500-30E	0 to 50.000 Ohms

### 3.4.12 CURRENT SLEW RATE<sup>(‡)</sup>

Adjusts the current slew rate in A/ms, the rate at which changes made to current appear at the output. Access via Menu selection B-15.

### 3.4.13 POWER SLEW RATE<sup>(†)(‡)</sup>

Adjusts the power slew rate in W/ms, the rate at which changes made to power appear at the output. Access via Menu selection B-16.

### 3.4.14 I/O (EXTERNAL ON/OFF AND INTERLOCK)<sup>(‡)</sup>

Controls the External ON/OFF and Interlock functions of the power supply. Access via Menu selection B-17.

**External On/Off:** Set to Enable to allow control of output ON/OFF from pin 2 of the I/O Auxiliary port (see Table 2-2 and PAR. 3.7.1). When set to Disable, pin 2 of the I/O port has no effect on the output. Access via Menu selection B-17-1. When External On/Off is enabled, control of output ON/OFF from the front panel and digital interface is disabled.

**Interlock:** Set to Enable to control the Interlock feature from pin 1 of the I/O Auxiliary port (see Table 2-2) When set to Disable, pin 1 of the I/O port has no effect on the output. Access via Menu selection B-17-2.

### 3.4.15 SYSTEM FUNCTIONS<sup>(‡)</sup>

System functions include control of the alarm buzzer, key beep, LCD brightness, network time correction and calendar and time zone. These functions are accessed via Menu selection C.

#### 3.4.15.1 ALARM BUZZER ENABLE/DISABLE<sup>(‡)</sup>

Controls the audible alarm. When set to Enable, the alarm buzzer sounds when an alarm occurs. When set to Disable, the alarm buzzer does not sound. Access via Menu selection C-1.

#### 3.4.15.2 KEY BEEP ENABLE/DISABLE<sup>(‡)</sup>

Controls whether an audible beep sounds when front panel control or switch is change, or a virtual key is pressed. When set to Enable, a beep sounds when a key or switch is pressed or a control is rotated. When set to Disable, these actions are silent. Access via Menu selection C-2.

#### 3.4.15.3 LCD BRIGHTNESS<sup>(‡)</sup>

Controls the background brightness of the LCD touchscreen. Brightness range is 1 (dimpest) through 9 (brightest). Access via Menu selection C-3.

#### 3.4.15.4 DISPLAY COLOR<sup>(‡)</sup>

Controls the colors of the Home screen for Complete Mode (Figure 3-2, left side), except the Store/Recall key is not affected. Access via Menu selection C-4.

**White:** Causes the background of the Home screen to be black, background color of the keys to be white, and text to be black. Access via Menu selection C-4-1.

**Black:** Causes the background of the Home screen to be white, background color of the keys to be black, and text to be white. Access via Menu selection C-4-2.

**Green:** Causes the background of the Home screen to be black, background color of the keys to be green, and text to be green. Access via Menu selection C-4-3.

#### 3.4.15.5 TOUCH SCREEN ENABLE/DISABLE<sup>(‡)</sup>

Controls whether the touch screen is active (Enable) or not (Disable). The displays are still visible, but the touchscreen does not respond to touches if it is disabled. NOTE: If the touch screen is disabled, front panel control of the unit is by using the Menu (see PAR. 3.3). Access via Menu selection C-5.

#### 3.4.15.6 NETWORK TIME SYNCHRONIZATION<sup>(‡)</sup>

Controls automatic updating of the date/time that is displayed on the Home screen. If set to Enable, the power supply must be connected to the Internet, and Port 123 for the NTP server must not be blocked by a firewall for the update to work properly. Access via Menu selection C-6.



### 3.4.15.7 CALENDAR SETTING<sup>(‡)</sup>

Allows the date/time to be set manually. Access via Menu selection C-7.

### 3.4.15.8 TIME ZONE SETTING<sup>(‡)</sup>

Allows the displayed time to match the local time zone. For example, for EST (Eastern Standard Time) the setting would be UTC+8:00. Access via Menu selection C-8.

### 3.4.15.9 CALIBRATION

See Section 4 for Calibration procedures. Access via Menu selection C-9.

### 3.4.16 LAN INTERFACE SETTINGS<sup>(‡)</sup>

LAN Interface Settings include display of IP Information, auto or manual IP address, SCPI-RAW Port number, Message Terminator, NTP Server Settings and Reset LAN functions. These functions are accessed via Menu selection D.

#### 3.4.16.1 IP INFORMATION<sup>(‡)</sup>

Allows the user to view the current MAC, IP, Subnet Mask, Gateway and DNS addresses. The IP address is used for remote operation of the unit via the LAN interface (see PAR. 3.4. Access via Menu selection D-1.

#### 3.4.16.2 AUTO IP<sup>(‡)</sup>

Allows the IP address to be obtained from the DNCP server automatically when set to Enable. It must be set to Disable in order to set the IP address manually. Access via Menu selection D-2.

#### 3.4.16.3 MANUAL IP<sup>(‡)</sup>

This function must first be enabled by setting Auto IP to Disable (see PAR. 3.4.16.2). Allows the IP, Subnet, Gateway and DNS addresses to be configured. Access via Menu selection D-3.

**IP Address 1:** Set the first three digits of IP address. Access via Menu selection D-3-1.

**IP Address 2:** Set the next three digits of IP address. Access via Menu selection D-3-2.

**IP Address 3:** Set the next three digits of IP address. Access via Menu selection D-3-3.

**IP Address 4:** Set the next three digits of IP address. Access via Menu selection D-3-4.

**Subnet Mask Address 1:** Set the first three digits of Subnet Mask address. Access via Menu selection D-3-5.

**Subnet Mask Address 2:** Set the next three digits of Subnet Mask address. Access via Menu selection D-3-6.

**Subnet Mask Address 3:** Set the next three digits of Subnet Mask address. Access via Menu selection D-3-7.

**Subnet Mask Address 4:** Set the next three digits of Subnet Mask address. Access via Menu selection D-3-8.

**Gateway Address 1:** Set the first three digits of Gateway address. Access via Menu selection D-3-9.

**Gateway Address 2:** Set the next three digits of Gateway address. Access via Menu selection D-3-10.

**Gateway Address 3:** Set the next three digits of Gateway address. Access via Menu selection D-3-11.

**Gateway Address 4:** Set the next three digits of Gateway address. Access via Menu selection D-3-12.

**DNS Address 1:** Set the first three digits of DNS address. Access via Menu selection D-3-13.

**DNS Address 2:** Set the next three digits of DNS address. Access via Menu selection D-3-14.

**DNS Address 3:** Set the next three digits of DNS address. Access via Menu selection D-3-15.

**DNS Address 4:** Set the next three digits of DNS address. Access via Menu selection D-3-16.

**Setting Done:** When all IP, Subnet Mask, Gateway and DNS addresses are correct this function is used to save the settings. Access via Menu selection D-3-17.

#### 3.4.16.4 SCPI-RAW PORT<sup>(‡)</sup>

Sets the port number for the SCPI-RAW Port. The default is 5025. Access via Menu selection D-4.

#### 3.4.16.5 MESSAGE TERMINATOR<sup>(‡)</sup>

Sets the protocol to recognize end-of-line. Access via Menu selection D-5.

**Cr:** Carriage Return. Access via Menu selection D-5-1.

**Lf:** Line Feed. Access via Menu selection D-5-2.

**Cr + Lf:** Carriage Return plus Line Feed (default). Access via Menu selection D-5-3.

#### 3.4.16.6 NTP SERVER<sup>(‡)</sup>

Sets the NTP Server address. Access via Menu selection D-6.

**NTP Address 1:** Set the first three digits of NTP address. Access via Menu selection D-6-1.

**NTP Address 2:** Set the next three digits of NTP address. Access via Menu selection D-6-2.

**NTP Address 3:** Set the next three digits of NTP address. Access via Menu selection D-6-3.

**NTP Address 4:** Set the next three digits of NTP address. Access via Menu selection D-6-4.

**Setting Done:** When NTP addresses are correct, this function is used to save the settings. Access via Menu selection D-6-5.

### 3.4.16.7 RESET LAN<sup>(‡)</sup>

Resets the following LAN settings to the default value:

- Auto IP: (Menu selection D-2): Enable
- SCPI RAW Port (Menu selection D-4): 5025
- NTP Server (Menu selection D-6): 118.163.81.62

Access via Menu selection D-7.

### 3.4.17 OPTIONAL INTERFACE SETTINGS<sup>(‡)</sup>

LAN Interface Settings include display of IP Information, auto or manual IP address, SCPI-RAW Port number, Message Terminator, NTP Server Settings and Reset LAN functions. These functions are accessed via Menu selection D.

#### 3.4.17.1 ANALOG INTERFACE<sup>(‡)</sup>

Only available if optional Isolated Analog Interface is installed. Access via Menu selection E-1.

##### 3.4.17.1.1 ANALOG VOLTAGE LEVEL<sup>(‡)</sup>

Sets the voltage range used for analog programming of Voltage, Current and Power (see Table 3-7) at either **0~5V** or **0~10V**. Also determines voltage range used for analog output monitor signals for voltage, current and power. Access via Menu selection E-1-1.

##### 3.4.17.1.2 ANALOG VOLTAGE PROGRAMMING ENABLE/DISABLE<sup>(‡)</sup>

Enables or disables programming of voltage through the analog programming port (see Table 3-7). Access via Menu selection E-1-2.

##### 3.4.17.1.3 ANALOG CURRENT PROGRAMMING ENABLE/DISABLE<sup>(‡)</sup>

Enables or disables programming of current through the analog programming port (see Table 3-7). Access via Menu selection E-1-3.

##### 3.4.17.1.4 ANALOG POWER PROGRAMMING ENABLE/DISABLE<sup>(‡)</sup>

Enables or disables programming of power through the analog programming port (see Table 3-7). Access via Menu selection E-1-4.

##### 3.4.17.1.5 ANALOG MONITOR OUTPUT ENABLE/DISABLE<sup>(‡)</sup>

Enables or disables analog monitoring signals for voltage, current and power (see Table 3-7). Access via Menu selection E-1-5.

#### 3.4.17.2 RS 422/RS 485 & USB INTERFACE<sup>(‡)</sup>

Only available if optional IEEE 488 (GPIB) Interface is installed. Access via Menu selection E-2.

#### 3.4.17.2.1 RS 422/RS 485 MODE SELECT<sup>(‡)</sup>

Used to set or view the GPIB address. Address range is from 00 to 30. Access via Menu selection E-2-1-1.

**RS-485 Mode:** Sets the pluggable PCB terminals to perform as RS-485 (see PAR. 3.10.3.1).

**RS-422 Mode:** Set the pluggable PCB terminals to perform as RS-422 (see PAR. 3.10.3.2).

#### 3.4.17.2.2 RS 422/RS 485 ADDRESS MODE ENABLE/DISABLE<sup>(‡)</sup>

This setting allows the user to determine whether or not the address is required when sending the commands. For example, "A007SYST:REM". Access via Menu selection E-2-1-2.

**Enable:** The address is required at the beginning of commands.

**Disable:** The address is not required.

#### 3.4.17.2.3 RS 422/RS 485 TERMINAL RESISTOR ENABLE/DISABLE<sup>(‡)</sup>

To enable or disable the requirement for a terminal resistor in the daisy chain. Access via Menu selection E-2-1-3.

#### 3.4.17.2.4 RS 422/RS 485 ADDRESS<sup>(‡)</sup>

Set or view the address, range A001 ~ A254. Access via Menu selection E-2-1-4.

#### 3.4.17.2.5 RS 422/RS 485 BAUD RATE<sup>(‡)</sup>

Set or view the baud rate, range 4800 / 9600 / 19200 / 38400 / 57600 / 115200. Access via Menu selection E-2-1-5.

#### 3.4.17.2.6 RS 422/RS 485 DATA BIT<sup>(‡)</sup>

Shows the serial port parameter setting 8,n,1 (cannot be changed). Access via Menu selection E-2-1-6.

#### 3.4.17.2.7 RS 422/RS 485 FLOW CONTROL<sup>(‡)</sup>

Shows the flow control, it is fixed to None. Access via Menu selection E-2-1-7.

#### 3.4.17.2.8 RS 422/RS 485 MESSAGE TERMINATOR<sup>(‡)</sup>

Set or view message terminator, **Cr** / **Lf** / **Cr+Lf**. Access via Menu selection E-2-1-8.

#### 3.4.17.3 IEEE 488 (GPIB) INTERFACE<sup>(‡)</sup>

Only available if optional IEEE 488 (GPIB) Interface is installed. Access via Menu selection E-3.

##### 3.4.17.3.1 GPIB ADDRESS VIEW/SET<sup>(‡)</sup>

Set or view the GPIB address. Address range from 00 to 30. Access via Menu selection E-3-1.

### 3.4.18 INFORMATION MENU(†)

Provides access to System Information (e.g., Model, Manufacturer, Serial no. Firmware Version no. and Hardware Version no.), Contact Us, and System Log. Access via Menu selection F.

#### 3.4.18.1 SYSTEM INFORMATION(†)

Provides access to System Information: Model, Manufacturer, Serial no. Firmware Version no. and Hardware Version no. Access via Menu selection F-1.

#### 3.4.18.2 CONTACT US(†)

Provides access to Kepco's contact information. Access via Menu selection F-2.

#### 3.4.18.3 SYSTEM LOG(†)

Provides access to a log of actions, e.g., Output ON, Output OFF. Access via Menu selection F-3.

### 3.4.19 LOAD DEFAULT(†)

Allows the user to restore the factory default variables listed in Table 3-3. Access via Menu selection G.

**ESC:** Escape (cancel) and return to the previous screen without loading the defaults. Access via Menu selection G-1.

**LOAD:** Loads the factory defaults listed in Table 3-3, then returns to the previous screen. Access via Menu selection G-2.

### 3.5 FIRMWARE UPGRADE(†)

When upgrades are available, the firmware is upgraded using a flash memory drive inserted in the front panel USB port. Separate instructions are supplied with the firmware upgrade kit.

### 3.6 SERIES/PARALLEL OPERATION

The following paragraphs describe operation of multiple units connected in series or parallel

#### 3.6.1 SERIES OPERATION

Units connected in series do not support master/slave control. Operate the units as if each unit is independent.

**CAUTION: TO ENSURE THE PROTECTION FUNCTIONS WORK PROPERLY, SET OVP VALUE HIGHER THAN THE COMBINED OUTPUT OF BOTH UNITS.**

1. Once the units have been connected in series (see PAR. 2.8.1), power up both units.
2. On both units, set output to off (disabled)

**CAUTION: A MAXIMUM OF TWO UNITS CAN BE CONNECTED IN SERIES. TOTAL VOLTAGE MUST NOT EXCEED 1500V TO AVOID DAMAGING THE UNITS. TOTAL VOLTAGE MUST NOT EXCEED THE ISOLATION VOLTAGE AN INDIVIDUAL UNIT.**

3. Adjust voltage of each unit to half of the desired output of the series-connected pair.
4. Set OVP of both units to be higher than the desired output of the series-connected pair.
5. Set output to on (enabled) on both units.

### 3.6.2 DISCONTINUING SERIES OPERATION

1. On both units, set output to off (disabled)
2. Set power switch of both units to off.
3. Set mains power to off, and disconnect both units from a-c mains.
4. Remove all series connections.

### 3.6.3 PARALLEL OPERATION

Control units connected in parallel using the master, either via the LAN or from the front panel, to operate the parallel-connected group.

**WARNING: THE INPUT CABLES AND OUTPUT COPPER BARS OF PARALLEL-CONNECTED UNITS THAT ARE SWITCHED OFF ARE STILL ELECTRIFIED.**

When the required power is less than the total amount of paralleled capacity, it is possible to conserve energy by turning off some (power switch in  position) of the Slave units to reduce energy consumption without disconnecting the units.

If the required power can be satisfied by the Master unit alone, all the Slave units may be powered off, but the Master unit should be set to Independent (see PAR. 3.4.3, access via Menu B-6). The priority for powering off the Slave units is: first power off the Slave furthest from the Master, then the next furthest Slave, etc.

Powering off a Slave while the output is set to ON causes the Master to set the output to OFF and an error code will be generated.

### 3.6.4 DISCONTINUING PARALLEL OPERATION

To allow units connected in parallel to function independently, proceed as follows:

1. Set Master Output to OFF
2. Power off all slaves (power switch to  position). First power off the Slave furthest from the Master, then next furthest Slave, etc.
3. Power off Master (power switch to  position).
4. With mains power off, disconnect all units from a-c mains.
5. Disconnect all parallel connections.
6. Connect units (as needed) to a-c mains, then power up unit and set Master/Slave mode to Independent. (see PAR. 3.4.3, access via Menu B-6).

### 3.7 USING THE I/O AUXILIARY PORT

#### 3.7.1 EXTERNAL OUTPUT ON/OFF

The output of the unit can be set on or off remotely using pin 2 of the I/O Auxiliary port (Table 2-2) when first enabled from the menu (see PAR. 3.4.14). This can be accomplished using either an optocoupler or relay as shown in Figure 3-18. When pin 2 is shorted to pin 6, 7, 8 or 9, the output is on (enabled). The output is off (disabled) when there is an open circuit between pin 2 and pins 6, 7, 8 and 9.

#### 3.7.2 EXTERNAL OUTPUT SHUTOFF

Pin 3 can be used to set the output to off. When pin 2 is shorted to pin 6, 7, 8 or 9, the output is set to off (disabled); Setting the output to off using pin 3 also produces an error code 82 (External Shut Off)

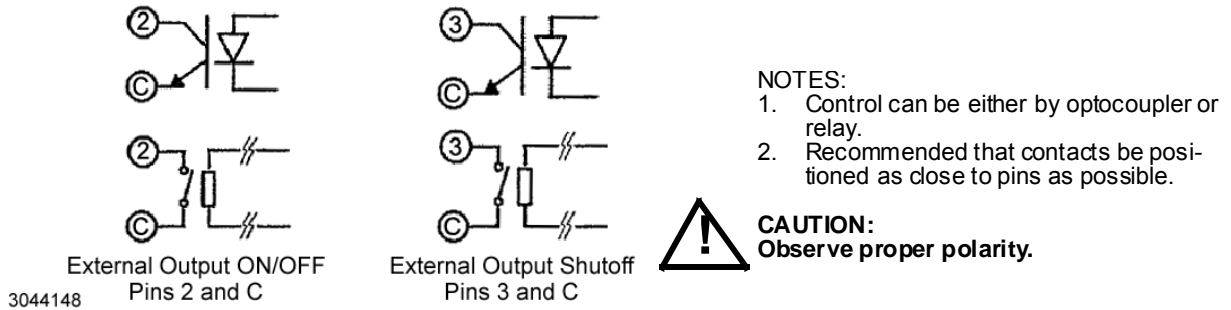

**FIGURE 3-17. OUTPUT ON/OFF AND OUTPUT SHUTOFF CONTROL USING I/O AUXILIARY PORT AND OPTOCOUPLER OR RELAY**

#### 3.7.3 MONITORING STATUS USING I/O AUXILIARY PORT

Two output signals are available from the I/O Auxiliary port (Table 2-2) to monitor status. Pin 4 monitors alarm status. Pin 5 provides an indication when output voltage is being adjusted downward more than 1% of present value. This can be useful if the user elects to add an external discharge circuit to the output in order to speed up fall time of the output voltage. These two signals are Open collector, short when

The status signals are open collector TTL signals via an optocoupler referenced to common (pin 6, 7, 8, or 9): maximum voltage is 30V, maximum current is 8mA. Open (TTL high) from pin 4 (alarm) or pin 5 (Voltage adjust downward) to common (pin 6, 7, 8 or 9) indicates condition not present. When open (TTL high) changes to short (TTL low) the condition (either alarm or voltage adjust downward) is present.

#### 3.7.4 INTERLOCK CONTROL

Pin 1 of the I/O Auxiliary port (Table 2-2) functions as an interlock when enabled from the Menu (see PAR. 3.7.4). If the interlock is enabled, the unit will only operate as long as a short is maintained between pin 1 and pin 6, 7, 8 or 9. If the short changes to an open circuit, the unit does not operate and an error code 81 (Interlock Error) is generated. To resume normal operation restore the short between pin 1 and pin 6, 7, 8 or 9.

### 3.8 DIGITAL REMOTE MODE PROGRAMMING

KLN models may be digitally programmed over a control bus using SCPI (Standard Commands for Programmable Instruments). SCPI provides a common language conforming to IEEE 488.2 for instruments used in an automatic test system (see PAR. 3.9). The control bus used must be the LAN interface. Refer to PAR. 3.9 for a detailed discussion of SCPI programming.

This section includes the requirements for

- LAN Operation (see PAR. 3.8.1)

#### 3.8.1 LAN OPERATION

1. Connect the KLN to the computer (see PAR. 2.9.2 for LAN connections).
2. Refer to PAR. 3.4.16.1 to find the IP address of the unit.
3. Enter the IP address of the unit in a browser to access via the LAN interface. Once the connection is made, the browser displays the Instrument Welcome Page (see PAR. 3.8.1.1)

##### 3.8.1.1 INSTRUMENT WELCOME (HOME) PAGE

The Instrument Welcome Page displays information about the power supply as shown in Figure 3-18. Clicking on the **Toggle** button to the right of Device Indicator **Inactive** causes the LAN indicator on the unit's front panel to blink; the screen changes to show Device Indicator **Active**. Clicking the **Toggle** button again restores Device Indicator **Inactive** and the LAN indicator reverts back to steady on. To return to the Instrument Welcome page from a different screen, click Home Page at the menu on the left.

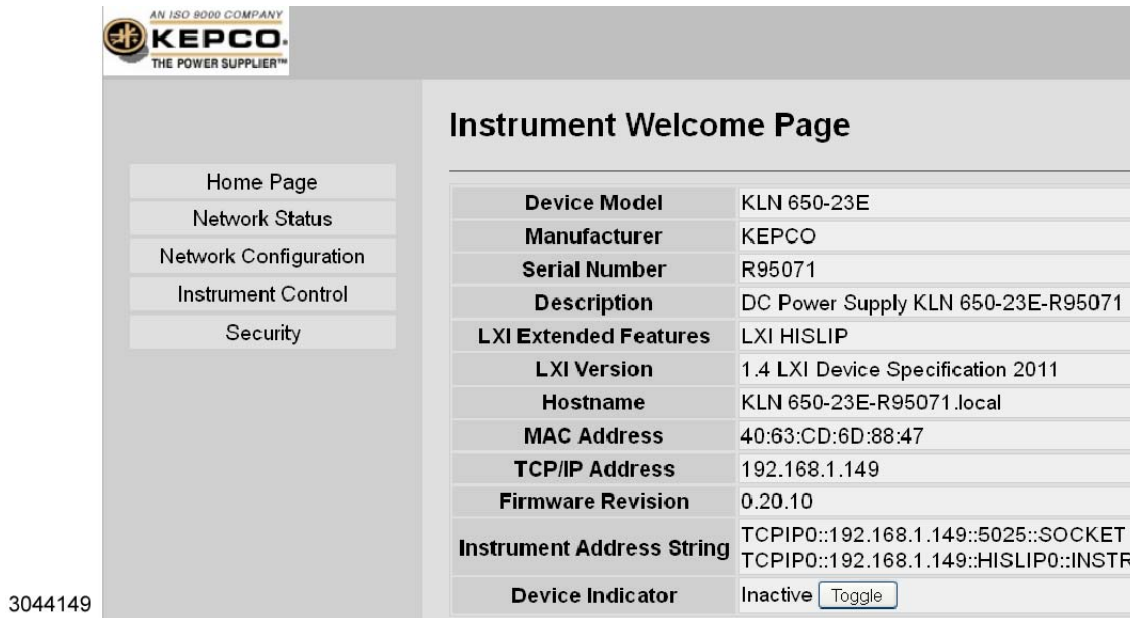

FIGURE 3-18. INSTRUMENT WELCOME (HOME) PAGE



### 3.8.1.2 NETWORK STATUS

From the Instrument Welcome page, clicking **Network Status** at the top left shows the Network Status Page (see Figure 3-19). Data displayed can not be changed from this page.

3044150

TCP/IP Configuration	
IP Configured By	Manual
IP address	192.168.1.149
IP Subnet Mask	255.255.255.0
Default Gateway	192.168.1.10
DNS Server	0.0.0.0

Network Identification	
Host Name	KLN 650-23E-R95071
Service Name	DC Power Supply KLN 650-23E-R95071
mDNS Domain Name	local
mDNS Discovery	Enable

Network Hardware Configuration	
MAC Address	40:63:CD:6D:88:47
Link Speed and Duplex Mode	100Mbps and Full Duplex

FIGURE 3-19. NETWORK STATUS PAGE

### 3.8.1.3 VIEWING AND/OR CHANGING IP CONFIGURATION

Clicking **Network Configuration** brings up the Login screen (see Figure 3-20). Enter the password (admin is the default password) and click **Submit** to continue and view the Network Configuration Page (see Figure 3-21).

3044151

Login	
Enter the Password	
Password	<input type="password"/>
	<input type="submit" value="Submit"/>

FIGURE 3-20. LOGIN SCREEN

The screenshot shows a web interface for network configuration. On the left is a navigation menu with options: Home Page, Network Status, Network Configuration (selected), Instrument Control, and Security. The main content area is titled 'Network Configuration' and is divided into two sections:

**Network Identification**

Host Name	KLN 650-23E-R95071
Description	DC Power Supply KLN 650-23E-R95071
mDNS Discovery	<input checked="" type="radio"/> Enable <input type="radio"/> Disable
<input type="button" value="Apply"/> <input type="button" value="Undo Change"/>	

**TCP/IP Configuration**

IP Address Configuration	<input type="radio"/> Automatic <input checked="" type="radio"/> Manual
IP Address	192 . 168 . 1 . 149
Subnet Mask	255 . 255 . 255 . 0
Default Gateway	192 . 168 . 1 . 10
DNS Server Address	0 . 0 . 0 . 0
Socket Port	5025
<input type="button" value="Apply"/> <input type="button" value="Undo Change"/>	

At the bottom of the configuration area is a  button.

3044152

**FIGURE 3-21. NETWORK CONFIGURATION PAGE**

The three fields of the top section allow the user to set **Host Name** and **Description** as well as enable or disable **mDNS Discovery**. Using mDNS allows the KLN to determine the IP address of a given host (a host name) without the direct help of a centralised DNS server. Once changes have been made, immediately below the top section click on **Undo Change** to revert to the previous settings, or **Apply** to apply the changes.

The lower section determines where the IP Address and DNS Server address comes from, and can be used to manually change the Socket Port from 5025 (the default) if needed. Setting **IP Address Configuration** to **Automatic** allows the IP, Subnet Mask and Default Gateway addresses to be found automatically. If **IP Address Configuration** is set to **Manual**, the user can enter the desired addresses, Similarly, Setting **DNS Server Address** allows the DNS Server address to be assigned by the user. Once changes have been made, immediately below the lower section click on **Undo Change** to revert to the previous settings, or **Apply** to apply the changes. Clicking on **Reset LAN** will restore the IP Configuration Settings to the factory defaults.

### 3.8.1.4 CHANGING LAN PASSWORD

When operating the KLN via the LAN for the first time, click **Security** at the top left to bring up the Change Password screen (Figure 3-22). If desired, change the old password from the default (admin) to one of your choosing. Ensure that New Password and Confirm Password fields are identical and click **Apply**.

3044153

Home Page
Network Status
Network Configuration
Instrument Control
Security

### Security

---

#### Change Password

Old Password	<input type="text"/>
New Password	<input type="text"/>
Confirm Password	<input type="text"/>
	<input type="button" value="Apply"/> <input type="button" value="Clear"/>

FIGURE 3-22. CHANGE PASSWORD SCREEN

### 3.8.1.5 INSTRUMENT CONTROL

The Instrument Control page (see Figure 3-23) contains the basic controls used to operate the KLN power supply. To view the Instrument Control page, click on **Instrument Control** on the menu at the left of the page. You may be asked to Log In with a password before access to this screen is granted. Table 3-5 explains how to use the Instrument Control page to operate the power supply.

**TABLE 3-5. INSTRUMENT CONTROL PAGE**

Figure 3-23 Item No.	Explanation
1	This area displays measured values when the output is turned on. The Time setting shows timed remaining for the output to be on, then the output is turned off when time = 0.
2	This area displays the operating mode of the power supply, either CC (Constant Current), CV (Constant Voltage) or CP (Constant Power) when the output is on, OFF when the output is off.
3	Output waveform monitor displays real time waveforms of voltage, current and power (determined by check boxes, see item no. 4) while the output is turned on. The vertical axis represents the amplitude of (voltage/current/power) which has 11 grids representing 0~110% of rated (voltage/current/power). The horizontal axis represents the time, the time per division is selectable (see item no. 6).
4	These check boxes enables display of one or more of the Voltage, Current or Power waveforms (see item no. 3)
5	START / STOP button starts or stops displaying the waveform(s); displayed waveform will be cleared after re-start
6	Selectable time per division, 0.5S / 1S / 2S / 5S per division for Output waveform monitor
7	These fields allow the values of voltage, current, power and output on time to be altered and applied to the output when the output is turned on. Once changes have been completed, click <b>Apply</b> to apply the settings, or <b>Undo Change</b> to cancel the changes.
8	This field allows the user to set the <b>iNternal Resistance<sup>(†)</sup></b> of the power supply (see PAR. 3.4.8) When Internal Resistance, OVP and OCP changes are complete, click corresponding <b>Apply</b> button to apply the settings, or <b>Undo Change</b> to cancel the changes.
9	This field allows the user to alter the <b>OVP</b> (Overvoltage Protection) value. When Internal Resistance, OVP and OCP changes are complete, click corresponding <b>Apply</b> button to apply the settings, or <b>Undo Change</b> to cancel the changes.
10	This field allows the user to alter the <b>OCP</b> (Overcurrent Protection) value. When Internal Resistance, OVP and OCP changes are complete, click corresponding <b>Apply</b> button to apply the settings, or <b>Undo Change</b> to cancel the changes.
11	This field allows the user to alter the Voltage Slew Rate value. When Voltage Slew Rate, Current Slew Rate and Power Slew Rate changes are complete, click corresponding <b>Apply</b> button to apply the settings, or <b>Undo Change</b> to cancel the changes.
12	<b>Output OFF/ON</b> button used to either disable (OFF) or enable (ON) the output
13	<b>Instrument Reset</b> button sets the voltage and current to the default values, sets the output to off, and resets the alarm if it is on

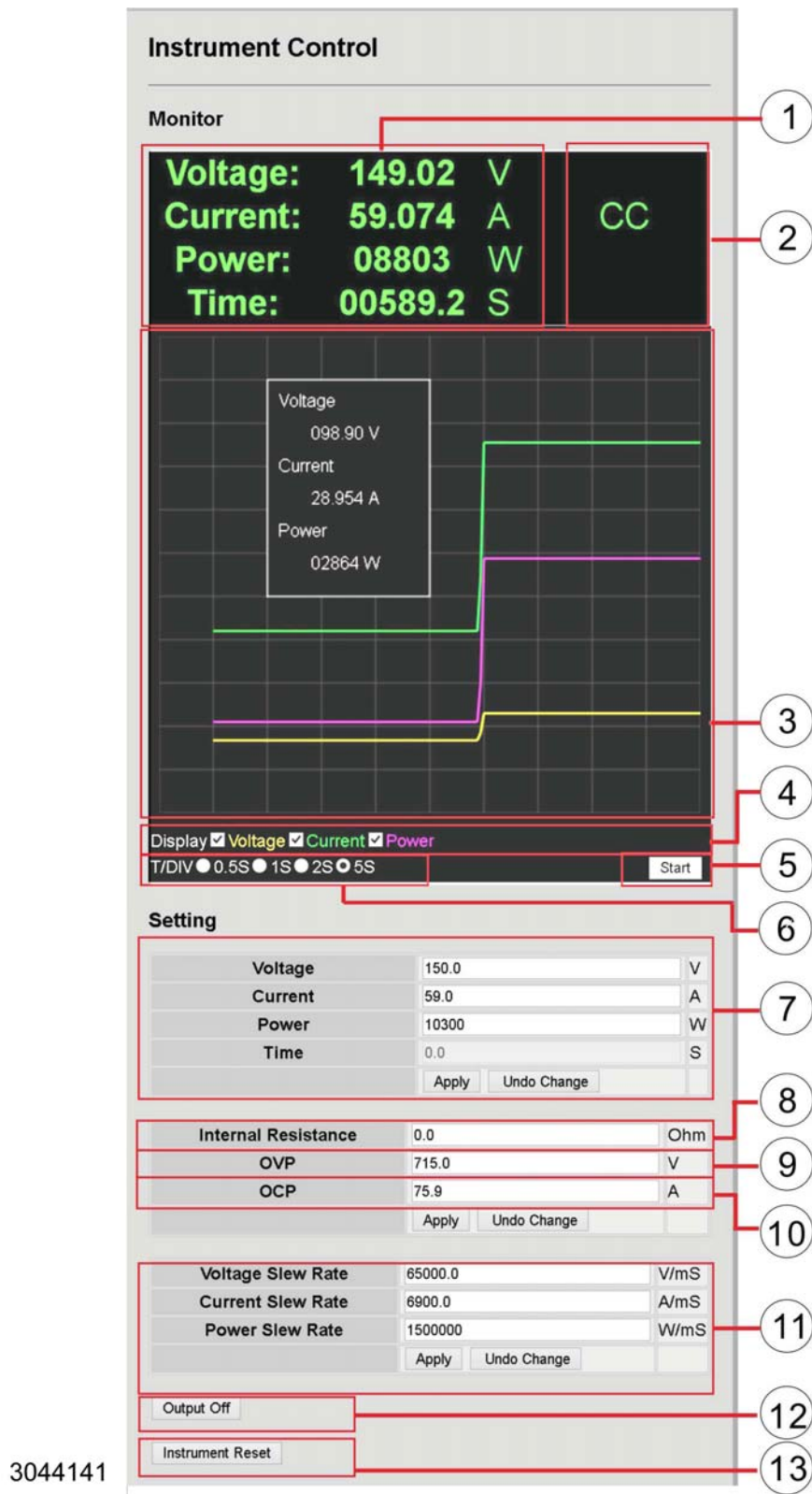

3044141

FIGURE 3-23. INSTRUMENT CONTROL PAGE

### 3.8.1.6 USING TERMINAL EMULATION SOFTWARE TO VERIFY CORRECT CONNECTION.

Microsoft HyperTerminal or PuTTY can be used to operate the unit remotely via the LAN connection to verify that the LAN connection is operating properly. Use Automatic IP Address Configuration and Socket Port 5025.

NOTE: Microsoft HyperTerminal is not supported by Windows 7 or later versions. PuTTY executables are distributed under the MIT license:  
(<http://www.chiark.greenend.org.uk/~sgtatham/putty/licence.html>)

1. At the KLN EXT, access Menu E-2-5 and select the baud rate.
2. At the KLN EXT, access Menu E-2-8 and set the message terminator to **Cr**.
3. From the computer, launch PuTTY and from the Configuration tab select Category - Connection - Serial. At the "Serial line to connect to" field enter the COM port number, then enter the Baud Rate (see Figure 3-24

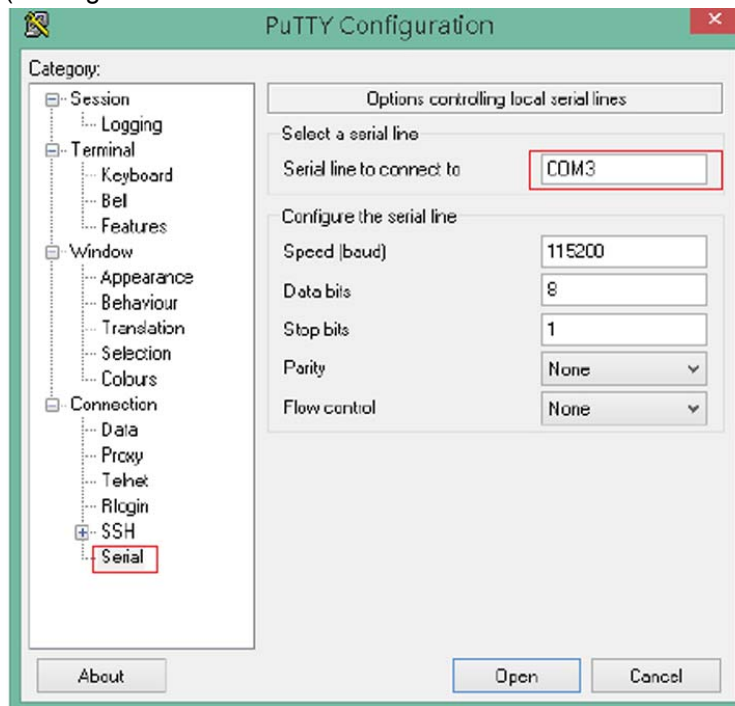
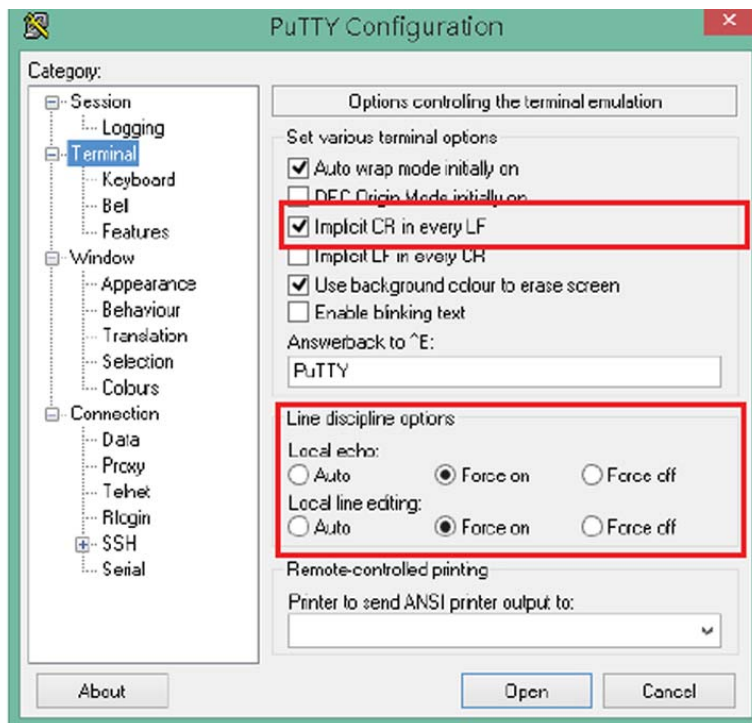

FIGURE 3-24. TERMINAL EMULATION CONFIGURATION

4. Select from the Configuration tab select Category - Terminal and check "**Implicit CR in every LF.**" Set "Local echo" to **Force on**, and set "Local line editing" to **Force on** (see Figure 3-25).



3044137

FIGURE 3-25. CONFIGURE TERMINAL

5. Under Category - Session, set "Connection Type" to **Serial** (see Figure 3-27)

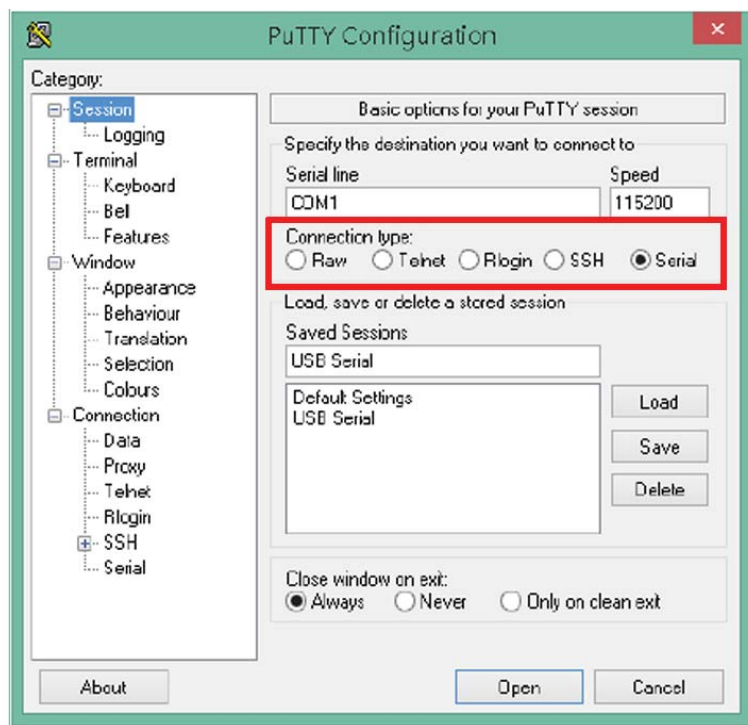

3044139

FIGURE 3-26. CONFIGURE SESSION

- Under Category - Terminal - Keyboard - set "The function keys and keypad" to **VT00+** (see Figure 3-26)

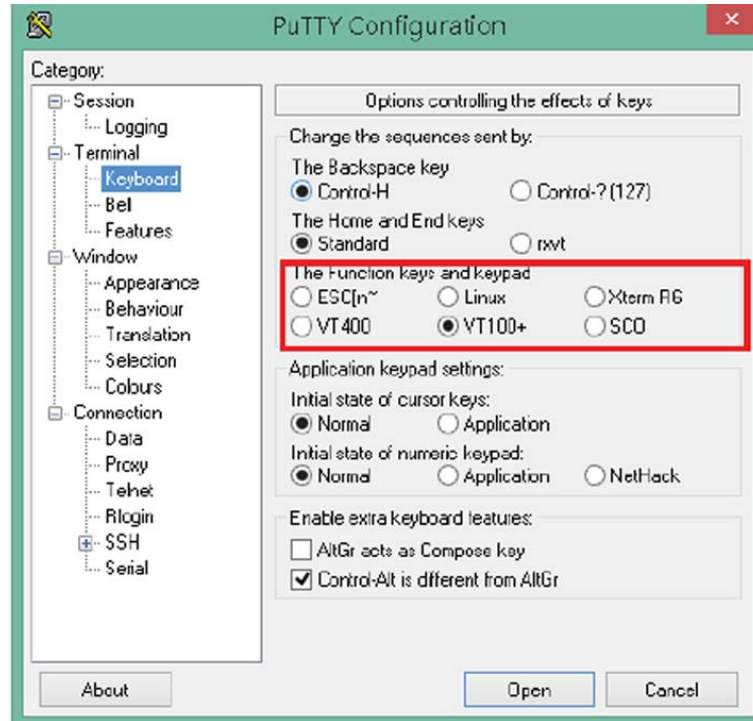

3044138

**FIGURE 3-27. CONFIGURE TERMINAL KEYBOARD**

- Send commands to the unit to verify it is operating properly via the LAN interface (see Figure 3-27)

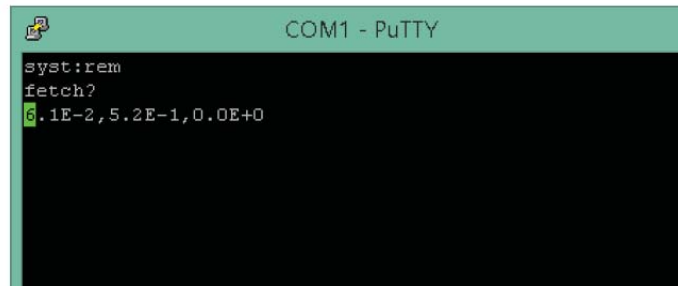

3044140

**FIGURE 3-28. SEND COMMANDS TO UNIT VIA TERMINAL EMULATOR**

### 3.9 SCPI PROGRAMMING

SCPI (Standard Commands for Programmable Instruments) is a programming language conforming to the protocols and standards established by IEEE 488.2 (reference document *ANSI/IEEE Std 488.2, IEEE Standard Codes, Formats, Protocols, and Common Commands*). The KLN Power Supply supports long and short form syntax as defined in this standard. All other aspects of this standard are specified in Appendix B of this manual. The unit ignores all incorrectly formatted messages, emitting an audible beep for each incorrect command sequence; the reason for the beep is placed in the error queue.



Different programming languages (e.g., BASIC, C, PASCAL, etc.) have different ways of representing data that is to be put on the IEEE 488 bus. It is up to the programmer to determine how to output the character sequence required for the programming language used. See Table 3-6 for VISA resource strings corresponding to RS-485, GPIB (G-suffix models only) or LAN (E-suffix models only) interfaces.

**TABLE 3-6. VISA RESOURCE STRING CORRESPONDING TO INTERFACE**

INTERFACE	VISA RESOURCE STRING	COMMENT
LAN	TCIP::192.168.0.100::5025::SOCKET	5025 is the default socket. See PAR 3.8.1.3 to verify or change the socket port. Address information not included with command sequences.

### 3.9.1 SCPI MESSAGES

There are two kinds of SCPI messages: program messages from controller to power supply, and response messages from the power supply to the controller. Program messages consist of one or more properly formatted commands/queries and instruct the power supply to perform an action; the controller may send a program message at any time. Response messages consist of formatted data; the data can contain information regarding operating parameters, power supply state, status, or error conditions.

### 3.9.2 COMMON COMMANDS/QUERIES

Common commands and queries are defined by the IEEE 488.2 standard to perform overall power supply functions (such as identification, status, or synchronization) unrelated to specific power supply operation (such as setting voltage/current). Common commands and queries are preceded by an asterisk (\*) and are defined and explained in Appendix A.

### 3.9.3 SCPI SUBSYSTEM COMMAND/QUERY STRUCTURE

Subsystem commands/queries are related to specific power supply functions (such as setting output voltage, current, etc.) Figure 3-35 is a tree diagram illustrating the structure of SCPI subsystem commands used in the KLN Power Supply with the root at the left side, and specific commands forming the branches. The following paragraphs introduce the subsystems; subsystem commands are defined and explained in Appendix B.

#### 3.9.3.1 ABORT SUBSYSTEM

This subsystem is used terminate outputting of transients.

#### 3.9.3.2 CALIBRATE SUBSYSTEM

This subsystem is used to calibrate the unit, however these commands and queries are not accessible to the user.

#### 3.9.3.3 DISPLAY SUBSYSTEM

This subsystem is used to set and ascertain the brightness on the front panel Voltage and Current displays.

#### 3.9.3.4 FETCH SUBSYSTEM

This subsystem is used to measure and return both voltage and current measurements.

### **3.9.3.5 INITIATE SUBSYSTEM**

This subsystem is used to initiate the transients specified by the Trigger subsystem.

### **3.9.3.6 LXI SUBSYSTEM**

This subsystem allows the front panel LAN indicator to blink, identifying the unit being accessed remotely.

### **3.9.3.7 MEASURE SUBSYSTEM**

This subsystem is used for measuring output voltage, current and power.

### **3.9.3.8 MEMORY SUBSYSTEM**

This subsystem is used to save and recall three separate settings of voltage, current, power and time (output on time).

### **3.9.3.9 OUTPUT SUBSYSTEM**

This subsystem is used to control whether the output is on or off, and whether the power supply powers up with the output set to the reset state or to the last settings in effect when the unit was powered off.

### **3.9.3.10 SOURCE SUBSYSTEM**

This subsystem is used to program the output voltage and current of the power supply, associated protection levels and limits and output ramp up and down times. This subsystem is also used to control the memory locations used to store power supply settings for later recall.

### **3.9.3.11 SYSTEM SUBSYSTEM**

This subsystem is used to control the audible beep upon key presses, enabling/disabling the front panel keys and reading of error codes and SCPI version.

### **3.9.3.12 TRIGGER SUBSYSTEM**

This subsystem allows the power supply to produce controlled transients at the output.

## **3.9.4 UNDERSTANDING THE COMMAND STRUCTURE**

Understanding the command structure requires an understanding of the subsystem command tree illustrated in Figure 3-35. The “root” is located at the top left corner of the diagram. The parser goes to the root if:

- a message terminator is recognized by the parser
- a root specifier is recognized by the parser

Starting at the root, there are various branches or paths corresponding to the subsystems. The root keywords for the KLN Power Supply are :CALibrate, :DISPlay, :FETCh, :INITiate, :LXI, :MEASure, :MEMory, :OUTPut, :SOURce, :STATus, :SYSTem and :TRIGger.

### 3.10 OPTIONAL INTERFACES

Remote programming of standard models (suffix E) is via the LAN interface using IEEE488.2 and SCPI commands and queries. In addition to the LAN interface, one of the following optional interfaces currently under development may also be installed:

- Isolated Analog (suffix A) - see PAR. 3.10.1
- IEEE 488.2 (GPIB) (suffix G) - see PAR. 3.10.2
- Serial/USB (RS422/RS485 & USB) (suffix S) - see PAR. 3.10.3

#### 3.10.1 ISOLATED ANALOG OPTIONAL INTERFACE

When the Isolated Analog interface is installed, control of the unit is via the 25-pin Analog Control connector (see Figure 3-29). Pin functions are defined in Table

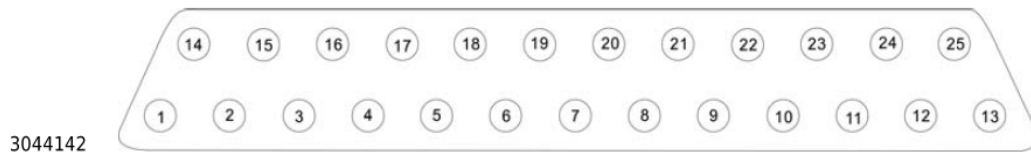

**FIGURE 3-29. ANALOG CONTROL CONNECTOR, PIN ASSIGNMENTS.**

**TABLE 3-7. ANALOG CONTROL CONNECTOR PIN FUNCTIONS**

PIN No. (FIGURE 3-29)	SIGNAL NAME	FUNCTION
1	CV State <sup>(1)</sup>	CV (Constant Voltage) operation selected by shorting Pin 1 to Pin 14 (open collector controlled by a photocoupler (see Figure 3-30). Must be enabled by referring to PAR. 3.4.17.1.2.
2	CC State <sup>(1)</sup>	CC (Constant Current) operation selected by shorting Pin 2 to Pin 15 (open collector controlled by a photocoupler (see Figure 3-30). Must be enabled by referring to PAR. 3.4.17.1.3.
3	CP State <sup>(1)</sup>	CP (Constant Power) operation selected by shorting Pin 3 to Pin 16 (open collector controlled by a photocoupler (see Figure 3-30). Must be enabled by referring to PAR. 3.4.17.1.4.
4	CR State <sup>(1)</sup>	CR (Internal Resistance Simulation) operation selected by shorting Pin 4 to Pin 17 (open collector controlled by a photocoupler (see Figure 3-30).
5	ON/OFF State <sup>(1)</sup>	Output is set to ON by shorting Pin 5 to Pin 18 (open collector controlled by a photocoupler (see Figure 3-30).
6	Not used	Not used.
7	EXT CV+	Positive voltage (either 0 ~ 5V d-c or 0 ~ 10V d-c as selected from Menu (see PAR. 3.4.17.1.1) used to set output voltage from 0 to rated maximum)
8	EXT CC+	Positive voltage (either 0 ~ 5V d-c or 0 ~ 10V d-c as selected from Menu (see PAR. 3.4.17.1.1) used to set output current from 0 to rated maximum)
9	EXT CP+	Positive voltage (either 0 ~ 5V d-c or 0 ~ 10V d-c as selected from Menu (see PAR. 3.4.17.1.1) used to set output power from 0 to rated maximum)

(1) Open collector output: Maximum voltage 30V and maximum current 8mA.

**TABLE 3-7. ANALOG CONTROL CONNECTOR PIN FUNCTIONS (CONTINUED)**

PIN No. (FIGURE 3-29)	SIGNAL NAME	FUNCTION
10	EVREF+ (2)	Positive reference voltage, either +5V d-c or +10V d-c as selected from Menu (see PAR. 3.4.17.1.1). May be used to develop programming voltages applied to pins 7, 8 and 9. (see Figure 3-30).
11	V MONITOR	Analog Voltage monitor, use with Pin 23. Either 0 ~ 5V d-c or 0 ~ 10V d-c as selected from Menu (see PAR. 3.4.17.1.1), proportional to output voltage. Must be enabled by referring to PAR. 3.4.17.1.5.
12	A MONITOR	Analog Current monitor, use with Pin 23. Either 0 ~ 5V d-c or 0 ~ 10V d-c as selected from Menu (see PAR. 3.4.17.1.1), proportional to output current. Must be enabled by referring to PAR. 3.4.17.1.5.
13	P MONITOR	Analog Power monitor, use with Pin 23. Either 0 ~ 5V d-c or 0 ~ 10V d-c as selected from Menu (see PAR. 3.4.17.1.1), proportional to output power. Must be enabled by referring to PAR. 3.4.17.1.5.
14 ~ 18	State common	Return for pins 1 through 5 (see Figure 3-30).
19	EXT CV-	Return for pin 7 (see Figure 3-30).
20	EXT CC-	Return for pin 8 (see Figure 3-30).
21	EXT CP-	Return for pin (see Figure 3-30).
22	EVREF- (2)	Return for reference voltage at pin 22. (see Figure 3-30).
23 ~ 25	AGND1	Analog programming signal ground. Return for pins 11, 12 and 13 (see Figure 3-30).

(2) Maximum current 5mA.

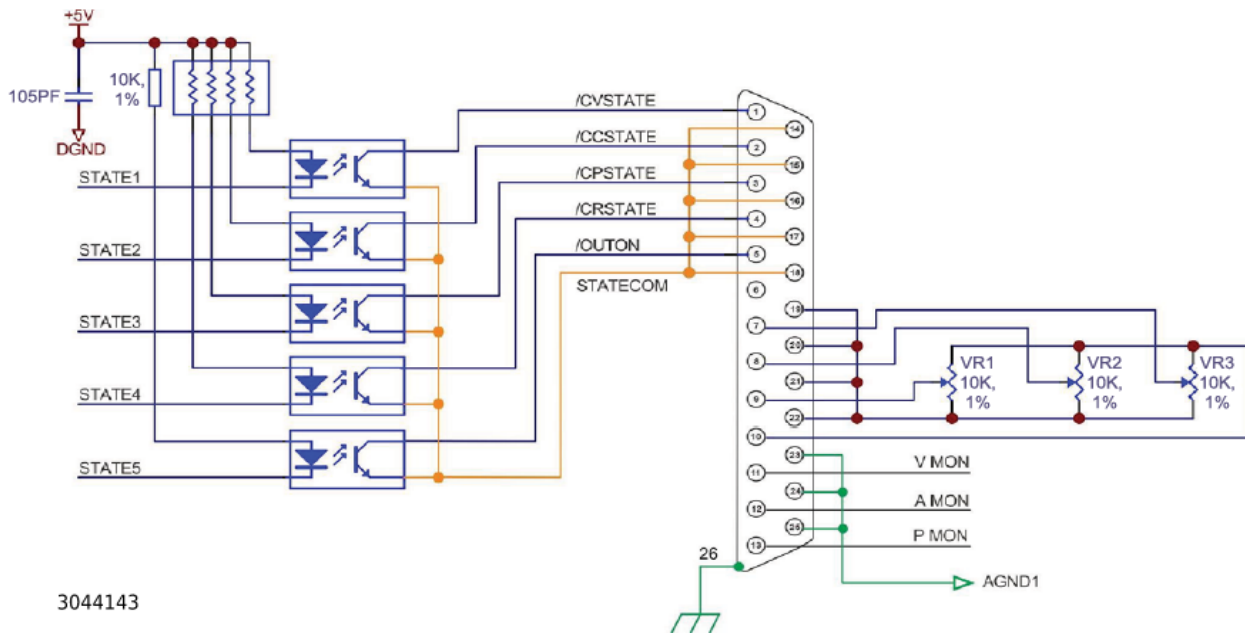
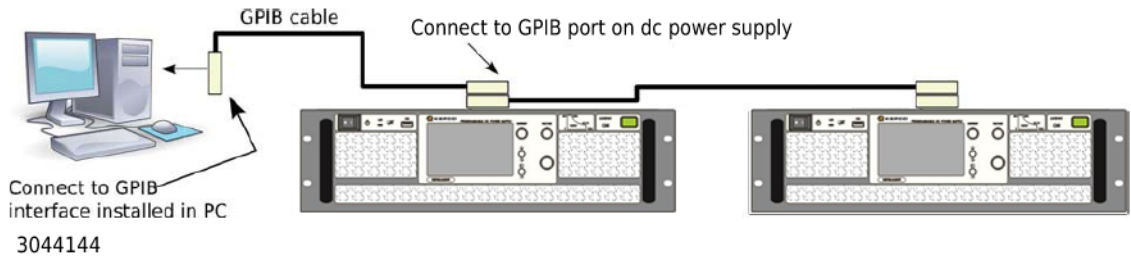

**FIGURE 3-30. ANALOG CONTROL, TYPICAL CONNECTIONS, SCHEMATIC DIAGRAM**

### 3.10.2 IEEE 488.2 (GPIB)

When the IEEE 488.2 (GPIB) interface is installed, KLN EXT Power Supplies may be programmed over the IEEE 488 standard communication bus (General Purpose Interface Bus, GPIB) using SCPI (Standard Commands for Programmable Instruments). SCPI provides a common language conforming to IEEE 488.2 for instruments used in automatic test systems.

Refer to Figure 3-31 for GPIB connections. To change or view the GPIB address, access Menu function E-3-1 (see PAR. 3.4.17.3.1).



**FIGURE 3-31. GPIB CONNECTIONS**

Refer to Table 3-8 for GPIB port input/output signal allocations. All power supply functions available from the front panel can be programmed via remote commands.

**TABLE 3-8. IEEE 488 PORT CONNECTOR (J4) PIN ASSIGNMENTS**

PIN	SIGNAL NAME	FUNCTION
1	DI01	I/O Line
2	DI02	I/O Line
3	DI03	I/O Line
4	DI04	I/O Line
5	EOI	End or Identify
6	DAV	Data Valid
7	NRFD	Not Ready for Data
8	NDAC	Not Data Accepted
9	IFC	Interface Clear
10	SRQ	Service Request
11	ATN	Attention
12	SHIELD	Shield
13	DI05	I/O Line
14	DI06	I/O Line
15	DI07	I/O Line
16	DI08	I/O Line
17	REN	Remote Enable
18	GND	Ground (signal common)
19	GND	Ground (signal common)
20	GND	Ground (signal common)
21	GND	Ground (signal common)
22	GND	Ground (signal common)
23	GND	Ground (signal common)
24	LOGIC GND	Logic Ground

### 3.10.2.1 IEEE 488 (GPIB) BUS PROTOCOL

Table 3-9 defines the interface capabilities of the KLN EXT power supply (Talker/Listener) relative to the IEEE 488 (GPIB) bus (reference document *ANSI/IEEE Std 488: IEEE Standard Digital Interface for Programmable Instrumentation*) communicating with a Host Computer—Controller (Talker/Listener).

**TABLE 3-9. IEEE 488 (GPIB) BUS INTERFACE FUNCTIONS**

FUNCTION	SUBSET SYMBOL	COMMENTS
Source Handshake	SH1	Full Source Handshake
Acceptor Handshake	AH1	Full Acceptor Handshake
Talker	T6	Basic Talker
Listener	L4	Basic Listener
Service Request	SR0	Without Service Request
Remote/Local	RL1	Remote/Local Change
Parallel Poll	PP0	Without Parallel Polling
Device Clear	DC1	Device Clear

### 3.10.3 SERIAL (RS422/RS485) & USB

The optional RS 422/RS 485 and USB Interface can be configured to allow remote operation via any of the three interfaces optional interfaces included. Refer to Figure 3-32 and Table 3-10 for connector and pin functions.

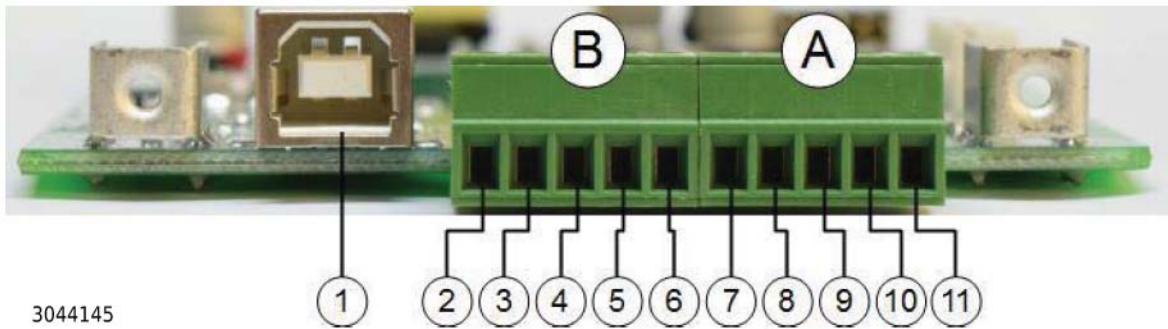

**FIGURE 3-32. RS 422/RS 485 AND USB INTERFACE, CONNECTORS AND PINS**

**TABLE 3-10. RS 422/RS 485, USB INTERFACE CONNECTOR/PIN FUNCTIONS**

SEE FIGURE 3-32	SIGNAL NAME	FUNCTION
1	N/A	USB type B socket
A, B	N/A	Two five-pin connectors, A and B, connected in parallel, used for either RS 422 or RS 485 communication as determined by Mode selection (see PAR. 3.4.17.2.1)
2	(B)RS-422- TX-	Connector B RS 422 Transmit - if RS 422 selected per PAR. 3.4.17.2.1).
3	(B)RS-422- TX+	Connector B RS 422 Transmit + if RS 422 selected per PAR. 3.4.17.2.1).
4	(B)RS-422- RX- / RS-485- D-	Connector B RS 422 Receive - or RS 485 Data - depending on Mode selected (see PAR. 3.4.17.2.1).
5	(B)RS-422- RX+ / RS-485- D+	Connector B RS 422 Receive + or RS 485 Data + depending on Mode selected (see PAR. 3.4.17.2.1).
6	(B)RS-422- GND	Connector B Ground
7	(A)RS-422- TX-	Connector A RS 422 Transmit - if RS 422 selected per PAR. 3.4.17.2.1).
8	(A)RS-422- TX+	Connector A RS 422 Transmit + if RS 422 selected per PAR. 3.4.17.2.1).
9	(A)RS-422- RX- / RS-485- D-	Connector A RS 422 Receive - or RS 485 Data - depending on Mode selected (see PAR. 3.4.17.2.1).
10	(A)RS-422- RX+ / RS-485- D+	Connector A RS 422 Receive + or RS 485 Data + depending on Mode selected (see PAR. 3.4.17.2.1).
11	(A)RS-422- GND	Connector A Ground

**3.10.3.1 RS 422 INTERFACE**

Refer to Figure 3-33 for RS 422 Connections. An adapter (e.g., RS 422 to RS 232 or RS 422 to USB, not supplied) may be required to connect to host computer.

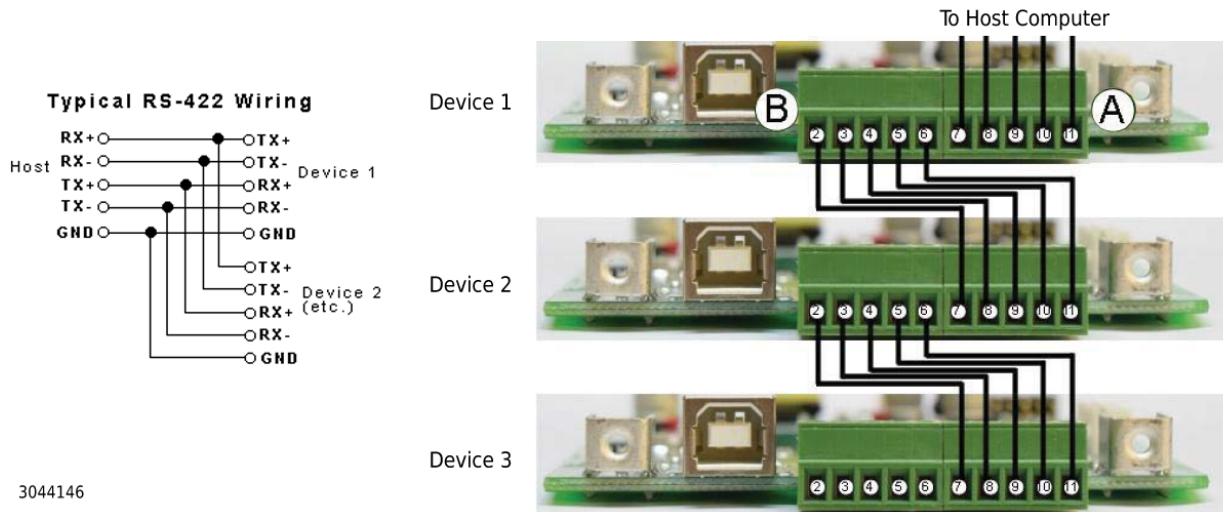

**FIGURE 3-33. RS 422 CONNECTIONS**

### 3.10.3.2 RS 485 INTERFACE

Refer to Figure 3-34 for RS 485 Connections. An adapter (e.g., RS 485 to RS 232 or RS 485 to USB, not supplied) may be required to connect to host computer.

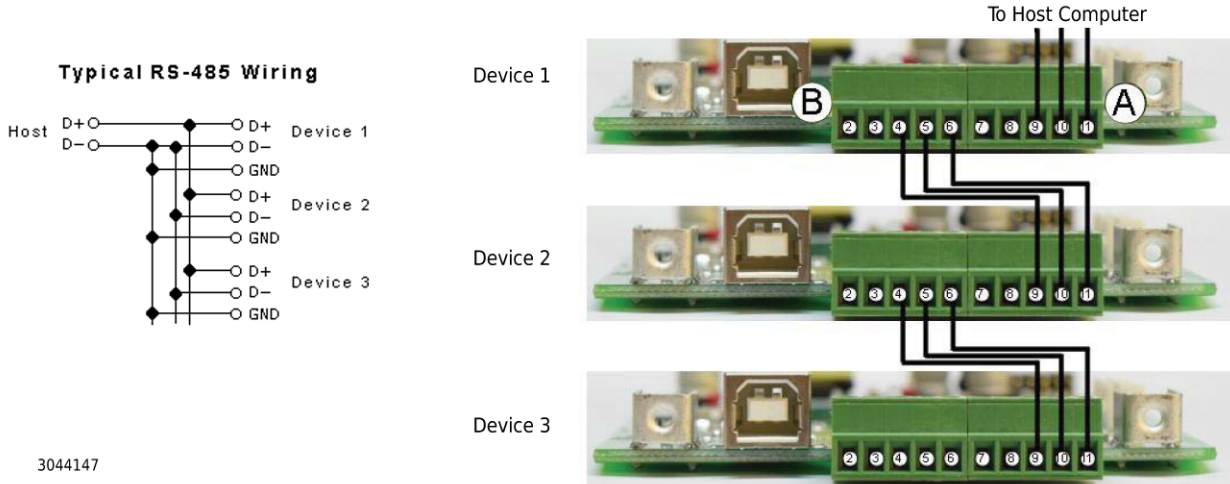

FIGURE 3-34. RS 485 CONNECTIONS

### 3.10.3.3 USB INTERFACE

Use a USB Type A to USB Type B (male) cable to connect the USB socket of the KLN EXT (see Figure 3-32, item 1) to the computer.

Download the driver from the FTDI web site  
<http://www.ftdichip.com/Drivers/D2XX.htm2>.

Install the driver according to per instructions found at:  
<http://www.ftdichip.com/Support/Documents/InstallGuides.htm>

No other settings are required.

## 3.11 OPERATOR MAINTENANCE

Periodic cleaning of the front panel cooling vents is recommended as necessary to prevent dust build-up which could lead to possible overheating.



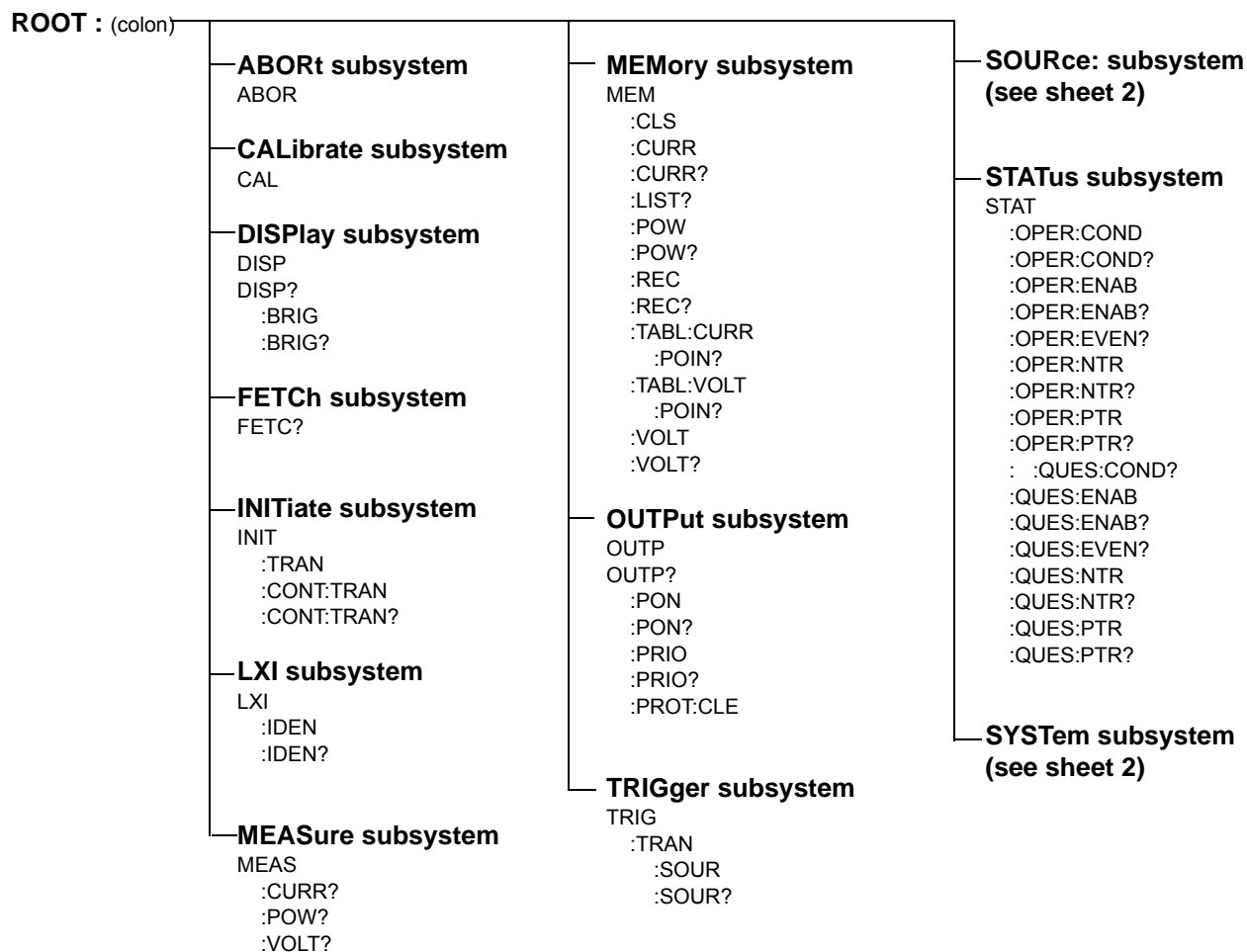
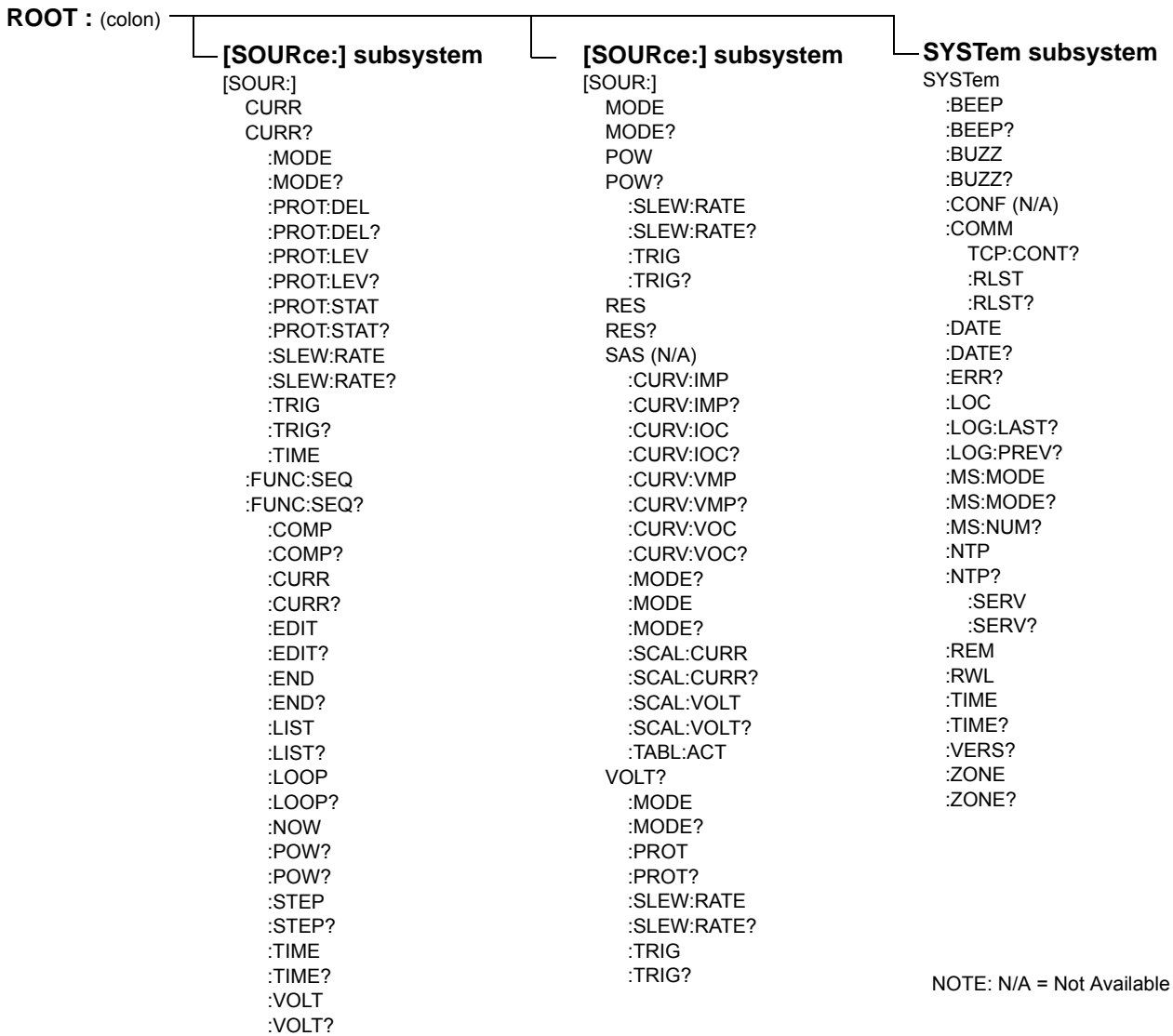

FIGURE 3-35. TREE DIAGRAM OF SCPI COMMANDS USED WITH KLN POWER SUPPLY (SHEET 1 OF 2)



**FIGURE 3-35. TREE DIAGRAM OF SCPI COMMANDS USED WITH KLN POWER SUPPLY (SHEET 2 OF 2)**

## SECTION 4 - CALIBRATION

### 4.1 GENERAL

This section contains the calibration instructions for the Power Supply. It is recommended that the user be familiar with Local Mode operation (PAR. 3.4) before calibrating the unit.

**CAUTION: IT IS RECOMMENDED THAT CALIBRATION BE PERFORMED ONLY BY AUTHORIZED PERSONNEL FAMILIAR WITH ELECTRONIC TEST AND CALIBRATION EQUIPMENT.**

A full calibration consist of a voltage calibration and a current calibration. Both voltage and current calibrations consist of a full scale calibration.

Calibration of the KLN is performed locally using the front panel touchscreen.

NOTE: Calibration of a master/slave configuration requires that both units be restored to standalone operation (see PAR. 3.6.2 or 3.6.4 for instructions) and calibrated individually.

### 4.2 EQUIPMENT REQUIRED

The following equipment is required to calibrate the KLN Power Supply.

- Digital Voltmeter (DVM) with 6 digits resolution and at least 0.002% accuracy for d-c measurements.

NOTE: Because the voltage measured will be used as a reference for calibration, the DVM used must be accurately calibrated prior to calibrating the power supply.

- Precision Shunt Resistor (with a tolerance of 0.01%, power rating of at least 10 times larger than the maximum stress, and a temperature coefficient equal to or better than 20 ppm per degree C).

NOTE: Proper cooling of the external precision shunt resistor ensures the accuracy of the calibration.

### 4.3 PRELIMINARY SETUP

1. Turn off power supply and disconnect load from output terminals at the rear of unit.
2. Verify that power supply is configured for local error sensing (PAR. 2.5.8) and connect unit as shown in Figure 4-1.
3. Connect DVM to points "A" of sense terminal block at the rear of power supply as shown in Figure 4-1.

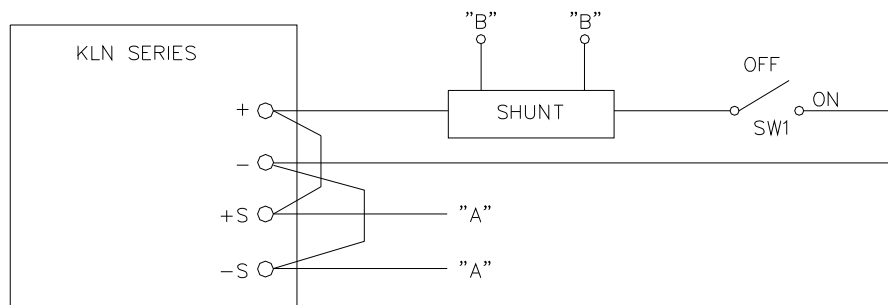

3043671

NOTE: CONNECT DVM TO POINTS "A" OR "B" AS DIRECTED BY PROCEDURE.

**FIGURE 4-1. CALIBRATION SETUP**

4. Refer to Figure 4-1 and set switch SW1 to OFF position.
5. Turn on power to the KLN EXT power supply and allow unit to warm up at least 30 minutes before proceeding.
6. Set output voltage to maximum (105% of rated voltage). E.g., for KLN 80-540E set voltage to 84.000V).
7. Set OVP to 110% of rated voltage. E.g., for KLN 80-540E set OVP to 88.000V).
8. Set output current to maximum (105% of rated current). E.g., for KLN 80-540E set current to 567.00A.
9. Set OCP to 110% of rated current). E.g., for KLN 80-540E set current to 594.00A.

#### 4.4 VOLTAGE CALIBRATION PROCEDURE<sup>(‡)</sup>

After performing the preliminary setup (see PAR. 4.3), proceed as follows to calibrate the voltage ratio. Note that values in brackets [ ] in the following procedure are typical examples for KLN 80-540E.

1. Press **OUTPUT ON** switch at front panel to enable the output.
2. Record voltage shown on front panel display. [For example 84.014V],
3. Record voltage at +S and -S sense terminals using the DVM connected to points "A" as shown in Figure 4-1. [For example, 83.990]
4. Press **OUTPUT ON** switch at front panel to disable the output.
5. Access Calibration via Menu selection C-9 using password 165958 (see Figure 4-2). Enter the password using either the virtual keypad on the touchscreen, then touch ENT key, or use the SELECT encoder and ENTER switch as explained in PAR. 3.3.2.

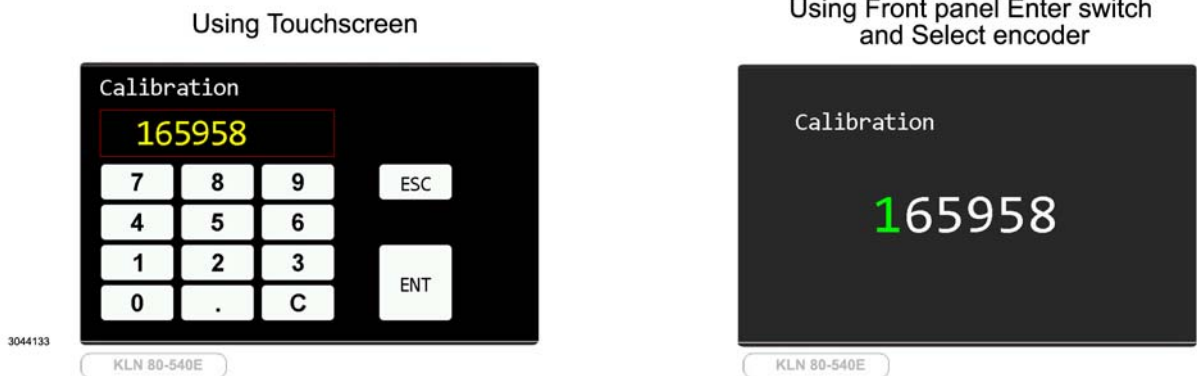

**FIGURE 4-2. ENTERING PASSWORD TO ACCESS CALIBRATION**

- After entering the password, the touchscreen shows selections for **1. Voltage Ratio** and **2. Current Ratio**. Select **1. Voltage Ratio** using either the touch screen or **SELECT** encoder and **ENTER** switch (see Figure 4-3). The previous voltage ratio is displayed.

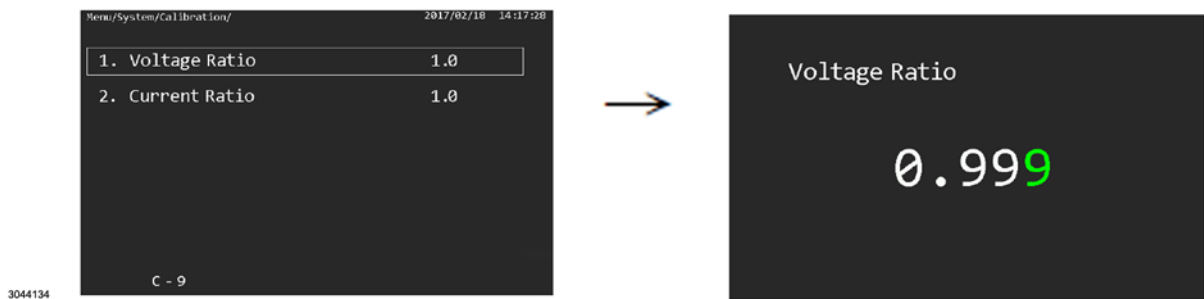

**FIGURE 4-3. VOLTAGE RATIO CALIBRATION**

- Calculate the new Voltage Ratio = DVM reading (step 3) /Front panel reading (step 2). [For example,  $83.990/84.014 = 0.999714$ ]
- Enter the new voltage ratio [0.999] using either the touch screen or **SELECT** encoder and **ENTER** switch.
- Press **ENTER** switch, then press and hold **HOME** switch for at least 1.5 seconds to return to the home screen.
- Turn off power to the unit, disconnect DVM and proceed to Current Calibration (PAR. 4.5).

#### **4.5 CURRENT CALIBRATION PROCEDURE<sup>(†)</sup>**

NOTE: This procedure continues from step 10 of Voltage Calibration procedure above.

- Verify power is off. Connect DVM to points “B” across shunt resistor terminals as shown in Figure 4-1 and set switch SW1 to ON position.
- Turn on power to the unit and press OUTPUT ON switch to enable the output.

3. Record current displayed on front panel.[For example, 566.84A]]
4. Measure voltage across shunt (DVM reading) and use this value to calculate output current using  $I$  (Amperes) =  $E/R$  where  $E$  is the voltage across the shunt (Volts) and  $R$  is the value of the shunt resistor (ohms). Record calculated value. [For example 572.55A]
5. Press OUTPUT ON switch to disable the output.
6. Access Calibration via Menu selection C-9 using password 165958 (see Figure 4-2). Enter the password using either the virtual keypad on the touchscreen, then touch ENT key, or use the SELECT encoder and ENTER switch as explained in PAR. 3.3.2.
7. After entering the password, the touchscreen shows selections for **1. Voltage Ratio** and **2. Current Ratio**. Select **2. Current Ratio** using either the touch screen or **SELECT** encoder and **ENTER** switch (see Figure 4-4). The previous current ratio is displayed.



**FIGURE 4-4. CURRENT RATIO CALIBRATION**

8. Calculate the new Current Ratio = DVM reading (step 4) /Front panel reading (step 3). [For example,  $572.55/566.84 = 1.010073$ ]
9. Enter the new Current Ratio [1.010] using either the touch screen or **SELECT** encoder and **ENTER** switch.
10. Press **ENTER** switch, then press and hold **HOME** switch for at least 1.5 seconds to return to the home screen.
11. Turn off power to the unit, disconnect DVM and disconnect shunt.

## APPENDIX A - SCPI COMMON COMMAND/QUERY DEFINITIONS

### A.1 INTRODUCTION

This appendix defines the SCPI common commands and queries used with the KLN power supply. Common commands and queries are preceded by an asterisk (\*) and are defined and explained in paragraphs A.2 through A.14, arranged in alphabetical order. Table A-1 provides a quick reference of all SCPI common commands and queries used in the Interface Card.

**TABLE A-1. IEEE 488.2 COMMAND/QUERY INDEX**

COMMAND	PAR.	COMMAND	PAR.
*CLS	A.2	*RST	A.11
*ESE. ?	A.3, A.4	*SRE, ?	A.12, A.13
*ESR?	A.5	*TRG	A.14
*IDN?	A.7	*TST?	A.15
*OPC, ?	A.8, A.9	*WAI	A.16
*OPT?	A.10		

### A.2 \*CLS — CLEAR STATUS COMMAND

**\*CLS**

Syntax: \*CLS

Description: **Clears status data.** Clears status data. Clears the following registers without affecting the corresponding Enable Registers: Standard Event Status Register (ESR), Operation Status Event Register, Questionable Status. Event Register, and Status Byte Register (STB). Also clears the Error Queue.

### A.3 \*ESE — EVENT STATUS ENABLE COMMAND

**\*ESE**

Syntax: \*ESE

Description: **Enables Event Status.** Sets bits in the standard event status enable register. See Table A-2.

**TABLE A-2. STANDARD EVENT STATUS ENABLE REGISTER BITS**

CONDITION	OPC	NU	QYE	DDE	EXE	CME	NU	PON
BIT	7	6	5	4	3	2	1	0
VALUE	128	64	32	16	8	4	2	1

CME - COMMAND ERRO. Syntax or semantic error occurred when receiving information  
DDE - DEVICE-DEPENDENTERROR. Data stored in register missing, or error occurred during preliminary checkout.  
EXE - EXECUTION ERROR. Order parameter overflowed or the condition was not right.  
OPC - OPERATION COMPLETE.  
PON - POWER ON. 1 when power supply is reset.  
QYE - QUERY ERROR. Data of output array is missing.  
NU - NOT USED.

### A.4 \*ESE? — EVENT STATUS ENABLE QUERY

**\*ESE?**

Syntax: \*ESE

Description: **Clears status data.** Returns the results of the standard event enable register (see Table A-2). The register is cleared after reading it.

### A.5 \*ESR — EVENT STATUS ENABLE COMMAND

**\*ESE**

Syntax: \*ESE

Description: **Enables Event Status.** Sets bits in the standard event status enable register. See Table A-2.

## A.6 \*ESR? — EVENT STATUS ENABLE QUERY

# \*ESR?

Syntax: \*ESR

Description: **Reads and clears Event Status Enable Register.** Reads and clears event status enable register. See Status Commands (PAR. B.98 through B.113).

## A.7 \*IDN? — IDENTIFICATION QUERY

# \*IDN?

Syntax: \*IDN?  
Return value: Character string

Description: **Identifies the instrument.** This query requests identification. The power supply returns a string which contains the manufacturer name, the model, the serial number and the firmware level. The character string contains the following fields: Identifies the instrument. This query requests identification. The power supply returns a string which contains the manufacturer name, the model, the serial number and the firmware level. The character string contains the following fields: <Manufacturer>, <Model>, <Serial Number>, <Firmware revision> where: <Manufacturer> = Kepco, <Model> = KLN model number, <Serial Number> = SSSSSS <Firmware revision> = n.m, (e.g. 1.0).

## A.8 \*OPC — OPERATION COMPLETE COMMAND

# \*OPC

Syntax: \*OPC

Description: **Generates OPC.** Generates the OPC message in the standard event status register when all pending overlapped operations have been completed (for example, a sweep, or a Default). See Understanding Command Synchronization.

## A.9 \*OPC? — OPERATION COMPLETE QUERY

# \*OPC?

Syntax: \*OPC?

Description: **Indicates when pending operations are complete.** Returns an ASCII “+1” when all pending overlapped operations have been completed. See Understanding Command Synchronization

## A.10 OPTIONAL INTERFACE QUERY

# \*OPC?

Syntax: \*OPT?

Description: **Indicates if there is an optional interface installed.** Returns one of the following:

NONE:	No optional interface installed
R422,USB:	RS422+USB interface is installed
ANALOG:	Isolated analog interface is installed
GPBI:	GPPIB interface is installed.

## A.11 \*RST — RESET COMMAND

# \*RST

Syntax: \*RST

Description: **Resets power supply to the power on default state.** Resets power supply to the power on default state. The power supply output set to power-on default state. After sending \*RST, output voltage is set to 0, output current is set to 0, OVP is set to rated voltage +10% and OCP is set to rated current +10%. It is recommended that this command is always the first command set after remote digital control starts, to ensure that the output is set to zero and control of output on/off is properly enabled.

## A.12 \*SRE — SERVICE REQUEST ENABLE COMMAND

# \*SRE

Syntax: \*SRE

Description: **Enables Service Request.** Before reading a status register, bits must be enabled. This command enables bits in the service request register. The current setting is saved in non-volatile memory. See Status Commands (PAR. B.98 through B.113).



### A.13 \*SRE? — SERVICE REQUEST ENABLE QUERY

## \*SRE?

Syntax: \*SRE

Description: **Reads Service Request Register.** Reads the current state of the service request enable register. The register is cleared after reading it. The return value can be decoded using the table in Status Commands (PAR. B.98 through B.113).

### A.14 \*TRG — TRIGGER COMMAND

## \*TRG

Syntax: \*TRG 1

Description: Triggers the power supply to be set to preprogrammed values of output current, voltage or power. When the trigger is armed (checked by examining WTG bit in Status Operational Condition register), \*TRG or TRIG:TRAN generates a trigger signal. If INIT:TRAN has been executed, the trigger will change the output of the power supply to the output current, power and voltage levels specified by CURR:TRIG, VOLT:TRIG and POW:TRIG commands, respectively, and clear the WTG bit in the Status Operation Condition register. If INIT:CONT:TRAN has been issued, the trigger subsystem is immediately rearmed for subsequent triggers, and the WTG bit is again set to 1.

### A.15 \*TST? — SELF TEST QUERY

## \*TST?

Syntax: \*TST? Returned value: 0 or 1

Description: **Power Supply test.** This query causes the power supply to do a self test and provide the controller with pass/fail results. A 0 is returned if the unit passes the test. A 1 is returned to indicate the unit failed self test.

### A.16 \*WAI — WAIT COMMAND

## \*WAI

Syntax: \*WAI

Description: **Wait for all pending operations to complete.** Configures the instrument's output buffer to wait for all pending operations to complete before executing any additional commands over the interface.



## APPENDIX B - SCPI COMMAND/QUERY DEFINITIONS

### B.1 INTRODUCTION

This appendix defines the SCPI subsystem commands and queries used with the KLN power supply. Subsystem commands are defined in PAR. 3.9.3.1 through 3.9.3.12. Table B-1 provides a quick reference of all SCPI subsystem commands and queries used in the KLN EXT Series.

**TABLE B-1. SCPI SUBSYSTEM COMMAND/QUERY INDEX**

COMMAND	PAR.	COMMAND	PAR.
ABOR	B.3	[SOUR:]CURR:SLEW:RATE, ?	B.49, B.50
DISP, ?	B.4, B.5	[SOUR:]CURR:TRIG, ?	B.51, B.52
DISP:BRIG, ?	B.6, B.7	[SOUR:]FUNC:SEQ, ?	B.53, B.54
FETC?	B.8	[SOUR:]FUNC:SEQ:COMP, ?	B.55, B.56
INIT:TRAN	B.9	[SOUR:]FUNC:SEQ:CURR, ‡	B.57, B.58
INIT:CONT:TRAN, ?	B.10	[SOUR:]FUNC:SEQ:EDIT, ?	B.59, B.60
LX:IDEN	B.11	[SOUR:]FUNC:SEQ:END?	B.61, B.62
MEAS:CURR?	B.12	[SOUR:]FUNC:SEQ:LIST, ?	B.63, B.64
MEAS:POW?	B.13	[SOUR:]FUNC:SEQ:LOOP, ?	B.65, B.66
MEAS:VOLT?	B.14	[SOUR:]FUNC:SEQ:NOW	B.67
MEM:CLS	B.15	[SOUR:]FUNC:SEQ:POW, ?	B.68, B.69
MEM:CURR, ?	B.16, B.17	[SOUR:]FUNC:SEQ:STEP, ?	B.70, B.71
MEM:LIST?	B.18	[SOUR:]FUNC:SEQ:TIME, ?	B.72, B.73
MEM:POW, ?	B.19, B.20	[SOUR:]FUNC:SEQ:VOLT, ?	B.74, B.75
MEM:REC, ?	B.21, B.22	[SOUR:]MODE, ?	B.76, B.77
MEM:TABL:CURR	B.23	[SOUR:]POW, ?	B.78, B.79
MEM:TABL:CURR:POIN?	B.24	[SOUR:]POW:SLEW:RATE, †, ?	B.82, B.83
MEM:TABL:VOLT	B.27,	[SOUR:]RES, ?	B.84, B.85
MEM:TABL:VOLT:POIN?	B.28	[SOUR:]TIME, ?	B.86, B.87
OUTP, ?	B.29, B.30	[SOUR:]VOLT, ?	B.88, B.89
OUTP:PON, ?	B.31, B.32	[SOUR:]VOLT:MODE, ?	B.90, B.91
OUTP:PRIO, ?	B.33, B.34	[SOUR:]VOLT:PROT, ?	B.92, B.93
OUTP:PROT:CLE	B.35	[SOUR:]VOLT:SLEW:RATE, ?	B.94, B.95
TRIG:TRAN	B.36	[SOUR:]VOLT:TRIG, ?	B.96, B.97
TRIG:TRAN:SOUR, ?	B.37, B.38	STAT:OPER:COND?	B.98
[SOUR:]CURR[:LEV][:IMM][:AMP], ?	B.39, B.40	STAT:OPER:ENAB, ?	B.99, B.100
[SOUR:]CURR:MODE, ?	B.41, B.42	STAT:OPER:EVEN?	B.101
[SOUR:]CURR:PROT:DEL, ?	B.43, B.44	STAT:OPER:NTR, ?	B.102, B.103
[SOUR:]CURR:PROT:LEV, ?	B.45, B.46	STAT:OPER:PTR, ?	B.104, B.105
[SOUR:]CURR:PROT:STAT, ?	B.47, B.48	STAT:QUES:COND?	B.106

**TABLE B-1. SCPI SUBSYSTEM COMMAND/QUERY INDEX (CONTINUED)**

COMMAND	PAR.	COMMAND	PAR.
STAT:QUES:ENAB, ?	B.107, B.108	SYSTEM:LOG:LAST?	B.124
STAT:QUES:EVEN?	B.109	SYSTEM:LOG:PREV?	B.125
STAT:QUES:NTR, ?	B.110, B.111	SYSTEM:MS:MODE, ?	B.126, B.127
STAT:QUES:NPR, ?	B.112, B.113	SYSTEM:MS:NUM, ?	B.128, B.128
SYSTEM:BEEP, ?	B.114, B.115	SYSTEM:NTP, ?	B.129, B.130
SYSTEM:BUZZ, ?	B.116, B.117	SYSTEM:NTP:SERV, ?	B.131, B.132
SYSTEM:COMM:RLST, ?	B.118,	SYSTEM:REM	B.133
SYSTEM:COMM:TCP:CONT?	B.119	SYSTEM:RWL	B.134
SYSTEM:DATE, ?	B.120, B.121	SYSTEM:TIME, ?	B.135, B.136
SYSTEM:ERR?	B.122	SYSTEM:VERS?	B.137
SYSTEM:LOC	B.123	SYSTEM:ZONE, ?	B.138, B.139

**B.2 NUMERICAL VALUES**

<NR1> Refers to integer

<NRf+> For queries this refers to Floating (scientific notation: digits with decimal point and Exponent, e.g., 2.71E1 for 27.1.) For commands this generally refers to a decimal value, e.g., 27.1

<Bool> Boolean Data. Can be numeric (0, 1), or named (OFF, ON).

<address> Network address, Examples: 192.168.0.1<NR1> Refers to integer

<String> String program data.

**B.3 ABORt:TRANSient COMMAND**

**ABOR:TRAN**

Syntax:Short Form: ABOR:TRANS

Long Form: ABORt:TRANSient

Description:**Aborts Transient mode.** Cancels previously armed trigger, resets WTG. Sending ABOR:TRAN disarms the trigger system so subsequent trigger commands have no effect. If INIT:CONT:TRANS ON has been programmed, this command has no effect. Related Commands: INIT, \*TRG.

Argument:None

Example:ABOR ON cancels pending transients

**B.4 DISPlay COMMAND (†)**

**DISP**

Syntax:Short Form: DISP:CONT {ON | OFF | 1 | 0 }

Long Form: DISPlay:CONTRast { ON | OFF | 1 | 0 }

Description:**Sets the display back light on or off**

Argument:0 or OFF turns the back light off  
1 or ON turns the back light on

Example:DISP ON sets display back light on.

**B.5 DISPlay? QUERY (†)**

**DISP?**

Syntax:Short Form: DISP?

Long Form: DISPlay?

Description:**Returns 1 or 0 to indicate back light is on (1) or off (0).**

Return Format:<boolean>

## B.6 DISPlay:BRIGhtness COMMAND (†)

## DISP:BRIG

Syntax:Short Form: DISP:BRIG <NR1>

Long Form: DISPlay:BRIGhtness <NR1>

Description:**Sets the brightness of front panel touchscreen display.**

Argument:<NR1> is a value in the range from 1 (dimpest) to 9 (brightest).

Example:DISPlay:BRIGhtness 9 sets display contrast to level 9 (brightest).

## B.7 DISPlay:BRIGhtness? QUERY (†)

## DISP:BRIG?

Syntax:Short Form: DISP:BRIG?

Long Form: DISPlay:BRIGhtness?

Description:**Returns the brightness level set by DISP:BRIG.**

Return Format:<NR1>

## B.8 FETCh? QUERY

## FETC?

Syntax:Short Form: FETC?

Long Form: FETCh?

Description:**Measures actual output voltage and current.** The query performs a measurement and returns the corresponding values of DC output current in Amperes, DC output voltage in Volts and output power in Watts.

Return Format:<NRf+>

Example:FETC? returns 1.41000E+1, 3.00100E-0, 4.2E+1 (Voltage is 14.1V, current is 3.001A and power is 42W).

## B.9 INITiate:TRANsient COMMAND

## INIT:TRAN

Syntax:Short Form: INIT:TRAN

Long Form: INITiate:TRANsient

Description:**Initiates Transient mode.** once initiated the VOLTage:TRIGgered, CURRent:TRIGgered and POWER:TRIGgered commands are applicable. Re-initiate the transient mode after each trigger as long as transient mode is not set to continuous (see PAR. B.36 for details).

Example:INIT:TRAN initiates transient mode, enabling VOLTage:TRIGgered, CURRent:TRIGgered and POWER:TRIGgered commands to function.

## B.10 INITiate:CONTInuous:TRANsient COMMAND

## INIT:CONT:TRAN

Syntax:Short Form: INIT:CONT:TRAN { ON | OFF | 1 | 0 }

Long Form: INITiate:CONTInuous:TRANsient { ON | OFF | 1 | 0 }

Description:**Initiates Continuous Transient mode.** Once initiated, transient mode does not need to be reinitiated. the transient mode after each trigger as long as transient mode is not set to continuous. (see PAR. B.36 for details).

Argument:0 or OFF disables continuous transient mode.  
1 or ON sets transient mode to continuous

Example:INIT:CONT:TRAN turns on continuous transient mode.

## B.11 LXI:IDENtify COMMAND

## LXI:IDEN

Syntax:Short Form: LXI:IDEN { ON | OFF | 1 | 0 }

Long Form: LXI:IDENtify { ON | OFF | 1 | 0 }

Description:**Identify remote-controlled unit.** This command causes the LAN indicator on the front panel of the unit to blink. LXI:IDEN ON

Argument:1 or ON starts the front panel LAN indicator blinking.  
0 or OFF stops the front panel LAN indicator from blinking.

Example:LXI:IDEN 1 causes front panel LAN indicator to blink.

**B.12 MEASure[:SCALar]:CURRent[:DC]? QUERY****MEAS:CURR?**

Syntax:Short Form: MEAS:CURR?

Long Form: MEASure[:SCALar]:CURRent[:DC]?

Description:**Returns 5 significant digits in floating format representing output current in amperes.**

Return Format:&lt;NRf+&gt; (Current in amperes)

Example:MEAS:CURR? returns 1.2502E+01 for output current of 12.502A (front panel Current display shows 12.50).

**B.13 MEASure[:SCALar]:POWer[:DC]? QUERY<sup>(†)</sup>****MEAS:POW?**

Syntax:Short Form: MEAS:POW?

Long Form: MEASure[:SCALar]:POWer[:DC]?

Description:**Returns 5 significant digits in floating format representing output power in watts.**

Return Format:&lt;NRf+&gt; (Power in watts)

Example:MEAS:POW? returns 45500E+01 for output power of 45.50W,

**B.14 MEASure[:SCALar]:VOLTage[:DC]? QUERY****MEAS:VOLT?**

Syntax:Short Form: MEAS:VOLT?

Long Form: MEASure[:SCALar]:VOLTage[:DC]?

Description:**Returns 5 significant digits in floating format representing output voltage in volts.**

Return Format:&lt;NRf+&gt; (Voltage in volts)

Example:MEAS:VOLT? returns 2.5005E+01 for output voltage of 25.005V (front panel Voltage display shows 25.00).

**B.15 MEMory:CLS COMMAND****MEM:CLS**

Syntax:Short Form: MEM:CLS

Long Form: MEMory:CLS

Description:**Clears all locations used to store three sets of power supply settings (voltage, current, power, time).**

Example:MEM:CLS clears all power supply settings storage locations.

**B.16 MEMory:CURRent COMMAND****MEM:CURR**

Syntax:Short Form: MEM:CURR&lt;NR1&gt; &lt;NRf+&gt;

Long Form: MEMory:CURRent&lt;NR1&gt; &lt;NRf+&gt;

Description:**Stores a current value to one of three storage locations.**

Argument:&lt;NR1&gt; is a number from 1 to 3 representing one of three storage locations.

&lt;NRf+&gt; is the current value (Amperes) to be stored. Must be within range of 0 to 105% of unit's rated current.

Example:MEM:CURR2 312 stores current value of 312 Amperes in storage location 2.

**B.17 MEMory:CURRent? QUERY****MEM:CURR?**

Syntax:Short Form: MEM:CURR&lt;NR1&gt;?

Long Form: MEMory:CURRent&lt;NR1&gt;?

Description:**Returns value of current in Amperes <NRf+> stored in location <NR1>.**

Return Format: &lt;NRf+&gt; where

&lt;NR1&gt; is a number from 1 to 3 representing one of three storage locations.

&lt;NRf+&gt; is the stored current value.

Example:MEM:CURR? returns 3.12E+2 showing the Current value in location 2 is 312 Amperes.

## B.18 MEMory:LIST? QUERY

## MEM:LIST?

Syntax:Short Form: MEM:LIST?<NR1> <current>,<voltage>,<power>  
Long Form: MEMory:LIST?<NR1> <current>,<voltage>,<power>

Description:**Returns values of current, voltage and power stored in location defined by <NR1>.**

Return Format:<current>,<voltage>,<power> where  
<current> is the value of current in scientific notation (Amperes) stored in location <NR1>.  
<voltage> is the value of voltage in scientific notation (Volts) stored in location <NR1>.  
<power> is the value of power in scientific notation (Watts) stored in location <NR1>.  
<NR1> is a number from 1 to 3 representing one of three storage locations.

Example:MEM:LIST2? returns 3.00100E-0,1.41000E+1, 4.2E+1 (current is 3.001A, voltage is 14.1V, and power is 42W)

## B.19 MEMory:POWer COMMAND<sup>(†)</sup>

## MEM:POW

Syntax:Short Form: MEM:POW<NR1> <NRf+>  
Long Form: MEMory:POWer<NR1> <NRf+>

Description:**Stores a power value to one of three storage locations.**

Argument:<NR1> is a number from 1 to 3 representing one of three storage locations.  
<NRf+> is the power value (Watts) to be stored. Must be within range of 0 to 102% of unit's rated power.

Example:MEM:POW1 4500 stores current value of 4500 Amperes in storage location 1.

## B.20 MEMory:POWer? QUERY<sup>(†)</sup>

## MEM:POW?

Syntax:Short Form: MEM:POW<NR1>? Long Form: MEMory:POWer<NR1>?

Description:**Returns value of power in Watts <NRf+> stored in location <NR1>.**

Return Format: <NRf+> where  
<NR1> is a number from 1 to 3 representing one of three storage locations.  
<NRf+> is the stored power value

Example:MEM:POW1? returns 4.5E+3 showing the Power value in location 1 is 4500 Watts.

## B.21 MEMory:RECall COMMAND

## MEM:REC

Syntax:Short Form: MEM:REC<NR1>  
Long Form: MEMory:RECall<NR1>

Description:**Restores power supply settings to the voltage, current, power and time values stored in memory location defined by <NR1>.** If the output is off, the recalled values are shown on the front panel Voltage, Current, Power and Time displays. If the output is on, the output changes to the recalled voltage current and power values for the specified time duration. The recalled values are also shown on the front panel Voltage, Current, Power and Time displays.

Argument:<NR1> is a number from 1 to 3 representing one of three storage locations.

Example:MEM:REC1 recalls the values of voltage, current, power and time stored in location 1. If location 1 contains previously stored values of 500V, 25A, 15000W and 10 seconds, these values appear on the front panel display if the output is OFF. If the output is ON, the voltage, current and power values also appear at the output for 10 seconds.

## B.22 MEMory:RECall? QUERY

## MEM:REC?

Syntax:Short Form: MEM:REC?<NR1> Long Form: MEMory:RECall?<NR1>

Description:**Returns number of memory location to be restored by MEM:REC command.**

Return Format:<<NR1> is a number from 1 to 3 representing one of three storage locations.

Example:If location 1 stored 650V, 23A and 5000W, MEM:REC?1 returns 6.5E+2,2.3E+1,5E+3.

### B.23 MEMory:TABLE:VOLTage COMMAND

## MEM:TAB:VOLT

Syntax:Short Form: MEM:TAB:VOLT<NRf+>

Long Form: MEMory:TABLE[:SASimulator]:VOLTage[:AMPLitude] <NRf+>

Description:**NOT APPLICABLE. Sets voltage defined by <NRf+ to SAS table.>**

Argument:<NRf+> is a value in the range from 0 to rated voltage of unit.

Example:MEM:TAB:VOLT 650 sets the SAS Table voltage to 650V

### B.24 MEMory:TABLE[:SASimulator]:VOLTage:POINts? QUERY MEM:TAB:VOLT:POIN?

Syntax:Short Form: MEM:TAB:VOLT:POIN?

Long Form: MEMory:TABLE[:SASimulator]:VOLTage:POINts?

Description:**NOT APPLICABLE. Returns the numbers for set voltage in SAS table.**

Return Format:

Example:MEM:TAB:VOLT:POIN?

### B.25 MEMory:TIME COMMAND

## MEM:TIME

Syntax:Short Form: MEM:TIME<NR1> <NRf+>

Long Form: MEMory:TIME<NR1> <NRf+>

Description:**Stores an output ON time value to one of three storage locations.**

Argument:<NR1> is a number from 1 to 3 representing one of three storage locations.

<NRf+> is the time value (seconds) to be stored. Must be within range of 0.0 to 99999.9 seconds

Example:MEM:TIME2 60000 stores output ON time value of 60000 seconds in storage location 2.

### B.26 MEMory:TIME? QUERY

## MEM:TIME?

Syntax:Short Form: TIME:POW<NR1>?

Long Form: MEMory:TIME<NR1>?

Description:**Returns value of Output ON time in seconds <NRf+> stored in location <NR1>.**

Return Format: <NRf+> where

<NR1> is a number from 1 to 3 representing one of three storage locations.

<NRf+> is the stored output ON time value

Example:MEM:POW2? returns 6E+4 showing the output ON time value in location 2 is 60000 seconds.

### B.27 MEMory:VOLTage COMMAND

## MEM:VOLT

Syntax:Short Form: MEM:VOLT<NR1> <NRf+>

Long Form: MEMory:VOLTage<NR1> <NRf+>

Description:**Stores a voltage value to one of three storage locations.**

Argument:<NR1> is a number from 1 to 3 representing one of three storage locations.

<NRf+> is the voltage value (Volts) to be stored. Must be within range of 0 to 105% of unit's rated voltage.

Example:MEM:VOLT3 622 stores voltage value of 622 Volts in storage location 3.

### B.28 MEMory:VOLTage? QUERY

## MEM:VOLT?

Syntax:Short Form: MEM:VOLT<NR1>?

Long Form: MEMory:VOLTage<NR1>?

Description:**Returns value of voltage in Volts <NRf+> stored in location <NR1>.**

Return Format:<NRf+> where

<NR1> is a number from 1 to 3 representing one of three storage locations.

<NRf+> is the stored voltage value.(Volts)

Example:MEM:VOLT3? returns 6.22E+2 showing the Voltage value in location 3 is 622 Volts.



## OUTP

### B.29 OUTPut COMMAND

Syntax: Short Form: OUTP { ON | OFF | 1 | 0 } <bool>  
Long Form: OUTPut { ON | OFF | 1 | 0 } <bool>

Description: **Enables or disables the power supply output.**

To enable DC power supply output: <ON> or 1. To disable DC power supply output: <OFF> or 0.

Argument: <ON> or 1 to enable power supply output  
<OFF> or 0 to disable power supply output

Example: OUTP ON enables the DC output of the power supply.

## OUTP?

### B.30 OUTPut? QUERY

Syntax: Short Form: OUTP? Long Form: OUTPut?

Description: **Indicates whether power supply output is enabled or disabled.** Returns 0 if output disabled, returns 1 if output enabled.

Return Format: { 1 | 0 }

Example: OUTP? returns 1 (the DC output of the power supply is enabled).

## OUTP:PON

### B.31 OUTPut:PON COMMAND

Syntax: Short Form: OUTP:PON { OFF | LAST } Long Form: OUTPut:PON { OFF | LAST }

Description: **Determines power up status of output and operation of OUTP command after power up or recovery from mains loss.** When set to OFF (recommended), the power supply will power up with output off; output on/off can be controlled with OUTP command. When set to LAST (NOT recommended), the power supply will return to the output setting (on or off) in effect when power turned off or lost. If output was off, unit powers up with output off. If output was on, unit powers up with output on, however OUTP command can no longer turn the output off and \*RST is required to set output off.

Argument: <OFF> Programs the unit to output off upon power up or recovery from mains loss.  
<LAST> Programs the unit to output on/off setting in effect just before the unit was turned off.

Example: OUTP:PON OFF Programs the unit to output off state upon power up or recovery from mains loss and allows OUTP command to set output to on or off.

## OUTP:PON?

### B.32 OUTPut:PON? QUERY

Syntax: Short Form: OUTP:PON? Long Form: OUTPut:PON?

Description: **Indicates power up status of output and operation of OUTP command after power up or recovery from mains loss.** Returns OFF if unit set to power up with output disabled, returns LAST if unit set to power up with output set to setting in effect before unit was turned off

Return Format: { OFF | LAST }

Example: OUTP:PON? returns OFF (the unit will power up with output off).

## OUTP:PRIO

### B.33 OUTPut:PRIOrity COMMAND

Syntax: Short Form: OUTP:PRIO { CV | CC | CP }  
Long Form: OUTPut:PRIOrity { CV | CC | CP }

Description: **Sets the prevailing operating mode.**

Argument: <CV> Sets Constant Voltage (CV) operating mode as the priority.  
<CC> Sets Constant Current (CC) operating mode as the priority.  
<CP> Sets Constant Power (CP) operating mode as the priority.

Example: OUTP ON enables the DC output of the power supply.

### B.34 OUTPUT:PRIOrity? QUERY

## OUTP:PRIO?

Syntax:Short Form: OUTP:PRIO?

Long Form: OUTPut:PRIOrity?

Description:**Indicates which operating mode is set as priority.** Returns CV, CC, or CP to identify Constant Voltage, Constant Current, or Constant Power, respectively, as the priority operating mode,

Return Format:{ CV | CC| CP }

Example:OUTP:PRIO? returns CV to indicate Constant Voltage is the priority operating mode.

### B.35 OUTPUT:PROTection:CLEar COMMAND

## OUTP:PROT:CLE

Syntax:Short Form: OUTP:PROT:CLE

Long Form: OUTPut:PROTection:CLEar

Description:**Clears the latched signals that have disabled the output.** Overvoltage, overcurrent, overpower, overtemperature and AC-fail conditions are always latched. All conditions that generate the fault must be removed before the latch can be cleared. The output is then restored to the state it was in before the fault condition occurred.

Argument:None.

Example:OUTP:PROT:CLE clears the latched signals that have disabled the output.

### B.36 TRIGger:TRANsient[:IMMediate] COMMAND

## TRIG:TRAN

Syntax:Short Form: TRIG:TRAN

Long Form: TRIGger:TRANsient[:IMMediate]

Description:**Triggers the transient.** Triggers the power supply to be set to preprogrammed values of output current, voltage or power. When the trigger is armed (checked by examining WTG bit in Status Operational Condition register), \*TRG or TRIG:TRAN generates a trigger signal. If INIT:TRAN has been executed, the trigger will change the output of the power supply to the output current and voltage levels specified by CURR:TRIG and VOLT:TRIG commands, respectively, and clear the WTG bit in the Status Operation Condition register. If INIT:CONT:TRAN has been issued, the trigger subsystem is immediately rearmed for subsequent triggers, and the WTG bit is again set to 1.

Argument:None.

Example:TRIG:TRAN triggers the transient.

### B.37 TRIGger:TRANsient:SOURce COMMAND

## TRIG:TRAN:SOUR

Syntax:Short Form: TRIG:TRAN:SOUR BUS

Long Form: TRIGger:TRANsient:SOURce BUS

Description:**Sets the source of the trigger.** At present only BUS (digital interface) is permitted.

Argument:BUS establishes the trigger source as the digital interface.

Example:TRIG:TRAN:SOUR BUS sets the source for the trigger as the digital interface.

### B.38 TRIGger:TRANsient:SOURce? QUERY

## TRIG:TRAN:SOUR?

Syntax:Short Form:TRIG:TRAN:SOUR?

Long Form: TRIGger:TRANsient:SOURce?

Description:**Indicates the source of the trigger.**

Return Format:BUS

Example:TRIG:TRAN:SOUR? returns BUS to indicate the source for the trigger is the digital interface.

**B.39 [SOURCE:]CURRENT[:LEVEL][:IMMEDIATE][:AMPLITUDE] COMMAND****CURR**

Syntax: Short Form: CURR <NRf+> { MIN | MAX }

Long Form: [SOURCE:]CURRENT[:LEVEL][:IMMEDIATE][:AMPLITUDE] <NRf+> { MIN | MAX }

Description: **Sets the output current value.** Maximum output current is rated current; minimum current is zero.

Argument: <NRf+> is a value in the range from 0 to rated current of unit. Rated voltage and current are defined by model (e.g., for KLN 650-23E, rated voltage is 650V, rated current is 23A).

<MIN> is 0

<MAX> is 105% of rated current of unit

Example: For KLN 650-23E CURR 22 sets output current value to 22A, CURR MAX sets output current value to 24.15A?

**B.40 [SOURCE:]CURRENT[:LEVEL][:IMMEDIATE][:AMPLITUDE]? QUERY****CURR?**

Syntax: Short Form: CURR?

Long Form: [SOURCE:]CURRENT[:LEVEL][:IMMEDIATE][:AMPLITUDE]?

Description: **Indicates programmed output current (in amperes).**

Return Format: <NRf+>

Example: CURR? returns 2.2000E+01 to indicate output current is programmed to 22A.

**B.41 [SOURCE:]CURRENT:MODE COMMAND****CURR:MODE**

Syntax: Short Form: CURR:MODE { FIX | STEP }

Long Form: [SOURCE:]CURRENT:MODE { FIX | STEP }

Description: **Determines whether output current is set using CURR command (FIX) or CURR:TRIG command (STEP).**

Argument: <FIX> output current can only be set using CURR command

<STEP> output current can only be set using CURR:TRIG command

Example: CURR:MODE FIX requires that output current be set using CURR command.

**B.42 [SOURCE:]CURRENT:MODE? QUERY****CURR:MODE?**

Syntax: Short Form: CURR:MODE?

Long Form: [SOURCE:]CURRENT:MODE?

Description: **Indicates how current is to be programmed.** Either CURR commands (FIX) or CURR:TRIG commands (STEP) determined the value of output current.

Return Format: either FIX (use CURR command to set output current) or STEP (execute trigger to set current to value determined by CURR:TRIG command).

Example: CURR:MODE? returns FIX indicating CURR must be used to set output current.

**B.43 [SOURCE:]CURRENT:PROTECTION:DELAY COMMAND****CURR:PROT:DEL**

Syntax: Short Form: CURR:PROT:DEL <NRf+>

Long Form: [SOURCE:]CURRENT:PROTECTION:LEVEL <NRf+>

Argument: <NRf+> is a value in a range from 0.005 to 65.535 Seconds

Description: **Sets delay time in Seconds before overcurrent protection (OCP) trips.**

Example: CURR:PROT:DEL 0.01 sets the delay time to 0.01 second before OCP trips.

**B.44 [SOURCE:]CURRENT:PROTECTION:DELAY? QUERY****CURR:PROT:DEL?**

Syntax: Short Form: CURR:PROT:DEL?

Long Form: [SOURCE:]CURRENT:PROTECTION:DELAY?

Description: **Indicates programmed overcurrent protection (OCP) level for output current (in amperes).**

Return Format: <NRf+>

Example: CURR:PROT:DEL? returns 2.75000E+01 to indicate overcurrent protection delay is programmed to 2.75 seconds.

**B.45 [SOURCE:]CURRENT:PROTECTION:LEVEL COMMAND****CURR:PROT:LEV**

Syntax: Short Form: CURR:PROT:LEV <NRf+> { MAX }

Long Form: [SOURCE:]CURRENT:PROTECTION:LEVEL <NRf+> { MAX }

Argument: <NRf+> is a value in the range from 10% to 110% of rated current.

MAX is 110% of rated current of unit

Description: **Sets the overcurrent protection (OCP) value (in amperes).** OCP values set using this command are in effect once the unit is returned to local operation. Maximum value is 110% of rated current. MIN sets OCP to be 10% of rated current. \*RST sets SOUR:CURR:PROT:LEV to maximum value.

Example: CURR:PROT:LEV MAX sets the overcurrent protection level to 25.3A. This is the maximum value if the unit is a 650V, 23A model. SOUR:CURR:PROT:LEV MIN sets the overcurrent protection level to be 2.3A if the unit is a 650V, 23A model.

**B.46 [SOURCE:]CURRENT:PROTECTION:LEVEL? QUERY****CURR:PROT:LEV?**

Syntax: Short Form: CURR:PROT:LEV?

Long Form: [SOURCE:]CURRENT:PROTECTION:LEVEL?

Description: **Indicates programmed overcurrent protection (OCP) level for output current (in amperes).**

Return Format: <NRf+>

Example: CURR:PROT:LEV? returns 2.75000E+01 to indicate overcurrent protection level is programmed to 27.5A.

**B.47 [SOURCE:]CURRENT:PROTECTION:STATE COMMAND****CURR:PROT:STAT**

Syntax: Short Form: VOLT:PROT:STAT <bool> {ON | OFF}

Long Form: [SOURCE:]CURRENT:PROTECTION:STATE <bool> {ON | OFF}

Argument: 1 or ON enables the current protection circuit

0 or OFF disables the foldback circuit for current protection

Description: **Controls whether the output Current Protection (OCP) circuit is enabled.** The protection circuit turns the output off if the power supply is operating in constant current mode and current exceeds the programmed value of CURR:PROT:LEV.

Example: CURR:PROT:STAT 1 enables the current protection.

**B.48 [SOURCE:]CURRENT:PROTECTION:STATE? QUERY****CURR:PROT:STAT?**

Syntax: Short Form: CURR:PROT:STAT?

Long Form: [SOURCE:]CURRENT:PROTECTION:STATE?

Description: **Indicates state of overcurrent protection (OCP)**

Return Format: <bool> 1 = enabled, 0 = disabled

Example: CURR:PROT:LEV? returns 0 to indicate OCP protection is disabled.

**B.49 [SOURCE:]CURRENT:SLEW:RATE COMMAND****CURR:SLEW:RATE**

Syntax:Short Form: CURR:SLEW:RATE <NR1> {MIN | MAX}  
 Long Form: [SOURCE:]CURRENT:SLEW:RATE <NR1> {MIN | MAX}

Argument:< NRf+> is a numerical value (A/mS), setting range varies by model.  
 MIN sets the slew rate to 0.1% of rated current/ms.  
 MAX sets the slew rate to rated current/ms.

Description:This command sets the slew rate (the rate at which current changes from the existing value to the new programmed value) for all programmed changes of output current. MIN sets the slew rate to 0.1% of rated current/ms. MAX sets the slew rate to rated current/ms. Default is MAX.

Example:CURR:SLEW:RATE 50 sets the slew rate to 50A/mS, For KLN 80-180E e.g., CURR:SLEW:RATE MIN sets the slew rate to 0.018A/ms, CURR:SLEW:RATE MAX sets the slew rate to 180A/ms.

**B.50 [SOURCE:]CURRENT:SLEW:RATE? QUERY****CURR:SLEW:RATE?**

Syntax:Short Form: CURR:SLEW:RATE? Long Form: [SOURCE:]CURRENT:SLEW:RATE?

Description:**Indicates state of overcurrent protection (OCP)**

Return Format: <NR1> is the current slew rate setting (A/mS)

Example:CURR:SLEW:RATE? returns 10 to indicate current slew rate is 10A/mS.

**B.51 [SOURCE:]CURRENT[:LEVEL]:TRIGGERED COMMAND****CURR:TRIG**

Syntax:Short Form: CURR:TRIG <NRf+> { MIN | MAX }  
 Long Form: [SOURCE:]CURRENT[:LEVEL]:TRIGGERED <NRf+> { MIN | MAX }

Description:**Sets the output current value after trigger has been executed.** See PAR. B.36 for details. Maximum output current is 105% of rated current; minimum current is zero.

Argument: <NRf+> is a value in the range from 0 to rated current of unit.  
 <MIN> is 0.  
 <MAX> is 105% of rated current of unit.

Example:CURR:TRIG 22 sets output current value to 22A after trigger executed, For KLN 650-23E CURR MAX sets output current value to 24.15A after trigger executed.

**B.52 [SOURCE:]CURRENT[:LEVEL]:TRIGGERED? QUERY****CURR:TRIG?**

Syntax:Short Form: CURR:TRIG?  
 Long Form: [SOURCE:]CURRENT[:LEVEL]:TRIGGERED?

Description:**Indicates programmed output current (in amperes) after trigger is executed.**

Return Format: <NRf+>

Example:CURR:TRIG? returns 2.2000E+01 to indicate output current will be programmed to 22A after trigger is executed.

**B.53 [SOURCE:]FUNCTION:SEQUENCE COMMAND****FUNC:SEQ**

Syntax:Short Form: FUNC:SEQ { RUN | STOP | PAUSE }  
 Long Form: [SOURCE:]FUNCTION:SEQUENCE { RUN | STOP | PAUSE }

Description:**Causes the sequence selected by FUNC:SEQ:EDIT to run, stop or pause.** The step number is specified by FUNC:SEQ:STEP. The sequence number being edited is determined by FUNC:SEQ:EDIT command.

Argument:<RUN> causes sequence to run,  
 <STOP> causes sequence to pause. Subsequent FUNC:SEQ RUN causes sequence to start from first step.  
 <PAUSE> causes sequence to stop running, but will continue from the next step if FUNC:SEQ RUN is issued.

Example:FUNC:SEQ RUN causes the previously specified sequence to run.

**B.54 [SOURCE:]FUNCTION:SEQUENCE? QUERY****FUNC:SEQ?**

Syntax: Short Form: FUNC:SEQ?

Long Form: [SOURCE:]FUNCTION:SEQUENCE?

Description: **Indicates whether the previously specified sequence is running, stopped or paused.** Must be preceded by FUNC:SEQ:EDIT.

Return Format: RUN, STOP or PAUSE

Example: FUNC:SEQ:? returns STOP to indicate the selected sequence is stopped.

**B.55 [SOURCE:]FUNCTION:SEQUENCE:COMPLETE COMMAND****FUNC:SEQ:COMP**

Syntax: Short Form: FUNC:SEQ:COMP <NRf+>

Long Form: [SOURCE:]FUNCTION:SEQUENCE:COMPLETE <NRf+>

Description: **Used to exit sequence editing.** This command is sent when editing of a sequence is complete (see PAR. B.59 for details).

Argument: <NRf+> is a value in the range from 0 to 105% of rated current (in Amperes).

Example: FUNC:SEQ:CURRE 2.2000E+1 programs the current for the previously specified step and sequence to be 22 Amperes.

**B.56 [SOURCE:]FUNCTION:SEQUENCE:COMPLETE? QUERY****FUNC:SEQ:COMP?**

Syntax: Short Form: FUNC:SEQ:COMP?

Long Form: [SOURCE:]FUNCTION:SEQUENCE:COMPLETE?

Description: **Indicates whether sequence editing is complete or in progress**

Return Format: <DONE> Editing is complete.

<PROCESSING> Editing is in progress.

Example: FUNC:SEQ:COMP? returns PROCESSING while sequence editing is in progress, returns DONE to indicate sequence editing is complete (see PAR. B.59 for details).

**B.57 [SOURCE:]FUNCTION:SEQUENCE:CURRENT COMMAND****FUNC:SEQ:CURRE**

Syntax: Short Form: FUNC:SEQ:CURRE <NRf+>

Long Form: [SOURCE:]FUNCTION:SEQUENCE:CURRENT <NRf+>

Description: **Sets the value of current (in Amperes) for one step of a sequence.** The step number is specified by FUNC:SEQ:STEP. The sequence number being edited is determined by FUNC:SEQ:EDIT command (see PAR. B.59 for details).

Argument: <NRf+> is a value in the range from 0 to 105% of rated current (in Amperes).

Example: FUNC:SEQ:CURRE 2.2000E+1 programs the current for the previously specified step and sequence to be 22 Amperes.

**B.58 [SOURCE:]FUNCTION:SEQUENCE:CURRENT? QUERY****FUNC:SEQ:CURRE?**

Syntax: Short Form: FUNC:SEQ:CURRE?

Long Form: [SOURCE:]FUNCTION:SEQUENCE:CURRENT?

Description: **Indicates the current (in Amperes) for the previously specified step.** Must be preceded by FUNC:SEQ:STEP (see PAR. B.59 for details).

Return Format: <NRf+>

Example: FUNC:SEQ:CURRE? returns 2.2000E+1 to indicate current for the specified step is 22 Amperes.

**B.59 [SOURCE:]FUNCTION:SEQUENCE:EDIT COMMAND****FUNC:SEQ:EDIT**

Syntax: Short Form: FUNC:SEQ:EDIT <NR1>  
 Long Form: [SOURCE:]FUNCTION:SEQUENCE:EDIT <NR1>

Description: **Used to enter sequence editing mode and specify which sequence is to be edited.** Once this command is sent, Sequence Editing mode is entered. The command FUNC:SEQ:STEP then specifies which step is to be edited. The commands FUNC:SEQ:VOLT, FUNC:SEQ:CURR, FUNC:SEQ:POW, and FUNC:SEQ:TIME specify the parameters for the step. This command sequence (STEP, VOLT, CURR, POW, TIME) is repeated for each step in the sequence. Once all steps have been edited, the FUNC:SEQ:COMP command is sent to initiate processing of the edited steps. The unit proceeds to process the edited sequence. Sending the FUNC:SEQ:COMP? query returns DONE when processing is complete, or PROCESSING if not yet complete.

Argument: <NR1> is a number from 1 to 16 specifying the sequence to be edited.

Example: FUNC:SEQ:EDIT 2 starts sequence editing of sequence number 2.

**B.60 [SOURCE:]FUNCTION:SEQUENCE:EDIT? QUERY****FUNC:SEQ:EDIT?**

Syntax: Short Form: FUNC:SEQ:EDIT?  
 Long Form: [SOURCE:]FUNCTION:SEQUENCE:EDIT?

Description: **Indicates which sequence is being edited.** See PAR. B.59 for details.

Return Format: <NR1> is a number from 1 to 16 specifying the sequence being edited.

Example: FUNC:SEQ:EDIT? returns 4 to indicate sequence number 4 is being edited.

**B.61 [SOURCE:]FUNCTION:SEQUENCE:END COMMAND****FUNC:SEQ:END**

Syntax: Short Form: FUNC:SEQ:END <NR1>  
 Long Form: [SOURCE:]FUNCTION:SEQUENCE:END <NR1>

Description: **Used to set the last step of a sequence.**

Argument: <NR1> is a number from 1 to 500 specifying the last step in the sequence.

Example: FUNC:SEQ:END 6 sets step 6 as the last step of the sequence.

**B.62 [SOURCE:]FUNCTION:SEQUENCE:END? QUERY****FUNC:SEQ:END?**

Syntax: Short Form: FUNC:SEQ:END? Long Form: [SOURCE:]FUNCTION:SEQUENCE:END?

Description: **Indicates which step is the last step of a sequence.**

Return Format: <NR1> is a number from 1 to 500 specifying the last step in the sequence.

Example: FUNC:SEQ:END? returns 6 to indicate step number 4 is the last step of the sequence being edited.

**B.63 [SOURCE:]FUNCTION:SEQUENCE:LIST COMMAND****FUNC:SEQ:LIST**

Syntax: Short Form: FUNC:SEQ:LIST <seq1> <seq2> ... <seq16>  
 Long Form: [SOURCE:]FUNCTION:SEQUENCE:LIST <seq1> <seq2> ... <seq16>

Description: **Determines the order of execution for multiple sequences.**

Argument: <seq1> ... <seq16> = <NR1>  
 <NR1> can be a number from 1 to 16 specifying the order of sequence execution.

Example: FUNC:SEQ:LIST 2 5 1 means that sequence 2 is executed first, then sequence 5, then sequence 1.

**B.64 [SOURCE:]FUNCTION:SEQUENCE:LIST? QUERY** **FUNC:SEQ:LIST?**  
 Syntax:Short Form: FUNC:SEQ:LIST? Long Form: [SOURCE:]FUNCTION:SEQUENCE:LIST?  
 Description:**Indicates the order of execution for multiple sequences.**  
 Return Format:<seq1> <seq2> ... <seq16>  
 where <seq1> thru <seq16 > = <NR1> representing sequence numbers  
 Example:FUNC:SEQ:LIST? returns 6 3 2 indicating sequence 6 is executed first, then sequence 3, then sequence 2.

**B.65 [SOURCE:]FUNCTION:SEQUENCE:LOOP COMMAND** **FUNC:SEQ:LOOP**  
 Syntax:Short Form: FUNC:SEQ:LOOP <NR1>  
 Long Form: [SOURCE:]FUNCTION:SEQUENCE:LOOP <NR1>  
 Description:**Determines how many times the sequence is to be repeated.**  
 Argument: <NR1> is a number from 1 to 999999 specifying how many times the sequence is to be repeated.  
 Example:FUNC:SEQ:LOOP 25 means that the sequence is to be repeated 25 times.

**B.66 [SOURCE:]FUNCTION:SEQUENCE:LOOP? QUERY** **FUNC:SEQ:LOOP?**  
 Syntax:Short Form: FUNC:SEQ:LOOP? Long Form: [SOURCE:]FUNCTION:SEQUENCE:LOOP?  
 Description:**Indicates how many times the sequence is to be repeated.**  
 Return Format: <NR1> is a number from 1 to 999999 specifying how many times the sequence is to be repeated.  
 Example:FUNC:SEQ:LOOP? returns 25 to indicate the sequence will repeat 25 times.

**B.67 [SOURCE:]FUNCTION:SEQUENCE:NOW? QUERY** **FUNC:SEQ:NOW?**  
 Syntax:Short Form: FUNC:SEQ:NOW? Long Form: [SOURCE:]FUNCTION:SEQUENCE:NOW?  
 Description:**Indicates which step is the last step of a sequence.**  
 Return Format:<sequence>,<step>,<loop>  
 <sequence> This is a number indicating the sequence being edited.  
 <step> This is a number indicating the number of steps in the sequence  
 <loop> This is a number indicating how many times the sequence is to be repeated.  
 Example:FUNC:SEQ:NOW? returns 6,4,12 to indicate sequence number 6 has 4 steps to be repeated 12 times

**B.68 [SOURCE:]FUNCTION:SEQUENCE:POWER COMMAND<sup>(†)</sup>** **FUNC:SEQ:POW**  
 Syntax:Short Form: FUNC:SEQ:POW <NRf+>  
 Long Form: [SOURCE:]FUNCTION:SEQUENCE:POWER <NRf+>  
 Description:**Sets the value of power (in Watts) for one step of a sequence.** The step number is specified by FUNC:SEQ:STEP. The sequence number being edited is determined by FUNC:SEQ:EDIT command.  
 Argument: <NRf+> is a value in the range from 0 to 102% of rated power (in Watts).  
 Example:FUNC:SEQ:POW 2.2000E+3 programs the current for the previously specified step and sequence to be 2200 Watts.

**B.69 [SOURCE:]FUNCTION:SEQUENCE:POWER? QUERY<sup>(†)</sup>** **FUNC:SEQ:POW?**  
 Syntax:Short Form: FUNC:SEQ:POW? Long Form: [SOURCE:]FUNCTION:SEQUENCE:POWER?  
 Description:**Indicates the power (in Watts) for the previously specified step.** Must be preceded by FUNC:SEQ:STEP  
 Return Format: <NRf+>  
 Example:FUNC:SEQ:POW? returns 2.2000E+3 to indicate power for the specified step is 2200 Watts.



**B.70 [SOURCE:]FUNCTION:SEQUENCE:STEP COMMAND****FUNC:SEQ:STEP**

Syntax:Short Form: FUNC:SEQ:STEP <NR1>

Long Form: [SOURCE:]FUNCTION:SEQUENCE:STEP <NR1>

Description:**Used to specify which step is to be edited.** See PAR. B.59 for sequence editing details.

Argument: <NR1> is a number from 1 to 500 specifying the step to be edited.

Example:FUNC:SEQ:STEP 5 sets step 5 as the step to be edited by subsequent commands.

**B.71 [SOURCE:]FUNCTION:SEQUENCE:STEP? QUERY****FUNC:SEQ:STEP?**

Syntax:Short Form: FUNC:SEQ:STEPSTEP?

Long Form: [SOURCE:]FUNCTION:SEQUENCE:STEP?

Description:**Indicates which step is being edited.**

Return Format: <NR1> is a number from 1 to 500 specifying the step to be edited.

Example:FUNC:SEQ:STEP? returns 5 to indicate step number 5 is the step to be edited by subsequent commands.

**B.72 [SOURCE:]FUNCTION:SEQUENCE:TIME COMMAND****FUNC:SEQ:TIME**

Syntax:Short Form: FUNC:SEQ:TIME <NRf+>

Long Form: [SOURCE:]FUNCTION:SEQUENCE:TIME <NRf+>

Description:**Sets the value of time (in Seconds) for one step of a sequence. The time determines the time duration of the step.** The step number is specified by FUNC:SEQ:STEP. The sequence number being edited is determined by FUNC:SEQ:EDIT command.

Argument: <NRf+> is a value in the range from 0.001 to 99999.999 seconds (in Seconds).

Example:FUNC:SEQ:TIME 4.0000E+0 programs the time for the previously specified step and sequence to be 4 Seconds.

**B.73 [SOURCE:]FUNCTION:SEQUENCE:TIME? QUERY****FUNC:SEQ:TIME?**

Syntax:Short Form: FUNC:SEQ:TIME?

Long Form: [SOURCE:]FUNCTION:SEQUENCE:TIME?

Description:**Indicates the time (in Seconds) for the previously specified step.** Must be preceded by FUNC:SEQ:TIME

Return Format: <NRf+>

Example:FUNC:SEQ:TIME? returns 4.0000E+0 to indicate the time programmed for the specified step is 4 Seconds.

**B.74 [SOURCE:]FUNCTION:SEQUENCE:VOLTAGE COMMAND****FUNC:SEQ:VOLT**

Syntax:Short Form: FUNC:SEQ:VOLT <NRf+>

Long Form: [SOURCE:]FUNCTION:SEQUENCE:VOLTAGE <NRf+>

Description:**Sets the value of voltage (in Volts) for one step of a sequence.** The step number is specified by FUNC:SEQ:STEP. The sequence number being edited is determined by FUNC:SEQ:EDIT command.

Argument: <NRf+> is a value in the range from 0 to 105% of rated voltage (in Volts).

Example:FUNC:SEQ:VOLT 2.2000E+2 programs the current for the previously specified step and sequence to be 220 Volts.

**B.75 [SOURCE:]FUNCTION:SEQUENCE:VOLTAGE? QUERY****FUNC:SEQ:VOLT?**

Syntax: Short Form: FUNC:SEQ:VOLT?

Long Form: [SOURCE:]FUNCTION:SEQUENCE:VOLTAGE?

Description:**Indicates the current (in Amperes) for the previously specified step.** Must be preceded by FUNC:SEQ:STEP

Return Format: <NRf+>

Example:FUNC:SEQ:VOLT? returns 2.2000E+2 to indicate current for the specified step is 220 Volts.

## MODE

### B.76 [SOURCE:]MODE COMMAND

Syntax: Short Form: MODE {SIMP | COMP | SEQU | INSE | SASC | SAST}  
Long Form: [SOURCE:]MODE {SIMPlE | COMPlEtE | SEQUenCe | INSErtion | SASCurVe | SASTable}

Description: **Sets the operating mode to Simple, Complete, Sequence, Insertion, SAS curve or SAS table.**

Argument:: <SIMPlE> Sets Simple mode. See PAR. 3.4.2.1 for details.  
<COMPlEtE> Sets Complete mode. See PAR. 3.4.2.2 for details.  
<SEQUenCe> Sets Sequence mode. See PAR. 3.4.2.3 for details.  
<INSErtion> Sets Insertion mode. See PAR. 3.4.2.4 for details.  
<SASCurVe> NOT APPLICABLE. Sets SAS Curve mode. See PAR. 3.4.3 for details.  
<SASTable> NOT APPLICABLE. Sets SAS Table mode. See PAR. 3.4.3 for details.

Example: SYST:MODE COMP sets the operating mode to Complete.

## MODE?

### B.77 [SOURCE:]MODE? QUERY

Syntax: Short Form: MODE? Long Form: [SOURCE:]MODE?

Description: **Indicates the operating mode**

Return Format: <SIMP> for Simple mode. See PAR. 3.4.2.1 for details.  
<COMP> for Complete mode. See PAR. 3.4.2.2 for details.  
<SEQU> for Sequence mode. See PAR. 3.4.2.3 for details.  
<INSE> for Insertion mode. See PAR. 3.4.2.4 for details.  
<SASC> for SAS Curve mode NOT APPLICABLE. See PAR. 3.4.3 for details.  
<SAST> for SAS Table mode NOT APPLICABLE. See PAR. 3.4.3 for details.

Example: MODE? returns INSE to indicate the operating mode is Insertion,

## POW

### B.78 [SOURCE:]POW[:LEVel][:IMMediate][:AMPLitude] COMMAND<sup>(†)</sup>

Syntax: Short Form: POW <NRf+> { MIN | MAX }  
Long Form: [SOURCE:]POW[:LEVel][:IMMediate][:AMPLitude] <NRf+> { MIN | MAX }

Description: **Sets the output power value.** Maximum output power is rated power; minimum power is zero.

Argument: <NRf+> is a value in the range from 0 to rated power of unit. Rated voltage and current are defined by model (e.g., for KLN 650-23E, rated power is 5000W.).  
<MIN> is 0 watts  
<MAX> is 102% of rated power of unit

Example: For KLN 650-23E POW 4.5000e+03 sets output power value to 4500W.

## POW?

### B.79 [SOURCE:]POW[:LEVel][:IMMediate][:AMPLitude]? QUERY<sup>(†)</sup>

Syntax: Short Form: POW?  
Long Form: [SOURCE:]POW[:LEVel][:IMMediate][:AMPLitude]?

Description: **Indicates programmed output power (in Watts).**

Return Format: <NRf+>

Example: POW? returns 4.5000E+03 to indicate output power is programmed to 4500W.

### B.80 [SOURCE:]POW:PROT:LEVel COMMAND

## POW:PROT:LEV

Syntax: Short Form: POW:PROT:LEV <NRf+>  
Long Form: [SOURCE:]POW:PROT:LEVel <NRf+>

Argument: <NRf+> is a value in the range from 10% to 110% of rated current.  
MAX is 110% of rated current of unit

Description: **Sets the overpower protection (OPP) value (in Watts).** OPP values set using this command are in effect once the unit is returned to local operation. Maximum value is 100% of rated power. MIN sets OPP to be 10% of rated power. \*RST sets POW:PROT:LEV to maximum value.

Example: POW:PROT:LEV MAX sets the overpower protection level to 10,000W. This is the maximum value if the unit is a 650V, 46A model. POW:PROT:LEV MIN sets the overpower protection level to be 4.6A if the unit is a 650V, 46A model.

**B.81 [SOURCE:]POWER:PROTECTION:LEVEL? QUERY****POW:PROT:LEV?**

Syntax: Short Form: POW:PROT:LEV?  
 Long Form: [SOURCE:]POWER:PROTECTION:LEVEL?

Description: **Indicates programmed overpower protection (OPP) level for output power (in Watts).**

Return Format: <NRf+>

Example: POW:PROT:LEV? returns 1E+04 to indicate overpower protection level is programmed to 10,000W.

**B.82 [SOURCE:]POWER:SLEW:RATE COMMAND(†)****POW:SLEW:RATE**

Syntax: Short Form: POW:SLEW:RATE <NR1> {MIN | MAX}  
 Long Form: [SOURCE:]POWER:SLEW:RATE <NR1> {MIN | MAX}

Argument: <NRf+> is a value with W/mS as unit, the setting range varied by model.

MIN sets the slew rate to 0.1% of rated power/ms.

MAX sets the slew rate to 10% of rated power/ms.

Description: This command sets the slew rate (the rate at which power changes from the existing value to the new programmed value for all programmed changes of output power. MIN sets the slew rate to 0.1% of rated power/ms. MAX sets the slew rate to 10% of rated power/ms. Default is MAX.

Example: POW:SLEW:RATE 1050 sets the slew rate to 1050W/mS, For KLN 80-180E e.g., POW:SLEW:RATE MIN sets the slew rate to 500W/ms. POW:SLEW:RATE MAX sets the slew rate to 5000W/ms.

**B.83 [SOURCE:]POWER:SLEW:RATE? QUERY(†)****POW:SLEW:RATE?**

Syntax: Short Form: POW:SLEW:RATE? Long Form: [SOURCE:]POWER:SLEW:RATE?

Description: **Indicates state of overcurrent protection (OCP)**

Return Format: <NR1> is the power slew rate setting (W/mS)

Example: POW:SLEW:RATE? returns 10 to indicate current slew rate is 10W/mS.

**B.84 [SOURCE:]RESISTANCE COMMAND(†)****RES**

Syntax: Short Form: RES <NRf+> { MIN | MAX }  
 Long Form: [SOURCE:]RESISTANCE <NRf+> { MIN | MAX }

Description: **Sets the simulated internal resistance, allowing the unit to simulate a battery.** The range is determined by model (see Table 3-4). Maximum resistance is the highest value listed in Table 3-4 for the model in question; minimum resistance is zero.

Argument: <NRf+> is a value (Ohms) within the range listed in Table 3-4 for a particular model.

<MIN> is 0

<MAX> is the highest value listed in Table 3-4 for a particular model.

Example: RES 4.5000e+0 sets the internal resistance to 4.5 Ohms

**B.85 [SOURCE:]RESISTANCE? QUERY(†)****RES?**

Syntax: Short Form: RES?  
 Long Form: [SOURCE:]RESISTANCE?

Description: **Indicates simulated internal resistance (in Ohms).**

Return Format: <NRf+>

Example: RES? returns 4.5000E+0 to indicate internal resistance is programmed to 4.5 Ohms.

## TIME

### B.86 [SOURCE:]TIME COMMAND

Syntax:Short Form: TIME <NRf+> { MIN | MAX }  
Long Form: [SOURCE:]TIME <NRf+> { MIN | MAX }

Description:**Sets the output ON time.** When set to 0, the values of VOLT, CURR and POW commands are present at the output continuously. When set to a value other than 0, the output is ON only for the programmed interval.

Argument: <NRf+> is a value (seconds) from 0 to 99999.9  
<MIN> is 0 (output on continuously)  
<MAX> is 99999.9 seconds

Example:TIME 30 sets the output to be ON, and the values programmed by VOLT, CURR and POW to be present at the output for 30 seconds.

## TIME?

### B.87 [SOURCE:]TIME? QUERY

Syntax:Short Form: TIME?  
Long Form: [SOURCE:]TIME?

Description:**Indicates programmed value for TIME (output on time).**

Return Format: <NRf+> is a value (Seconds) from 0 to 99999.9

Example:TIME? returns 3.0000E+1 to indicate output on time is programmed to 30 seconds.

## VOLT

### B.88 [SOURCE:]VOLTage[:LEVel][:IMMediate][:AMPLitude] COMMAND

Syntax:Short Form: VOLT <NRf+> { MIN | MAX }  
Long Form: [SOURCE:]VOLTage[:LEVel][:IMMediate][:AMPLitude] <NRf+> { MIN | MAX }

Description:**Sets the output voltage value.** Maximum output voltage is rated voltage; minimum voltage is zero.

Argument: <NRf+> is a value in the range from 0 to rated voltage of unit. Rated voltage and voltage are defined by model (e.g., for KLN 650-23E, rated voltage is 650V, rated current is 23A).  
<MIN> is 0  
<MAX> is 105% of rated voltage of unit

Example:For KLN 650-23E VOLT 60 sets output voltage value to 60V, VOLT MAX sets output voltage value to 682.5V

## VOLT?

### B.89 [SOURCE:]VOLTage[:LEVel][:IMMediate][:AMPLitude]? QUERY

Syntax:Short Form: VOLT?  
Long Form: [SOURCE:]VOLTage[:LEVel][:IMMediate][:AMPLitude]?

Description:**Indicates programmed output voltage (in Volts).**

Return Format: <NRf+>

Example:VOLT? returns 6.0000E+01 to indicate output voltage is programmed to 60V.

## VOLT:MODE

### B.90 [SOURCE:]VOLTage:MODE COMMAND

Syntax:Short Form: VOLT:MODE { FIX | STEP }  
Long Form: [SOURCE:]VOLTage:MODE { FIX | STEP }

Description:**Determines whether output voltage is set using VOLT command (FIX) or VOLT:TRIG command (STEP).**

Argument:<FIX> output voltage can only be set using VOLT command  
<STEP> output voltage can only be set using VOLT:TRIG command

Example:VOLT:MODE FIX requires that output voltage be set using VOLT command.

**B.91 [SOURCE:]VOLTage:MODE? QUERY****VOLT:MODE?**

Syntax: Short Form: VOLT:MODE?  
 Long Form: [SOURCE:]VOLTage:MODE?

Description: **Indicates how voltage is to be programmed.** Either VOLT commands (FIX) or VOLT:TRIG commands (STEP) determined the value of output voltage.

Return Format: either FIX (use VOLT command to set output voltage) or STEP (execute trigger to set voltage to value determined by VOLT:TRIG command).

Example: VOLT:MODE? returns FIX indicating VOLT must be used to set output voltage.

**B.92 [SOURCE:]VOLTage:PROTection[:LEVel] COMMAND****VOLT:PROT**

Syntax: Short Form: VOLT:PROT:[LEV] <NRf+> { MAX }  
 Long Form: [SOURCE:]VOLTage:PROTection[:LEVel] <NRf+> { MAX }

Argument: <NRf+> is a value in the range from 0% to 110% of rated voltage.  
 MAX is 110% of rated voltage of unit

Description: **Sets the overvoltage protection (OCP) value (in Volts).** OVP values set using this command stay in effect once the unit is returned to local operation. Maximum value is 110% of rated voltage. \*RST sets SOUR:VOLT:PROT:LEV to maximum value.

Example: If the unit is a 650V, 23A model, SOUR:VOLT:PROT MAX sets the overvoltage protection level to 715V, the maximum value.

**B.93 [SOURCE:]VOLTage:PROTection[:LEVel]? QUERY****VOLT:PROT?**

Syntax: Short Form: VOLT:PROT:LEV?  
 Long Form: [SOURCE:]VOLTage:PROTection[:LEVel]?

Description: **Indicates programmed overvoltage protection (OVP) level for output voltage (in Volts).**

Return Format: <NRf+>

Example: VOLT:PROT? returns 5.65000E+02 to indicate overvoltage protection level is programmed to 565V.

**B.94 [SOURCE:]VOLTage:SLEW:RATE COMMAND****VOLT:SLEW:RATE**

Syntax: Short Form: VOLT:SLEW:RATE <NR1> { MIN | MAX }  
 Long Form: [SOURCE:]VOLTage:SLEW:RATE <NR1> { MIN | MAX }

Argument: <NRf+> is a value (V/mS), the setting range varied by model.  
 MIN sets the slew rate to 0.1% of rated voltage/ms.  
 MAX sets the slew rate to rated voltage/ms.

Description: This command sets the slew rate (the rate at which voltage changes from the existing value to the new programmed value) for all programmed changes of output voltage. MIN sets the slew rate to 0.1% of rated voltage/ms. MAX sets the slew rate to rated voltage/ms. Default is MAX.

Example: VOLT:SLEW:RATE 50 sets the slew rate to 50V/mS. For KLN 80-180E e.g., VOLT:SLEW:RATE MIN sets the slew rate to 0.008V/ms, VOLT:SLEW:RATE MAX sets the slew rate to 80V/ms.

**B.95 [SOURCE:]VOLTage:SLEW:RATE? QUERY****VOLT:SLEW:RATE?**

Syntax: Short Form: VOLT:SLEW:RATE? Long Form: [SOURCE:]VOLTage:SLEW:RATE?

Description: **Indicates state of overvoltage protection (OCP)**

Return Format: <NR1> is the voltage slew rate setting (A/mS)

Example: VOLT:SLEW:RATE? returns 10 to indicate voltage slew rate is 10A/mS.

**B.96 [SOURce:]VOLTage[:LEVel]:TRIGgerred COMMAND****VOLT:TRIG**

Syntax: Short Form: VOLT:TRIG <NRf+> { MIN | MAX }

Long Form: [SOURce:]VOLTage[:LEVel]:TRIGgerred <NRf+> { MIN | MAX }

Description: **Sets the output voltage value after trigger has been executed.** See PAR. B.36 for details. Maximum output voltage is 105% of rated voltage; minimum voltage is zero.

Argument: <NRf+> is a value in the range from 0 to rated voltage of unit.

<MIN> is 0

<MAX> is 105% of rated voltage of unit.

Example: VOLT:TRIG 220 sets output voltage value to 220V after trigger executed, For KLN 650-23E VOLT:TRIG MAX sets output voltage value to 682.5V after trigger executed.

**B.97 [SOURce:]VOLTage[:LEVel]:TRIGgerred? QUERY****VOLT:TRIG?**

Syntax: Short Form: VOLT:TRIG?

Long Form: [SOURce:]VOLTage[:LEVel]:TRIGgerred?

Description: **Indicates programmed output voltage (in Volts) after trigger is executed.**

Return Format: <NRf+>

Example: VOLT:TRIG? returns 6.3000E+02 to indicate output voltage will be programmed to 630V after trigger is executed.

**B.98 STATus:OPERation:CONDition? QUERY****STAT:OPER:COND?**

Syntax: Short Form: STAT:OPER:COND?

Long Form: STATus:OPERation:CONDition?

Description: **Returns the value of the Operation Condition Register (see Table B-2).** The Operation Condition Register contains unlatched real-time information about the operating conditions of the power supply. Bit set to 1 = function enabled (active, true); bit reset to 0 = function disabled (inactive, false).

Return Format: <NR1> is a value in the range from 0 to 127 (1 + 2 + 4 + 8 + 16 + 32 + 64)

**TABLE B-2. OPERATION CONDITION REGISTER, OPERATION ENABLE REGISTER, AND OPERATION EVENT REGISTER BITS**

CONDITION	NU	SEQU	RAMP	WTG	NU	OFF	CC	CV
BIT	7-15	6	5	4	3	2	1	0
VALUE	128-32,768	64	32	16	8	4	2	1

CV - OUTPUT SET TO CONSTANT VOLTAGE MODE.  
 CC - OUTPUT SET TO CONSTANT CURRENT MODE.  
 CV - OUTPUT SET TO OFF.  
 NU - NOT USED.  
 WTG - TRANSIENT SYSTEM WAITING FOR TRIGGER.  
 RAMP - OUTPUT RAMP (UP OR DOWN) EXECUTING.  
 SEQU - SEQUENCE EXECUTING.

**B.99 STATus:OPERation:ENABle COMMAND****STAT:OPER:ENAB**

Syntax: Short Form: STAT:OPER:ENAB <NR1>

Long Form: STATus:OPERation:ENABle <NR1>

Argument: <NR1> is a value in the range from 0 to 127 (1 + 2 + 4 + 8 + 16 + 32 + 64)

Description: **Sets Operation Enable Register.** The Operation Enable Register is a mask for enabling specific bits in the Operation Event Register which will cause the operation summary bit (bit 7) of the Status Byte register to be set. Bit set to 1 = function enabled (active, true); bit reset to 0 = function disabled (inactive, false). The operation summary bit is the logical OR of all the enabled bits in the Operation Event register.

**B.100 STATus:OPERation:ENABle? QUERY****STAT:OPER:ENAB?**

Syntax: Short Form: STAT:OPER:ENAB?

Long Form: STATus:OPERation:ENABle?

Return Format: <NR1> is a value in the range from 0 to 127 (1 + 2 + 4 + 8 + 16 + 32 + 64)

Description: **Reads Operation Enable Register (see Table B-2).** Returns value of Operation Enable Register bits. Bit set to 1 = function enabled (active, true); bit reset to 0 = function disabled (inactive, false).

**B.101 STATus:OPERation:EVENT? QUERY****STAT:OPER:EVEN?**

Syntax: Short Form: STAT:OPER:EVEN? Long Form: STATus:OPERation:EVENT?

Return Format: <NR1> is a value in the range from 0 to 127 (1 +2 + 4 + 8 + 16 + 32 + 64)

Description: **Reads Status Operation Event Register (see Table B-2).** Queries the event register for the Operation Status group. This is a read-only register, which stores (latches) all events that are passed by the Operation NTR and PTR filters. Reading the Operation Status Event register clears it.

**B.102 STATus:OPERation:NTRansition COMMAND****STAT:OPER:NTR**

Syntax: Short Form: STAT:OPER:NTR <NR1>  
Long Form: STATus:OPERation:NTRansition <NR1>

Argument: <NR1> is a value in the range from 0 to 127 (1 +2 + 4 + 8 + 16 + 32 + 64)

Description: **Sets Operation NTR Register.** The Operation NTR (Negative Transition) and PTR (Positive Transition) registers serve as polarity filters between the Operation Enable and Operation Event registers to cause the following actions:

- When a bit in the Operation NTR register is set to 1, then a 1-to-0 transition of the corresponding bit in the Operation Condition register causes that bit in the Operation Event register to be set.
- If the same bits in both Operation NTR and PTR registers are set to 1, then any transition of that bit at the Operation Condition register sets the corresponding bit in the Operation Event register.
- If the same bits in both Operation NTR and PTR registers are set to 0, then no transition of that bit at the Operation Condition register can set the corresponding bit in the Operation Event register

**B.103 STATus:OPERation:NTRansition? QUERY****STAT:OPER:NTR?**

Syntax: Short Form: STAT:OPER:NTR? Long Form: STATus:OPERation:NTRansition?

Return Format: <NR1> is a value in the range from 0 to 127 (1 +2 + 4 + 8 + 16 + 32 + 64)

Description: **Reads Operation NTR Register (see Table B-2).** Returns value of NTR Operation Register bits. Bit set to 1 = function enabled (active, true); bit reset to 0 = function disabled (inactive, false).

**B.104 STATus:OPERation:PTRansition COMMAND****STAT:OPER:PTR**

Syntax: Short Form: STAT:OPER:PTR <NR1>  
Long Form: STATus:OPERation:PTRansition <NR1>

Argument: <NR1> is a value in the range from 0 to 127 (1 +2 + 4 + 8 + 16 + 32 + 64)

Description: **Sets Operation NTR Register.** The Operation NTR (Negative Transition) and PTR (Positive Transition) registers serve as polarity filters between the Operation Enable and Operation Event registers to cause the following actions:

- When a bit in the Operation PTR register is set to 1, then a 0-to-1 transition of the corresponding bit in the Operation Condition register causes that bit in the Operation Event register to be set.
- If the same bits in both Operation NTR and PTR registers are set to 1, then any transition of that bit at the Operation Condition register sets the corresponding bit in the Operation Event register.
- If the same bits in both Operation NTR and PTR registers are set to 0, then no transition of that bit at the Operation Condition register can set the corresponding bit in the Operation Event register

**B.105 STATus:OPERation:PTRansition? QUERY****STAT:OPER:PTR?**

Syntax: Short Form: STAT:OPER:PTR? Long Form: STATus:OPERation:PTRansition?

Return Format: <NR1> is a value in the range from 0 to 127 (1 +2 + 4 + 8 + 16 + 32 + 64)

Description: **Reads Operation PTR Register (see Table B-2).** Returns value of PTR Operation Register bits. Bit set to 1 = function enabled (active, true); bit reset to 0 = function disabled (inactive, false).

**B.106 STATus:QUEStionable:CONDition? QUERY****STAT:QUES:COND?**

Syntax: Short Form: STAT:QUES:COND?

Long Form: STATus:QUEStionable:CONDition?

Description: **Returns the value of the Questionable Condition Register (see Table B-2).** The Questionable Condition Register contains unlatched real-time information about the questionable conditions of the power supply. Bit set to 1 = function enabled (active, true); bit reset to 0 = function disabled (inactive, false). This is the only register that holds the real-time (unlatched) status of the a-c **SOURCE**.

Return Format: &lt;NR1&gt; is a value in the range from 0 to 127 (1 + 2 + 4 + 8 + 16 + 32 + 64)

**TABLE B-3. QUESTIONABLE CONDITION REGISTER, QUESTIONABLE ENABLE REGISTER, AND QUESTIONABLE EVENT REGISTER BITS**

CONDITION	NU	SHF	NU	MSP	OT	CP	PF	OC	OV
BIT	10-15	9	6-8	5	4	3	2	1	0
VALUE	1024-32,768	512	64-256	32	16	8	4	2	1

OV - OVERVOLTAGE PROTECTION TRIPPED.  
 OC - OVERCURRENT PROTECTION TRIPPED.  
 PF - OUTPUT OFF DUE TO POWER FAILURE.  
 CP - OUTPUT IN CONSTANT POWER MODE.  
 OT - OVERTEMPERATURE PROTECTION TRIPPED.  
 MSP - OUTPUT DISABLED BY MASTER/SLAVE PROTECTION.  
 NU - NOT USED.

**B.107 STATus:QUEStionable:ENABLE COMMAND****STAT:QUES:ENAB**

Syntax: Short Form: STAT:QUES:ENAB &lt;NR1&gt;

Long Form: STATus:QUEStionable:ENABLE &lt;NR1&gt;

Argument: &lt;NR1&gt; is a value in the range from 0 to 575 (1 + 2 + 4 + 8 + 16 + 32 + 512)

Description: **Sets Questionable Enable Register.** The Questionable Enable Register is a mask for enabling specific bits in the Questionable Event Register which will cause the questionable summary bit (bit 7) of the Status Byte register to be set. Bit set to 1 = function enabled (active, true); bit reset to 0 = function disabled (inactive, false). The questionable summary bit is the logical OR of all the enabled bits in the Questionable Event register. STATus:PRESet clears all bits in the enable register.

**B.108 STATus:QUEStionable:ENABLE? QUERY****STAT:QUES:ENAB?**

Syntax: Short Form: STAT:QUES:ENAB?

Long Form: STATus:QUEStionable:ENABLE?

Return Format: &lt;NR1&gt; is a value in the range from 0 to 575 (1 + 2 + 4 + 8 + 16 + 32 + 512)

Description: **Reads Questionable Enable Register (see Table B-2).** Returns value of Questionable Enable Register bits. Bit set to 1 = function enabled (active, true); bit reset to 0 = function disabled (inactive, false).

**B.109 STATus:QUEStionable:EVENT? QUERY****STAT:QUES:EVENT?**

Syntax: Short Form: STAT:QUES:EVENT?

Long Form: STATus:QUEStionable:EVENT?

Return Format: &lt;NR1&gt; is a value in the range from 0 to 575 (1 + 2 + 4 + 8 + 16 + 32 + 512)

Description: **Reads Status Questionable Event Register (see Table B-2).** Queries the event register for the Questionable Status group. This is a read-only register, which stores (latches) all events that are passed by the Questionable NTR and PTR filters. Reading the Questionable Status Event register clears it.



### B.110 STATus:QUEStionable:NTRansition COMMAND

## STAT:QUES:NTR

Syntax: Short Form: STAT:QUES:NTR <NR1>  
Long Form: STATus:QUEStionable:NTRansition <NR1>

Argument: <NR1> is a value in the range from 0 to 575 (1 +2 + 4 + 8 + 16 + 32 + 512)

Description: **Sets Questionable NTR Register.** The Questionable NTR (Negative Transition) and PTR (Positive Transition) registers serve as polarity filters between the Questionable Enable and Questionable Event registers to cause the following actions:

- When a bit in the Questionable NTR register is set to 1, then a 1-to-0 transition of the corresponding bit in the Questionable Condition register causes that bit in the Questionable Event register to be set.
- If the same bits in both Questionable NTR and PTR registers are set to 1, then any transition of that bit at the Questionable Condition register sets the corresponding bit in the Questionable Event register.
- If the same bits in both Questionable NTR and PTR registers are set to 0, then no transition of that bit at the Questionable Condition register can set the corresponding bit in the Questionable Event register

### B.111 STATus:QUEStionable:NTRansition? QUERY

## STAT:QUES:NTR?

Syntax: Short Form: STAT:QUES:NTR? Long Form: STATus:QUEStionable:NTRansition?

Return Format: <NR1> is a value in the range from 0 to 575 (1 +2 + 4 + 8 + 16 + 32 + 512)

Description: **Reads Questionable NTR Register (see Table B-2).** Returns value of NTR Questionable Register bits. Bit set to 1 = function enabled (active, true); bit reset to 0 = function disabled (inactive, false).

### B.112 STATus:QUEStionable:PTRansition COMMAND

## STAT:QUES:PTR

Syntax: Short Form: STAT:QUES:PTR <NR1>  
Long Form: STATus:QUEStionable:PTRansition <NR1>

Argument: <NR1> is a value in the range from 0 to 575 (1 +2 + 4 + 8 + 16 + 32 + 512)

Description: **Sets Questionable NTR Register.** The Questionable NTR (Negative Transition) and PTR (Positive Transition) registers serve as polarity filters between the Questionable Enable and Questionable Event registers to cause the following actions:

- When a bit in the Questionable PTR register is set to 1, then a 0-to-1 transition of the corresponding bit in the Questionable Condition register causes that bit in the Questionable Event register to be set.
- If the same bits in both Questionable NTR and PTR registers are set to 1, then any transition of that bit at the Questionable Condition register sets the corresponding bit in the Questionable Event register.
- If the same bits in both Questionable NTR and PTR registers are set to 0, then no transition of that bit at the Questionable Condition register can set the corresponding bit in the Questionable Event register

### B.113 STATus:QUEStionable:PTRansition? QUERY

## STAT:QUES:PTR?

Syntax: Short Form: STAT:QUES:PTR? Long Form: STATus:QUEStionable:PTRansition?

Return Format: <NR1> is a value in the range from 0 to 575 (1 +2 + 4 + 8 + 16 + 32 + 512)

Description: **Reads Questionable PTR Register (see Table B-2).** Returns value of PTR Questionable Register bits. Bit set to 1 = function enabled (active, true); bit reset to 0 = function disabled (inactive, false).

### B.114 SYSTem:BEEP COMMAND

## SYST:BEEP

Syntax: Short Form: SYST:BEEP { ON | OFF | 1 | 0 }  
Long Form: SYSTem:BEEP { ON | OFF | 1 | 0 }

Description: **Sets the audible beep each time a front panel key or encoder is pressed.**

Argument: <ON> or 1 enables audible beep  
<OFF> or 0 disables audible beep

Example: SYSTem:BEEP 1 turns on the audible beep.

### B.115 SYSTem:BEEP? QUERY

## SYST:BEEP?

Syntax: Short Form: SYST:BEEP? Long Form: SYSTem:BEEP?

Description: **Indicates whether audible beep is on or off.** Returns 1 to indicate the beep is on, 0 to indicate beep is off.

Return Format: { 1 | 0 }

Example: SYSTem:BEEP? returns 1 (audible beep is enabled).

### B.116 SYSTem:BUZZer COMMAND

## SYST:BUZZ

Syntax: Short Form: SYST:BUZZ { ON | OFF | 1 | 0 }  
Long Form: SYSTem:BUZZer { ON | OFF | 1 | 0 }

Description: **Sets the audible buzzer to sound when an alarm occurs.**

Argument: <ON> or 1 enables alarm buzzer  
<OFF> or 0 disables alarm buzzer

Example: SYSTem:BUZZ 1 turns on the alarm buzzer.

### B.117 SYSTem:BUZZer? QUERY

## SYST:BUZZ?

Syntax: Short Form: SYST:BUZZ? Long Form: SYSTem:BUZZer?

Description: **Indicates whether alarm buzzer is on or off.** Returns 1 to indicate the buzzer is on, 0 to indicate buzzer is off.

Return Format: { 1 | 0 }

Example: SYST:BUZZ? returns 1 (alarm buzzer is enabled).

### B.118 SYSTem:COMMunicate:RLSTate COMMAND

## SYST:COMM:RLST

Syntax: Short Form: SYST:COMM:RLST { LOC | REM | RWL }  
Long Form: SYSTem:COMMunicate:RLSTate { LOC | REM | RWL }

Description: **Sets the control mode: either Local, Remote, or Remote with Lockout.**

Argument: <LOC> sets Local Mode.  
<REM> sets Remote Mode.  
<RWL> sets Remote Mode with front panel controls disabled.

Example: SYST:COMM:RLST sets remote mode with front panel controls disabled.

### B.119 SYSTem:COMMunicate:TCP:CONTRol? QUERY

## SYST:COMM:TCP:CONT?

Syntax: Short Form: SYST:COMM:TCP:CONT?  
Long Form: SYSTem:COMMunicate:TCP:CONTRol?

Description: **Queries the SCPI-RAW port.**

Return Format: <NR1>

Example: SYST:COMM:TCP:CONT? returns 25.

# SYST:DATE

## B.120 SYSTem:DATE COMMAND

Syntax: Short Form: SYST:DATE "YYYY/MM/DD"  
Long Form: SYSTem:DATE "YYYY/MM/DD"

Description: **Sets the current date to be displayed on the front panel touchscreen display.**

Argument: <YYYY> sets year.  
<MM> sets month.  
<DD> sets day.

Example: SYST:DATE 2016/12/15 sets the date to December 15, 2016.

# SYST:DATE?

## B.121 SYSTem:DATE? QUERY

Syntax: Short Form: SYST:DATE? Long Form: SYSTem:DATE?

Description: **Indicates the date to be displayed on the from panel touchscreen display.**

Return Format: YYYY/MM/DD where <YYYY> is the year, MM is the month. and DD is the day.

Example: SYST:DATE? returns 2016/12/15 to indicate the date is December 15, 2016.

# SYST:ERR?

## B.122 SYSTem:ERRor? QUERY

Syntax: Short Form: SYST:ERR? Long Form: SYSTem:ERRor?

Description: **Returns error codes and messages.**

Return Format: <string> is text format in -XXX XXXXXXXXXXXXXXX

Example: Input command VOLTage 2w will cause error. SYSTem:ERR? returns error code "-148," and sending SYSTem:ERR? again returns no error code "0,". Refer to Table B-4 for a complete list of error codes.

**TABLE B-4. ERROR CODES**

Error Code	Explanation
0, "No error"	No error
-102, "Syntax error"	An unrecognized command or data type was encountered; for example, a string was received when the device does not accept strings.
-104, "Data type error"	The parser recognized a data element different than one allowed; for example, numeric or string data was expected but block data was encountered.
-108, "Parameter not allowed"	More parameters were received than were expected.
-109, "Missing parameter"	Fewer parameters were received than required for the header; for example, the SYST:BEEP command requires one parameter, so SYST:BEEP is not allowed, while SYST:BEEP ON is allowed.
-113, "Undefined header"	A command was received that was not valid for this instrument.
-114, "Header suffix out of range"	The value of the numeric suffix is not valid.
-130, "Suffix error"	Generic suffix error
-148, "Character data not allowed"	A discrete parameter was received, but a string or numeric parameter was expected.
-158, "String data not allowed"	A character string was received, but is not allowed for this command.
-221, "Settings conflict"	Indicates that a legal program data element was parsed but could not be executed due to the current device state

**TABLE B-4. ERROR CODES (CONTINUED)**

Error Code	Explanation
-222, "Parameter out of range"	Indicates that a legal program data element was parsed but could not be executed because the interpreted value was outside the legal range as defined by the device.
-410, "Query Interrupted"	A condition causing an interrupted query error occurred.
-501, "IP address conflict"	The desired IP address is already in use in the network.
-502, "Queue Overflow"	MCU memory space is not enough.
70, "ADC/DAC fault"	AD Converter or DA Converter fault
71, "OVP"	Overvoltage protection error: a. The output voltage exceeds the OVP value. b. If optional analog interface installed and in use, this error indicates Analog Programming input used to set output voltage would result in voltage that is higher than OVP value.
72, "OCP"	Output current exceeds the programmed OCP value.
73, "Remote Sensing Over"	The max. compensation voltage is 5V d-c (the sum of two wires, i.e. 2.5V d-c for each).
74, "Module A fault"	DC to DC converter module A failed (including input voltage too low, PFC circuit failed, DC to DC converting circuit failed, or MOSFET of output section failed). Module A is installed in 10kW/15kW models.
75, "Module B fault"	DC to DC converter module B failed (including input voltage too low, PFC circuit failed, DC to DC converting circuit failed, or MOSFET of output section failed). Module B is installed in 5kW/15kW models.
76, "Module C fault"	DC to DC converter module C failed (including input voltage too low, PFC circuit failed, DC to DC converting circuit failed, or MOSFET of output section failed). Module C is installed in 10kW/15kW models.
77, "Module A A-C fail"	AC line input of Module A is abnormal. (Possibly Fuse open, Input phase loose). Module A is installed in 10kW/15kW models.
78, "Module B A-C fail"	AC line input of Module B is abnormal. (Possibly Fuse open, Input phase loose). Module B is installed in 5kW/15kW models.
79, "Module C A-C fail"	AC line input of Module C is abnormal. (Possibly Fuse open, Input phase loose), Module C is installed in 10kW/15kW models.
80, "OTP"	The surface temperature of heatsink (PFC or Buck) too high.
81, "interlock Error"	When the Interlock function is enabled (see PAR. 3.4.14), error occurs if connection between pin 1 and pin 6, 7, 8, or 9 is open.
82, "External Shutoff"	When the external on/off function is enabled (see PAR. 3.4.14 and 3.7.1), error occurs if connection between pin 2 and pin 6, 7, 8, or 9 is open.
83, "AUX power fault"	The auxiliary power failed.
84, "Slave not identical"	Slave unit is not the same model number as Master.
85, "Unknown Slave SN"	Refer to PAR. 2.8.2.2. Master unit will recognize all the Slave units when it is powered on in the proper sequence. If one or more Slave unit is subsequently added to the existing parallel network the error code arises.
86, "M/S comm. fail"	Master/Slave control failed (possibly wrong wiring or more than one unit in the network is set to be Master).
87, "OPP"	Overpower protection tripped

**TABLE B-4. ERROR CODES (CONTINUED)**

Error Code	Explanation
88, “OCP by hardware”	The output current exceeds 120% of rated current, this OCP value is restricted by hardware and not adjustable.
201, “Store memory error”	EEPROM access failed.
202, “Missing Controller”	Signal controller is not response.
203, “Expansion board fault”	Optional interface card failed.
[n]070, “Slave-0[n] ADC-DAC fault” <sup>(1)</sup>	AD Converter or DA Converter fault
[n]071, “Slave-0[n] OVP” <sup>(1)</sup>	Overvoltage protection error: a. The output voltage exceeds the OVP value. b. If optional isolated analog interface installed and in use, this error indicates Analog Programming input used to set output voltage would result in voltage that is higher then OVP value.
[n]072, “Slave-0[n] OCP” <sup>(1)</sup>	Output current exceeds the programmed OCP value.
[n]073, “Slave-0[n] Remote Sensing Over” <sup>(1)</sup>	The max. compensation voltage is 5V d-c (the sum of two wires, i.e. 2.5V d-c for each).
[n]074, “Slave-0[n] Module A fault” <sup>(1)</sup>	DC to DC converter module A failed (including input voltage too low, PFC circuit failed, DC to DC converting circuit failed, or MOSFET of output section failed). Module A is installed in 10kW/15kW models.
[n]075, “Slave-0[n] Module B fault” <sup>(1)</sup>	DC to DC converter module B failed (including input voltage too low, PFC circuit failed, DC to DC converting circuit failed, or MOSFET of output section failed). Module B is installed in 5kW/15kW models.
[n]076, “Slave-0[n] Module C fault” <sup>(1)</sup>	DC to DC converter module C failed (including input voltage too low, PFC circuit failed, DC to DC converting circuit failed, or MOSFET of output section failed). Module C is installed in 10kW/15kW models.
[n]077, “Slave-0[n] Module A A-C fail” <sup>(1)</sup>	AC line input of Module A is abnormal. (Possibly Fuse open, Input phase loose). Module A is installed in 10kW/15kW models.
[n]078, “Slave-0[n] Module B A-C fail” <sup>(1)</sup>	AC line input of Module B is abnormal. (Possibly Fuse open, Input phase loose). Module B is installed in 5kW/15kW models.
[n]079, “Slave-0[n] Module C A-C fail” <sup>(1)</sup>	AC line input of Module C is abnormal. (Possibly Fuse open, Input phase loose), Module C is installed in 10kW/15kW models.
[n]080, “Slave-0[n] OTP” <sup>(1)</sup>	The surface temperature of heatsink (PFC or Buck) too high.
[n]083, “Slave-0[n] 24V fault” <sup>(1)</sup>	24V fault
[n]084, “Slave-0[n] M/S comm. fail” <sup>(1)</sup>	Master/Slave communication failure.
(1 [nn] = Slave number of master/slave configuration. E.g., Error Code 01070 for Slave-01 ADC-DAC fault, 02070 for Slave-02 ADC-DAC fault, etc.	

**B.123 SYSTem:LOCaL COMMAND**

**SYST:LOC**

Syntax:Short Form: SYST:LOC

Long Form: SYSTem:LOCaL

Description:**Sets the power supply to be in local mode.** The front panel REM (Remote) indicator goes off and the front panel controls are enabled.

Argument: None

Example: SYSTem:LOCaL puts the power supply in local mode.

### B.124 SYSTem:LOG:LAST? QUERY

## SYST:LOG:LAST?

Syntax: Short Form: SYST:LOG:LAST?

Long Form: SYSTem:LOG:LAST?

Description: **Returns the date and time of the last logged entry.**

Return Format: {YYYY/MM/DD HH:MM/SS, "description" where YYYY is the year, MM is the month, DD is the day, HH is the hour, MM is the minute, and SS is the second that the entry was logged. "description" explains what action was logged at the date and time.

Example: SYSTem:LOG:LAST?

### B.125 SYSTem:LOG:PREV? QUERY

## SYST:LOG:PREV?

Syntax: Short Form: SYST:LOG:PREV?

Long Form: SYSTem:LOG:PREV?

Description: **Returns the date and time of the last previous logged entry. Must be preceded by either SYST:LOG:LAST? or SYST:LOG:PREV?**

Return Format: {YYYY/MM/DD HH:MM/SS, "description" where YYYY is the year, MM is the month, DD is the day, HH is the hour, MM is the minute, and SS is the second that the entry was logged. The "description" explains what action was logged at the date and time.

Example: To see the last three logged entries, send:  
SYSTem:LOG:LAST? Returns last logged entry.  
SYSTem:LOG:PREV? Returns next to last logged entry.  
SYSTem:LOG:PREV? Returns 2nd to last logged entry.

### B.126 SYSTem:MS:MODE COMMAND

## SYST:MS:MODE

Syntax: Short Form: SYST:MS:MODE { INDE | MAST | SLAV }

Long Form: SYSTem:MS:MODE { INDEpendent | MASTer | SLAVe }

Description: **Allows units to be configured for either independent (standalone) operation, or as a Master or Slave in a parallel configuration.**

Argument:: <INDEpendent> Configures the unit for independent operation.  
<MASTer> Configures the unit to function as a Master in a parallel master./slave configuration.  
<SLAVe> Configures the unit to function as a Slave in a parallel master./slave configuration.

Example: SYST:MS:MODE MAST configures the unit to function as a Master in a master/slave parallel configuration.

### B.127 SYSTem:MS:MODE? QUERY

## SYST:MS:MODE?

Syntax: Short Form: SYST:MS:MODE?

Long Form: SYSTem:MS:MODE?

Description: **Indicates how the unit is configured.**

Return Format: <INDE> for Independent operation, <MAST> for Master in master/slave parallel configuration or <SLAV> for Slave in master/slave parallel configuration

Example SYST:MS:MODE? returns INDE to indicate the unit is configured for independent operation.

### B.128 SYSTem:MS:NUMber? QUERY

## SYST:MS:NUM?

Syntax: Short Form: SYST:MS:NUM?

Long Form: SYSTem:MS:NUMber?

Description: **Indicates how many units are connected in parallel**

Return Format: <NR1> is a number between 2 and 5 indicating the number of units connected in parallel,

Example: SYST:MS:MODE:NUM? returns 2 to indicate 2 units are configured in a parallel configuration.

### B.129 SYSTem:NTP COMMAND

## SYST:NTP

Syntax:Short Form: SYST:NTP { ON | OFF | 1 | 0 }  
Long Form: SYSTem:NTP { ON | OFF | 1 | 0 }

Description:**Enables or disables automate updating of time from the NTP (Network Time Protocol) Server.**

Argument:<ON> or 1 enables NTP Server.  
<OFF> or 0 disables NTP Server.

Example:SYSTem:NTP 1 enables NTP Server.

### B.130 SYSTem:NTP? QUERY

## SYST:NTP?

Syntax:Short Form: SYST:NTP? Long Form: SYSTem:NTP?

Description:**Indicates whether automatic update of time is on or off.** Returns 1 to indicate the NTP Server is enabled, 0 to indicate NTP Server is disabled.

Return Format:{ ON | OFF }

Example:SYSTem:NTP? returns ON (NTP Server is enabled).

### B.131 SYSTem:NTP:SERV COMMAND

## SYST:NTP:SERV

Syntax:Short Form: SYST:NTP:SERV <IP address>  
Long Form: SYSTem:NTP:SERV <IP address>

Description:**Enables or disables automate updating of time from the NTP (Network Time Protocol) Server.**

Argument:<IP address> IP address of the NTP Server

Example:SYST:NTP:SERV "66.199.22.67" sets the IP address of the NTP Server to 66.199.22.67.

### B.132 SYSTem:NTP:SERV? QUERY

## SYST:NTP:SERV?

Syntax:Short Form: SYST:NTP:SERV? Long Form: SYSTem:NTP:SERV?

Description:**Indicates the programmed IP address for the NTP Server.** Returns <IP address>

Return Format:<IP address> IP address of the NTP Server

Example:SYSTem:NTP? returns "66.199.22.67" indicating the IP address of the NTP Server is 66.199.22.67.

### B.133 SYSTem:REMOte COMMAND

## SYST:REM

Syntax:Short Form: SYST:REM Long Form: SYSTem:REMOte

Description:**Sets the power supply to be in remote mode.** The front panel REM (remote) indicator lights and the unit accepts remote commands. Pressing and holding the HOME button for more than 1.5 seconds restores the unit to local mode.

Argument: None

Example: SYSTem:REM puts the power supply in remote mode.

### B.134 SYSTem:RWLock COMMAND

## SYST:RWL

Syntax:Short Form: SYST:RWL Long Form: SYSTem:RWLock

Description:**Sets the power supply to be in remote mode with front panel controls disabled.** The front panel REM (remote) indicator lights and the front panel controls and encoders are disabled. Pressing HOME on the front panel does not restore the unit to local mode. The unit is restored to local mode if the SYST:LOC command is issued or power to the unit is cycled.

Argument: None

Example: SYST:RWL puts the power supply in remote mode with front panel controls disabled.

## SYST:TIME

### B.135 SYSTem:TIME COMMAND

Syntax: Short Form: SYST:TIME "HH:MM:SS"  
 Long Form: SYSTem:TIME "HH:MM:SS"

Description: **Sets the time of the internal clock to be displayed on the front panel touchscreen display.**

Argument:: <HH> sets hours.  
 <MM> sets minutes.  
 <SS> sets seconds.

Example: SYST:TIME 09:15:00 sets the time to 9:15AM.

## SYST:TIME?

### B.136 SYSTem:TIME? QUERY

Syntax: Short Form: SYST:TIME? Long Form: SYSTem:TIME?

Description: **Indicates the time of the internal clock**

Return Format: "HH:MM:SS" where <HH> is the hour, MM is the minute, and SS is the second.

Example: SYST:TIME? returns 23:30:00 to indicate the time is 11:30PM.

## SYST:VERS?

### B.137 SYSTem:VERSion? QUERY

Syntax: Short Form: SYST:VERS? Long Form: SYSTem:VERSion?

Description: **Indicates the SCPI version to which unit complies.**

Return Format: <string> where <string> is text in XXXX.X format corresponding to SCPI year and revision.

Example: SYST:VERS? returns 1990.0 (unit complies with SCPI version 1990.0.)

## SYST:ZONE

### B.138 SYSTem:ZONE COMMAND

Syntax: Short Form: SYST:ZONE <UTC>  
 Long Form: SYSTem:ZONE <UTC>

Description: **Sets the Universal Coordinated Time zone of the internal clock.**

Argument:: <UTC> Represents the standard offsets:

UTC-12:00	UTC-07:00	UTC-03:00	UTC+02:00	UTC+05:00	UTC+07:00	UTC+11:00
UTC-11:00	UTC-06:00	UTC-02:00	UTC+03:00	UTC+05:30	UTC+08:00	UTC+12:00
UTC-10:00	UTC-05:00	UTC-01:00	UTC+03:30	UTC+05:45	UTC+09:00	UTC+13:00
UTC-09:00	UTC-04:00	UTC	UTC+04:00	UTC+06:00	UTC+09:30	UTC+14:00
UTC-08:00	UTC-03:30	UTC+01:00	UTC+04:30	UTC+06:30	UTC+10:00	

Example: SYST:ZONE UTC-05:00 sets the time zone to EST (Eastern Standard Time).

## SYST:ZONE?

### B.139 SYSTem:ZONE? QUERY

Syntax: Short Form: SYST:ZONE? Long Form: SYSTem:ZONE?

Description: **Indicates the time zone of the internal clock**

Return Format: <UTC> See above for standard offsets

Example: SYST:TIME? returns UTC-05:00 to indicate the time zone is EST (Eastern Standard Time).