

INSTRUCTION MANUAL

PAT 40-0.5 MODULAR POWER SUPPLY

KEPCO INC.
An ISO 9001 Company.

MODEL PAT 40-0.5 POWER SUPPLY

ORDER NO.

REV. NO

IMPORTANT NOTES:

- 1) This manual is valid for the following Model and associated serial numbers:

MODEL	SERIAL NO.	REV. NO.
-------	------------	----------

- 2) A Change Page may be included at the end of the manual. All applicable changes and revision number changes are documented with reference to the equipment serial numbers. Before using this Instruction Manual, check your equipment serial number to identify your model. If in doubt, contact your nearest Kepco Representative, or the Kepco Documentation Office in New York, (718) 461-7000, requesting the correct revision for your particular model and serial number.
- 3) The contents of this manual are protected by copyright. Reproduction of any part can be made only with the specific written permission of Kepco, Inc.

Data subject to change without notice.

©2018, KEPCO, INC.
P/N 243-0374R15b



TABLE OF CONTENTS

PARAGRAPH		PAGE
SECTION I – INTRODUCTION		
1-1	Scope of Manual	1-1
1-3	General Description	1-1
1-6	Spceifications, General	1-1
1-7	Specifications, Electrical Performance	1-2
1-8	Accessories	1-3
1-9	Specifications, Physical	1-3
SECTION II – INSTALLATION		
2-1	Unpacking and Inspection	2-1
2-3	Terminations	2-1
2-5	A-C Power Requirements	2-1
2-7	Grounding	2-2
2-9	Operational Check	2-2
SECTION III – OPERATION		
3-1	Standard Power Supply Operation	3-1
3-7	Introduction to Programming	3-2
3-9	Equations Showing the Operation of the Kepco Bridge	3-3
3-11	Adjustments for Exact Programming Ratio	3-3
3-16	Programming Output Voltage with Resistance	3-4
3-19	Stabilized Current Operation	3-5
3-24	Programming by Conductance	3-7
3-28	Programming with External Voltage	3-8
3-33	Series Operation of PAT Modules	3-9
3-36	Parallel Operation of PAT Modules	3-10
3-39	Voltage Programming with Noninverting Input	3-11
3-43	Remote Current Limiting	3-12
SECTION IV – THEORY OF OPERATION		
4-1	Simplified Diagram Discussion	4-1
4-4	Circuit Description	4-1
SECTION V – MAINTENANCE		
5-1	General	5-1
5-3	Disassembly	5-1
5-5	Internal Adjustment Procedures	5-1
5-7	Installation and Adjustment of (Optional) Voltage Control	5-2
5-8	Trouble Shooting	5-3
5-13	Power Supply Measurements	5-3
SECTION VI – ELECTRICAL PARTS LIST AND SCHEMATIC		
6-1	General	6-1/6-2
6-3	Ordering Information	6-1/6-2

LIST OF ILLUSTRATIONS

FIGURE		PAGE
1-1	PAT Power Supply	iii/iv
1-2	Mechanical Outline Drawing	1-4
2-1	Termination and Standard Jumper-Link Connection	2-1
2-2	Conversion to 230V A-C Operation	2-1
2-3	Location of Grounding Lug	2-2
2-4	Operational Checkout	2-2
3-1	Connections for Fixed Output Operation	3-1
3-2	Load Connection with Remote Error Sensing	3-1
3-3	Connection for Variable Output Voltage	3-2
3-4	Keboo Power Supply and Comparison Bridge Circuit	3-2
3-5	Connections for Precision Programming Adjustments	3-4
3-6	Establishing Programming Linearity	3-4
3-7	Connections for Resistance Programming	3-5
3-8	Connections for Stabilized Current Operation	3-6
3-9	Connections for Conductance Programming	3-7
3-10	Connections for Voltage Programming	3-9
3-11	Series Connection of PAT Supplies	3-10
3-12	Parallel Operation, PAT Supplies	3-10
3-13	Parallel Connection, PAT Power Supplies	3-11
3-14	Connections for Noninverting Programming	3-12
3-15	Connections for Remote Current Limit Control	3-12
3-16	Simplified Connection Diagram, PAT Models (fold-out)	3-13/3-14
4-1	Simplified Diagram, PAT Power Supply	4-1
5-1	Disassembly, PAT Group	5-1
5-2	Installation of (Optional) Voltage Control	5-2
5-3	Power Supply Measurements, Connecting Methods	5-5/5-6
5-4	Approximation of a Four-Terminal Network	5-5/5-6
6-1	Component Location, Main Chassis.	6-9
6-2	Component Location, Printed Circuit Board.	6-10
6-3	Main Schematic.	6-11/6-12

LIST OF TABLES

TABLE		PAGE
1-1	PAT Series, Output Specifications and A-C Input Current Requirements	1-2
1-2	Electrical Performance Specifications	1-3

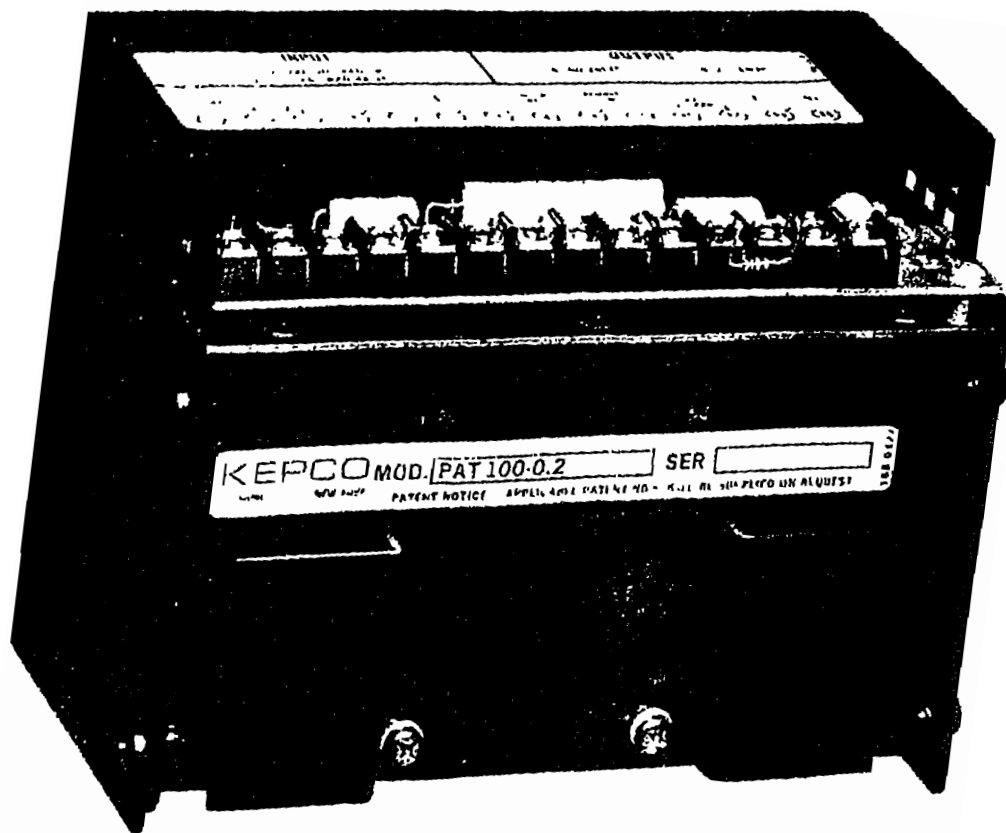

FIG. 1-1 PAT POWER SUPPLY (TYPICAL).

SECTION I -INTRODUCTION

1-1 SCOPE OF MANUAL

1-2 This manual contains instructions for the installation, operation, and maintenance of the Kepco PAT Series of power supplies.

1-3 GENERAL DESCRIPTION

1-4 The Kepco PAT Series of *programmable power supplies* consists of a group of modular units with identical *outside dimensions* (refer to FIG's. 1-1, 1-2) and electrical specifications except as noted in TABLE 1-1.

1-5 Features of the Kepco PAT Series include short-circuit proof design by means of an extremely sharp current limit circuit, provisions for full-range programming and all silicon design with conservatively rated components for added reliability. The NPN output transistors are driven by a monolithic, linear IC amplifier. Kepco PAT modules may be readily adapted to provide stabilized *output current* by adding external sensing and control resistors, refer to Section III. Other features for the Kepco PAT Series power supplies include:

- a) Built-in Control Current adjustment (I_b Adj., R16).
- b) Precision zero adjustment (E_{i0} Null, R10).
- c) Current Limit adjustment (I_o Limit Adj., R19).

NOTE: PAT models with suffix "20000", e.g. "Model PAT 40-0.5-20000", have a built-in output voltage control rheostat (R_{vc} , R13). On standard PAT models the voltage control resistor must be provided externally.

1-6 SPECIFICATIONS, GENERAL

- a) INPUT: 105 to 125V a-c or 210 to 230V a-c (selectable, refer to par. 2-5). 50 to 440 Hz, single phase. See TABLE 1-1 for the input current on each model.
- b) OPERATING TEMPERATURE: - 20°C to +71°C.
- c) STORAGE TEMPERATURE: - 40°C to + 85°C.
- d) COOLING: Convection.
- e) ISOLATION VOLTAGE. A maximum of 500V (d-c or p-p) can be connected between chassis and either output terminal. Common mode current from either output terminal to ground $5\mu A$ rms, $50\mu A$ peak to peak at 115V a-c input, 60 Hz.
- f) VOLTAGE CONTROL: PAT modules are ordinarily supplied without a voltage control. External fixed or variable programming resistors are used to control the output. Optionally, on PAT Models with suffix "20000" a built-in trimmer is provided for up to 20 volts adjustment range. * Stability and temperature coefficient criteria require the use of high quality, low T.C. (20 ppm/min.) wirewound elements for programming.
- g) PROGRAMMING: Terminals provide for resistive programming of voltage or current at approximately 1000 ohms per volt. Programming terminals are also provided for programming by means of remotely located voltage or current signals. Built-in trimmers are provided to adjust the control ratio over a 10% range and set the power supply to exactly zero volts, so that exact value fixed programming resistances can be used conveniently. See pars. 1-5b and 1-5c).
- h) CURRENT LIMIT CONTROL: A single-turn control provides adjustable current limiting from 10% to 105% of rated full load current.

* Inquire at factory.

- i) **SHORT-CIRCUIT PROTECTION.** Unique current limiting circuitry permits continuous operation into a short circuit without the aid of fuses, circuit breakers, or relays. Output returns to the operating voltage when the overload is removed.
- j) **REMOTE ERROR SENSING:** Error-sensing terminals enable specified voltage regulation to be maintained directly at the load by compensating for voltage drops up to 0.5 volts across each load supply lead.
- k) **SERIES/PARALLEL OPERATION:** Series connection of identical units is possible up to the specified isolation voltage limit, and provided the necessary precautions are taken. (See par. 3-33.) PAT supplies can be parallel connected and will share the load by means of their current limiting feature. (See par. 3-36.)
- l) **COOLING:** Heat removal is by natural convection without blowers.
- m) **OVERSHOOT:** No output voltage overshoot from turn-on, turn-off, or power failure for output settings above 25% maximum rated output voltage. Below 25%, output voltage overshoot is a function of load current and is negligible for loads in excess of 10% of the maximum rated load current.

1-7 SPECIFICATIONS, ELECTRICAL PERFORMANCE

- a) Refer to TABLES 1-1 and 1-2.

MODEL	D-C OUTPUT RANGE		OUTPUT IMPEDANCE OHMS + MICROHENRYS			MAX. INPUT AMPS at 125 V A-C
	VOLTS	AMPS	D-C to 100 Hz	100 Hz to 1 kHz	1 kHz to 100 kHz + μ H	
PAT 7-2	0-7	0-2	0.2×10^{-3}	0.02	0.1 + 1	0.50
PAT 15-1.6	0-15	0-1.5	0.5×10^{-3}	0.02	0.1 + 1	0.65
PAT 21-1	0-21	0-1	1×10^{-3}	0.02	0.1 + 1	0.45
PAT 40-0.5	0-40	0-0.5	4×10^{-3}	0.02	0.1 + 1	0.40
PAT 72-0.3	0-72	0-0.3	12×10^{-3}	0.02	0.1 + 1	0.45
PAT 100-0.2	0-100	0-0.2	25×10^{-3}	0.02	0.1 + 1	0.45

TABLE 1-1 OUTPUT SPECIFICATIONS AND A-C INPUT CURRENT REQUIREMENTS.

NOTE: Kepco has adopted new technical terms recommended by the International Electrotechnical Commission (IEC). These terms replace or supplement previously used expressions, mainly to avoid difficulties in translation and prevent erroneous interpretations at home and abroad.

In this instruction manual Kepco discontinued the use of the specifications entitled "line regulation" and "load regulation" because of the long standing (and misleading) connotation that a power supply regulates the line or the load. Instead, Kepco will follow the recommendation of the IEC and speak of the "Output Effects, caused by changes in the Influence Quantities." The "Output Effects" are specified either as a percentage change referred to the maximum specified output voltage (E_0) or current (I_0) or as an absolute change ($\Delta E_0, \Delta I_0$) directly in millivolts or milliamperes or both. The "Influence Quantities" are the "Source Variations" (formerly a-c line variations), the changes in load, temperature or time as previously specified. The illustration below will clarify the use of the new terminology.

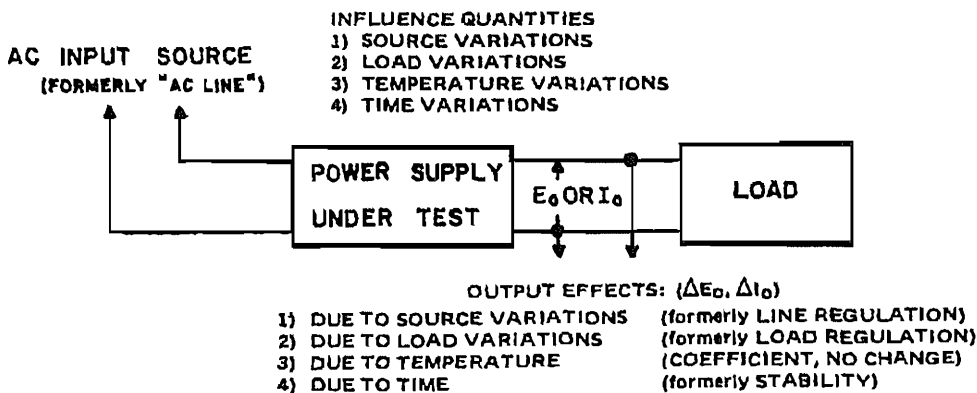

SPECIFICATION	OUTPUT EFFECTS		VOLTAGE AMPLIFIER OFFSET VARIATIONS****		VOLTAGE-REFERENCE (Internal)****
	VOLTAGE MODE	CURRENT MODE***	OFFSET VOLTAGE ΔE_{i0}	OFFSET CURRENT ΔI_{i0}	
OUTPUT RANGE:	0–100% E_0 max.	1 mA–100% I_0 max.	—	—	Fixed 6.2V $\pm 5\%$
SOURCE: 105–125/210–250V a-c	< 0.0005%	< 0.005%	< 10 μ V	< 2 nA	0.0001%
LOAD: No load – full load	< 0.005% or 0.2 mV*	< 0.01%	< 200 μ V	< 5 nA	—
TIME: 8-hour (drift)	< 0.01% or 1 mV*	< 0.02%	< 20 μ V	< 2 nA	0.005%
TEMPERATURE: Per $^{\circ}$ C	< 0.01%	< 0.02%	< 20 μ V	< 5 nA	0.005%
RIPPLE: (rms)	< 0.1 mV	< 0.02% of I_0 max.	—	—	—
RIPPLE: (P-P 20 Hz to 10 MHz)	< 0.5 mV	< 0.1% of I_0 max.	—	—	—

*NOTE: Whichever is greater.

***NOTE: Current mode output effects (ΔI_0) are measured across the external sensing resistor. This resistor must be a high quality, wirewound unit, with a wattage at least 10 times the actual power dissipated, have a temperature coefficient of 20 parts per million or better and drop a sample voltage of 1.0 volt at the measuring current. A resistor built as a 4-terminal network is recommended. Current control is exercised with an external 20 ppm feedback resistor.

****Offset and reference variations (ΔE_{i0} , ΔI_{i0} , ΔE_f) contribute to output effect (ΔE_0) according to the equation:

$$\Delta E_0 = \pm \Delta E_{ref} (R_f/R_i) \pm \Delta E_{i0} (1 + R_f/R_i) \pm \Delta I_{i0} (R_f)$$

where R_f is the feedback resistor and R_i is the input resistor from the signal reference. Use the offset variations to calculate output effects when selecting external input/feedback elements or if the internal reference is replaced by a programming signal.

TABLE 1-2 ELECTRICAL PERFORMANCE SPECIFICATIONS.

1-8 ACCESSORIES (OPTIONAL, NOT SUPPLIED)

- One-unit rack adapter, Kepco Model RA 26–1.
- Two-unit rack adapter, Kepco Model RA 27–2.
- Four-unit rack adapter, Kepco Model RA 28–4.

1-9 PHYSICAL SPECIFICATIONS

- Refer to "Mechanical Outline Drawing," FIG. 1-2

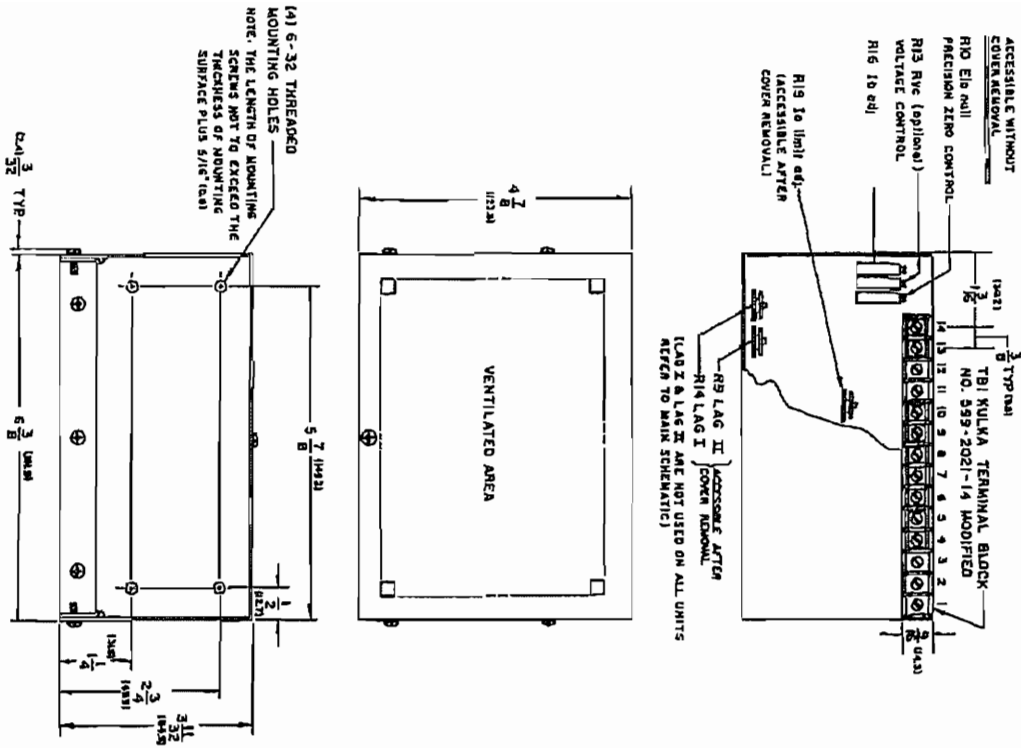

- TR-1 TERMINAL FUNCTIONS:
1. AC (HOT)
 2. AC (NEUTRAL)
 3. AC (GROUND)
 4. (-) ERROR SENSING
 5. (-) OUTPUT
 6. (+) OUTPUT
 7. (+) ERROR SENSING
 8. NON-INVERTING INPUT
 9. EXTERNAL CURRENT LIMIT CONTROL
 10. EXTERNAL VOLTAGE CONTROL
 11. EXTERNAL CURRENT CONTROL ADJ.
 12. EXTERNAL CURRENT CONTROL
 13. EXTERNAL CURRENT CONTROL
 14. EXTERNAL CURRENT CONTROL

- NOTES:
1. THIS DRAWING IS USED FOR THE MODELS PAT 7-2, PAT 18-1.5, PAT 21-1, PAT 40-0.5, PAT 72-0.3 & PAT 100-0.2
 2. MATERIAL: CHASSIS: 11 GA. (090) ALUMINUM, COVER: 16 GA. (090) ALUMINUM.
 3. FINISH: BLACK ANODIZED
 4. FUSE: DATA: 115 VAC -1AMP INST. 230 VAC -0.5 AMP INST.
 5. DIMENSIONS IN PARENTHESES ARE IN MILLIMETERS.
 6. TOLERANCES: A) BETWEEN MOUNTING HOLES $\pm 1/64 \pm 0.4$ B) ALL FRONT PANEL DIMENSIONS TO MIL. STD. 189. C) ALL OTHER DIMENSIONS ± 0.002 , EXCEPT AS NOTED.

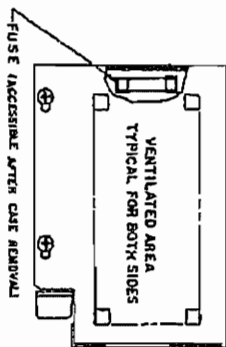

FIG. 1-2 MECHANICAL OUTLINE DRAWING.

SECTION II – INSTALLATION

2-1 UNPACKING AND INSPECTION

2-2 This power supply has been inspected and tested at the factory prior to packing and is shipped ready for operation. After careful unpacking, inspect the instrument for shipping damage before attempting to operate it. Perform an operational check as described below. (See par. 2-9.) If there is any indication of damage, file a claim immediately with the responsible transport service.

2-3 TERMINATIONS

2-4 All input and output connections on the PAT power supplies are made on the 14-terminal barrier-strip as shown in FIG. 2-1.

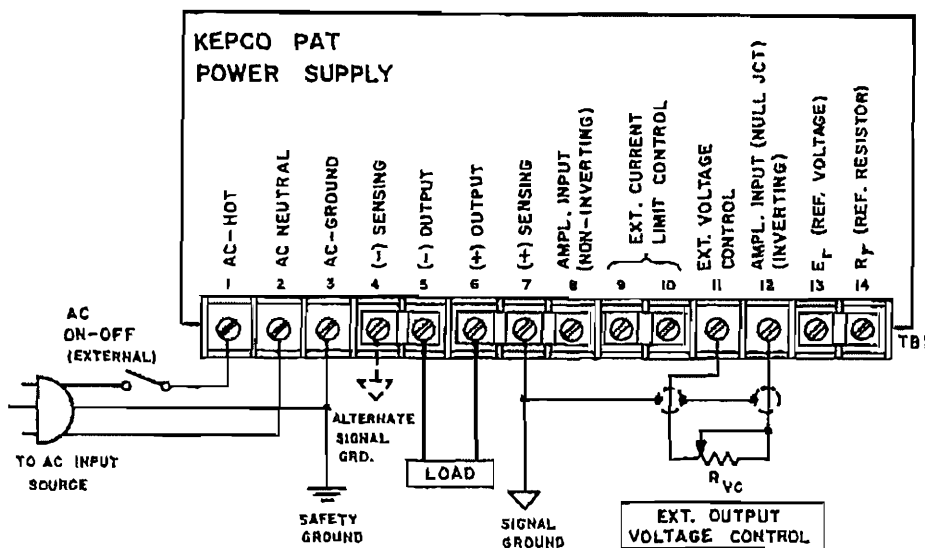

NOTES:

- 1) The jumper links on TB1 must be securely connected as shown in the figure.
- 2) Connect load and external R_{vc} as shown before applying a-c input.

ATTENTION!
A FOLD-OUT DIAGRAM IS PROVIDED AT THE END OF SECTION III (FIG. 3-16), RELATING THE BARRIER-STRIP CONNECTIONS TO THE CIRCUITRY OF THE PAT POWER SUPPLY.

FIG. 2-1 TERMINATIONS AND STANDARD JUMPER-LINK CONNECTIONS.

2-5 A-C POWER REQUIREMENTS

2-6 This power supply is normally shipped for operation from a nominal 115V a-c source, single phase. If 230V a-c operation is desired, the transformer primary link connections must be changed as shown in FIG. 2-2.

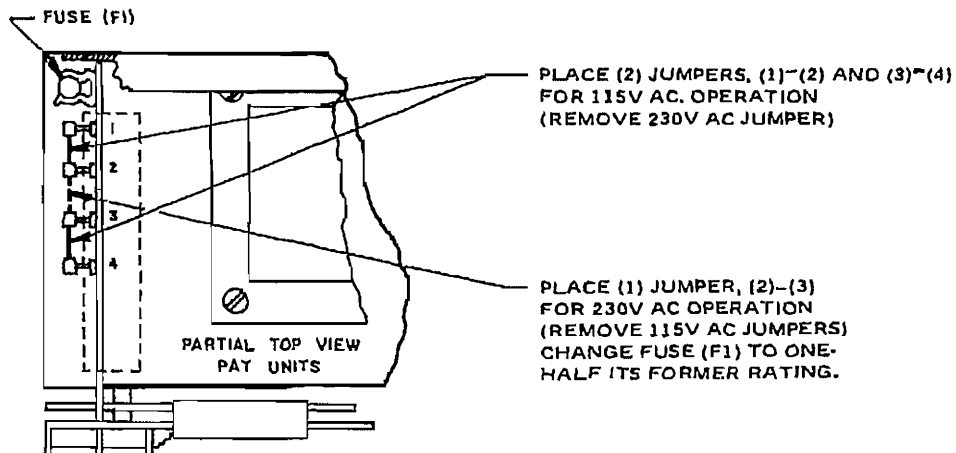

FIG. 2-2 CONVERSION TO 230V A-C OPERATION.

4. GROUNDING

- 2-8 a) **SAFETY GROUND.** For safety reasons it is important that the metal chassis of the PAT power supply be connected to an a-c ground. If a 3-wire line cord and a properly grounded outlet are used, the grounding is automatically accomplished. If only a 2-wire line cord is used, the metal chassis of the power supply must be grounded separately by returning barrier-strip terminal (3) to an a-c ground.
- b) **SYSTEM GROUND.** The d-c output terminals of the PAT power supplies are isolated from the a-c power line and from the chassis, except for a capacitor/resistor series connection from the negative (-) output to chassis. Since no d-c connection exists to the chassis, either side of the power supply may be grounded. A maximum of 500V (d-c or p-p) can be connected between chassis and either output terminal. If the provided internal capacitor/resistor connection from (-) output to chassis is not desired, and the positive side of the PAT is to be grounded, the system ground may be established outside the power supply by removing the provided flexible grounding lead from the grounding lug and transferring it to the "blind" or ungrounded position. (Refer to FIG. 2-3.) The output of the PAT is now completely "floating," and either the positive or negative may be grounded elsewhere in the system or at the load.

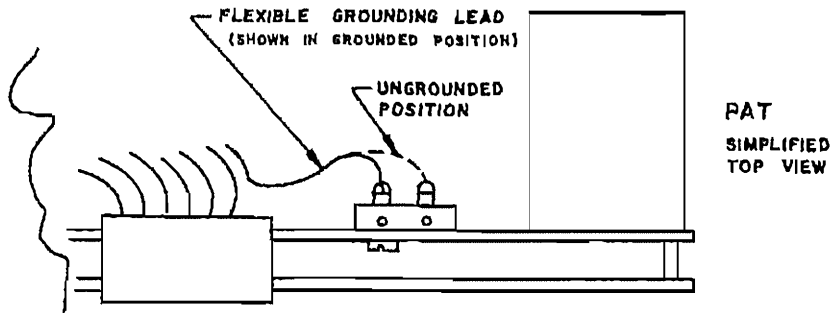

FIG. 2-3 LOCATION OF GROUNDING LUG.

2-9 OPERATIONAL CHECK

- 2-10 After a-c power connections have been made as described in paragraph 2-5, a functional check may be performed as follows:

Connect an external voltmeter (M1) to terminals (5)-(6) as shown in FIG. 2-4. Connect a line cord to terminals (1)-(2) with the ground wire to terminal (3).

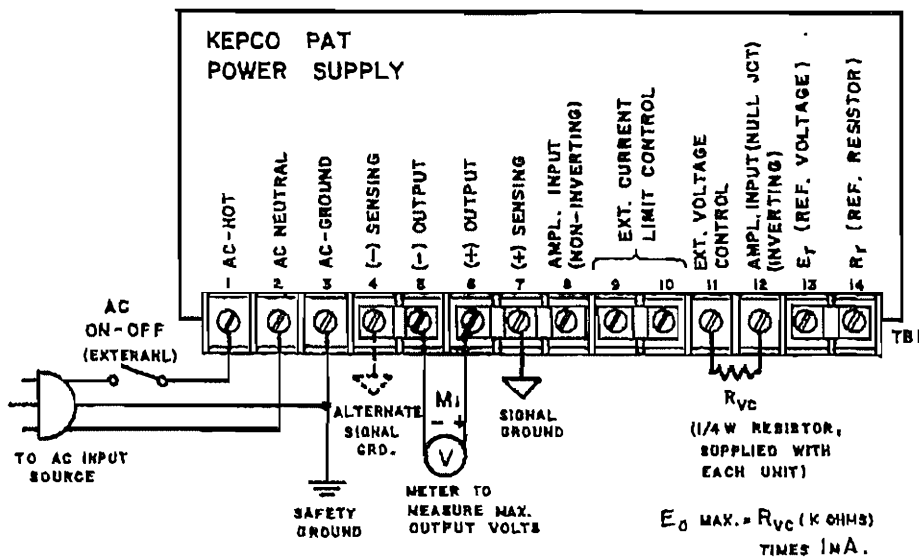

FIG. 2-4 OPERATIONAL CHECKOUT.

NOTES:

- 1) The jumper links on TB1 must be securely connected as shown in the figure.
- 2) Connect load and external R_{VC} as shown before applying a-c input.

ATTENTION!
A FOLD-OUT DIAGRAM IS PROVIDED AT THE END OF SECTION III (FIG. 3-16), RELATING THE BARRIER-STRIP CONNECTIONS TO THE CIRCUITRY OF THE PAT POWER SUPPLY.

- 2-11 The resistor which is connected to terminals (11)-(12) serves as the voltage control resistor (R_{VC}). It is intended for preliminary checkout purposes only. *Regulation and stability measurements require metal film or wirewound resistors with temperature coefficients of 20 ppm or better.* The output voltage measured on M1 should be proportional to the resistance of R_{VC} . Since a nominal 1000 ohm per volt control ratio is used in the PAT power supplies, the output voltage will be approximately equal to 1 mA times the kilohms across terminals (11)-(12). A variable resistor of appropriate value may be used to check the supply over its full output range. This completes the operational test of the PAT power supply.

SECTION III – OPERATION

3-1 STANDARD POWER SUPPLY OPERATION FOR STABILIZED OUTPUT VOLTAGE

3-2 GENERAL. The PAT power supply is shipped from the factory with 5 removable jumper-links in place at the rear barrier-strip (TB1). All links must be in place and secured tightly for standard (local sensing) operation. With the external voltage control resistor (R_{VC}) mounted between terminals (11) and (12) on TB1, the power supply will deliver a minimum rated output voltage equal to R_{VC} (kilohms) X 1 mA.

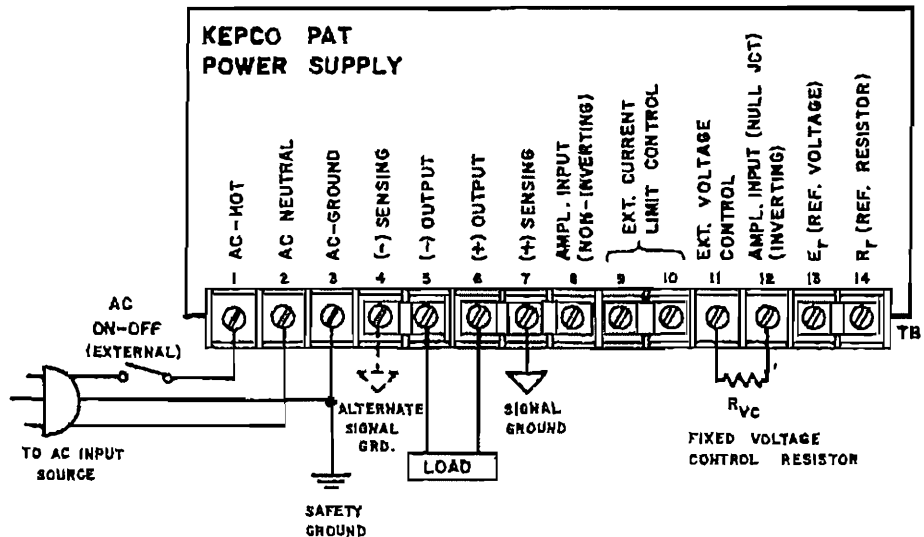

- NOTES:
- 1) The jumper links on TB1 must be securely connected as shown in the figure.
 - 2) Connect load and external R_{VC} as shown before applying a-c input.

ATTENTION!
A FOLD-OUT DIAGRAM IS PROVIDED AT THE END OF SECTION III (FIG. 3-16), RELATING THE BARRIER-STRIP CONNECTIONS TO THE CIRCUITRY OF THE PAT POWER SUPPLY.

FIG. 3-1 CONNECTIONS FOR FIXED OUTPUT OPERATION.

3-3 LOAD CONNECTION. The load may be connected as shown in FIG. 3-1. Load connecting wires should be as heavy as practicable since load wire voltage drops will degrade regulation at the load. Specified power supply performance will in this case be present at the error-sensing terminals (4)–(7). Refer to Section V for correct connections when measuring power supply performance.

3-4 ERROR SENSING. Specified stabilization performance *directly at the load* requires the use of remote error sensing. Error sensing wires should be of the same gage as the load wires and each error sensing lead should be tightly twisted with its respective load wire. (See FIG. 3-2.) Observe polarities. The negative sensing lead from terminal (4) must go to the negative load side.

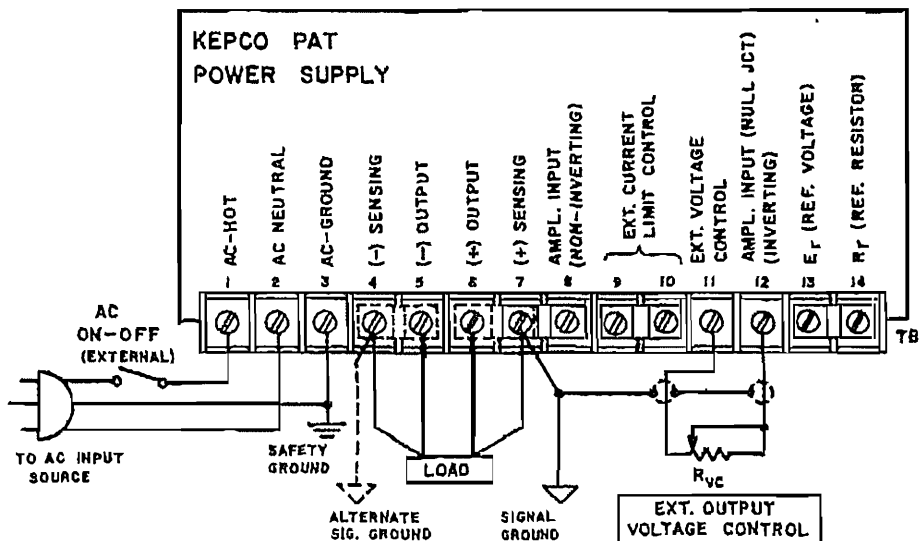
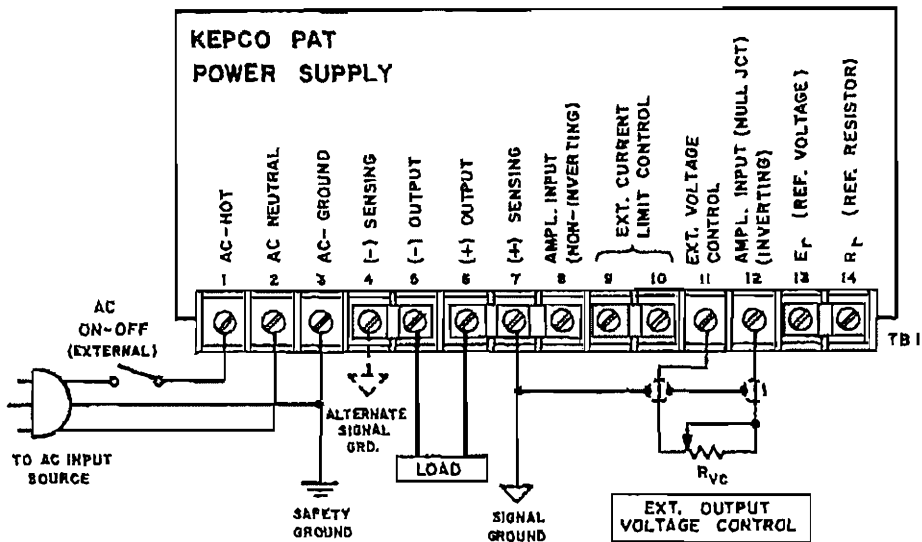

FIG. 3-2 LOAD CONNECTION WITH REMOTE ERROR SENSING.

- 3-5 **TURN-ON.** An a-c source switch may be mounted externally to facilitate connection to and from the power line. If only a single pole switch is used, it should be connected in series with terminal (1), the "hot" side of the power source.
- 3-6 **VARIABLE OUTPUT VOLTAGE.** The output voltage of the PAT power supply may be varied from approximately zero to its maximum rated value by replacing the supplied fixed voltage control resistor by a suitable rheostat. The control ratio (ohms per volt) is approximately 1000 ohms per volt in all PAT power supplies so that for each 1 kilohm of control resistance, 1 volt of output voltage will be available. A good quality, wirewound or metal film potentiometer (rheostat connected) should be used as the voltage control resistance. Shielding of the leads going to the voltage control is recommended to reduce ripple "pickup." (Refer to FIG. 3-3.)



- NOTES:**
- 1) The jumper links on TB1 must be securely connected as shown in the figure.
 - 2) Connect load and external R_{VC} as shown before applying a-c input.

ATTENTION!
A FOLD-OUT DIAGRAM IS PROVIDED AT THE END OF SECTION III (FIG. 3-16), RELATING THE BARRIER-STRIP CONNECTIONS TO THE CIRCUITRY OF THE PAT POWER SUPPLY.

FIG. 3-3 CONNECTION FOR VARIABLE OUTPUT VOLTAGE.

3-7 INTRODUCTION TO PROGRAMMING

3-8 **GENERAL.** A few general remarks may be in order to familiarize the user of this equipment with the terminology and basic equations pertaining to remote programming of the Kepco PAT Power Supplies. Electrically, the power supply consists of the unregulated d-c source (E_U), the pass element (E_P), the d-c error amplifier (A), and a comparison circuit which resembles a 4-arm electrical bridge. (Refer to FIG. 3-4.) The elements of the bridge are arranged to produce a virtual zero at the amplifier input when the bridge circuit is at balance ($V_{AA'} = 0$). Any tendency for the output voltage to change in relation to the reference voltage (E_r) creates an error signal which, by means of negative feedback and the amplifier, tends to correct the output voltage towards restoration of bridge balance.

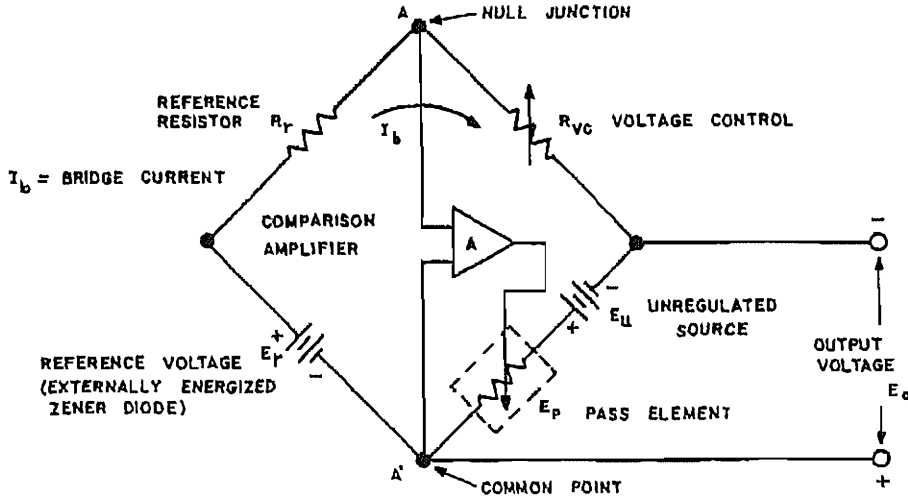

FIG. 3-4 KEPCO POWER SUPPLY AND COMPARISON BRIDGE CIRCUIT.

3-9 EQUATIONS SHOWING THE OPERATION OF THE KEPCO BRIDGE

3-10 The following relationships govern the operation of the Kepco Bridge at balance; i.e., with $V_{AA}' = 0$:

$$a) \quad \frac{E_O}{E_r} = \frac{R_{VC}}{R_r} \quad (1)$$

Where E_O = Output voltage
 E_r = Reference voltage
 R_r = Reference resistance
 R_{VC} = Control resistance
 I_b = Bridge current

$$\frac{E_r}{R_r} = I_b \quad (2)$$

$$E_O = I_b R_{VC} \quad (3)$$

- b) The ratio of the number of ohms control resistance needed per volt output is termed the CONTROL RATIO. It is nominally 1000 ohm/volt in the PAT power supplies.
- c) As can be seen from equation (1), the output voltage E_O can be controlled by varying any one of the three quantities. Rewriting equation (1) we have:

$$E_O = \frac{E_r}{R_r} \times R_{VC}$$

The ratio E_r/R_r constitutes the bridge current, I_b (Eq. 2).

- d) Therefore we can write. $E_O = I_b R_{VC}$ (Eq. 3).

Making I_b a precision quantity (precision bridge current adjustment is described in par. 3-11) establishes a precise programming ratio so that the value of E_O is solely dependent upon R_{VC} . This mode of operation is referred to as RESISTANCE PROGRAMMING and is covered in detail in paragraph 3-16.

- e) Rewriting equation (1), $E_O = E_r (R_{VC}/R_r)$, we can make E_r the variable which controls E_O . This type of control is referred to as VOLTAGE PROGRAMMING and is covered in paragraph 3-28.
- f) Many other modes of control are, of course, possible; some of them are described in the following paragraphs. For a more extensive treatment and a detailed theoretical view of power supply applications, refer to various Kepco technical publications available from your Kepco representative or directly from Kepco Applications Engineering Department.

NOTE: For all programming and adjustment components, use high quality, wirewound resistors with a TC of 20 ppm or better.

3-11 ADJUSTMENTS FOR EXACT PROGRAMMING RATIO

3-12 Referring to equation (3), $E_O = I_b R_{VC}$, it is seen that if $I_b = 1$ mA, 1000 ohms of control resistance (R_{VC}) are needed for each volt of output. Making I_b therefore a precision quantity, the accuracy and linearity of the output voltage will then solely depend upon R_{VC} .

3-13 Again referring to equation (3), we see that if $R_{VC} = 0$ (shorted out), the output voltage should be zero. A small negative offset voltage (in the millivolt range) exists, however, under this condition at the output.

3-14 Both inaccuracies, the slightly larger bridge current (I_b) and the small negative offset voltage, may be adjusted to provide a linear and precise programming ratio.

3-15 PROCEDURE, PRECISION PROGRAMMING RATIO ADJUSTMENT (Refer to FIG. 3-5.)

- a) Equipment required
- 1) Precision digital or differential voltmeter (M1).
 - 2) Precision resistor, accuracy comparable to M1. The value is not important but must be known. For every 1000 ohms, 1 volt will appear across M1 (R_{VC}).

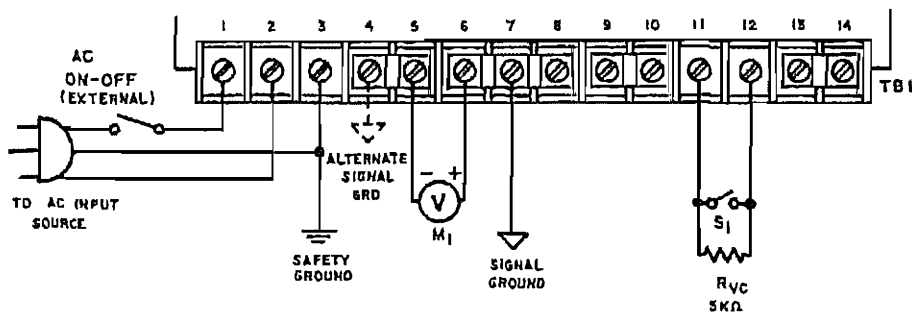

NOTES:

- 1) The jumper links on TB1 must be securely connected as shown in the figure.
- 2) Connect load and external components as shown before applying a-c input.

FIG. 3-5 CONNECTIONS FOR PRECISION PROGRAMMING ADJUSTMENTS.

- 3) Single pole, single throw switch (S1).
- b) Connect calibration setup per FIG. 3-5, and connect the PAT power supply to the a-c power source.
- c) With S1 "open", and $R_{vc} = 5K$ ohms, approximately 5 volts will be read out on M1. Adjust bridge current adjustment (R16) until *exactly* 5 volts are read out on M1.
- d) Close S1 and note deviation from zero on M1 (approximately 2 to 8 mV negative). Adjust zero adjustment (R10) until exactly zero volts are read out on M1.
- e) Open S1 and check the 5 volt reading. Repeat "C" and "D" as necessary to achieve the desired accuracy. FIG. 3-6 below shows graphically how the programming ratio can be precision adjusted.

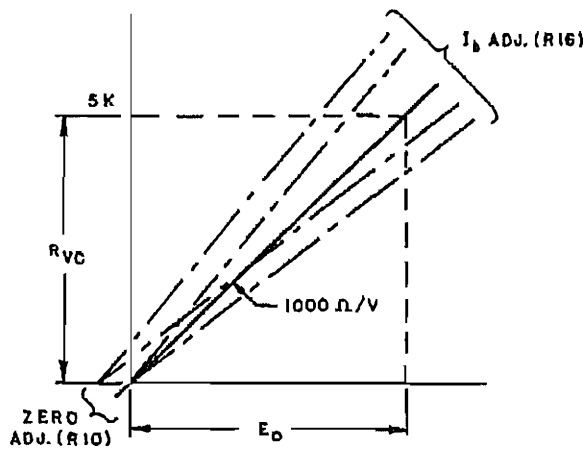

FIG. 3-6 ESTABLISHING PROGRAMMING LINEARITY.

3-16 PROGRAMMING OUTPUT VOLTAGE WITH RESISTANCE

3-17 The output voltage of the PAT power supply can be varied by means of a control resistance, connected between terminals (11) and (12) of the barrier-strip. This resistance may be fixed, continuously adjustable, or stepped, or it may be a combination of these. When fixed resistors are switched as the voltage control resistance, the switching device must have "make before break" contacts in order that the control circuit does not open during transfer. While the steady state current through R_{vc} is only 1 mA, it will rise to considerably higher peak values when larger voltage steps are programmed. The programming resistors must absorb these peak currents which consist of energy stored in the output capacitor. Consequently, it is recommended that the dissipation rating of these programming resistors is made several times the steady state power dissipated in them.

The value of the output voltage is given by equation (1)

$$E_o = R_{vc} \left(\frac{E_r}{R_r} \right)$$

Since $\frac{E_r}{R_r} = I_b$ (2), it follows that $E_o = I_b R_{vc}$ (3).

Referring to equation (3), we see that since I_b is 1 mA in the PAT supplies (and can be precisely adjusted as shown in par. 3-11), for every volt of output, 1000 ohms control resistance must be provided. This corresponds to a "programming ratio" of 1000 ohms per volts.

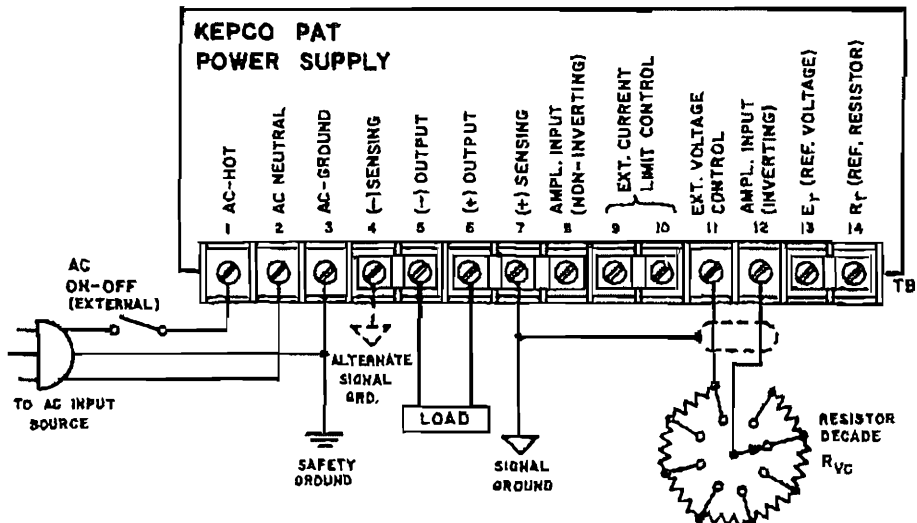

- NOTES:
- 1) The jumper links on TB1 must be securely connected as shown in the figure.
 - 2) Connect load and external R_{vc} as shown before applying a-c input.

ATTENTION!
A FOLD-OUT DIAGRAM IS PROVIDED AT THE END OF SECTION III (FIG. 3-16), RELATING THE BARRIER-STRIP CONNECTIONS TO THE CIRCUITRY OF THE PAT POWER SUPPLY.

FIG. 3-7 CONNECTION FOR RESISTANCE PROGRAMMING.

3-18 PROCEDURE (Refer to FIG. 3-7.)

- a) Determine value of programming resistor(s) for output voltage desired.
- b) Using 2-wire, shielded cable, connect the chosen resistors to terminals (11) and (12). Connect the shield to the system ground point.
- c) The output voltage will vary from zero to (1 mA) X (R_{vc}) as R_{vc} is adjusted from zero to its maximum value.

3-19 CURRENT STABILIZED OPERATION

3-20 In the current stabilized operating mode, the voltage comparison bridge is interconnected with an external current sensing resistor (R_s) and a current control (R_{cc}) as shown in FIG. 3-8 to maintain a constant voltage drop across R_s . In this way, an adjustable stabilized load current is obtained. Characteristic of the stabilized current supply is the ability to change its output voltage automatically in order to maintain a stabilized current through a range of possible load resistances. The range of output voltage that the supply can deliver and simultaneously maintain stabilized current is referred to as the COMPLIANCE VOLTAGE.

3-21 The current sensing resistor R_s is chosen to develop a 1 volt drop at the maximum desired current. It is calculated by dividing this current into 1 volt. The value of R_s is not critical and can be the nearest standard resistance available. Several facts should be kept in mind, however, when choosing R_s . A compromise must be made between a large and a small value. While a large value is desirable for good current regulation, it is less so in view of the power dissipated across it. It must be remembered that all the load current is flowing through R_s and the input to the regulator is connected across it. It is therefore vital that all extraneous changes across R_s ; i.e., resistance change due to temperature, are kept to a minimum. A high quality, low TC (20 ppm) resistor at least 10 times the actual wattage needed, is therefore strongly recommended.

3-22 The current control resistor is chosen on the basis of the control ratio of the Kepco comparison bridge, and V_s , the maximum voltage across R_s . If R_s was selected for 1 volt drop, then $V_s = 1$ volt and $R_{cc} = V_s$ times the control ratio or:

$$R_{cc} = 1 \text{ volt (1000 ohms/volt)} = 1000 \text{ ohms}$$

A high quality, low TC (20 ppm) resistor is recommended for R_{cc} .

3-23 PROCEDURE (Refer to FIG. 3-8.)

The actual setup procedure for current regulation is perhaps best shown by a practical example. A Model PAT 72-0.3 is to be set up for current stabilized output from 30 mA to 300 mA.

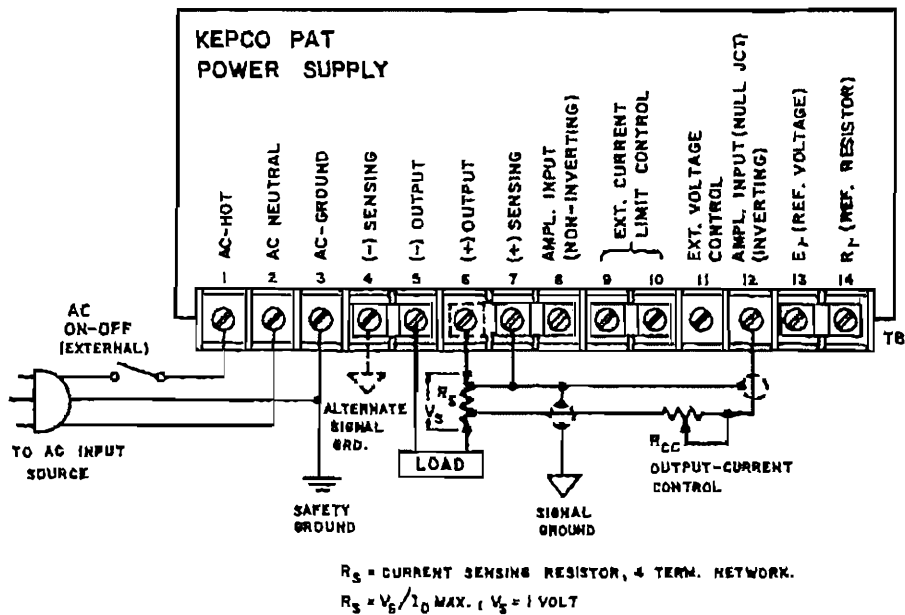

- NOTES:
- 1) The jumper links on TB1 must be securely connected as shown in the figure.
 - 2) Connect load and external R_{CC} as shown before applying a-c input.

ATTENTION!
A FOLD-OUT DIAGRAM IS PROVIDED AT THE END OF SECTION III (FIG. 3-16), RELATING THE BARRIER-STRIP CONNECTIONS TO THE CIRCUITRY OF THE PAT POWER SUPPLY.

FIG. 3-8 CONNECTIONS FOR STABILIZED CURRENT OPERATION.

a) R_S is chosen by:

$$R_S = \frac{1 \text{ volt}}{0.3A} = 3.33 \text{ ohms.}$$

$$P_{diss} = V_S I_{max.} = 1 \text{ volt } (0.3A) = 0.3 \text{ watts.}$$

Three 10 ohm, 1 W, wirewound resistors connected in parallel will be satisfactory.

b) The control resistance R_{CC} is found by calculating its limits:

$$R_{CC} (\text{max.}) = V_S (\text{max.}) \times \text{control ratio} = 1V \times \frac{1000 \text{ ohms}}{V} = 1000 \text{ ohms.}$$

$$R_{CC} (\text{min.}) = V_S (\text{min.}) \times \text{control ratio} = 0.1V \times \frac{1000 \text{ ohms}}{V} = 100 \text{ ohms.}$$

As R_{CC} is therefore varied from 100 ohms to 1000 ohms, the regulated current will vary from 30 to 300 mA, and the compliance voltage from approximately 0 to 71 volts.

c) Since, in the above example, the sensing voltage across R_S went below 1 volt at the low current output, the current regulation may not be satisfactory for the purpose intended. (Specifications are based on 1 volt sample.) To keep output effects within specifications, we must calculate R_S under minimum current conditions.

$$V_S \text{ min.} = 1 \text{ volt}$$

$$I_{\text{min.}} = 0.03A$$

$$R_S = \frac{1 \text{ volt}}{0.03A} = 33.3 \text{ ohms}$$

The actual power dissipation of R_S is given by

$$P_{DISS} = V_S (\text{max.}) \times I_O (\text{max.}) = 10V \times 0.3A = 3 \text{ watts}$$

(Three 100 ohm, 10 W, wirewound resistors connected in parallel will be satisfactory.)

R_{CC} will now be:

$$R_{CC} (\text{max.}) = V_S (\text{max.}) \times \text{control ratio} = 10V \times 1000 \text{ ohm/V} = 10 \text{ K ohms.}$$

$$R_{CC} (\text{min.}) = V_S (\text{min.}) \times \text{control ratio} = 1V \times 1000 \text{ ohm/V} = 1 \text{ K ohm.}$$

- d) In general, a new value for R_S should be calculated if the required output current range exceeds a 1:10 ratio. Below this range, performance will be adequate for most applications.

3-24 PROGRAMMING BY CONDUCTANCE

- 3-25 For special applications, the output voltage E_O can be adjusted by varying the bridge current. The relationship governing this type of programming is:

$$E_O = E_r (R_{VC}) (G),$$

$$\text{Where: } G = \frac{1}{R_r + R_x} = \text{programming conductance, or,}$$

$$E_O = \frac{E_r}{R_r + R_x} (R_{VC})$$

- E_O = Output voltage
- E_r = Reference voltage
- R_{VC} = Control resistance
- R_r = Reference resistance
- R_x = Programming resistor

Since $E_r/R_r = I_b$ and $E_O = I_b R_{VC}$, the output voltage varies directly as I_b changes. Changing I_b with the help of an additional resistor in series with R_r results in an inversely proportional change of I_b since now:

$$I_b = \frac{E_r}{R_r + R_x}$$

This method of output voltage adjustment is therefore referred to as *Conductance Programming*.

- 3-26 Conductance programming is a linear, but reciprocal function when analyzed in terms of resistance. It can, however, be very useful, especially over a limited range and for small changes in output voltage. Another distinct advantage of this type of programming is the "built-in" safety feature. Should the programming circuit open accidentally, the programming resistance becomes infinite, the conductance is zero, and consequently, the output voltage becomes zero.

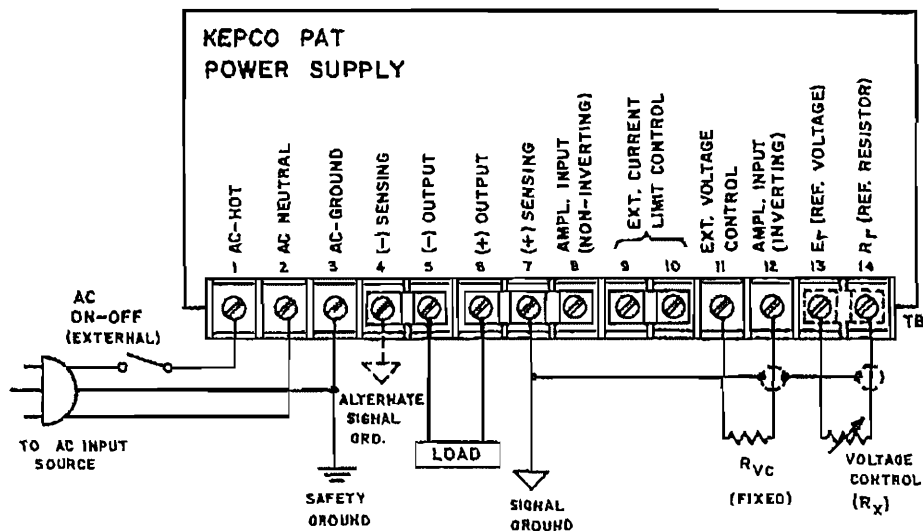

- NOTES:
- 1) The jumper links on TB1 must be securely connected as shown in the figure.
 - 2) Connect load and external R_{VC} as shown before applying a-c input.

ATTENTION!
A FOLD-OUT DIAGRAM IS PROVIDED AT THE END OF SECTION III (FIG. 3-16), RELATING THE BARRIER-STRIP CONNECTIONS TO THE CIRCUITRY OF THE PAT POWER SUPPLY.

FIG. 3-9 CONNECTIONS FOR CONDUCTANCE PROGRAMMING.

3-27 PROCEDURE (Refer to FIG. 3-9.)

Example E_O desired = 3 to 5 volts.

- a) Select R_{VC} for maximum desired output voltage E_O .

$$R_{VC} = \frac{E_O}{I_b}, R_{VC} = \frac{5V}{1 \text{ mA}} = 5 \text{ K ohms}$$

- b) A change of E_O to 3 volts requires a bridge current reduction of:

$$\Delta I_b = \frac{\Delta E_O}{R_{VC}} = \frac{2 \text{ volts}}{5 \text{ K ohms}} = 0.4 \text{ mA}$$

- c) Since the standard bridge current is:

$$I_b = \frac{E_r}{R_r} = 1 \text{ mA},$$

the additional resistance needed for the new bridge current " I_b " = 0.6 mA is:

$$I_b'(R_r + R_x) = E_r, R_x = \frac{E_r}{I_b} - R_r \text{ or } R_x = \frac{6 \text{ volts}}{0.6 \text{ mA}} - 6 \text{ K} = 4 \text{ K ohms.}$$

A 4 K ohm, WW, low TC potentiometer connected in series with the internal R_r (see FIG. 3-9) will change the output voltage from 3 to 5 volts when varied from 0 to 4 K ohms.

NOTE: A word of caution may be in order in regard to the changing of the bridge current. The 1 mA value has been selected for maximum stability in the zener reference circuit. A large departure from this value is not advisable. If a $\pm 50\%$ change in I_b is not sufficient to achieve the desired voltage swing, an external reference supply can be used.

3-28 PROGRAMMING OUTPUT VOLTAGE WITH EXTERNAL VOLTAGE

3-29 The output voltage (E_O) of the PAT power supply can be varied by means of another external voltage source. This external programming voltage supplies the control current (I_b) formerly delivered by the internal reference voltage of the PAT supply. The output voltage (E_O) "follows" the programming source and maintains a value that remains in a constant proportion to it. The relationship governing this type of programming can be expressed by the equation:

$$E_O = E_i \frac{R_{VC}}{R_i}$$

Where: E_O = Output voltage to be programmed.

E_i = Programming voltage (input).

R_{VC} = Voltage control resistance of the supply to be programmed.

(R_{VC} can be either internally or externally connected.)

R_i = External programming resistor (coupling resistor).

3-30 The values of the above quantities can be chosen to suit the particular application, although a few basic facts must be considered concerning their selection. E_O is, of course, limited by the maximum capability of the supply to be programmed. E_i can be any variable unipolar source having parameters at least as good as the desired E_O and being able to deliver the necessary I_b . The resistors R_i and R_{VC} are selected by first determining I_b , the desired bridge current.

Since I_b is supplied by E_i and also subtracts from the load current of the supply to be programmed, it should be kept as low as possible but not under 100 μA .

3-31 Once I_b is selected and E_i as well as the desired output voltage E_o are known, R_{VC} and R_i are calculated by these simple relations

$$R_{VC} = \frac{E_o}{I_b} \text{ (Eq. 2) where } I_b = \frac{E_i}{R_i} \text{ (4) and } E_o = \frac{E_i}{R_i} \times (R_{VC})$$

Stability, more than accuracy is the dominant criteria for selecting R_{VC} and R_i , since part of the resistance can be made adjustable to compensate for tolerances and offset voltages. Another important consideration in selecting control and programming resistors is to leave a wide safety margin when determining their wattage rating and to use only low temperature coefficient units.

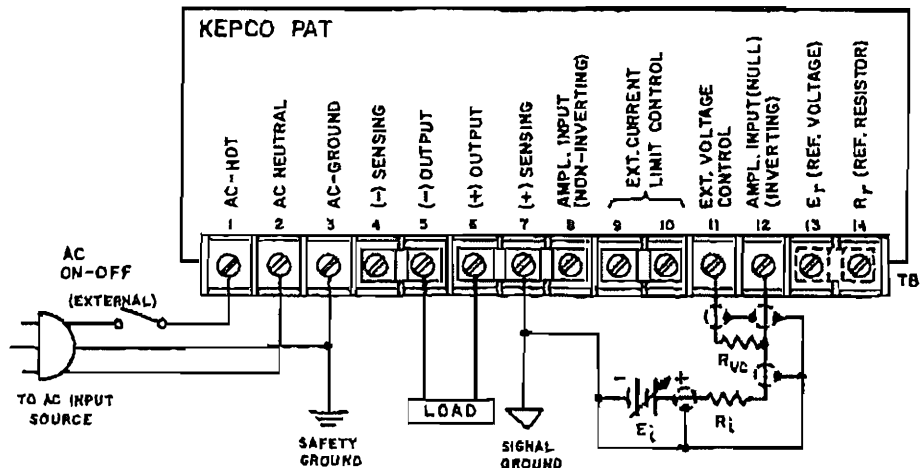

- NOTES:
- 1) The jumper links on TB1 must be securely connected as shown in the figure.
 - 2) Connect load and external R_{VC} as shown before applying a-c input.

ATTENTION!
A FOLD-OUT DIAGRAM IS PROVIDED AT THE END OF SECTION III (FIG. 3-16), RELATING THE BARRIER-STRIP CONNECTIONS TO THE CIRCUITRY OF THE PAT POWER SUPPLY.

FIG. 3-10 CONNECTIONS FOR VOLTAGE PROGRAMMING.

3-32 PROCEDURE (Refer to FIG. 3-10.)

- Connect components as shown in FIG. 3-10. Disconnect link between terminals (13) and (14) on the barrier-strip. Use shielded wire as indicated and connect shield to single system ground.
- Component selection may be shown best in the form of an example.

Example:

A Model PAT 40-0.5 is to be programmed from 0 to 30V.

The programming source available is a variable 10 volt source, capable of delivering 5 mA.

The bridge current (I_b) is selected to be 5 mA.

We find R_{VC} and R_i by using equations (3) and (4)

$$(3) R_{VC} = \frac{E_o}{I_b} = \frac{30V}{5 \text{ mA}} = 6 \text{ K} \quad (4) R_i = \frac{E_i}{I_b} = \frac{10V}{5 \text{ mA}} = 2 \text{ K}$$

Power dissipated in R_{VC} = 30V (0.005) = 0.15 W (use 1 W).

Power dissipated in R_i = 10V (0.005) = 0.05 W (use 0.5 W).

3-33 SERIES OPERATION OF PAT MODULES

3-34 GENERAL. Kepco PAT Modules can be series-connected for increased voltage output, provided the specified limits on voltage to chassis are not exceeded. When series-connected, the supplies should be protected by means of a semiconductor diode across the output terminals of each power supply, as shown in FIG. 3-11. The peak inverse rating of these diodes must be at least as large as the output voltage of the supply to which they are connected. The continuous current rating of the diodes should be at least as great as the largest short-circuit current of the interconnected supplies.

3-35 PROCEDURE

- Connect load as shown in FIG. 3-11. Keep voltage drop in load wires as low as practical by using heavy gauge wires.
- Connect protective diodes across respective output terminals.
- Remove jumpers as shown and connect error-sensing leads. Refer to par 3-4 for a description of the error sensing technique.
- Turn supplies "on" and adjust voltage on either control as required.

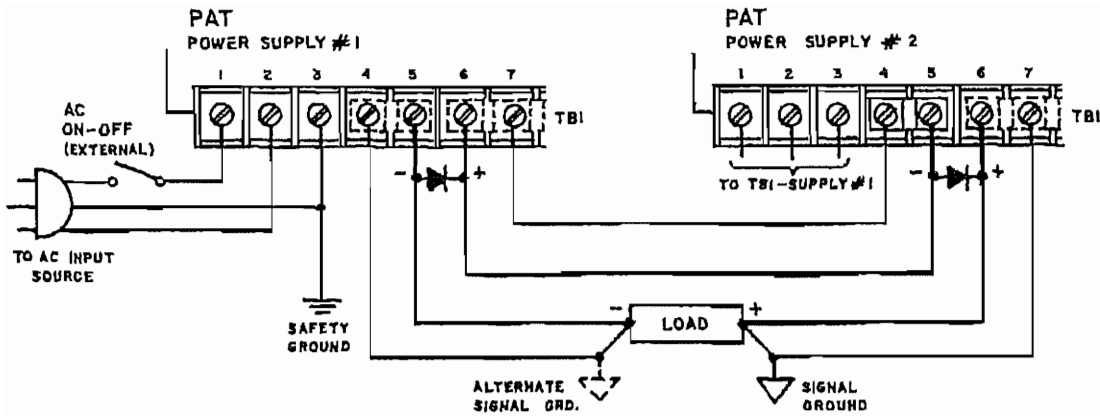

FIG. 3-11 SERIES CONNECTION OF PAT SUPPLIES.

3-36 PARALLEL OPERATION OF PAT MODULES

3-37 Two identical PAT power supplies may be operated in parallel for increased load-current output. Each supply is set approximately to the desired output voltage, with its respective current limiting adjustment at the factory-adjusted value (105% $I_{O \text{ max.}}$). After paralleling the two power supplies, one of them (supply #1) will inherently be at a slightly higher output voltage than the other (supply #2). Consequently, supply #1 will deliver all the load current up to the setting of its current limiting adjustment. As the load is increased beyond this limit of supply #1, supply #2 takes over and delivers the additional current. The current limiting adjustment of supply #1 can now be decreased so that approximately equal current sharing is obtained. FIG. 3-12 shows in form of a diagram how the two supplies operate in parallel with their respective current adjustments at the factory-adjusted value (105% $I_{O \text{ max.}}$). It will be obvious from the diagram that the areas of load regulation are within the output current bands of the individual supplies only. Therefore, output effects due to load changes cannot be measured from zero to twice the load current, for example, but only within the individual load current bands. Error sensing as described in paragraph 3-4 (from either supply) may be used if precise regulation at the load is required.

NOTE: When paralleling power supplies, care should be exercised to avoid turning the voltage control of *only one* supply close to zero. This precaution is necessary to prevent possibly damaging currents in the voltage control resistor as its limiting resistance is lowered.

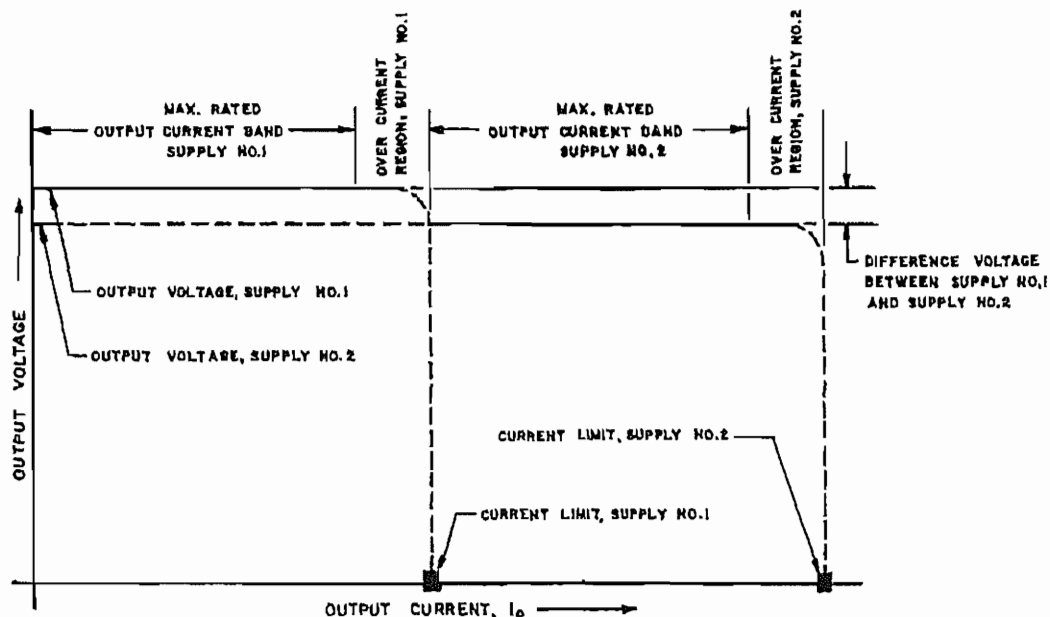

FIG. 3-12 PARALLEL OPERATION, PAT SUPPLIES.

3-38 PROCEDURE (Refer to FIG. 3-13.)

- a) Connect units as shown in FIG. 3-13. Open SW-1 and SW-2 and connect to line.
- b) Close SW-1 and adjust both units to the approximate output voltage desired.
- c) Close SW-2, Observe load current meters M1 and M2. Adjust Current Limit Adjust potentiometer R23 on the unit showing the higher current on its load current meter. Turn R23 counterclockwise until currents on M1 and M2 are approximately equal.

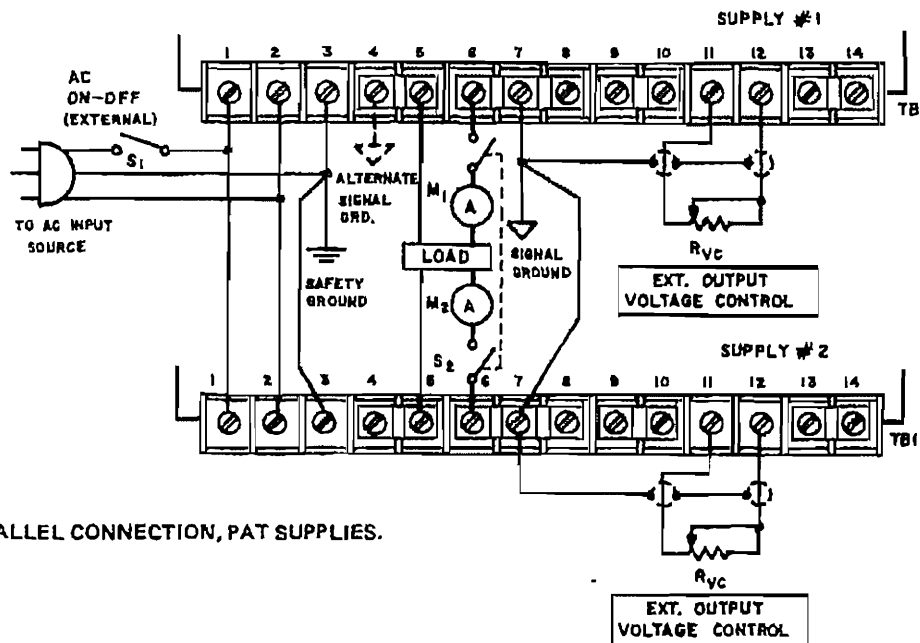

FIG. 3-13 PARALLEL CONNECTION, PAT SUPPLIES.

3-39 VOLTAGE PROGRAMMING WITH NONINVERTING INPUT

3-40 A useful property of a noninverting amplifier is the large input impedance developed by negative feedback. Noninverting input programming may therefore be used for applications where the source impedance is high and large control currents cannot be drawn from the programming source. Since the high input impedance of the noninverting configuration does not depend upon the magnitude of the feedback components, the latter may be selected quite low in a region of values where high quality, stable components are readily available. Their lower limit is, in fact, only given by the output capability of the operational power supply/amplifier. The common mode voltage limit must be observed for the amplifier used in the PAT power supplies (typically 8 volts) since excessive input voltages will saturate the amplifier. The approximate transfer function for noninverting operation may be expressed by:

$$E_o = E_i \left(\frac{R_{vc}}{R_i} + 1 \right)$$

For exact equations, limitations and compensation circuits, please refer to the standard literature for operational amplifiers. A simple example illustrating the use of the noninverting input is given below.

3-41 A Model PAT 40-0.5 is available to produce a 2:1 replica of a -5V reference source. Referring to the transfer function given above, we must have: $E_o = 2 E_i$; i.e., the ratio R_{vc}/R_i must equal unity or $R_{vc} = R_i$. If two 1 K ohm wirewound resistors are available, the output current loss of the PAT power supply due to the feedback current is negligible:

$$I_{\text{feedback}} = \frac{E_o}{R_{vc} + R_i} = \frac{10V}{1 K + 1 K} = 5 \text{ mA.}$$

No appreciable current is drawn from the reference source (except leakage current in the nanoampere range), but full load current (500-5 mA) can be drawn from the PAT 40-0.5 at twice the reference potential (2 X 5V = 10V).

An operational simplified schematic and the appropriate rear barrier-strip connections are shown in FIG. 3-14.

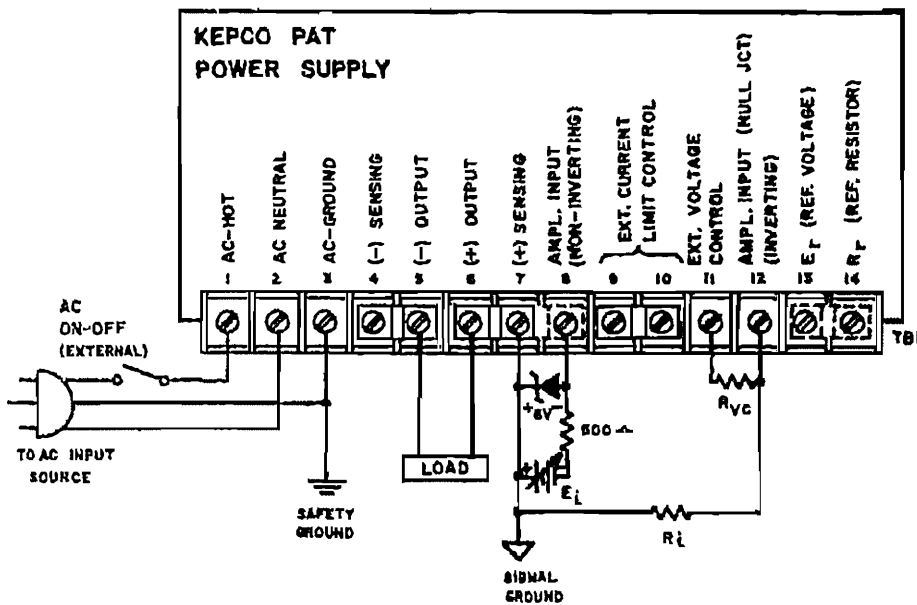

- NOTES:
- 1) The jumper links on TB1 must be securely connected as shown in the figure.
 - 2) Connect load and external R_{vc} as shown before applying a-c input.

ATTENTION!
A FOLD-OUT DIAGRAM IS PROVIDED AT THE END OF SECTION III (FIG. 3-16), RELATING THE BARRIER-STRIP CONNECTIONS TO THE CIRCUITRY OF THE PAT POWER SUPPLY.

FIG. 3-14 CONNECTIONS FOR VOLTAGE PROGRAMMING WITH NONINVERTING INPUT.

3-43 REMOTE CURRENT LIMITING

3-44 Barrier-strip terminals with a removable link [terminals (9)–(10)] have been provided on all PAT models, permitting the disabling of the internal limiting potentiometer and the connection of a remotely located, external control. Remote current limiting may be performed by substituting the internal component values and connecting them as shown in FIG. 3-15 below.

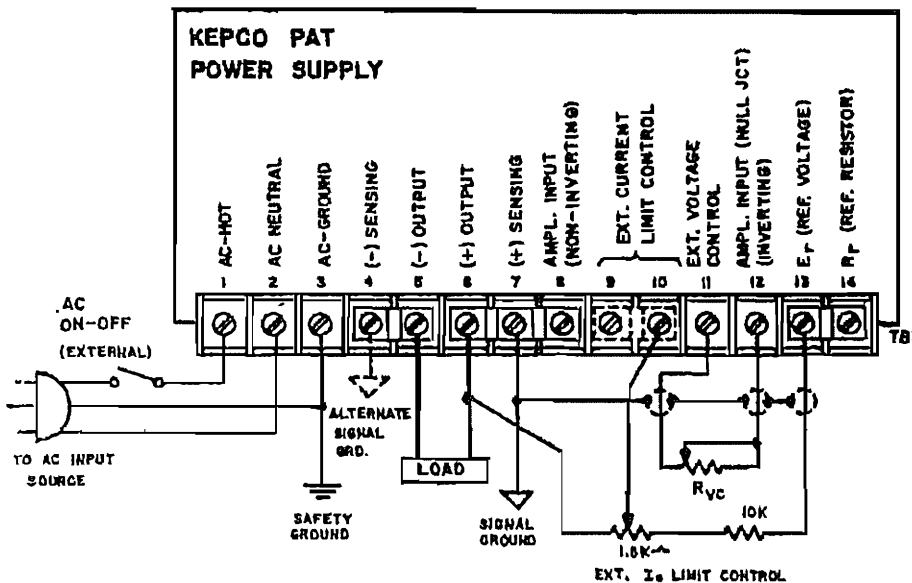

- NOTES:
- 1) The jumper links on TB1 must be securely connected as shown in the figure.
 - 2) Connect load and external R_{vc} as shown before applying a-c input.

ATTENTION!
A FOLD-OUT DIAGRAM IS PROVIDED AT THE END OF SECTION III (FIG. 3-16), RELATING THE BARRIER-STRIP CONNECTIONS TO THE CIRCUITRY OF THE PAT POWER SUPPLY.

FIG. 3-15 CONNECTIONS FOR REMOTE CURRENT LIMIT CONTROL.

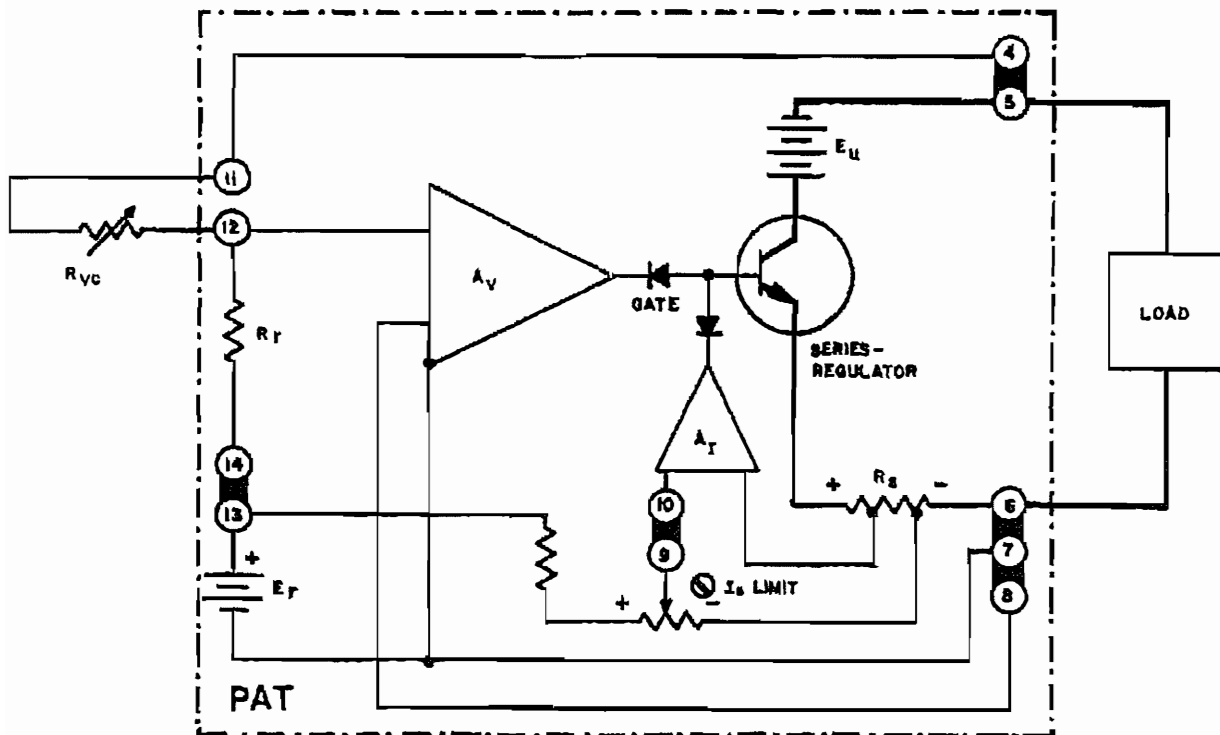

NOTES:

- 1) Numbers refer to the barrier-strip terminals on TB1.
- 2) Diagram shows PAT connected for standard operation without sensing at the load and the output controlled by external resistor (R_{VC}).
- 3) Remove jumper links (4-5) and (6-7) for remote sensing.

**FIG. 3-16 SIMPLIFIED CONNECTION DIAGRAM, KEPCO PAT MODELS.
(USE IN CONJUNCTION WITH BARRIER-STRIP DIAGRAMS IN SECTION III.)**

SECTION IV – THEORY OF OPERATION

(References in CAPITAL LETTERS refer to the nomenclature used in FIG. 4-1.)

4-1 SIMPLIFIED DIAGRAM DISCUSSION. (Refer to FIG. 4-1.)

- 4-2 The POWER TRANSFORMER converts the a-c source voltage to the required levels needed to produce the d-c operating voltages for the MAIN and AUXILIARY SUPPLIES. The MAIN POWER SUPPLY is in series with the PASS ELEMENTS and the CURRENT SENSING RESISTOR and produces the output voltage. The MAIN PASS ELEMENTS are controlling their series voltage drop in a way tending to keep the OUTPUT VOLTAGE constant. The necessary drive for this change is produced by the DRIVER CIRCUIT which in turn receives its command signals either from the CURRENT LIMIT AMPLIFIER or the ERROR SIGNAL AMPLIFIER.
- 4-3 The OUTPUT VOLTAGE is constantly compared to the REFERENCE SOURCE while the output current is monitored by the CURRENT SENSING RESISTOR. Any change in either output voltage or current is amplified by the associated amplifier and transferred to the GATE DIODES which feed directly into the DRIVER CIRCUIT which produces the needed drive signal for the MAIN PASS ELEMENTS thus either stabilizing the OUTPUT VOLTAGE, or, if the signal from the CURRENT LIMIT AMPLIFIER is dominant, limiting the output current to the preadjusted value.

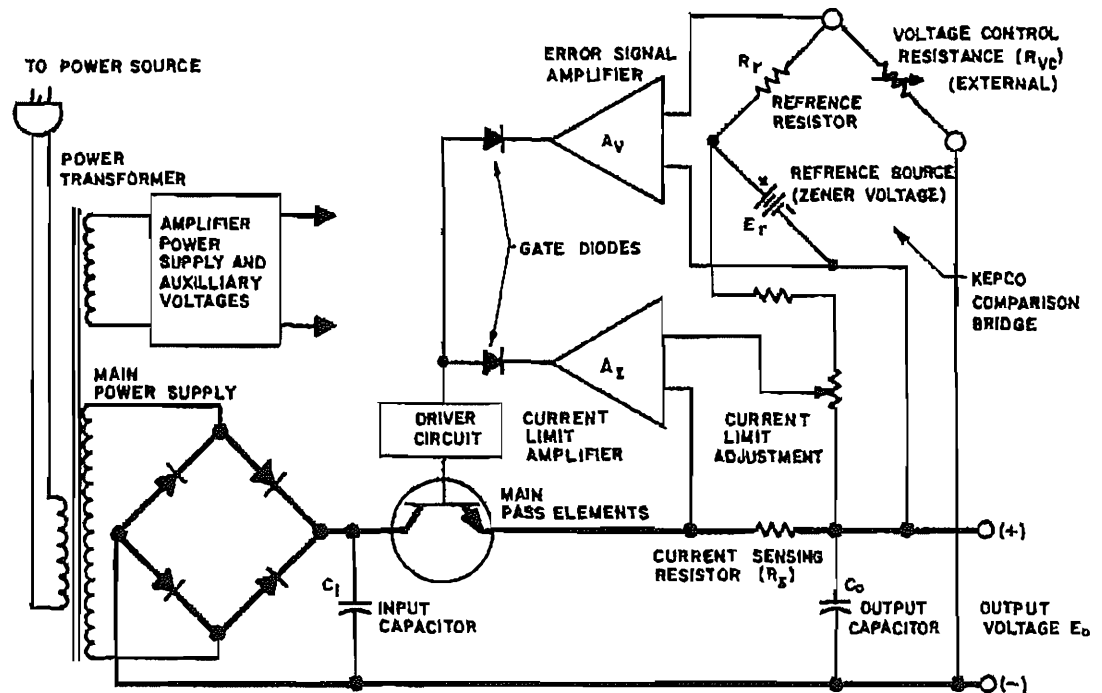

FIG. 4-1 SIMPLIFIED DIAGRAM, PAT POWER SUPPLIES.

4-4 CIRCUIT DESCRIPTION (Refer to Main Schematic, FIG. 6-1.)

- 4-5 For the purpose of analysis, the circuitry of the PAT power supply may be divided into several sections which are subsequently described below. Refer to the main schematic diagram, FIG. 6-3.
- a) A-C INPUT CIRCUIT. A-C input power is introduced through rear barrier-strip TB 1, terminals (1) and (2). Terminal (3) is connected to the chassis and should always be returned to a-c ground. The fuse (F 1) protects the primary of the power transformer (T201) from excessive current. T201 has two primary windings which are connected either in parallel (for 115V a-c service) or in series (for 230V a-c service).

- b) **MAIN D-C POWER SUPPLY.** The main d-c power is derived from a secondary winding on T201. Rectification and capacitive filtering are performed with silicon diodes CR15 through CR18 and C201. The main d-c power supply delivers the output current and the operating voltages for the series pass elements.
- c) **PASS ELEMENT CIRCUITRY.** The pass element (or series control transistor, Q201 – Q202) is connected in series with the plus (+) output terminal, the external load, and the unregulated raw d-c voltage from the main power supply. By changing the conductance of the pass element, the voltage drop across it is changed in such a way as to stabilize the output voltage across the external load. The base drive current needed to effect the pass element voltage drop is supplied by the driver stage (Q4) which in turn is driven by either the error signal amplifier (A_V) or the current limit amplifier (Q2, Q3). PAT power supplies above 0.5A output current have two pass transistors in parallel (Q201 and Q202).
- d) **THE ERROR SIGNAL AMPLIFIER (A_V).** This device is a d-c coupled, high-gain operational amplifier (plug-in). Its main function is to amplify the error signal derived from the comparison bridge to a level suitable to pass the gate circuit and drive Q4. Its inputs are brought out at the rear barrier-strip for programming the power supply output with input signals of either polarity.
- e) **THE COMPARISON BRIDGE.** This 4-arm electrical bridge circuit is the regulating and controlling element in many Kepco Power Supplies. In the PAT models it consists of the reference voltage E_r (CR8), the reference resistor R_r (R15 and the optional bridge current adjustment rheostat R16), the voltage control resistance R_{VC} [either the optional internal control R13 or the resistor externally applied between terminals (11)–(12) on TB1], and the output voltage E_o . As shown in FIG. 4-1, the internal reference voltage E_r in series with the reference resistance R_r is continuously compared with the output voltage E_o in series with the voltage control resistance R_{VC} . At balance ($E_{AA'} = 0$), a constant bridge current I_b flows through the bridge, keeping the error signal at bridge terminals A–A' at approximately zero volts. Any deviation in E_o caused by a-c source, load variations, or other influences will tend to change I_b in the bridge circuit and thereby produce an error signal at the bridge terminals A–A'. This error signal is then amplified by the error signal amplifier A_V and acts as a control signal for the series regulator or pass element changing the voltage drop across it in such a way as to restore the previous output voltage level.
- f) **THE CURRENT LIMIT CIRCUIT.** The differential inputs of the current limit amplifier (Q2, Q3) are connected to the current sensing resistor R_s (R26) and to a reference voltage. The voltage drop across R_s (due to load current flow) is continuously compared to the preset voltage at the current limit control (R19). As long as the voltage developed across R_s is less than the preset voltage level at R19, the current amplifier will be biased to its inactive state and will have no effect on the output. Both the current limit amplifier and error signal amplifier (A_V) are coupled through their respective gate diodes (CR9, CR10) to the driver transistor (Q4). The amplifier with the larger (negative) output will control the pass elements while the other amplifier is decoupled. Since the voltage drop across the sensing resistor (R26) is proportional to the output current, and the current limit control (R19) may be set to a voltage proportional to the desired output current, the current amplifier is inactive as long as the output current does not exceed the preset level. If the output current does increase, however, the current amplifier will produce an output signal more negative than A_V , thereby taking control away from the voltage amplifier A_V and limiting the output current sharply in the process.
- g) **AUXILIARY SUPPLIES**
AMPLIFIER POWER SUPPLY. This full-wave, capacitor-filtered source consists of a center-tapped winding on T201, silicon rectifiers CR1, CR2, and the filter capacitor C1. A current regulator stage (Q1) followed by a string of zener diodes (CR4, CR5, CR6, CR7) provides the operating voltages for the amplifiers and the comparison bridge circuit.
- h) **DRIVER COLLECTOR SUPPLY.** A half-wave, capacitor-filtered supply is derived from a winding on T201, rectified by silicon diode CR13 and filtered by C6. It delivers collector voltage to the driver transistor (Q4). R17 is a bleeder resistor, and CR14 is used to prevent latch-up under transient conditions.
- i) **I_{CBO} SUPPLY.** The operating voltages for the I_{CBO} circuitry are derived from the main power supply. Q5 is biased by the voltage drop across the series diodes (CR19, CR20) in such a way as to draw a relatively constant current, thus providing a current sink for the I_{CBO} of the pass elements. This ensures positive cutoff, especially at high operating temperatures.

SECTION V – MAINTENANCE

5-1 GENERAL

5-2 This section covers maintenance procedures, calibration, and test measurements of the Kepco Model PAT Power Supplies. Conservative rating of components and the noncongested layout should keep maintenance problems to a minimum. If trouble does develop, however, the removable wrap-around cover and the plug-in feature of the circuit boards provide exceptional accessibility to all components of the supply.

5-3 DISASSEMBLY (Refer to FIG. 5-1.)

5-4 The wrap-around cover may be easily removed by loosening the (5) holding screws (2 on each side and one on top). For component replacement, the printed circuit board assembly may be removed by loosening its (4) mounting screws and disconnecting the (2) mating connectors from the PCB assembly.

5-5 INTERNAL ADJUSTMENT PROCEDURES

5-6 CURRENT LIMITING CONTROL ADJUSTMENT (Refer to FIG. 5-2) A single-turn potentiometer (R19) conveniently located on the topside of the printed circuit board serves as an adjustment for limiting the output current through the range of 5% to 105% of its maximum rated value. It is factory-adjusted for approximately 5% above the maximum rated output current and has to be reset only if a component should have to be replaced or if a lower limit than the preset value is desired.

A convenient way to make the adjustment is as follows:

- a) Set up supply to draw the maximum desired output current and monitor the output with an oscilloscope having a vertical sensitivity of at least 0.1 mV/cm.
- b) If the desired current cannot be drawn, turn the current limit adjustment R19 slowly clockwise until the current, as read on an accurate ampere meter in series with the load, reaches the desired value. Continue the clockwise adjustment approximately 10° beyond this point.
- c) Observe ripple. Decrease the current limiting by slowly rotating R19 counterclockwise until output ripple increases substantially. Back off on R19 until output ripple appears normal again. Short circuit the power supply by connecting the d-c ampere meter across its output terminals. The short-circuit current will be approximately 5% of the maximum rated current above the set limit.

NOTE: A too-close setting of the current limit adjustment may result in premature limiting of the output current. It is therefore advisable to let the unit reach thermal equilibrium at its expected ambient temperature environment before the final adjustment is made.

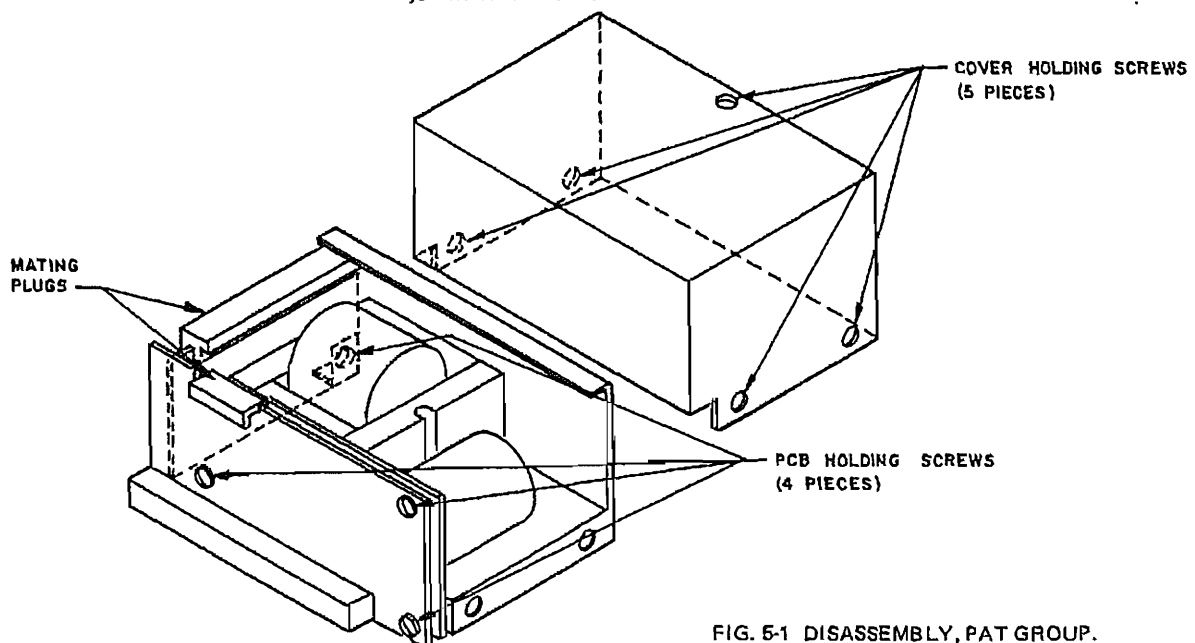

FIG. 5-1 DISASSEMBLY, PAT GROUP.

5-7 INSTALLATION AND ADJUSTMENT OF THE (OPTIONAL) VOLTAGE CONTROL RHEOSTAT (R_{vc}): REFER TO FIG. 5-2.

NOTE: Models which have this control factory-installed bear a 5 digit number following their model designation (e.g., "Model PAT 7-2-20000"). The installation notes may be disregarded with these units.

- a) Refer to FIG. 5-2. The voltage control resistance (R_{vc}) may be installed internally in the space on the printed circuit board as shown.
- b) The value choice of the voltage control resistance will depend on the application. For each 1000 ohms, 1 volt will be produced. Good quality metal film potentiometers should be selected. Refer to Amphenol Series 2600P or Bourns 3009P miniature trim potentiometers.
- c) After installation of the desired component, the power supply is adjusted to the chosen output voltage by varying R13 (and/or R16) and monitoring the output with a precision voltmeter.

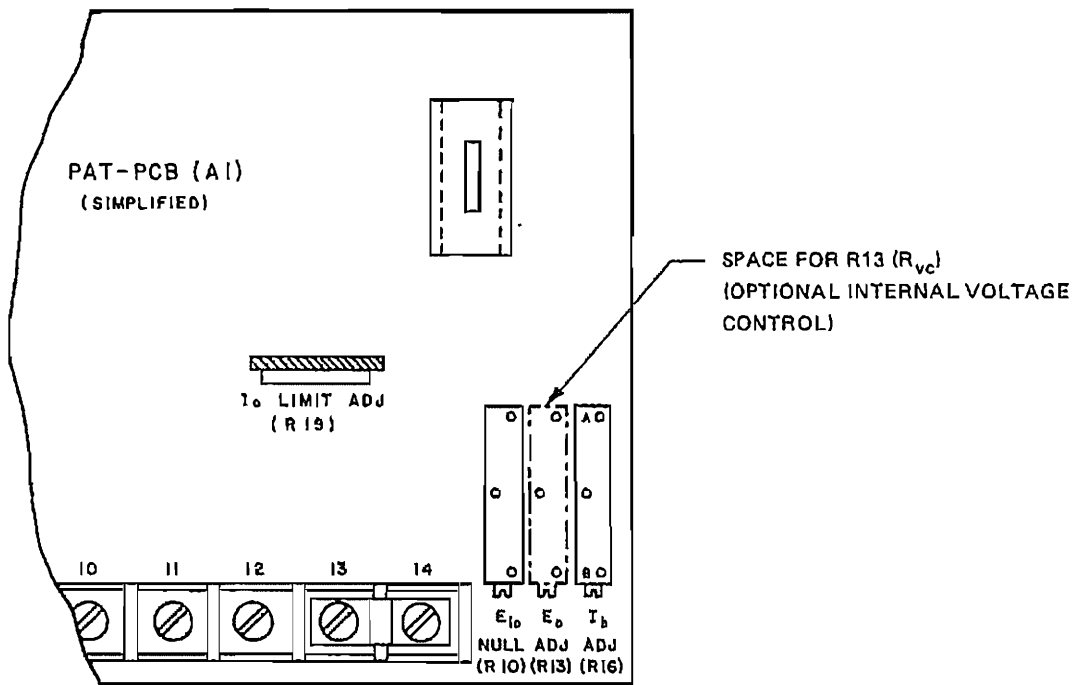

FIG. 5-2 INSTALLATION OF OPTIONAL CONTROLS.

5-8 TROUBLE SHOOTING

- 5-9 Modern, high performance power supplies have reached a state of sophistication that requires thorough understanding of the problems involved in repairing complex, solid-state circuitry. Servicing beyond simple parts replacements should consequently be attempted only by personnel thoroughly familiar with solid-state component techniques and with experience in closed-loop circuitry.
- 5-10 Trouble shooting charts showing resistance and voltage readings are of very limited usefulness with feedback amplifiers and are not included here. Instead, a detailed circuit description (Section IV), parts location diagrams, simplified functional schematics, and a main schematic with all significant voltage reading are presented.
- 5-11 The following basic steps in a case of power supply malfunctioning may also be found useful:
- a) If power supply does not function at all, check all power source connections and make certain power supply is connected to the correct source voltage. It is normally delivered for 115V a-c operation.
 - b) If supply is used as an operational amplifier with external feedback componets, disconnect all external components and reconnect internal reference and the voltage control. The following paragraphs refer to the instrument as a power supply, rather than an amplifier in order to simplify test setups and measurements.
 - c) If the power supply is basically functioning, but poor performance is evident, inspect the test setup to make certain the source of the trouble is not external.
 - d) Excessive output variations in any of the operating modes are usually traceable to incorrectly connected loads or faulty measurement techniques. Perform measurements are described in paragraph 5-13 and follow the connecting diagram.
 - e) Oscillation of the output voltage or output current is often due to a load with a large inductive component. Twisted load wires of sufficient diameter and held as short as practical are often the solution to the problem.
- 5-12 Kepco Field Engineering Offices or the Kepco Repair Department will be available for consultation or direct help in difficult service or application problems.

5-13 POWER SUPPLY MEASUREMENTS

- 5-14 Measurement of the significant parameters of a power supply is a requirement for incoming inspection, periodic maintenance, or after component replacement. Since the measurements require special techniques to insure correct results, suggestions for their performance are given below:
- a) Required Instrumentation:
 - 1) Constant a-c source voltage with provisions for "stepping" the voltage over a specified region (105–125V); a variable autotransformer is generally adequate if it is rated to deliver the input current of the unit under test.
 - 2) Resistive load, variable, with ON/OFF and shorting switch and capable of dissipating the full output power of the unit under test.
 - 3) D-C voltage monitor, differential voltmeter or power supply analyzer.
 - 4) Current sensing resistor for measurements of output effects in the current mode, 4-terminal device.
 - 5) A-C ripple monitor, sensitivity better than 1 mV. Ballantine Model 302C or Hewlett Packard Model 400H.
 - 6) Optional: Oscilloscope, vertical sensitivity better than 0.1 mV/cm.

- b) The 4-terminal network is an essential device for precise measurement of regulation. It can be approximated by the method shown in FIG. 5-4.

FIG. 5-3 shows the proper location of instrument leads when measuring output effects. The principle governing this method of measurement is simply *not* to measure any voltage drops due to load current flow. This can only be avoided by measuring output effects either directly at the sensing leads or by the use of the 4-terminal network.

- c) Output effects due to source or load variations in the voltage mode are defined as the amount of output voltage change resulting from a specified change of source voltage or from a change in load resistance. The output effects can be expressed as an absolute change (ΔE_o) or as a percentage in reference to the total output voltage E_o .

$$\% \text{ Output Effect} = \Delta E_o / E_o \times 100\%$$

- d) Output effects due to source or load variations in the current mode are defined as the amount of output current change resulting from a specified change in source voltage or from a change in load resistance. The output effects can be expressed as an absolute change (ΔI_o) or as a percentage in reference to the total output current I_o .

$$\% \text{ Output Effect} = \Delta I_o / I_o \times 100\%, \text{ where } \Delta I_o = V_{RM} / R_M$$

- e) Ripple: RMS ripple may be monitored on a true RMS reading instrument connected parallel to the instrument measuring the output effects. Careful wire dressing and shielding, as well as good a-c grounding, are of the utmost importance if valid measurements are being expected. An oscilloscope may also be used for p-p reading of the oscilloscope if the reading is divided by three.

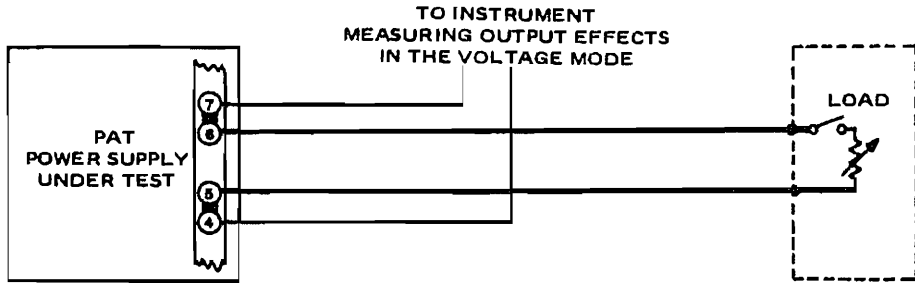

A) OUTPUT EFFECT MEASUREMENT (VOLTAGE) WITHOUT ERROR SENSING AT THE LOAD.

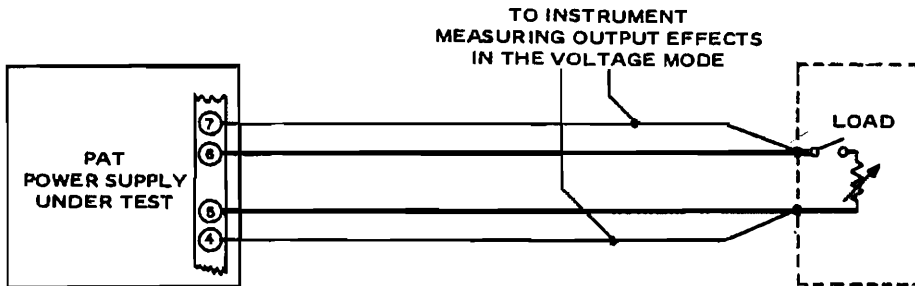

B) OUTPUT EFFECT MEASUREMENT (VOLTAGE) WITH ERROR SENSING AT THE LOAD.

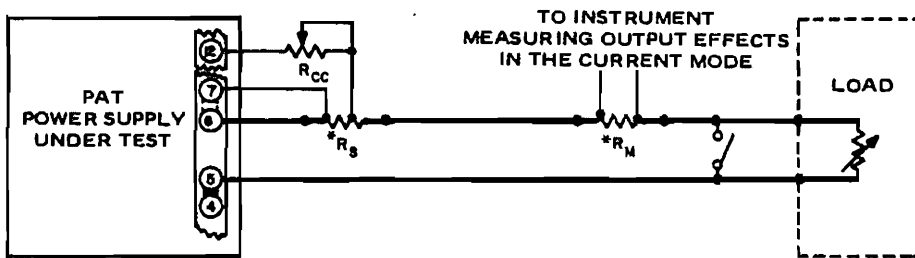

C) OUTPUT EFFECT MEASUREMENT (CURRENT).

* R_S and R_M should be selected such that their wattage rating is at least 10 times the actual power dissipated. All output effects depend on the stability of R_S and R_M . Recommended T.C. is 20 ppm. In addition, R_S and R_M must be of the "four terminal network" type.

FIG. 5-3 POWER SUPPLY MEASUREMENTS, CONNECTING METHODS.

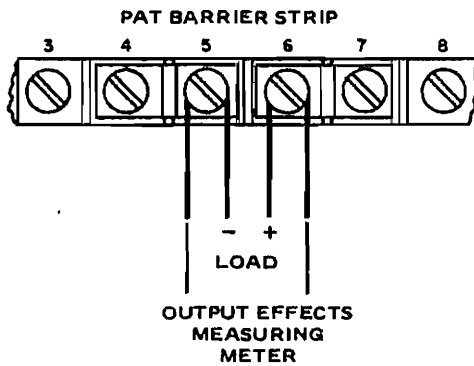

FIG. 5-4 APPROXIMATION OF A 4-TERMINAL NETWORK.

SECTION VI – ELECTRICAL PARTS LIST AND DIAGRAMS

6-1 GENERAL

6-2 This section contains the main schematic, the parts location diagrams, and a list of all replaceable electrical parts. All components are listed in alpha-numerical order of their reference designations. Consult your Kepco Representative for replacement of parts not listed here.

6-3 ORDERING INFORMATION

6-4 To order a replacement part or to inquire about parts not listed in the parts list, address order or inquiry either to your authorized Kepco Sales Representative or to:

KEPCO, INC.
131-38 Sanford Avenue
Flushing, N.Y. 11352

6-5 Specify the following information for each part:

- a) Model and complete serial number of instrument.
- b) Kepco part number.
- c) Circuit reference designator.
- d) Description.

6-6 To order a part not listed in the parts list, give a complete description and include its function and location.

NOTE: KEPCO DOES NOT STOCK OR SELL COMPLETE POWER SUPPLY SUBASSEMBLIES AS DESCRIBED HERE AND ELSEWHERE IN THIS INSTRUCTION MANUAL. SOME OF THE REASONS ARE LISTED BELOW:

- 1) Replacement of a complete subassembly is a comparatively rare necessity.
- 2) Kepco's subassemblies are readily serviceable, since most of them are of the "plug-in" type.
- 3) All active components are socket mounted, making replacement extremely easy.
- 4) The nature of a closed-loop power supply system requires that subassembly replacement is followed by careful measurement of the total power supply performance. In addition, depending on the function of the subassembly, extensive alignment may be required to restore power supply performance to specified values.

IF REPAIRS INVOLVING SUBASSEMBLY REPLACEMENTS ARE REQUIRED, PLEASE CONSULT YOUR LOCAL KEPCO REPRESENTATIVE OR THE KEPCO SALES ENGINEERING DEPARTMENT IN FLUSHING, NEW YORK, N.Y.

ABBREVIATIONS USED IN KEPKO PARTS LISTS

A) Reference Designators:

A	=	Assembly	L	=	Inductor
B	=	Blower (Fan)	LC	=	Light-Coupled Device
C	=	Capacitor	M	=	Meter
CB	=	Circuit Breaker	P	=	Plug
CR	=	Diode	Q	=	Transistor
DS	=	Device, Signaling (Lamp)	R	=	Resistor
F	=	Fuse	S	=	Switch
FX	=	Fuse Holder	T	=	Transformer
IC	=	Integrated Circuit	TB	=	Terminal Block
J	=	Jack	V	=	Vacuum Tube
K	=	Relay	X	=	Socket

B) Descriptive Abbreviations

A	=	Ampere	MET	=	Metal
a-c	=	Alternating Current	n	=	Nano (10^{-9})
AMP	=	Amplifier	NC	=	Normally Closed
AX	=	Axial	NO	=	Normally Open
CAP	=	Capacitor	p	=	Pico (10^{-12})
CER	=	Ceramic	PC	=	Printed Circuit
CT	=	Center-Tap	POT	=	Potentiometer
°C	=	Degree Centigrade	PIV	=	Peak Inverse Voltage
d-c	=	Direct Current	p-p	=	Peak to Peak
DPDT	=	Double Pole, Double Throw	ppm	=	Parts Per Million
DPST	=	Double Pole, Single Throw	PWR	=	Power
ELECT	=	Electrolytic	RAD	=	Radial
F	=	Farad	RECT	=	Rectifier
FILM	=	Polyester Film	RECY	=	Recovery
FLAM	=	Flammable	REG	=	Regulated
FP	=	Flame-Proof	RES	=	Resistor
°F	=	Degree Fahrenheit	RMS	=	Root Mean Square
FXD	=	Fixed	Si	=	Silicon
Ge	=	Germanium	S-End	=	Single Ended
H	=	Henry	SPDT	=	Single Pole, Double Throw
Hz	=	Hertz	SPST	=	Single Pole, Single Throw
IC	=	Integrated Circuit	Stud Mt.	=	Stud Mounted
K	=	Kilo (10^3)	TAN	=	Tantalum
m	=	Milli (10^{-3})	TSTR	=	Transistor
M	=	Mega (10^6)	u	=	Micro (μ) (10^{-6})
MFR	=	Manufacturer	V	=	Volt
			W	=	Watt
			WW	=	Wire Wound



KEPCO. REPLACEMENT PARTS LIST

Code 09-0380

PAT GROUP CIRCUIT BOARD ASSEMBLY (A1)

COMMON PARTS LIST

REFERENCE DESIGNATION	QTY.	DESCRIPTION	MFRS. NAME & PART NO. SEE BOTTOM NOTE	KEPCO PART NO.	REC. SPARE PART QTY.
A _v	1	Integrated Circuit Amplifier 8 Pin Dip (741 Type)	Kepeco Inc. 250-0025	250-0025	1
C1	1	Cap., Elect., Axial Leads 75uF, +75, -10%, 50V	Sprague Type 30D	117-0646	1
C2	1	Cap., Mylar, Axial Leads 0.0047uF, 20%, 200V	Wesco Type 32M	117-0588	1
C4	1	Cap., Mylar, Axial Leads 0.2uF, 10%, 200V	TRW Type X663F	117-0236	1
C6	1	Cap., Elect., Axial Leads 290uF, +75, -10%, 12V	Sprague Type 30D	117-0647	1
C7,10	2	Cap., Elect., Axial Leads 150uF, +75, -10%, 3V	General Electric Type 76F	117-0512	1
C9	1	Cap., Mylar, Axial Leads 0.1uF, 20%, 600V	TRW Type X663F	117-0316	1
C11	1	Cap., Ceramic, Disc 0.005uF, 10%, 500V	RMC Type SM	117-0061	1
CR3,4,5, 6,7	5	Zener Diode, Axial Leads 6.5V, 5%, 250mW	Transitron 1N763-1	121-0028	1
CR8	1	Zener Diode, Axial Leads (Ref) 5.9 to 6.5V, 400mW	International Rectifier Corp. 1N821	121-0041	1
CR22,23	2	Rectifier, Silicon, Axial Leads 100V (PIV), 5uA @ 0.5VF max.	Semicon Corp. Type HVP	124-0178	1
F1	1	Fuse, Fast Acting 1.0 Amp	Bussman Type AGX-1	141-0072	5
Q1	1	Transistor, Si, NPN Small Power, TO-5	Motorola 2N3053	119-0059	1
Q2,3	2	Transistor, Si, NPN, Plastic Small Signal, TO-18	Texas Instruments 2N5450	119-0093	1
R2	1	Resistor, Fixed, M. G. 82K ohm, 5%, 1/4W	TRW Type RG-1/4	115-2012	1
R3	1	Resistor, Fixed, Molded 3.9K ohm, 5%, 1/2W	Allen Bradley EB3925	115-0808	1
R5	1	Resistor, Fixed, Precision, M.F. 750 ohm, 1%, 1/4W	Dale Type MFF-1/4	115-2259	1
R6	1	Resistor, Fixed, Molded 47K ohm, 10%, 1/4W	TRW Type GBT-1/4	115-2237	1
R7	1	Resistor, Fixed, M. G. 6.2K ohm, 5%, 1/4W	TRW Type GBT-1/4	115-2258	1
R8	1	Resistor, Fixed, Molded 10K ohm, 10%, 1/4W	TRW Type GBT-1/4	115-2211	1
R9	1	Res., Fixed, Molded 150 ohm, 10%, 1/4W	TRW Type GBT-1/4	115-0543	1
R10	1	Resistor, Variable, Cermet 10K ohm, 10%, 3/4W	Bourns Type 3009P	115-2481	1

NOTE: REPLACEMENT PARTS MAY BE ORDERED FROM KEPCO, INC. ORDERS SHOULD INCLUDE KEPCO PART NUMBER AND DESCRIPTION.

PLEASE NOTE: THE MANUFACTURER'S NAME AND PART NUMBER LISTED FOR EACH ITEM ON REPLACEMENT PARTS LISTS REPRESENTS AT LEAST ONE SOURCE FOR THAT ITEM AND IS LISTED SOLELY FOR THE CONVENIENCE OF KEPCO EQUIPMENT OWNERS IN OBTAINING REPLACEMENT PARTS LOCALLY. WE RESERVE THE RIGHT TO USE EQUIVALENT ITEMS FROM ALTERNATE SOURCES.	KEPCO, INC.
---	-------------



KEPCO. REPLACEMENT PARTS LIST

Code 09-0380

PAT GROUP CIRCUIT BOARD ASSEMBLY (A1)

COMMON PARTS LIST

REFERENCE DESIGNATION	QTY.	DESCRIPTION	MFRS. NAME & PART NO. SEE BOTTOM NOTE	KEPCO PART NO.	REC. SPARE PART QTY.
R11	1	Resistor, Fixed, Molded 1.5K ohm, 10%, 1/4W	TRW Type GBT-1/4	115-2229	1
R12,17	2	Resistor, Fixed, Molded 560 ohm, 10%, 1/4W	TRW Type GBT-1/4	115-2210	1
R15	1	Resistor, Fixed, Precision, WW 5.7K ohm, 1%, 1W	Tepro Type TS-1W	115-1301	1
R16	1	Resistor, Variable, WW 1K ohm, 10%, 1W	Bourns Type 3007P	115-2264	1
R18	1	Resistor, Fixed, Precision, M.F. 10K ohm, 1%, 1/4W	Dale Type MFF-1/4	115-2174	1
R19	1	Resistor, Variable, Composition 1.5K ohm, 30%, 1/8W	C.T.S. Type X201	115-1939	1
R28	1	Resistor, Fixed, Molded 10 ohm, 10%, 1/4W	TRW Type GBT-1/4	115-2230	1

MISCELLANEOUS PARTS :

NA	1	Barrier Strip		167-0469	
NA	1	Cabinet Cover		129-0130	
F1	1	Fuse for 230V operation		141-0070	
J201	1	PC Mating Connector		143-0215	

NOTE: REPLACEMENT PARTS MAY BE ORDERED FROM KEPCO, INC. ORDERS SHOULD INCLUDE KEPCO PART NUMBER AND DESCRIPTION.

PLEASE NOTE: THE MANUFACTURER'S NAME AND PART NUMBER LISTED FOR EACH ITEM ON REPLACEMENT PARTS LISTS REPRESENTS AT LEAST ONE SOURCE FOR THAT ITEM AND IS LISTED SOLELY FOR THE CONVENIENCE OF KEPCO EQUIPMENT OWNERS IN OBTAINING REPLACEMENT PARTS LOCALLY. WE RESERVE THE RIGHT TO USE EQUIVALENT ITEMS FROM ALTERNATE SOURCES.	KEPCO, INC.
---	-------------

6-5/

6-6



KEPCO. REPLACEMENT PARTS LIST

MODEL PAT 40-0.5

INDIVIDUAL PARTS LIST

Code 09-0480

REFERENCE DESIGNATION	QTY.	DESCRIPTION	MFRS. NAME & PART NO. SEE BOTTOM NOTE	KEPCO PART NO.	REC. SPARE PART QTY.
-----------------------	------	-------------	--	----------------	----------------------

MAIN CHASSIS ASSEMBLY (A2):

C201	1	Cap., Electrolytic, Can 1400 uF, +75, -10%, 75V d-c	Cornell Dubilier 500142U075AA2B	117-0723	1
Q201,202	2	Transistor, Si, NPN Power, TO-3	Westinghouse 2N3055	119-0061	1
T201	1	Transformer, Power	Kepeco Inc. 100-1929	100-1929	1

PRINTED CIRCUIT BOARD ASSEMBLY (A1):

C8	1	Cap., Elect., Axial Leads 220uF, ±20%, 100V	Nichicon TVX2A221MCA	117-0598	1
CR1,2,9 thru 21	15	Rectifier, Silicon, Axial Leads 100V (PIV), 1.5A	Semtech Corp. Type SE-1	124-0133	1
Q4	1	Transistor, Si, NPN Small Power, TO-5	Fairchild 119-0094	119-0094	1
Q5	1	Transistor, Si, NPN Small Power, TO-5	Motorola 2N3053	119-0059	1
R20	1	Resistor, Fixed, Power, Axial 5K ohm, 5%, 3W	Tepro Type TS-3W	115-1094	1
R21	1	Resistor, Fixed, Molded 39 ohm, 10%, 1/4W	TRW Type GBT-1/4	115-2501	1
R22,24,26	3	Resistor, Fixed, Power, Ax. Lds. 1 ohm, 3%, 3W	Tepro Type TS-3W	115-2218	1
R23	1	Resistor, Fixed, Molded 330 ohm, 10%, 1/4W	TRW Type GBT-1/4	115-2233	1
R25,27	2	Resistor, Fixed, Power, Axial 2K ohm, 5%, 3W	Tepro Type TS-3W	115-0747	1

NOTE: REPLACEMENT PARTS MAY BE ORDERED FROM KEPCO, INC. ORDERS SHOULD INCLUDE KEPCO PART NUMBER AND DESCRIPTION.

PLEASE NOTE: THE MANUFACTURER'S NAME AND PART NUMBER LISTED FOR EACH ITEM ON REPLACEMENT PARTS LISTS REPRESENTS AT LEAST ONE SOURCE FOR THAT ITEM AND IS LISTED SOLELY FOR THE CONVENIENCE OF KEPCO EQUIPMENT OWNERS IN OBTAINING REPLACEMENT PARTS LOCALLY. WE RESERVE THE RIGHT TO USE EQUIVALENT ITEMS FROM ALTERNATE SOURCES.	KEPCO, INC.
---	-------------

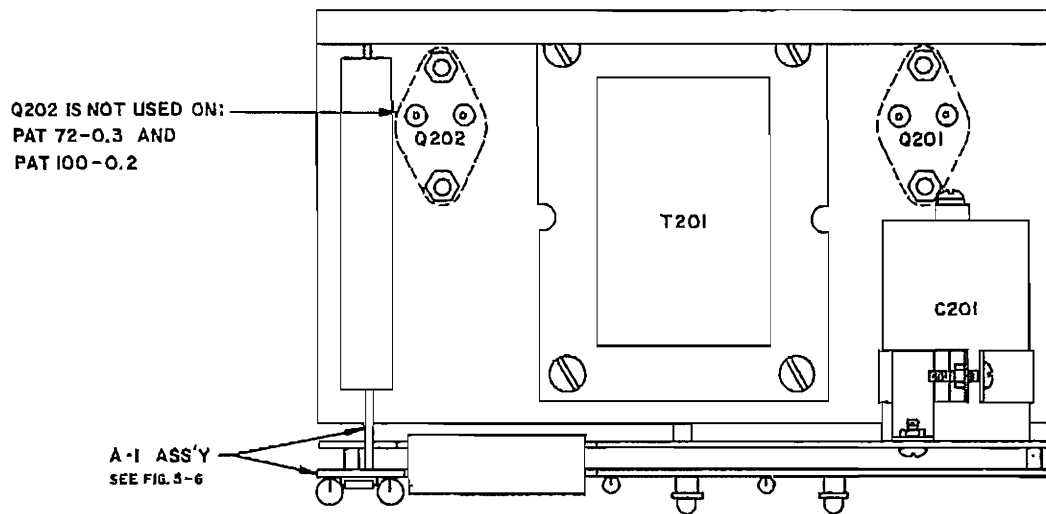
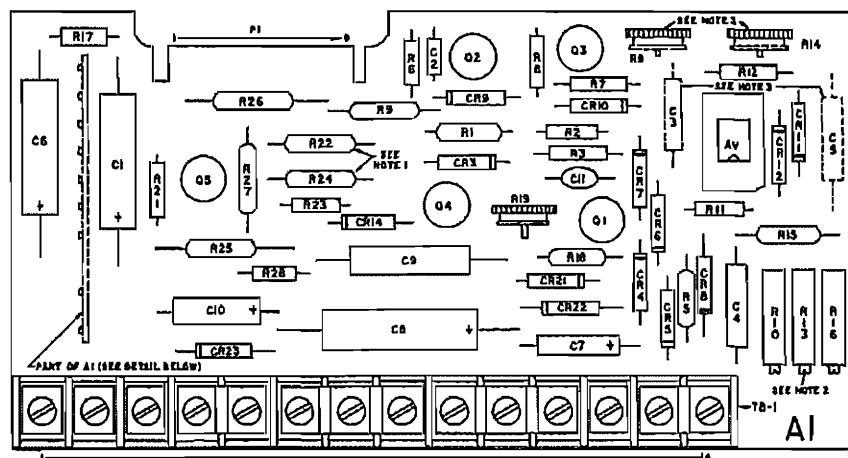

FIG. 6-1 COMPONENT LOCATION,
MAIN CHASSIS ASSEMBLY (A2).



NOTES:

1. R22 AND R24 ARE NOT USED ON PAT 72-0.3 AND PAT 100-0.2.
2. R13 IS USED ONLY IN MODELS WITH FIVE PLACE NUMERICAL SUFFIX.
3. C3, C5, R9 AND R14 ARE NOT USED IN ALL MODELS. REFER TO MAIN SCHEMATIC.

FIG. 6-2 COMPONENT LOCATION,
PRINTED CIRCUIT BOARD (A1).

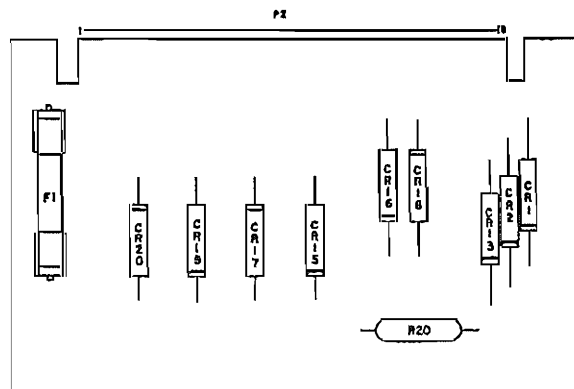

NOTE: CR16 THRU CR20 ARE MOUNTED ON LUGS
ON THE MODELS PAT 7-2, PAT15-L5 AND PAT21-1

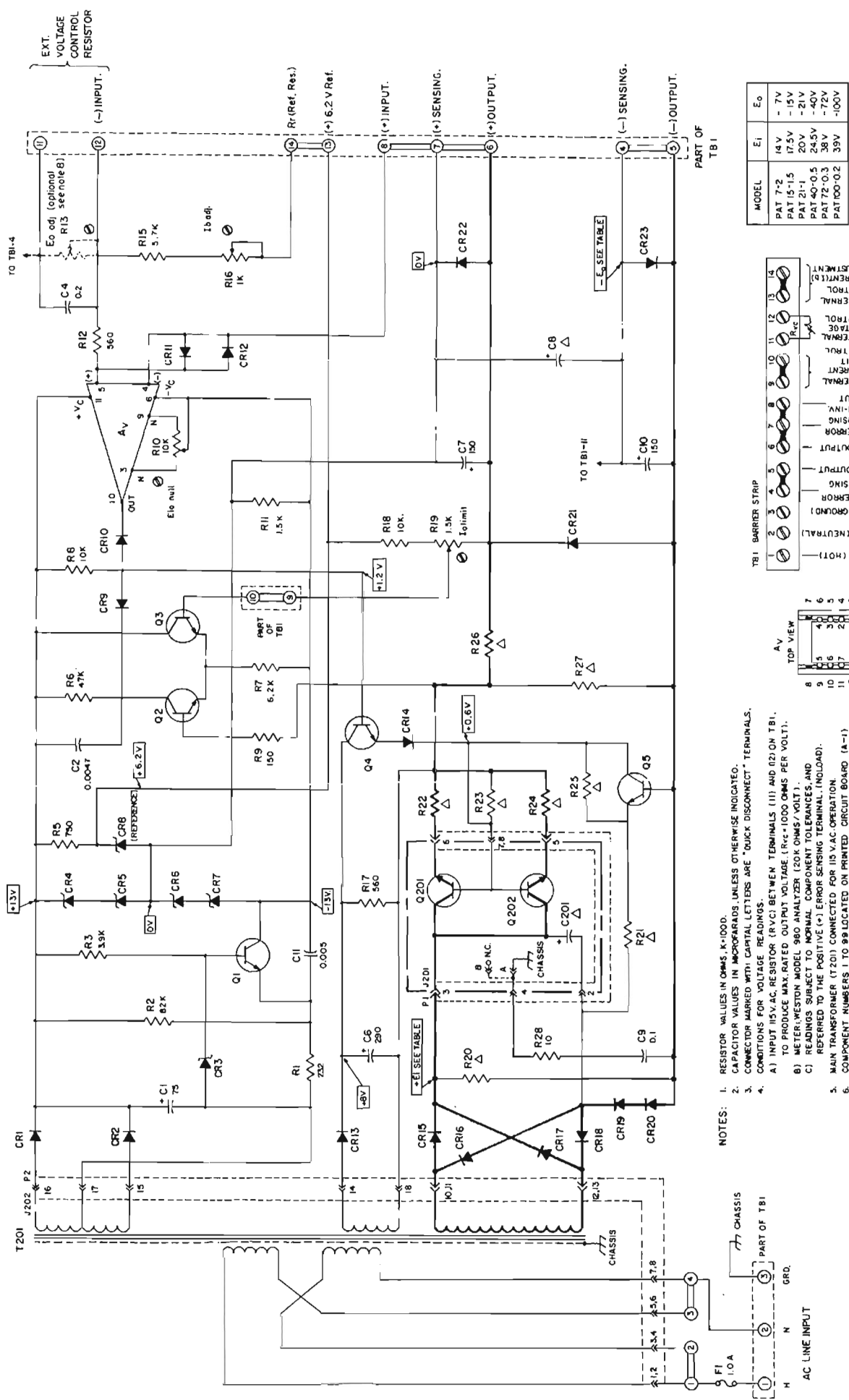

MODEL	E _i	E _o
PAT 7-2	14 V	- 7 V
PAT 15-1.5	17.5 V	- 15 V
PAT 21-1	20 V	- 21 V
PAT 40-0.5	24.5 V	- 40 V
PAT 72-0.3	38 V	- 72 V
PAT 100-0.2	39 V	- 100 V

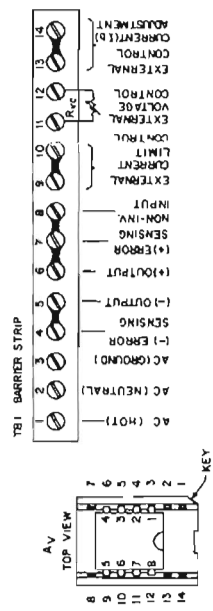

- NOTES:
- RESISTOR VALUES IN OHMS, K=1000.
 - CAPACITOR VALUES IN MICROFARADS UNLESS OTHERWISE INDICATED.
 - CONNECTOR MARKED WITH CAPITAL LETTERS ARE "QUICK DISCONNECT" TERMINALS.
 - CONDITIONS FOR VOLTAGE READINGS.
 - INPUT 115V AC RESISTOR (RVC) BETWEEN TERMINALS (11) AND (22) ON TBI.
 - METER/WESTON MODEL 960 ANALYZER (20K OHMS PER VOLT).
 - READINGS SUBJECT TO NORMAL COMPONENT TOLERANCES, AND REFERRED TO THE POSITIVE (+) ERROR SENSING TERMINAL, (INCLOAD).
 - MAIN TRANSFORMER (T201) CONNECTED FOR 115V AC OPERATION.
 - COMPONENT NUMBERS 201 TO 299 LOCATED ON MAIN CHASSIS (A-1).
 - COMPONENT NUMBERS 1 TO 99 LOCATED ON PRINTED CIRCUIT BOARD (A-2).
 - COMPONENTS MARKED * Δ - SEE PARTS LIST FOR VALUE.
 - VALUE OF R3 DEPENDING ON NUMERICAL SUFFIX TO PAT MODEL NUMBER.
 - Q202, R22, R23 NOT USED IN MODEL PAT100-0.2 AND MODEL PAT 72-0.3.

FIG. 6-3 MAIN SCHEMATIC, PAT SERIES.

EM15875/07-1080

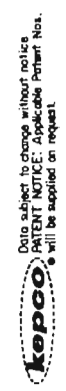



INSTRUCTION MANUAL CORRECTION

Please note the following corrections to the Manual Material as indicated:

Parts List and Schematic Diagram:

- | | | | | | |
|------------|---------------------------------------|-----------------------|-------------------|--|--|
| 1. CHANGE: | Barrier Strip | | | | |
| To: | Barrier Strip | | | | |
| | Beau 72514-C-53-V-J | | | | |
| | | | | | |
| 2. ERRATA: | ADD: R1 | Res.,Fxd.,Prec.,MF | 232 ohm,1/4W,1% | | |
| | (Page 6/3-6/4 Replacement Parts List) | | | | |
| | | | | | |
| 3. CHANGE: | C201 | Cap.,Electrolytic,Can | 950 μ F,75V | | |
| To: | C201 | Cap.,Electrolytic,Can | 1400 μ F,75V | | |
| | | | | | |
| 4. CHANGE: | R22,24,26 | Res.,Fxd.,Power,W.W. | 1 ohm,5%,3W | | |
| To: | R22,24,26 | Res.,Fxd.,Power,W.W. | 1 ohm,5%,3W | | |
| | | | | | |
| 5. CHANGE: | R19 | Res.,Fxd.. | 1.5K ohm,30%,0.1W | | |
| To: | R19 | Res.,Fxd.. | 2K ohm,30%,0.1W | | |
| | | | | | |
| 6. CHANGE: | R18 | Res.,Fxd.. | 10K ohm,1%,1/8W | | |
| To: | R18 | Res.,Fxd.. | 12.1K ohm,1%,1/8W | | |

PAT40-0.5/12-1484/r13	C5572
PAT40-0.5/02-1591/r13	Errata
PAT40-0.5/08-2896/r14	C7647
PAT40-0.5/08-0698/r14	BMC
PAT40-0.5/10-2506/r15	C10915

