

INSTRUCTION MANUAL

PRR 48-22M POWER SUPPLY

KEPCO INC.
An ISO 9001 Company.

MODEL PRR 48-22M POWER SUPPLY

ORDER NO.

REV. NO.

IMPORTANT NOTES:

- 1) This manual is valid for the following Model and associated serial numbers:

MODEL	SERIAL NO.	REV. NO.
-------	------------	----------
- 2) A Change Page may be included at the end of the manual. All applicable changes and revision number changes are documented with reference to the equipment serial numbers. Before using this Instruction Manual, check your equipment serial number to identify your model. If in doubt, contact your nearest Kepco Representative, or the Kepco Documentation Office in New York, (718) 461-7000, requesting the correct revision for your particular model and serial number.
- 3) The contents of this manual are protected by copyright. Reproduction of any part can be made only with the specific written permission of Kepco, Inc.

Data subject to change without notice.

©2000, KEPCO, INC.
P/N 243-0505



KEPCO, INC. • 131-38 SANFORD AVENUE • FLUSHING, NY. 11352 U.S.A. • TEL (718) 461-7000 • FAX (718) 767-1102
email: hq@kepcopower.com • World Wide Web: <http://www.kepcopower.com>

DESCRIPTION (Refer to FIG. 1)

The Kepco PRR group of power supplies are fixed d-c voltage sources delivering approximately 1000 Watts of output power. The design of the PRR supplies is based on Kepco's patented FLUX-O-TRAN[®] ferroresonant power transformer. PRR models can be operated either from domestic 120V a-c, 60 Hz power lines (models without suffix) or from foreign 230V a-c, 50 Hz sources (models with suffix "-50"). PRR power supplies are constructed in full-rack width and can be installed directly, or by means of slides, into standard (19-inch) equipment racks. PRR power sources are completely short-circuit proof, due to automatic current limiting of the ferroresonant power transformer at 125 to 150% of the rated output current.

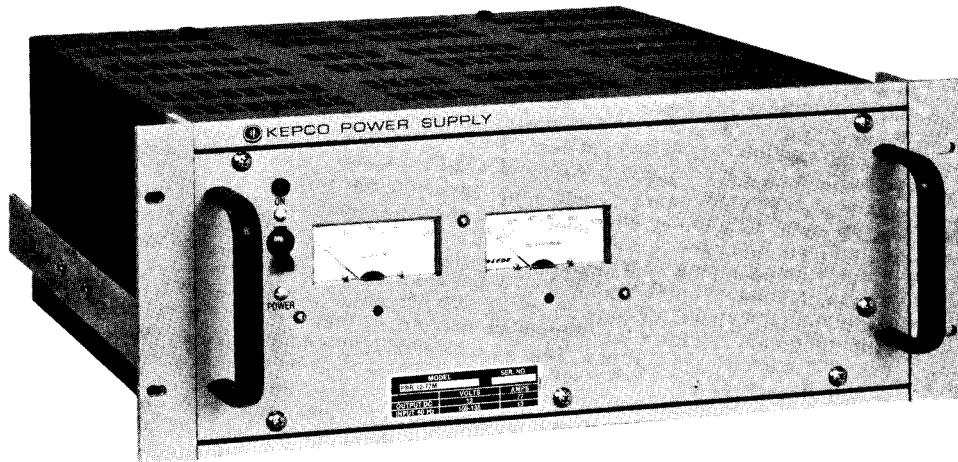

FIG. 1 KEPCO PRR POWER SUPPLY, FRONT VIEW.

SPECIFICATIONS, ELECTRICAL

A-C INPUT (PRR MODELS WITHOUT SUFFIX): 120V a-c, $\pm 15V$ a-c, 60 Hz $\pm 5\%$ ⁽¹⁾ single phase, 15A max.

A-C INPUT (PRR MODELS WITH SUFFIX "-50"): 230V a-c $\pm 30V$ a-c, 50 Hz $\pm 5\%$ ⁽¹⁾, single phase, 6A max.

⁽¹⁾ A 1% change in source frequency produces from 1 to 1.5% output voltage change.

D-C OUTPUT RANGE: See Table 1.

LOAD EFFECT: See Table 1 and applicable load effect curve in FIG. 2.

RIPPLE and NOISE: See Table 1 for maximum rms values and the graph in FIG. 3 for typical data.

SOURCE EFFECT: Less than $\pm 1\%$ (0.5% typical) of the rated output voltage for rated change in source voltage, with any load from 10-100% of the rated value.

OUTPUT VOLTAGE ACCURACY: Within $\pm 2\%$, or 0.25V, whichever is greater, of the specified output voltage, at nominal source voltage, 30°C ambient temperature, at maximum load and following a 30-minute warm-up period. Allow for an initial (cold) voltage approximately 1% higher than the specified output voltage accuracy. The output voltage increase at output current levels less than the maximum rated may be read from the load effect curves (FIG. 2) and must be added to the nominal output level.

OPERATING TEMPERATURE: -20°C to $+55^{\circ}\text{C}$.

STORAGE TEMPERATURE: -40°C to $+85^{\circ}\text{C}$.

TEMPERATURE EFFECT COEFFICIENT: Less than 0.05% output voltage change per $^{\circ}\text{C}$.

TIME EFFECT (8-hour drift): Less than 1% or 0.1 mV, whichever is greater, output voltage change.

MODEL	D-C OUTPUT		LOAD EFFECT (VOLTS INCREASE)		LOAD EFFECT CURVE	RIPPLE (max) RMS VOLTS	SHIP WGT.	
	VOLTS	AMPS	100%-50% LOAD	100%-25% LOAD			lbs.	kg.
PRR 12-77M	12	0-77	0.75	1.5	1	50mV	63	28.6
PRR 12-77M-50	12	0-62	0.75	1.5	1	50mV	63	28.6
PRR 24-42M	24	0-42	1.0	2.0	2	30mV	63	28.6
PRR 24-42M-50	24	0-34	1.0	2.0	2	30mV	63	28.6
PRR 28-36M	28	0-36	1.0	2.0	2	25mV	63	28.6
PRR 28-36M-50	28	0-29	1.0	2.0	2	25mV	63	28.6
PRR 48-22M	48	0-22	1.5	2.5	3	10mV	63	28.6
PRR 48-22M-50	48	0-18	1.5	2.5	3	10mV	63	28.6

Models with suffix "-50" operate from 50 Hz input sources
Models without this suffix operate from 60 Hz input sources.

TABLE 1 SPECIFICATIONS, PRR GROUP

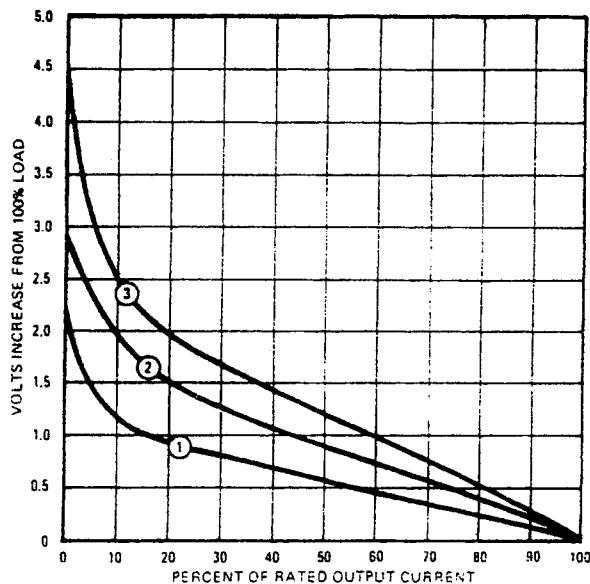

FIG. 2 TYPICAL LOAD EFFECT CURVES FOR PRR MODELS

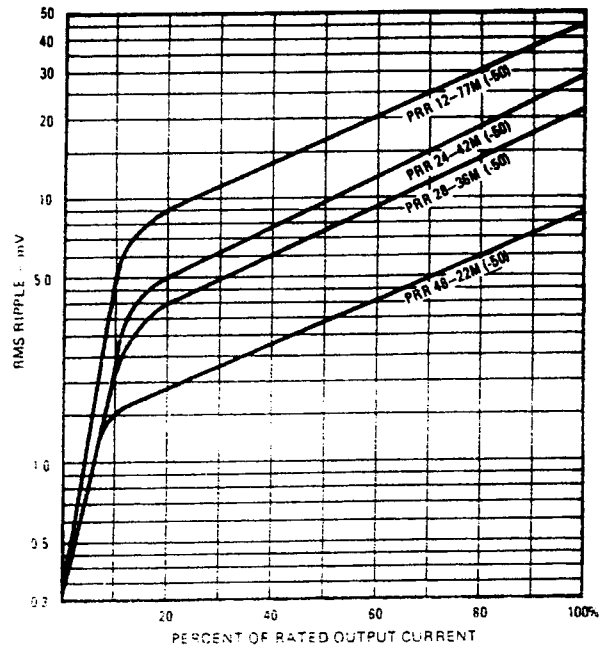

FIG. 3 TYPICAL OUTPUT RIPPLE CURVES FOR PRR MODELS

SPECIFICATIONS, ELECTRICAL (cont'd.)

DYNAMICS

- A) VOLTAGE RECOVERY TIME: The time required for the stabilized voltage to recover from a 50% step in load current to within the specified load effect band is less than 200 milliseconds.
- B) OUTPUT IMPEDANCE: The impedance at d-c and at frequencies below 10 KHz is a function of the load effect curves shown in FIG. 2. It may be determined from the slope of the plotted curves ($Z_o = \Delta E_o / \Delta I_o$). The output impedance at frequencies above 10 KHz can be computed by adding the effect of a 2 μ H series inductance to the low frequency value found in FIG. 2.

COOLING: Built-in forced air (fan) keeps the components in the PRR at safe operating temperatures. Full output power is delivered at 55°C. **NOTE:** CABINET OPENINGS ON THE PRR MUST BE KEPT CLEAR OF OBSTRUCTIONS.

ISOLATION: The output of the PRR is isolated from the chassis and ground. It can be floated to a maximum of 600V (d-c or peak) off ground. The common mode current between either output and ground is less than 50 μ A rms (500 μ A peak to peak) at 60 Hertz.

CURRENT LIMITING: The Kepco FLUX-O-TRAN[®] power transformer provides automatic current limiting at 125 to 150% of the rated load current, depending on the source voltage level.

BROWN-OUT PROTECTION: The PRR power supply functions (with reduced loading capacity) with reduced a-c input source levels to 75% of nominal.

SERIES/PARALLEL CONNECTION OF PRR SUPPLIES: For increased output voltage, PRR power supplies can be connected in series up to their isolation specification (600V max.). **Identical** PRR supplies may be paralleled for increased output current. To allow for imbalance, the total current must be derated by 10%, when connected in parallel.

STANDARDS: PRR power supplies are designed and tested in accord with the NEMA Standard for stabilized power supplies, d-c output, Publication No. PY-1-1972.

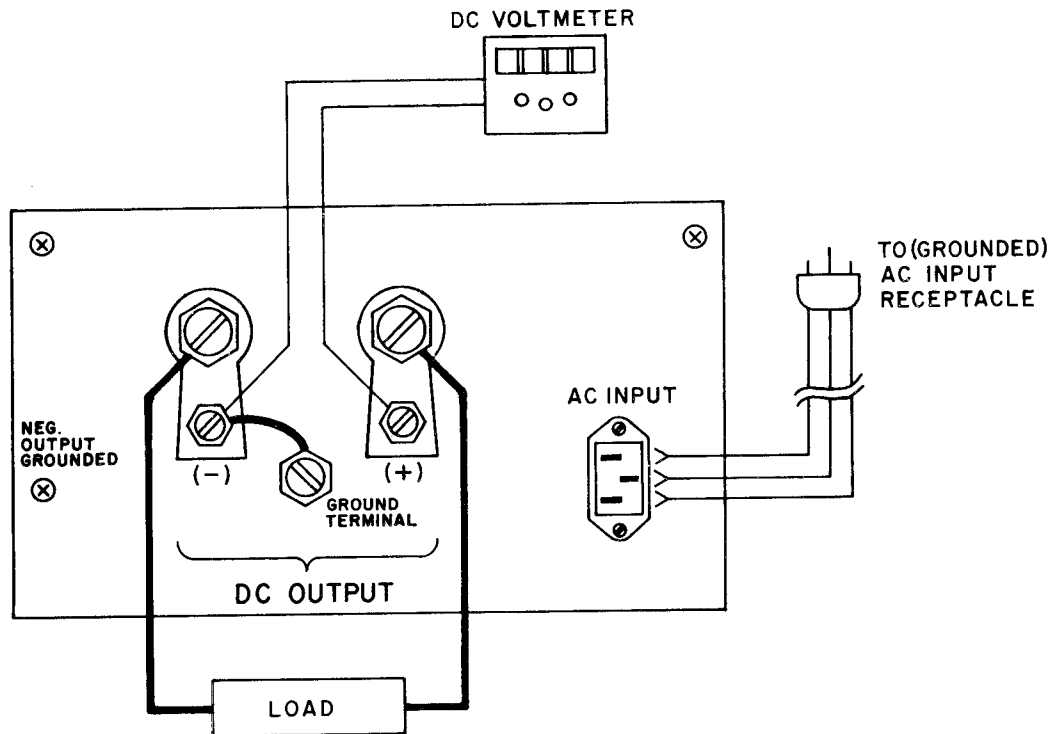

FIG 4 REAR TERMINATIONS, LOAD CONNECTIONS AND TECHNIQUE FOR MEASURING OUTPUT EFFECTS, PRR GROUP.

REAR TERMINATIONS AND LOAD CONNECTIONS: Figure 4 shows the rear terminations, the load connections and the techniques for measuring output effects. The load wires should be short, and as heavy as practicable.

GROUNDING (Safety):

WARNING

FOR SAFETY REASONS, THE CASE OF THIS POWER SUPPLY MUST BE GROUNDED AT ALL TIMES. AUTOMATIC SAFETY GROUNDING IS ACHIEVED BY USE OF THE PROVIDED 3-WIRE LINE CORD AND A SECURELY GROUNDED A-C OUTLET. IF A GROUNDED A-C OUTLET IS NOT AVAILABLE, THE CASE OF THE PRR MUST BE GROUNDED WITH A SEPARATE WIRE FROM THE PROVIDED GROUND TERMINAL ON THE PRR (SEE FIG. 4) TO A RELIABLE GROUND.

GROUNDING (Signal): For minimum ripple and noise, the PRR output/load circuit should be signal grounded as shown in FIG. 4. **Either** side of the output may be grounded, directly at the output terminals of the PRR as shown in FIG. 4, or at the load. If the PRR output must be operated without a ground (floating), capacitive grounding may be employed if necessary.

OUTPUT EFFECT MEASUREMENTS: The output specifications of the PRR may be verified by connecting a suitable voltmeter to the output terminals in FIG. 4, and varying the a-c power line (Source Effect measurement) and the load (Load Effect measurement) over the specified ranges. The meter connection shown in FIG. 4 minimizes voltage drops due to current flow and thus provides correct test results. Ripple specifications may be verified by connecting a suitable rms reading voltmeter in place of the d-c voltmeter.

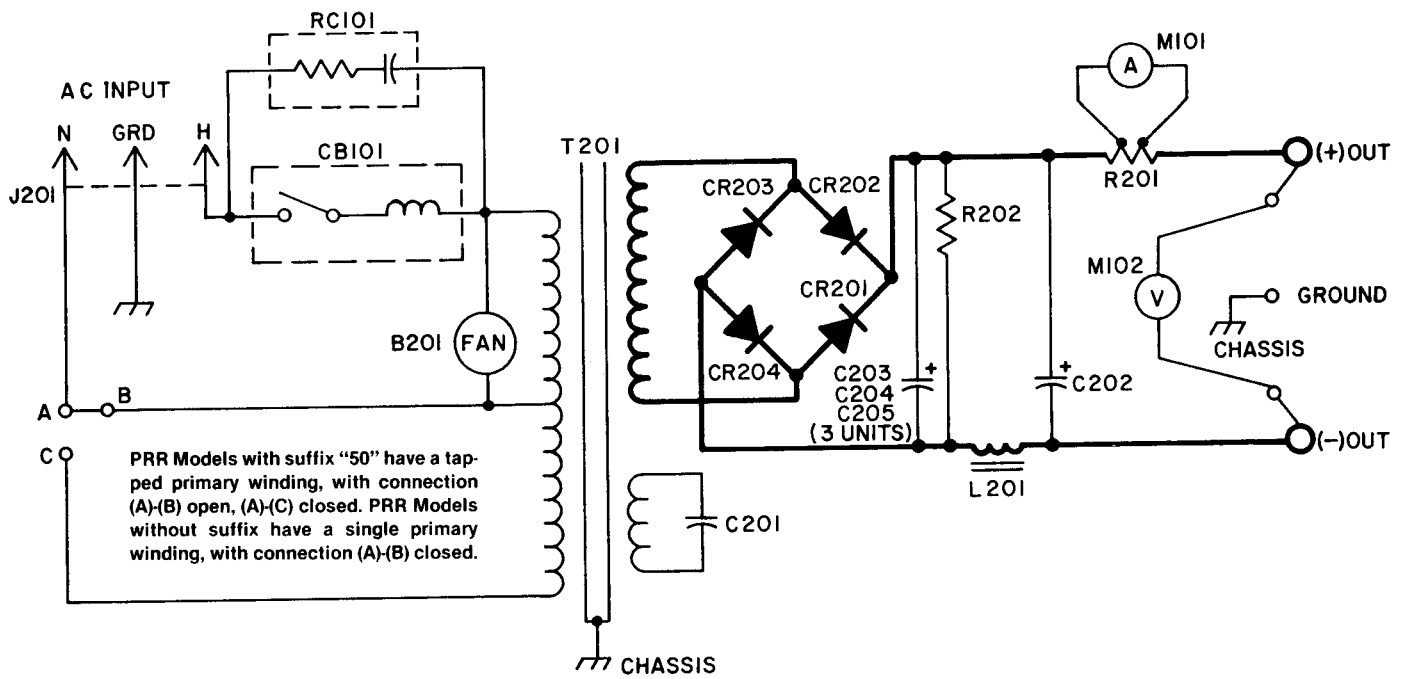

FIG. 6 SCHEMATIC DIAGRAM, PRR GROUP

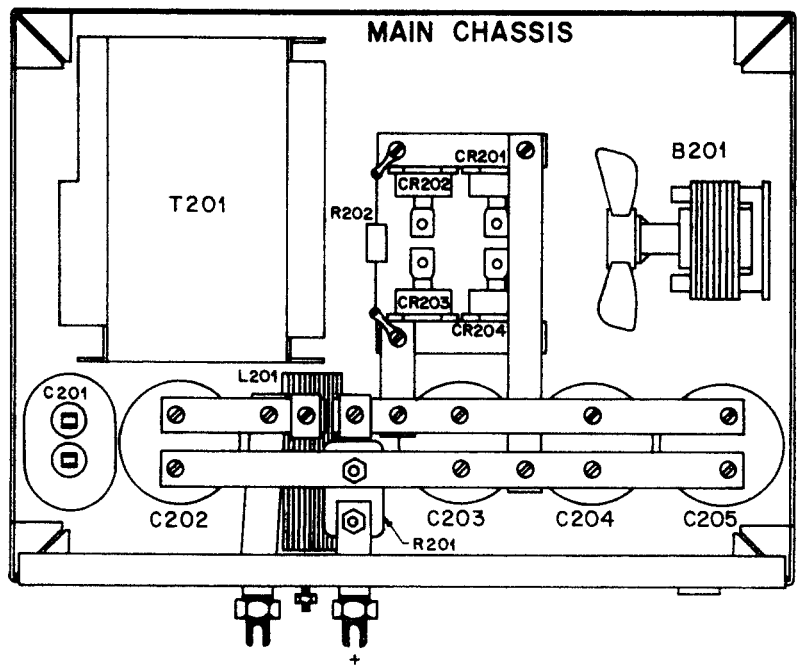
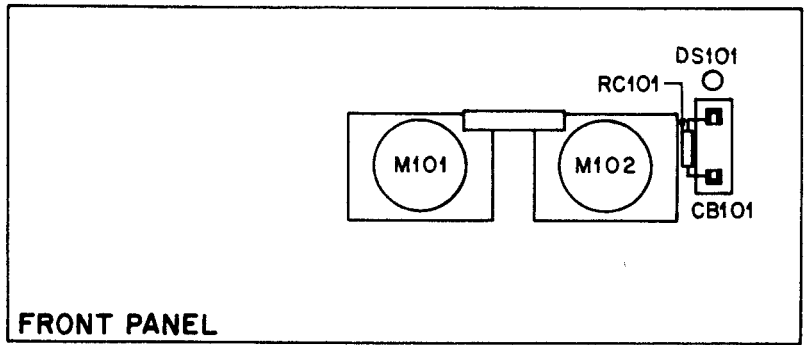

FIG. 7 COMPONENT LOCATION, PRR GROUP.



KEPCO REPLACEMENT PARTS LIST

PRR 48-22M (-50)

CHASSIS ASSEMBLY (A2) WITH FRONT PANEL

Code 04-2583

REFERENCE DESIGNATION	QTY.	DESCRIPTION	MFRS. NAME & PART NO. SEE BOTTOM NOTE	KEPCO PART NO.	REC. SPARE PART QTY.
-----------------------	------	-------------	--	----------------	----------------------

FRONT PANEL ASS'Y (PART OF A2) CONTAINS:

CB101 ⁽¹⁾	1	Circuit Breaker/Switch Series Trip, 15A, 240V	Heinemann JA1-A8-A-15-10	127-0330	1
CB101 ⁽²⁾	1	Circuit Breaker/Switch Series Trip, 7.5A, 240V	Heinemann JA1-A8-A-7.5-10	127-0360	1
DS101	1	Front Panel Pilot Light 115V a-c, Red	Industrial Devices 2100—GF-1-187	152-0087	1
M101	1	Ammeter (Ext. Shunt) 0 to 30A, (50 mV)	Kepeco Inc. 135-0511	135-0511	1
M102	1	Voltmeter (0-60V) 1k ohm/V	Kepeco Inc. 135-0514	135-0514	1
RC101	1	RC Network	Sprague Type 288P	245-0003	1

CHASSIS ASS'Y (A2) CONTAINS:

B201	1	Fan, Motor	Howard Industries Type 2312	148-0027	1
N.A.	1	Fan, Blade 4¼ inch dia., Nylon	Howard Industries 149-0023	149-0023	1
C201 ⁽¹⁾	1	Cap., Paper/Oil, Can, Oval 10µF, 6%, 660Va-c	General Electric Type 26F	117-0931	1
C201 ⁽²⁾	1	Cap., Paper, Can, Oval 8µF, ± 6%, 660V a-c	General Electric Type 26F	117-0873	1
C202,203 204,205	4	Cap., Elect., Can 40KµF, + 75, - 10%, 50V	Sprague Type 36DX	117-0884	1
CR201,202	2	Diode, Rect., Stud-Mtg. 200V, 15A	Motorola Type 1N3210	124-0555	1
CR203,204	2	Diode, Rect., Stud-Mtg. 200V, 15A	Motorola 1N3210R	124-0556	1
J201	1	a-c Input Jack 3 Term.	Switchcraft EAC-302	143-0290	1
L201	1	Filter Choke	Kepeco, Inc. 100-2086	100-2086	1
R201	1	Res., 4 Term. Type 50 mV, at 30A	Empco Mfg. Corp. MSA300	115-2638	1
R202	1	Res., Fixed, Power, W.W. 200 ohm, 20W	Memco Type FRL-20	115-2418	1
T201 ⁽¹⁾	1	Transformer, Power	Kepeco, Inc. 100-2085	100-2085	1
T201 ⁽²⁾	1	Transformer, Power	Kepeco Inc. 100-2103	100-2103	1

MISCELLANEOUS MECHANICAL PARTS

N.A.	2	Rear output terminals	151-0056
N.A.	2	Front panel handles	139-0197
N.A.	4	Bottom Feet, Aluminum	158-0004
N.A.	1	Unit Cover	129-0164
N.A.	1	Line Cord	118-0557

⁽¹⁾ Used in Model PRR 48-22M only. ⁽²⁾ Used in Model PRR 28-22M-50 only.

NOTE: REPLACEMENT PARTS MAY BE ORDERED FROM KEPCO, INC. ORDERS SHOULD INCLUDE KEPCO PART NUMBER AND DESCRIPTION.

PLEASE NOTE: THE MANUFACTURER'S NAME AND PART NUMBER LISTED FOR EACH ITEM ON REPLACEMENT PARTS LISTS REPRESENTS AT LEAST ONE SOURCE FOR THAT ITEM AND IS LISTED SOLELY FOR THE CONVENIENCE OF KEPCO EQUIPMENT OWNERS IN OBTAINING REPLACEMENT PARTS LOCALLY. WE RESERVE THE RIGHT TO USE EQUIVALENT ITEMS FROM ALTERNATE SOURCES. KEPCO, INC.



INSTRUCTION MANUAL CORRECTION

Please note the following corrections to the Manual Material as indicated:

Parts List and Schematic Diagram:

ERRATA:

1. TABLE 1 SPECIFICATIONS

Ripple (Max) RMS Volts:

Change from: 10mV
to: 15mV

2. Disregard Fig. 3

3. CHANGE:	CR203,204	Rectifier,Si.,Sutd	200V,(PIV),40A	Kepco #124-0556
To:	CR203,204	Rectifier,Si.,Sutd	200V,(PIV),40A	Kepco #124-0210
4. CHANGE:	B201	Motor,Fan	115Vac,50/60Hz	Kepco #148-0027
To:	B201	Motor,Fan	115Vac,50/60Hz	Kepco #148-0049
5. CHANGE:	Blade,Fan,CW Rotation		4.25" Dia.,5 Blade,Nylon	Kepco #149-0023
To:	Blade,Fan,CW Rotation		4.25" Dia.,5 Blade,7/32 HUB	Kepco #149-0031

PRR48-22M/12-2188/r3	ERRATA
PRR48-22M/02-0591/r4	C6298
PRR48-22M/01-2694/r5	C6750
PRR48-22M/06-1295/r6	C7319



INSTRUCTION MANUAL CORRECTION

Please note the following corrections to the Manual Material as indicated:

Parts List and Schematic Diagram:

ERRATA:

1. TABLE 1 SPECIFICATIONS

Ripple (Max) RMS Volts:

Change from: 10mV

to: 15mV

2. Disregard Fig. 3

3. CHANGE:	CR203,204	Rectifier,Si.,Sutd	200V,(PIV),40A	Kepeco #124-0556
To:	CR203,204	Rectifier,Si.,Sutd	200V,(PIV),40A	Kepeco #124-0210
4. CHANGE:	B201	Motor,Fan	115Vac,50/60Hz	Kepeco #148-0027
To:	B201	Motor,Fan	115Vac,50/60Hz	Kepeco #148-0049
5. CHANGE:	Blade,Fan,CW Rotation		4.25" Dia.,5 Blade,Nylon	Kepeco #149-0023
To:	Blade,Fan,CW Rotation		4.25" Dia.,5 Blade,7/32HUB	Kepeco #149-0031

PRR48-22M/50/12-2188/r3	ERRATA
PRR48-22M/50/02-0791/r4	C6296
PRR48-22M/50/01-2694/r5	C6751
PRR48-22M/50/06-1295/r6	C7230