

INSTRUCTION MANUAL

RA 19-4C RACK ADAPTER

HOT SWAP RACK ADAPTER FOR
HSF 300W, 600W, 1200W, 1500W SERIES POWER SUPPLIES

KEPCO INC.
An ISO 9001 Company.

 MODEL RA 19-4C RACK ADAPTER	
ORDER NO.	REV. NO.

IMPORTANT NOTES:

- 1) This manual is valid for the following Model and associated serial numbers:

MODEL	SERIAL NO.	REV. NO.
-------	------------	----------
- 2) A Change Page may be included at the end of the manual. All applicable changes and revision number changes are documented with reference to the equipment serial numbers. Before using this Instruction Manual, check your equipment serial number to identify your model. If in doubt, contact your nearest Kepco Representative, or the Kepco Documentation Office in New York, (718) 461-7000, requesting the correct revision for your particular model and serial number.
- 3) The contents of this manual are protected by copyright. Reproduction of any part can be made only with the specific written permission of Kepco, Inc.

Data subject to change without notice.

©2013, KEPCO, INC
P/N 243-1134-R2m



KEPCO, INC. ● 131-38 SANFORD AVENUE ● FLUSHING, NY. 11355 U.S.A. ● TEL (718) 461-7000 ● FAX (718) 767-1102
email: hq@kepcopower.com ● World Wide Web: <http://www.kepcopower.com>

TABLE OF CONTENTS

SECTION	PAGE
SECTION 1 - INTRODUCTION	
1.1	Scope of Manual 1-1
1.2	General Description..... 1-1
1.3	Electrical..... 1-1
1.4	Mechanical 1-3
1.5	Accessories 1-3
1.6	Options 1-3
SECTION 2 - INSTALLATION	
2.1	Unpacking and Inspection 2-1
2.2	Configuring the Rack Adapter 2-1
2.3	Rack Adapter Keying Instructions 2-1
2.3.1	Establishing Key Positions..... 2-2
2.4	Slot Configuration 2-2
2.4.1	Independent Operation 2-3
2.4.1.1	Using one power supply to control Multiple Power Supplies 2-3
2.4.1.2	Sense Connections for Independent Operation (HSF 300W and 600W Modules Only) 2-4
2.4.1.2.1	Independent Operation - Local Sensing Using Internal DIP switches 2-5
2.4.1.2.2	Independent Operation - Local Sensing Using External Wiring 2-6
2.4.1.2.3	Independent Operation - Remote Sensing 2-7
2.4.2	Parallel Operation 2-8
2.4.2.1	Individual Control 2-9
2.4.2.2	Group Control 2-11
2.4.2.3	Parallel, Master Selected by User, supplying balanced current to a single load 2-11
2.4.2.4	Current Balancing 2-14
2.4.2.5	Sense Connections for Parallel Configurations (HSF 300W and 600W Modules Only) 2-14
2.4.2.5.1	Parallel Configuration Using DIP Switches to Connect Sense Lines in Parallel 2-15
2.4.2.5.2	Parallel Configurations using External Wires to Connect Sense Lines in Parallel (HSF 300W and 600W Only) 2-17
2.4.3	Series Connection 2-19
2.5	Alarm Configurations 2-21
2.5.1	N.O. Alarm Line (Close on Failure)..... 2-21
2.5.1.1	Close on Failure Using Rear Panel Dip Switches..... 2-21
2.5.1.2	Close on Failure Using External Wiring at I/O Mating Connector 2-24
2.5.1.3	Close on Failure Using External Wiring at Alarm I/O Terminal Block 2-25
2.5.2	N.C. Alarm Line (Open on Failure) 2-25
2.5.2.1	Open on Failure Using Rear Panel Dip Switches 2-26
2.5.2.2	Open on Failure Using External Wiring of I/O Mating Connector 2-28
2.5.2.3	Open on Failure Using External Wiring of I/O Alarm Terminal Blocks 2-29
2.6	Terminations..... 2-29
2.7	Cooling 2-29
2.8	Installation 2-30
2.8.1	Installing Optional Protective Cover..... 2-30
2.8.2	Installing Optional Bus Bar 2-30
2.8.3	Installing Optional Locking Bracket..... 2-32
2.9	Installing HSF Power Supplies 2-33
2.10	Removing HSF Power Supplies 2-33
2.11	Wiring Instructions 2-33
2.11.1	Safety Grounding..... 2-34
2.11.2	Source Power Connections 2-34
2.11.2.1	EMI Compliance..... 2-35
2.11.3	Control Signal Connections 2-35
2.11.4	Output Load Connections 2-35
2.11.4.1	Reducing Ripple and Noise 2-35
2.11.4.2	Parallel/Redundant Operation..... 2-36

TABLE OF CONTENTS

SECTION		PAGE
2.11.4.3	Series/Independent Operation	2-36
2.11.4.4	Mixed Operation	2-36
2.12	Removing/Replacing HSF Power Supplies	2-36
2.13	Shipping.....	2-36

LIST OF FIGURES

FIGURE	TITLE	PAGE
1-1	RA 19-4C Rack Adapter	vi
1-2	RA 19-4C Rack Adapter with 300W, 600W, 1200W or 1500W HSF Power Supplies Installed.....	1-1
1-3	RA 19-4C Rear Panel Interconnections.....	1-2
1-4	RA 19-4C Rack Adapter Rear Panel	1-3
1-5	RA 19-4C Schematic Diagram.....	1-7
1-6	RA 19-4C Mechanical Outline Dimensions.....	1-9
2-1	RA 19-4C Rack Adapter Keying	2-2
2-2	Controlling Multiple Power Supplies, Multiple Loads	2-4
2-3	Independent Operation, Local Sensing for PS1 and PS2 using Internal DIP switches, Simplified Diagram	2-5
2-4	Independent Operation, Local Sensing for PS1 and PS2 using External Wiring, Simplified Diagram.....	2-6
2-5	Independent Operation, Remote Sensing for PS1 and PS2 using External Wiring at I/O Mating Connector or Euroblock, Simplified Diagram	2-7
2-6	Parallel Connection, Individual Control, Master-Slave, Single Load, Master Determined by Highest Output Voltage.....	2-10
2-7	Parallel, Master-Slave, Single Load, HSF DIP Switches Define Master and Voltage Control, RV, COM and CB lines Paralleled by Rack Adapter DIP Switches.....	2-12
2-8	Master-Slave, Single Load, HSF DIP Switches Define Master and Voltage Control, RV, COM and CB lines Paralleled by External Wiring at I/O Connector	2-13
2-9	Typical Parallel Connections Using External Wires for Local/Remote Sensing and DIP switches to parallel sense wires (HSF 300W and 600W only).....	2-16
2-10	Typical Parallel Connections using External Wires for Local/Remote Sensing and I/O Mating Connector Jumpers to Parallel sense wires (HSF 300W and 600W Only).....	2-18
2-11	Series Connection.....	2-20
2-12	Typical Close on Failure Alarm Configuration Using Rear Panel Dip Switches with Output from I/O Mating Connector, Simplified Diagram.....	2-22
2-13	Typical Close on Failure Alarm Configuration Using Rear Panel Dip Switches, with Output from Alarm I/O Terminal Blocks, Simplified Diagram.....	2-23
2-14	Close on Failure Alarm Configuration Using External Wiring at I/O Mating Connector, Simplified Diagram	2-24
2-15	Close on Failure Alarm Configuration Using External Wiring at Alarm I/O Terminal Block, Simplified Diagram	2-25
2-16	Typical Open on Failure Alarm Configuration Using Rear Panel Dip Switches with Output from I/O Mating Connector, Simplified Diagram.....	2-26
2-17	Typical Open on Failure Alarm Configuration Using Rear Panel Dip Switches with Output from Alarm I/O Terminal Blocks, Simplified Diagram	2-27
2-18	Open on Failure Alarm Configuration Using External Wiring at I/O Mating Connector, Simplified Diagram	2-28
2-19	Open on Failure Alarm Configuration Using External Wiring at I/O Alarm Terminal Blocks, Simplified Diagram	2-29
2-20	Optional Protective Cover or pARALLEL Bus Bar Installation	2-31
2-21	Series Bus Bar Installation	2-31
2-22	Optional Locking Bracket Installation.....	2-32
2-23	Ripple and Noise Measurement Setup Diagram.....	2-37

LIST OF TABLES

TABLE	TITLE	PAGE
1-1	Compatible HSF Power Supplies	1-4
1-2	RA 19-4C Accessories	1-4
2-1	Equipment Supplied	2-1
2-2	Rear Panel DIP Switch Functions	2-2
2-3	HSF DIP Switch Configuration for Group Control (allows Master to control Output WHILE Slaves Track Master) 2-11	
2-4	HSF DIP Switch Configuration for Voltage Control of Multiple Units in Series	2-19

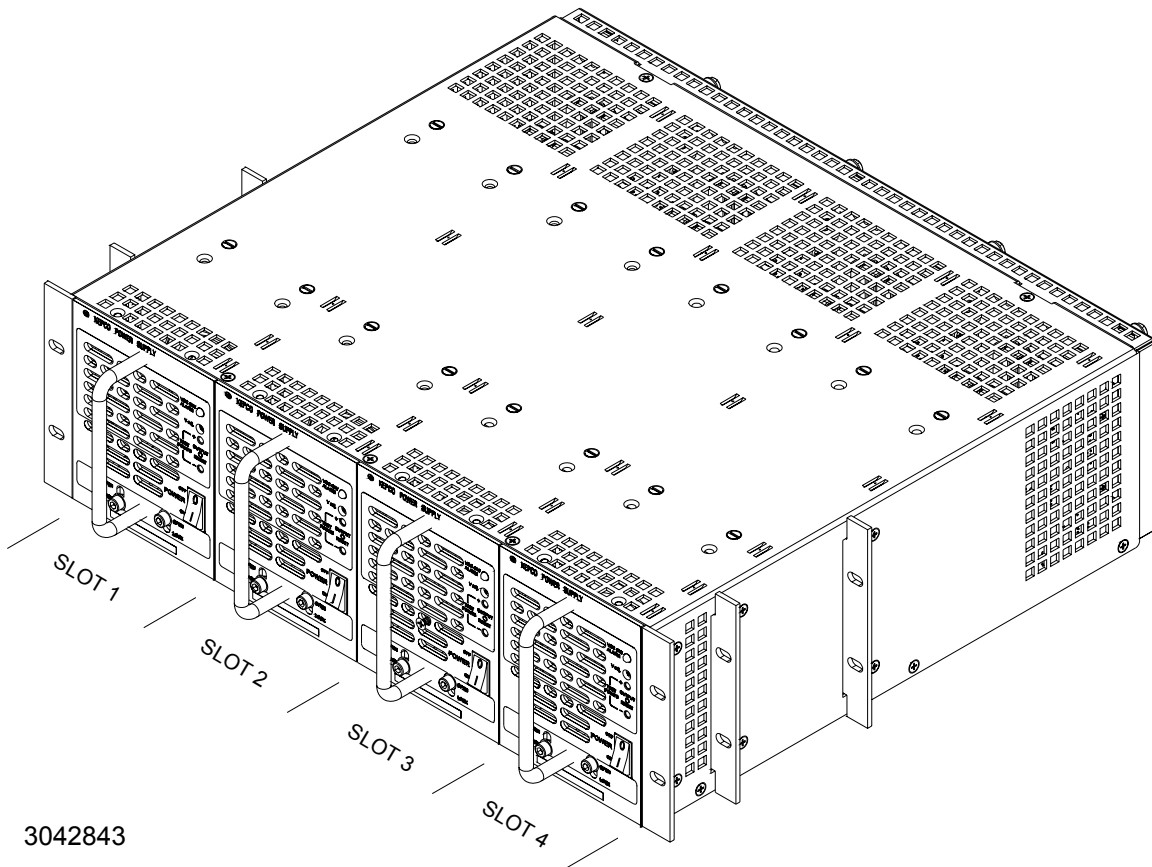

FIGURE 1-1. RA 19-4C RACK ADAPTER

SECTION 1 - INTRODUCTION

1.1 SCOPE OF MANUAL

This manual contains instructions for the installation and operation of the RA 19-4C plug-in rack adapter (Figure 1-1) used with 300W, 600W, 1200W and 1500W HSF power supplies, manufactured by Kepco, Inc., Flushing, New York, U.S.A.

1.2 GENERAL DESCRIPTION

Kepco RA 19-4C rack adapters are specifically designed for the installation of Kepco 300W, 600W, 1200W and 1500W HSF Power Supplies into 19-inch EIA-RS-310D standard equipment racks. The RA 19-4C Model accommodates up to four 300W, 600W, 1200W or 1500W HSF power supplies (Figure 1-2).

The rack adapter is user-configurable for parallel, series, or independent power supply operation. Up to four identical units may be connected in parallel. Multiple rack adapters may be paralleled for additional current capacity. Forced current sharing and OR'ing diodes for N+1 redundancy are built into the HSF power supplies. Redundant a-c inputs are provided to deliver independent source power to each power supply in a redundant pair. User-configurable keying ensures that only the correct power supply can be installed in a keyed slot.

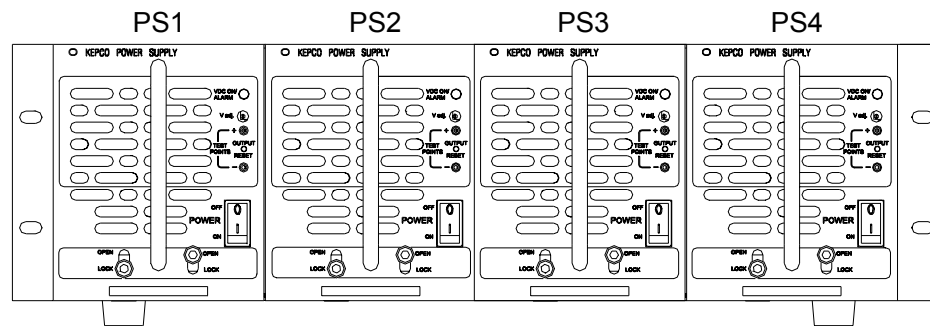

3042844

FIGURE 1-2. RA 19-4C RACK ADAPTER WITH 300W, 600W, 1200W OR 1500W HSF POWER SUPPLIES INSTALLED

1.3 ELECTRICAL

An internal PCB back plate mounts connectors which interface directly with the power and signal connectors of 300W, 600W, 1200W and 1500W HSF power supplies, permitting hot swappable insertion and extraction. The other side of the back plate assembly, available from the rear, contains the fixed power and signal connections. Figure 1-3 shows RA 19-4C Rack Adapter interconnections as well as details of the connectors and DIP switches located on the rear panel (see Figure 1-4). Dual input terminal blocks on the rear panel (Figure 1-4) distribute input power to each of the four power supplies. Figure 1-5 is a schematic diagram of the RA 19-4C Rack Adapter.

All mechanical specifications are contained in the mechanical outline drawing, Figure 1-6.

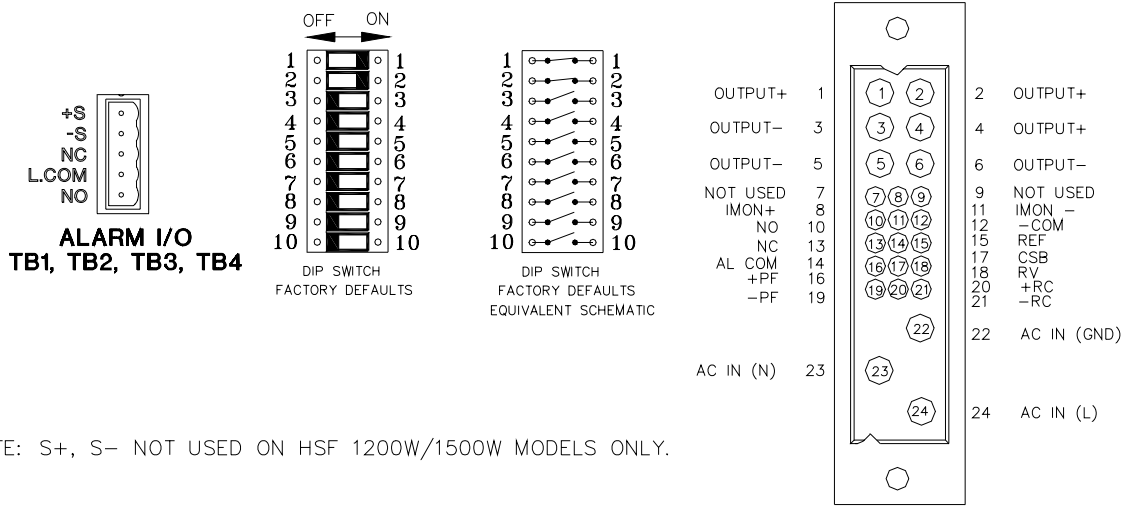
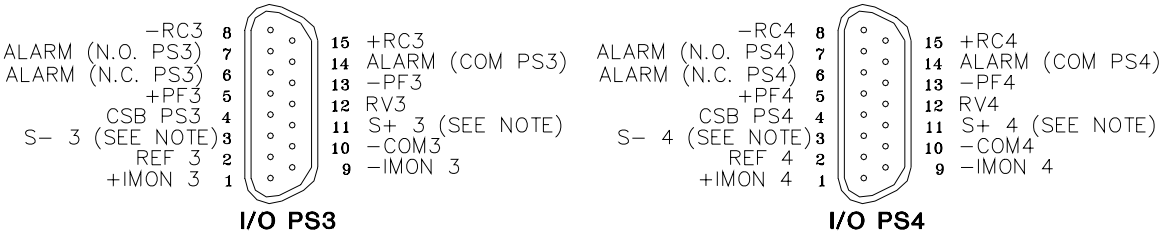
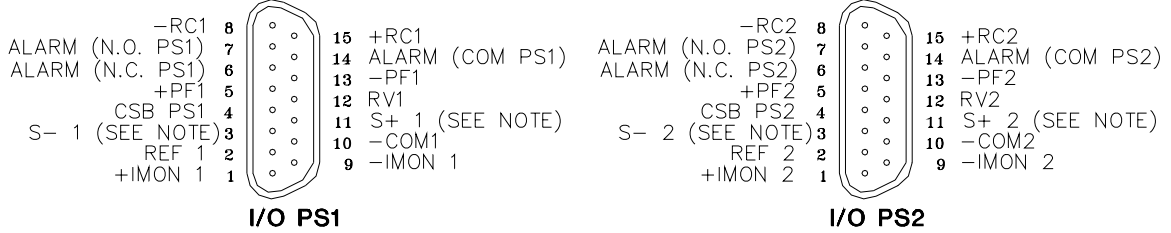
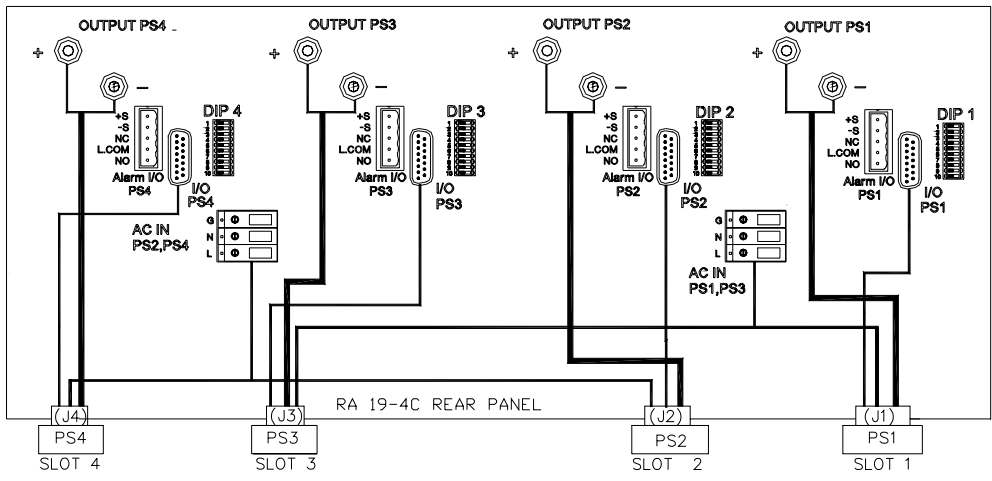

NOTE: S+, S- NOT USED ON HSF 1200W/1500W MODELS ONLY.

3042847

FIGURE 1-3. RA 19-4C REAR PANEL INTERCONNECTIONS

1.4 MECHANICAL

The rack adapter is equipped with mounting ears for mounting in EIA-RS-310D standard 19-inch racks. For mounting in non-standard racks, consult Kepco Applications Engineering. The rack adapter is not configured for slides. Optional blank filler panels (see Table 1-2) are available if the full complement of power supplies is not utilized.

Mechanical dimensions, material, and finish of the RA 19-4C Rack Adapter are provided in Figure 1-6.

1.5 ACCESSORIES

Accessories for RA 19-4C Rack Adapters are listed in Table 1-2; see also Table 2-1 for additional accessories supplied with the unit.

1.6 OPTIONS

Table 1-1 describes the standard model options available with the RA 19-4C rack adapter. For non-standard options, contact Kepco Applications Engineering for assistance.

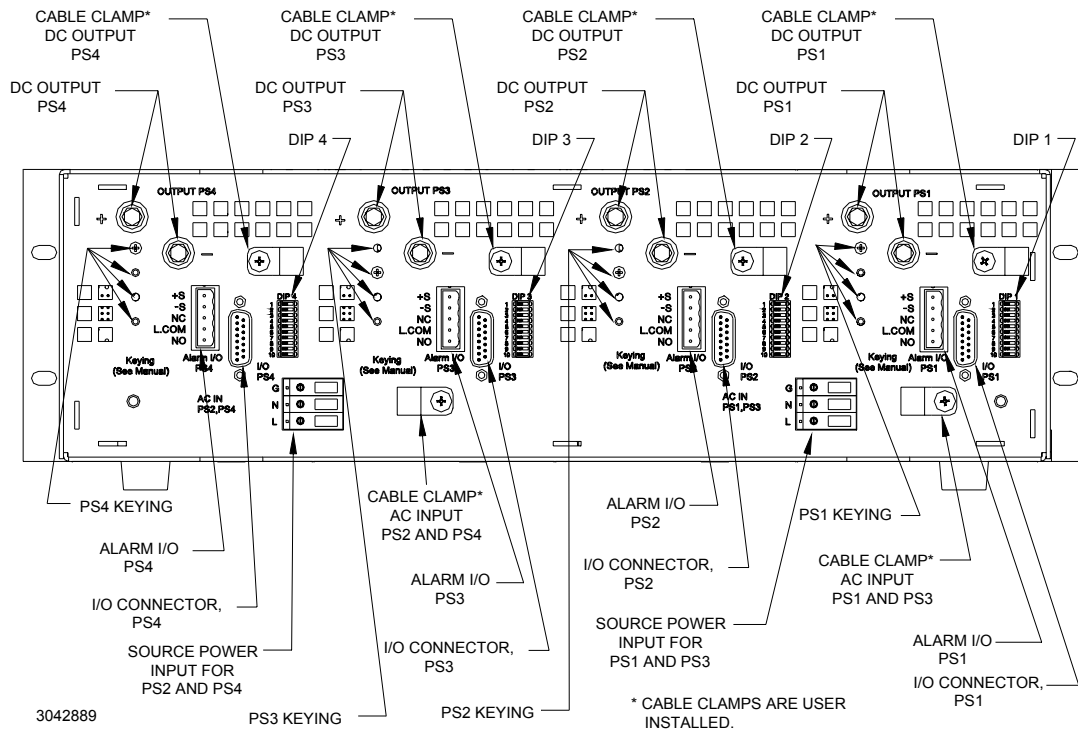

FIGURE 1-4. RA 19-4C RACK ADAPTER REAR PANEL

TABLE 1-1. COMPATIBLE HSF POWER SUPPLIES

MODEL	Total	Compatible HSF Models *			
		1200 Watts	1500 Watts	600 Watts	300 Watts
RA 19-4C	4 (max)	HSF 24-50	HSF 48-32 HSF 36-42	HSF 12-53 HSF 15-43 HSF 24-27 HSF 28-23 HSF 48-13	HSF 5-60 HSF 12-27 HSF 15-22 HSF 24-14 HSF 28-12 HSF 48-7

* Unless otherwise noted, Models that include a suffix specifying an option, e.g., M for Meter, C for Current Monitoring, etc., are compatible. Contact Kepco Applications Engineering for assistance with non-standard configurations.

TABLE 1-2. RA 19-4C ACCESSORIES

ACCESSORY	PART NUMBER	USE
Screw, Thread forming (4-40, 0.75 in. long, PHPH)	101-0480	Module Keying. eight (8) supplied with unit. Installed by user (see PAR. 2.3).
Line cord	118-1145	Connect to 30A, 125-250V a-c source power via NEMA 10-30P connection.
Line cord	118-1146	Connect to 32A, 250V a-c source power via IEC 309 connection.
Connector	142-0449	Mating Connector for I/O connector. Four (4) supplied with unit.
Filler Panel (1/4 Rack)	RFP 19-14C	Cover one unused 1/4 rack slot.
Filler Panel (1/2 Rack)	RFP 19-12C	Cover two unused 1/4 rack slots.
Bus bar, Series	172-0593	Connect Output Terminals, (-) to (+) for series operation.
Bus bar, Parallel, 2 Slots (Clearance: 2.6mm)	172-0590	Connect slots 1 and 2, 2 and 3, or 3 and 4 in parallel; two bus bars required for each paralleled slot: one for (+), one for (-). Bus bar is 3/32 in. thick, clearance between (+) and (-) is 2.6mm with two output studs. Each stud is 5/16-18, 1.2-inch long minimum.
Bus bar, Parallel, 2 Slots, 1 Output Stud (Clearance: 6.4mm)	172-0607	Same as P/N 172-0590 except bus bar is 1/8 in. thick and clearance between (+) and (-) is 6.4mm; only one (1) output stud (5/16-18) per busbar. Each stud is 5/16-18, 1.2-inch long minimum.
Bus bar, Parallel, 2 Slots 2 Output Studs (Clearance: 6.4mm)	172-0615	Same as P/N 172-0590 except bus bar is 1/8 in. thick and clearance between (+) and (-) is 6.4mm with two (2) output studs per busbar. Each stud is 5/16-18, 1.2-inch long minimum.
Bus Bar, Parallel, 3 Slots (Clearance: 4.5mm)	172-0591	Connect slots 1, 2 and 3, or 2, 3 and 4 in parallel; two bus bars required for each paralleled set of slots: one for (+), one for (-). Bus bar is 1/8 in. thick, clearance between (+) and (-) is 4.5mm with two (2) output studs per busbar. Each stud is 5/16-18, 1.2-inch long minimum.
Bus Bar, Parallel, 3 Slots (Clearance: 6.4mm)	172-0608	Same as P/N 172-0591 except clearance between (+) and (-) is 6.4mm.
Bus Bar, Parallel, 4 Slots (Clearance: 4.5mm)	172-0592	Connect slots 1 through 4 in parallel; two bus bars required for each rack adapter: one for (+), one for (-). Bus bar is 1/8 in. thick, clearance between (+) and (-) is 4.5mm with three (3) output studs per busbar. Each stud is 5/16-18, 1.2-inch long minimum.
Bus Bar, Parallel, 4 Slots (Clearance: 6.4mm)	172-0609	Same as P/N 172-0592 except clearance between (+) and (-) is 6.4mm.
Bus Bar, Series	172-0593	Connects adjacent slots (+) to (-) to series configurations.
Hex Nut (5/16-18)	102-0105	Attach load cables to studs of optional bus bars.
Protective cover	137-0145	Clear plastic cover, protects against accidental contact with DC output terminals. Four standoffs (not supplied), Kepco P/N 104-0385, required for installation
Standoff (Protective cover)	104-0385	Four (4) required to install protective cover, Kepco P/N 137-0145. Male/female, 8-32 x 1.5 in. long

TABLE 1-2. RA 19-4C ACCESSORIES (CONTINUED)

ACCESSORY	PART NUMBER	USE
Setback Ear Brackets, 19 inch Rack (2 required)	128-2168	Used to mount rack adapter in 19-inch rack using "set back" position for applications that require reduced depth protrusion (see Figure 1-6).
Ear Brackets, 23 inch Rack (2 required)	128-1895	Used to mount rack adapter in 23-inch rack, front mount only. For "set back" position for applications that require reduced depth protrusion contact Kepco
Adapter Brackets, 24 inch Rack (2 required)	108-0386	Used to mount rack adapter in 24-inch rack (EMCOR P/N ABA05)
Screws ((8 required, 4 for each ear bracket)	101-0446	Used to attach ear brackets to rack adapter chassis.(6-32 x 1/4, Flat Head Phillips Tri-torq, Tubular Self Forming.
Connector, Euro-plug	142-0544	Mating connector for ALARM TB1-TB4 Euro-header.
Slide Kit (bottom mount)	219-0508	Allows rack adapter to slide out from the front. Requires additional 1U (1.75 in.) minimum height)
Locking Bracket	See PAR. 2.8.3; consult factory	Provides additional reinforcement for severe vibration or shock environments.
Support Bracket	128-1775	Pair required. Used to provide side support for rack adapter. Requires rear rail at 18-13/16 in. setback.

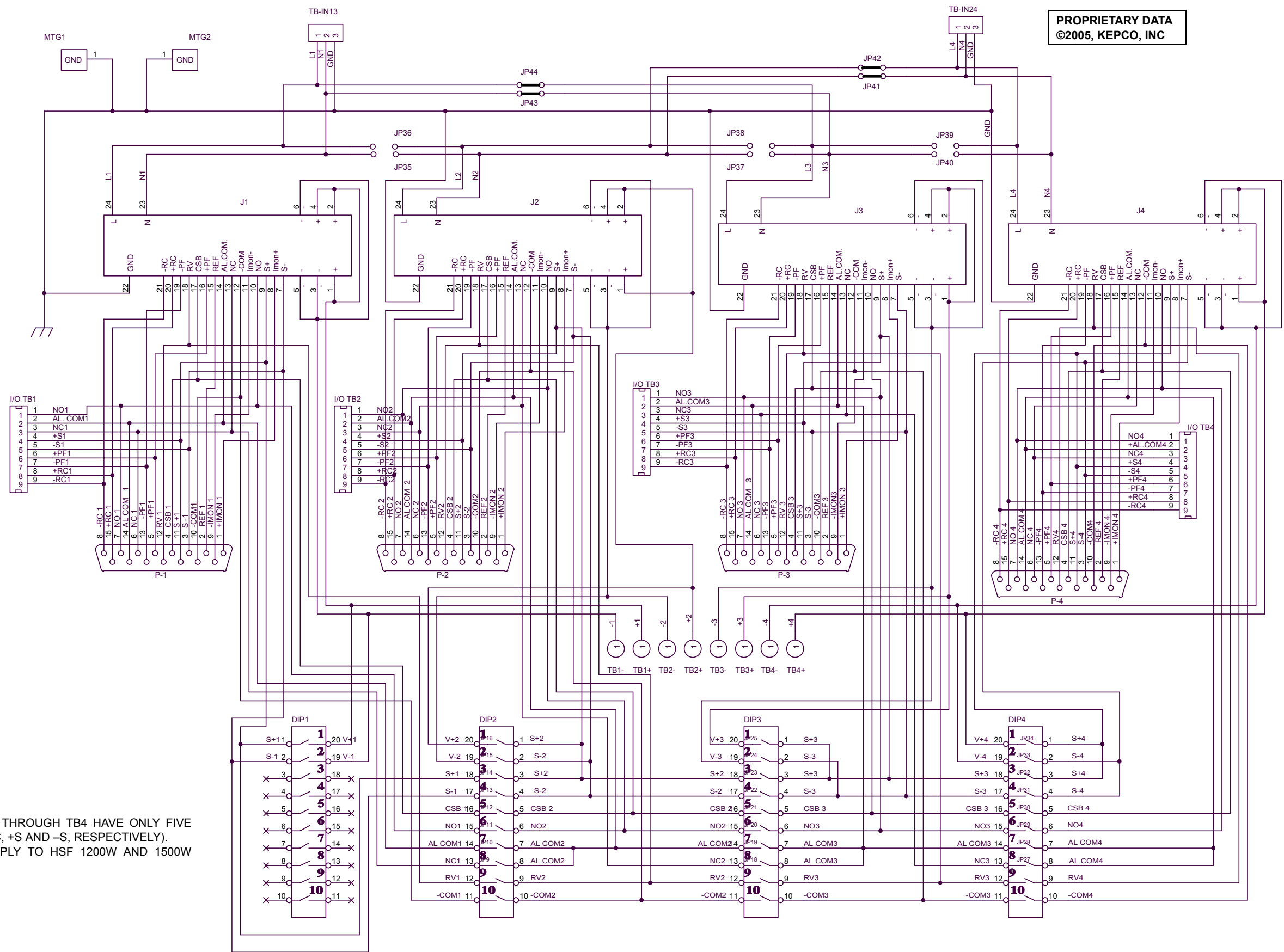

- NOTES:
1. ALARM I/O TERMINAL BLOCKS TB1 THROUGH TB4 HAVE ONLY FIVE PINS: 1 THROUGH 5 (NO, AL COM, NC, +S AND -S, RESPECTIVELY).
 2. SENSE CONNECTIONS DO NOT APPLY TO HSF 1200W AND 1500W UNITS.

3020736

FIGURE 1-5. RA 19-4C SCHEMATIC DIAGRAM

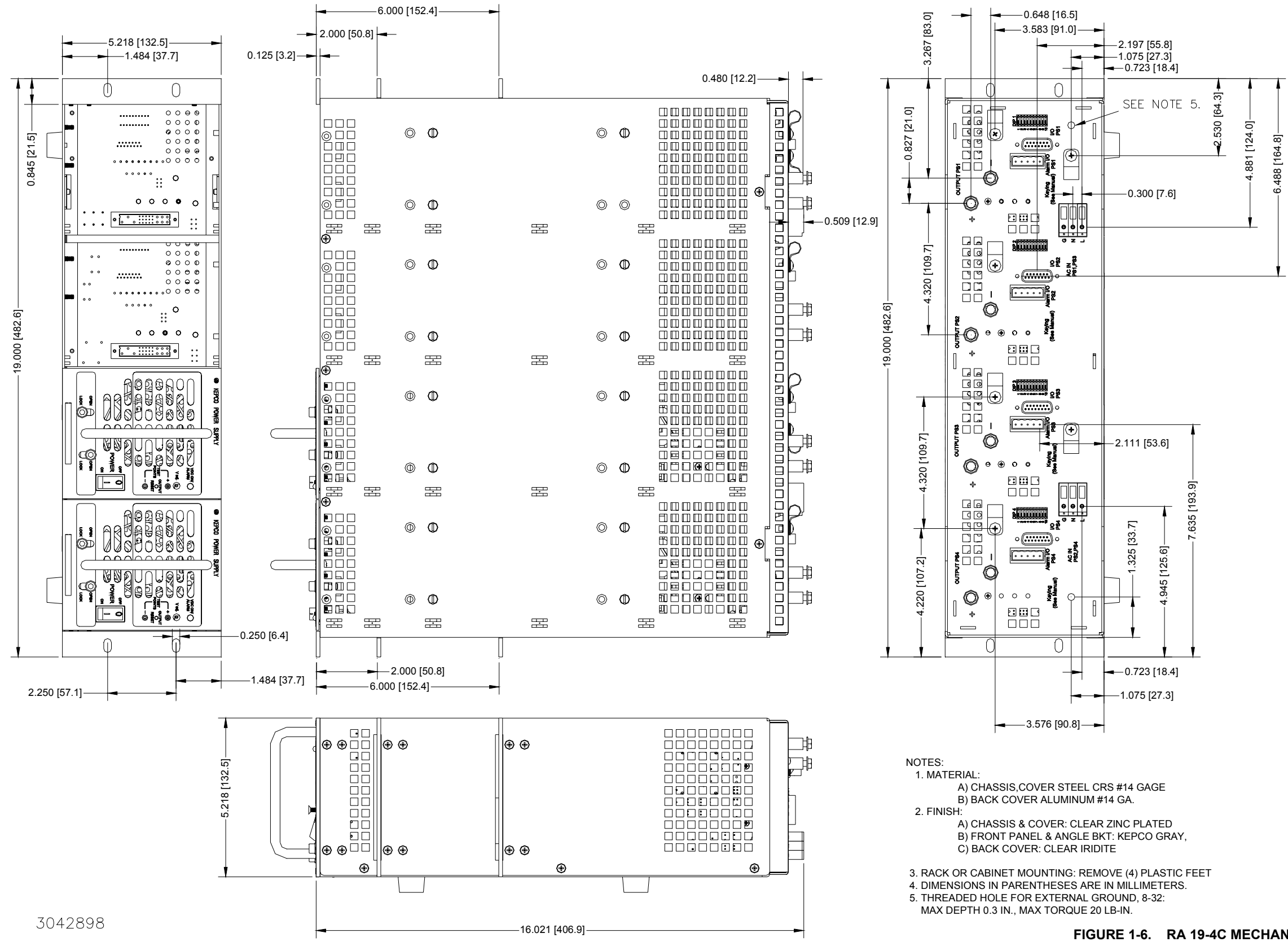

- NOTES:
- MATERIAL:
 - CHASSIS, COVER STEEL CRS #14 GAGE
 - BACK COVER ALUMINUM #14 GA.
 - FINISH:
 - CHASSIS & COVER: CLEAR ZINC PLATED
 - FRONT PANEL & ANGLE BKT: KEPCO GRAY,
 - BACK COVER: CLEAR IRIDITE
 - RACK OR CABINET MOUNTING: REMOVE (4) PLASTIC FEET
 - DIMENSIONS IN PARENTHESES ARE IN MILLIMETERS.
 - THREADED HOLE FOR EXTERNAL GROUND, 8-32:
MAX DEPTH 0.3 IN., MAX TORQUE 20 LB-IN.

FIGURE 1-6. RA 19-4C MECHANICAL OUTLINE DIMENSIONS

SECTION 2 - INSTALLATION

2.1 UNPACKING AND INSPECTION

This equipment has been thoroughly inspected and tested prior to packing and is ready for operation. After careful unpacking, inspect for shipping damage before attempting to operate. If any indication of damage is found, file an immediate claim with the responsible transport service. See Table 2-1 for a list of equipment supplied.

TABLE 2-1. EQUIPMENT SUPPLIED

ITEM	QUANTITY	PART NUMBER
Rack Adapter	1	RA 19-4C
I/O Connector (Mating)	4	142-0449
Instruction Manual	1	243-1130
Keying screws (4-40 x 0.75 in., thread forming)	8	101-0480
Hood for I/O Connector (Mating) P/N 142-0449	4	108-0204
Cable clamp	6	138-0063
Chassis Feet	4	158-0008
Output connection screw (10-32 x 1/2, Hex head)	8	101-0365
Output connection washer #10 (ID: 0.210, OD: 0.433 .039 thk, steel)	8	103-0136
Screw, BHPH 6-32X 0.500ST (attach feet)	4	101-0019
Washer, Flat, No. 6 (attach feet)	4	103-0100
Lockwasher, No. 6 (attach feet)	4	103-0015

2.2 CONFIGURING THE RACK ADAPTER

Prior to installation the rack adapter must be configured by the user. Configuration consists of the following:

- For configurations that use multiple output voltages it is possible to key the rack adapter to accept only a power supply with corresponding keying (see PAR 2.3).
- Configuring slots for independent, parallel, or series operation. This can be done by means of DIP switches mounted on the rear panel, or externally by wiring the associated I/O mating connector or mating Euro plug and (+) and (-) OUTPUT terminals (see PAR. 2.4).

2.3 RACK ADAPTER KEYING INSTRUCTIONS

RA 19-4C rack adapters incorporate a keying mechanism to prevent accidental insertion of the incorrect model HSF power supply into any position. The HSF power supplies are keyed by voltage at the factory. The keying mechanism will prevent engagement of any of the HSF power supply's connectors with those on the rack adapter's back plate unless the key and keyway align. The key pins are on the HSF power supply and are set at the factory. **DO NOT ALTER THE KEYING AT THE POWER SUPPLY.** The keyway is established by installing screws (provided) so that the only open holes match the power supply pins; maximum torque is 5 in.-lbs. The user can configure each power supply slot for the desired voltage in the desired position. Figure 1-4 shows the location of key positions for each slot and Figure 2-1 shows the configuration required for voltage selection.

2.3.1 ESTABLISHING KEY POSITIONS

To establish the keying of any position, simply install the 4-40 x 0.75 in. thread-forming screws (Kepco P/N 101-0480) into the corresponding holes as indicated in Figure 2-1. DO NOT OVERTIGHTEN these screws (max torque 5 in.-lbs. (0.6 N x m). DO NOT ALTER THE KEYING AT THE POWER SUPPLY.

DESIRED VOLTAGE →	5V	12V	15V	24V	28V	48V
⊕ = SCREW TO BE INSTALLED AT REAR PANEL.	⊕	⊕	○	⊕	○	○
○ = NO SCREW INSTALLED.	⊕	○	○	○	⊕	⊕
	○	○	⊕	⊕	○	⊕
	○	⊕	⊕	○	⊕	○

3042848

FIGURE 2-1. RA 19-4C RACK ADAPTER KEYING

2.4 SLOT CONFIGURATION

Configuring slots of the rack adapter for independent, parallel or series operation is accomplished either by means of DIP switches mounted on the rear panel associated with each slot (see Figure 1-3), or externally by connecting the appropriate pins of the associated I/O mating connector. DIP switch functions are explained in Table 2-2. The schematic diagram (Figure 1-5), which shows all internal connections, is provided as a reference.

Slot configuration requires the following selection:

1. Select independent (PAR. 2.4.1), parallel (PAR. 2.4.2), or series (PAR. 2.4.3) operation.
2. Optional: Select close-on-failure or open-on-failure alarm (PAR. 2.5).

TABLE 2-2. REAR PANEL DIP SWITCH FUNCTIONS

DIP SWITCH POSITION	FUNCTION	DIP SWITCH SET TO ON (CLOSED)	DIP SWITCH SET TO OFF (OPEN)
NOTE: BOLD TYPE INDICATES FACTORY SETTINGS.			
1, 2 (SEE NOTE)	Local / Remote Sensing Selection	Required ON (factory default) for independent operation with Local Sensing. Position 1 connects V+ to S+, Position 2 connects V- to S- (see PAR. 2.4.1.2).	Position 1 and 2 required OFF for: a) Independent configurations using Remote Sensing (see PAR. 2.4.1.2). b) Independent configurations using Local Sensing with user supplied connections from V+ to S+ and V- to S- (see PAR. 2.4.1.2). c) All parallel configurations (sensing must be established using external wires) (see PAR. 2.4.2.5). d) All series connections (see PAR. 2.4.3).
NOTE: Positions 1, 2, 3, 4 not used for HSF 1200W and 1500W modules; leave in default position.			

TABLE 2-2. REAR PANEL DIP SWITCH FUNCTIONS (CONTINUED)

DIP SWITCH POSITION	FUNCTION	DIP SWITCH SET TO ON (CLOSED)	DIP SWITCH SET TO OFF (OPEN)
3, 4 (SEE NOTE)	Connect Sense + and – in parallel	Required ON for parallel configurations using DIP switch settings to connect the sense leads in parallel. Position 3 connects +S to adjacent slot +S, Position 4 connects –S to adjacent slot –S (see PAR.2.4.2.5.1 (DIP switches) and 2.4.2.5.2 (external wiring)).	Position 3 and 4 required OFF (factory default) for all configurations except parallel configurations using DIP switch settings to connect the sense leads in parallel.
5	Current Balance	Required ON for parallel operation with forced current share (connects current share lines in parallel) unless connections are made via external wires (see PAR. 2.4.2.4).	Required OFF (factory default) for a) independent and series configurations. b) Parallel configurations using external wires at I/O connector to connect CSB (current share bus) lines in parallel. c. Parallel configurations without forced current sharing (current balancing),
6, 7	Close on Failure Alarm	When set to ON, allows a single alarm to provide failure indication (contact closure between N.O. pin and COM pin) if any one of many power supplies fails (see PAR. 2.5.1).	When set to OFF (factory default), individual power supplies produce closure between I/O connector N.O. and COM pins upon failure (see PAR. 2.5.1).
8	Open on Failure Alarm	When set to ON, allows a single alarm to provide failure indication (contact open between N.C. pin and COM pin) if any one of many power supplies fails (see PAR. 2.5.2).	When set to OFF (factory default), individual power supplies produce open between I/O connector N.C. and COM pins upon failure (see PAR. 2.5.2).
9	Remote Voltage	When both set to ON, enables control of multiple supplies from power supply designated as the Master.	When both set to OFF allows independent voltage control of each power supply
10	-Common		

NOTE: Positions 1, 2, 3, 4 not used for HSF 1200W and 1500W modules; leave in default position.

2.4.1 INDEPENDENT OPERATION

The rack adapter is preconfigured at the factory for independent operation of all slots. DIP switch positions 3 through 5 associated with each slot must be set to OFF (open) for each power supply to be operated independently. *HSF 300W and 600W modules must have sense connections configured to work properly (see PAR. 2.4.1.2).*

2.4.1.1 USING ONE POWER SUPPLY TO CONTROL MULTIPLE POWER SUPPLIES

Figure 2-2 shows the connection of three power supplies each having an independent load. In this configuration the output voltage of all three power supplies is controlled by one power supply (master) and the current drawn by each power supply is determined by the respective load. Refer to PAR. 2.4.2.1 to select local or remote voltage control.

The connections between RV and -COM may be made using the rack adapter DIP switches or by wiring the I/O mating connector as shown in Figure 2-2. Using external wiring at the I/O mating connector allows configuration of non-adjacent slots. Use shielded wire for connections to RV pins. *HSF 300W and 600W modules MUST have sense connections configured to work properly (see PAR. 2.4.1.2)*

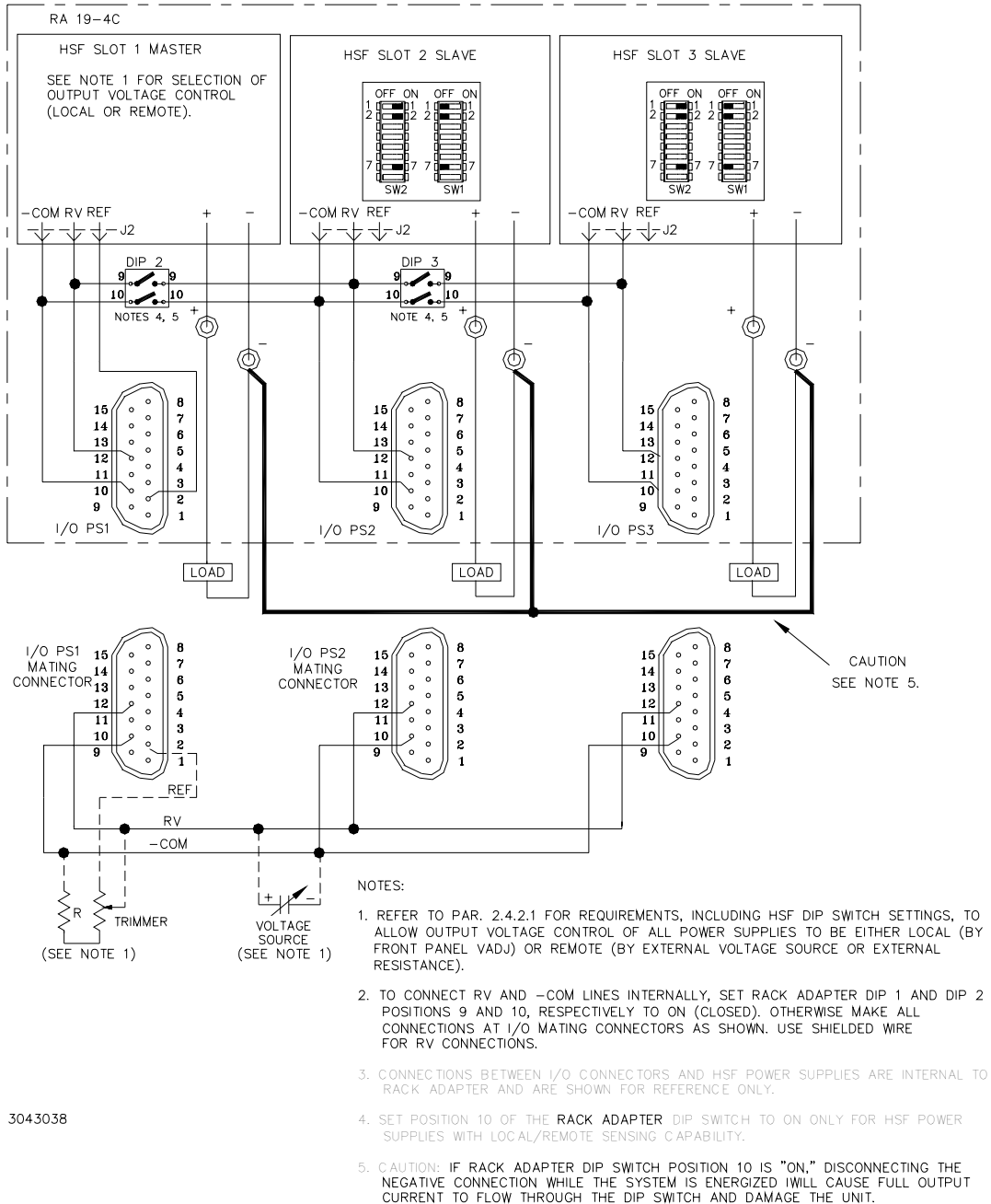

3043038

FIGURE 2-2. CONTROLLING MULTIPLE POWER SUPPLIES, MULTIPLE LOADS

2.4.1.2 SENSE CONNECTIONS FOR INDEPENDENT OPERATION (HSF 300W AND 600W MODULES ONLY)

The rack adapter is shipped from the factory with each power supply position configured for local sensing (see Figure 2-3). Sensing for each slot can be configured independently:

- Local sensing using internal DIP switches
- Local sensing using external jumpers connected to the I/O mating connector or the DC OUTPUT terminal block.
- Remote sensing

2.4.1.2.1 INDEPENDENT OPERATION - LOCAL SENSING USING INTERNAL DIP SWITCHES

The rack adapter slots are preconfigured at the factory for local sensing using internal DIP switches. If a slot has been configured for other than local sensing using DIP switches and it is necessary to reconfigure it for local sensing, simply set positions 1 and 2 of the DIP switch associated with that slot to ON (closed). External sensing connections must be removed. When set to ON (closed) DIP switch position 1 connects (V+) to (S+) and position 2 connects (V-) to (S-). See Figure 1-3 for DIP switch locations. Figure 2-3 illustrates local sensing of PS1 and PS2 by setting positions 1 and 2 of internal DIP switches B3 and C4 to ON (closed); positions 3 and 4 must be set to OFF (open). Position 5 (current share) must be set to OFF and positions 6, 7, and 8 (alarms) can be configured per PAR. 2.5.

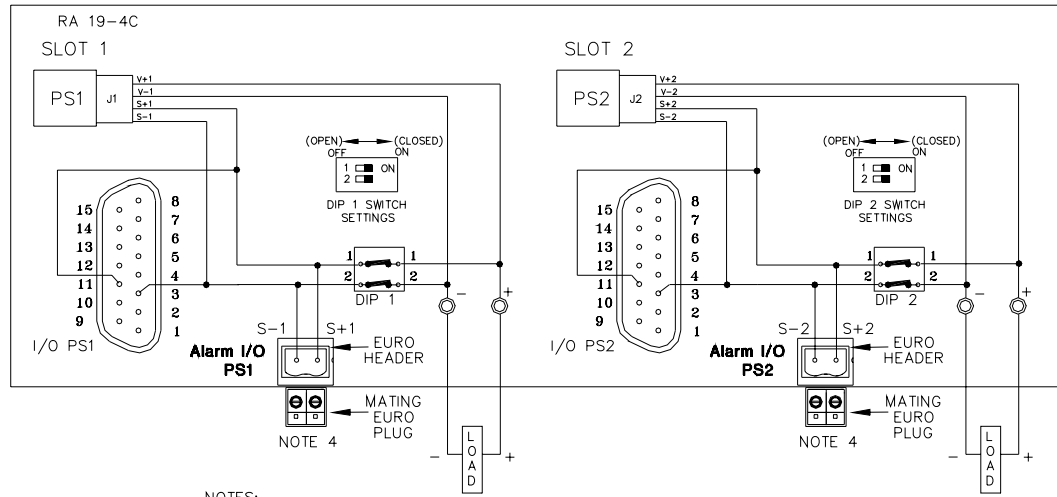

NOTES:

1. SET DIP SWITCH POSITIONS 1 AND 2 TO ON (CLOSED) FOR LOCAL SENSING. NO OTHER SENSE CONNECTIONS ARE REQUIRED.
2. CONNECTIONS TO I/O CONNECTORS, EURO HEADERS AND DIP SWITCHES ARE INTERNAL AND SHOWN FOR REFERENCE ONLY.
3. I/O MATING CONNECTOR VIEWED FROM FRONT (MATING FACE) FOR EASE OF LOCATING CORRESPONDING I/O CONNECTOR PINS.
4. ONLY TWO POSITIONS SHOWN.

3042908

FIGURE 2-3. INDEPENDENT OPERATION, LOCAL SENSING FOR PS1 AND PS2 USING INTERNAL DIP SWITCHES, SIMPLIFIED DIAGRAM

2.4.1.2.2 INDEPENDENT OPERATION - LOCAL SENSING USING EXTERNAL WIRING

To configure a slot for local sensing using external wiring, first set internal DIP switch positions 1 and 2 of the DIP switches associated with that slot to OFF (open).

External local sensing is accomplished by connecting (V+) to (S+) and (V-) to (S-). This can be done at either the mating I/O connector supplied (see Table 2-1) or the DC OUTPUT terminal block. See Figure 1-3 for DIP socket locations. Figure 1-3 illustrates I/O connector pin assignments. Figure 2-4 illustrates local sensing of PS1 and PS2 using external jumpers connected to the I/O mating connector.

NOTE: The internal DIP switch settings established at the factory for positions 1 and 2 of the associated DIP switch **MUST** be changed to OFF (open) if this option is chosen.

Positions 3 and 4 (connecting sense lines in parallel) and Position 5 (current share) must be set to OFF. Configure Positions 6, 7, and 8 (alarms) per PAR. 2.5.

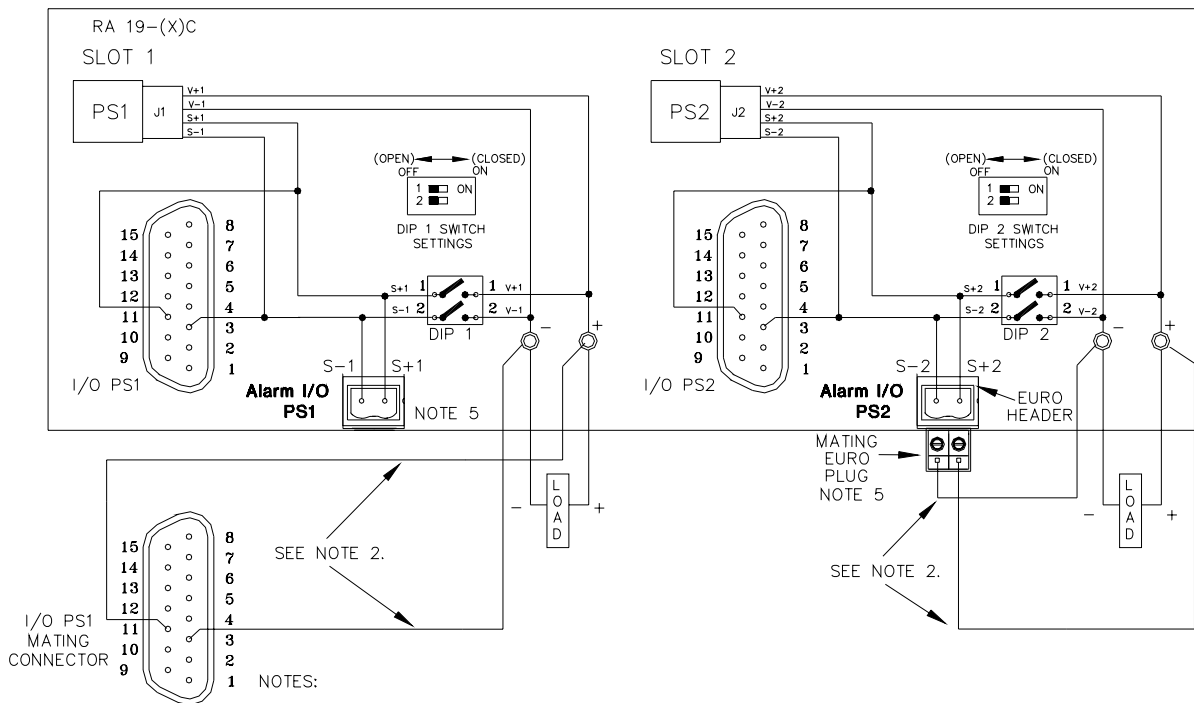

3042914

FIGURE 2-4. INDEPENDENT OPERATION, LOCAL SENSING FOR PS1 AND PS2 USING EXTERNAL WIRING, SIMPLIFIED DIAGRAM

2.4.1.2.3 INDEPENDENT OPERATION - REMOTE SENSING

Remote sensing is accomplished by connecting +Load to (S+) and –Load to (S–). Figure 2-5 illustrates remote sensing for PS1 and PS2 using wires connected to the I/O mating connector for PS1 and wires connected to the mating Euro plug for PS2.

NOTE: The internal DIP switch settings established at the factory for positions 1 and 2 of the associated DIP switch MUST be changed to OFF (open) if this option is chosen.

Positions 3 and 4 (connecting sense lines in parallel) and Position 5 (current share) must be set to OFF. Configure Positions 6, 7, and 8 (alarms) per PAR. 2.5.

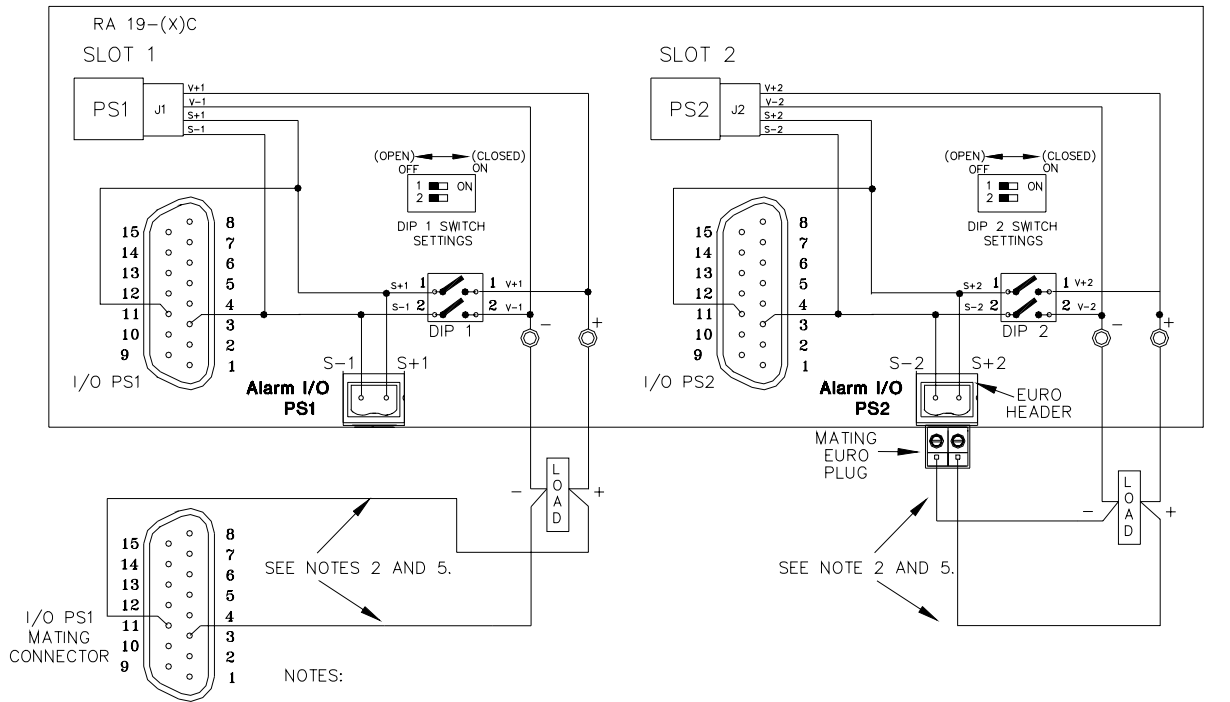

3042915

FIGURE 2-5. INDEPENDENT OPERATION, REMOTE SENSING FOR PS1 AND PS2 USING EXTERNAL WIRING AT I/O MATING CONNECTOR OR EUROBLOCK, SIMPLIFIED DIAGRAM

2.4.2 PARALLEL OPERATION

Up to four identical HSF Power Supplies can be connected in parallel (with or without N+1 redundancy). *Connecting 300W models with 600W models of the same voltage, or 600W models with 1500W models of the same voltage in a parallel configuration is not recommended because differently rated models will not current share.* The impedance of the load wires between each power supply and load should be the same. In addition, multiple RA 19-4C rack adapters that are fully populated with identical HSF power supplies may be paralleled using external wiring at the I/O connectors. *When using HSF 300W and 600W models, the sense lines MUST also be configured (see PAR. 2.4.2.5).*

For a single remote ON-OFF signal to turn off all parallel-connected units, at the I/O mating connectors connect together all +RC pins (pin 15) and connect together all –RC pins (pin 8).

Four things must be considered when configuring the rack adapter for parallel operation:

- VOLTAGE CONTROL
- DC OUTPUT
- CURRENT BALANCING
- SENSE CONNECTIONS (300W and 600W ONLY)

The power leads must be connected in parallel externally by connecting each power supply directly to the load; DAISY CHAIN WIRING IS **NOT PERMITTED**, however bus bars are available as accessories to make these connections when paralleling adjacent slots (refer to Table 1-2).

Parallel-connected power supplies operate with one power supply as the master and the rest as slaves. This can be done using either individual control or group control.

Individual Control. Individual control means that the output voltage of each must be individually adjusted to within 2% of each other. The power supply with the highest voltage will be the master and the rest will be slaves.

Group control. Group control means that the user designates one power supply as the master, and the rest are slaves. Adjusting the output voltage of the master determines the output voltage of the parallel-connected group.

For both individual control and group control, the power supplies can be adjusted either locally, using the front panel adjustment control, or remotely, using either an external voltage or resistance. Since multiple external voltage or resistance sources would be required for individual control, individual control is usually by local (front panel) adjustment of each unit. For both individual and group control, current balancing (also referred to as forced current sharing) is implemented to equalize the load current (see PAR. 2.4.2.4).

2.4.2.1 INDIVIDUAL CONTROL

Refer to Figure 2-6 for connections. Each parallel-connected unit must be adjusted within 2% of each other. The unit with the highest output voltage functions as the master, while the rest are slaves. In the event of a failure of any power supply, the next highest unit will continue to supply the load without interruption, making this configuration ideal for N+1 redundancy.

Refer to applicable HSF manual for HSF DIP switch settings required for local (Vadj control) or remote (external R or V). To adjust output voltage first place the configuration under an operating load. Then monitor the (+) and (-) test points on the front panel with a precision voltmeter. For local control turn the HSF Vadj control to the desired operating value. For remote control adjust the external resistance or voltage source for the desired operating value. Refer to applicable HSF manual for the recommended Adjustment Range of all the HSF Models. Refer to PAR. 2.4.2.4 for current balancing requirements.

Figure 2-6 shows a configuration in which the master is determined by whichever power supply has the highest voltage. In this configuration the output voltage of all power supplies must be set within 2% for current balancing to be in effect. The internal DIP switches, SW1 and SW2, of each HSF module must be configured to allow control of the output voltage by either a) the HSF front panel Vadj control (as shown in Figure 2-6) or b) remote control of the output, either by an external voltage or an external resistance.

This configuration requires that CB (Current Balance) and -COM (negative Common) of all modules be tied together, using either the DIP switches at the rear of the rack adapter, or by wiring the I/O mating connector as shown in Figure 2-6. Wiring of the I/O mating connector allows non-adjacent slots to be connected in parallel. If rack adapter DIP switches are used to connect the RV and -COM lines, positions 9 and 10 of adjacent modules (DIP 2 and DIP 3 in Figure 2-6) must be ON (closed). If external wiring of the I/O connector is used, positions 9 and 10 of DIP switches for adjacent modules (DIP 2 and DIP 3 in Figure 2-6) must be set to OFF (open) and the RV and -COM connections must be wired at the I/O mating connector as shown in Figure 2-6.

NOTE: When connections are made at the I/O mating connector, use shielded wire for connections to RV pins. Match impedance of load wires between each power supply and load by using the same wire lengths and wire sizes.

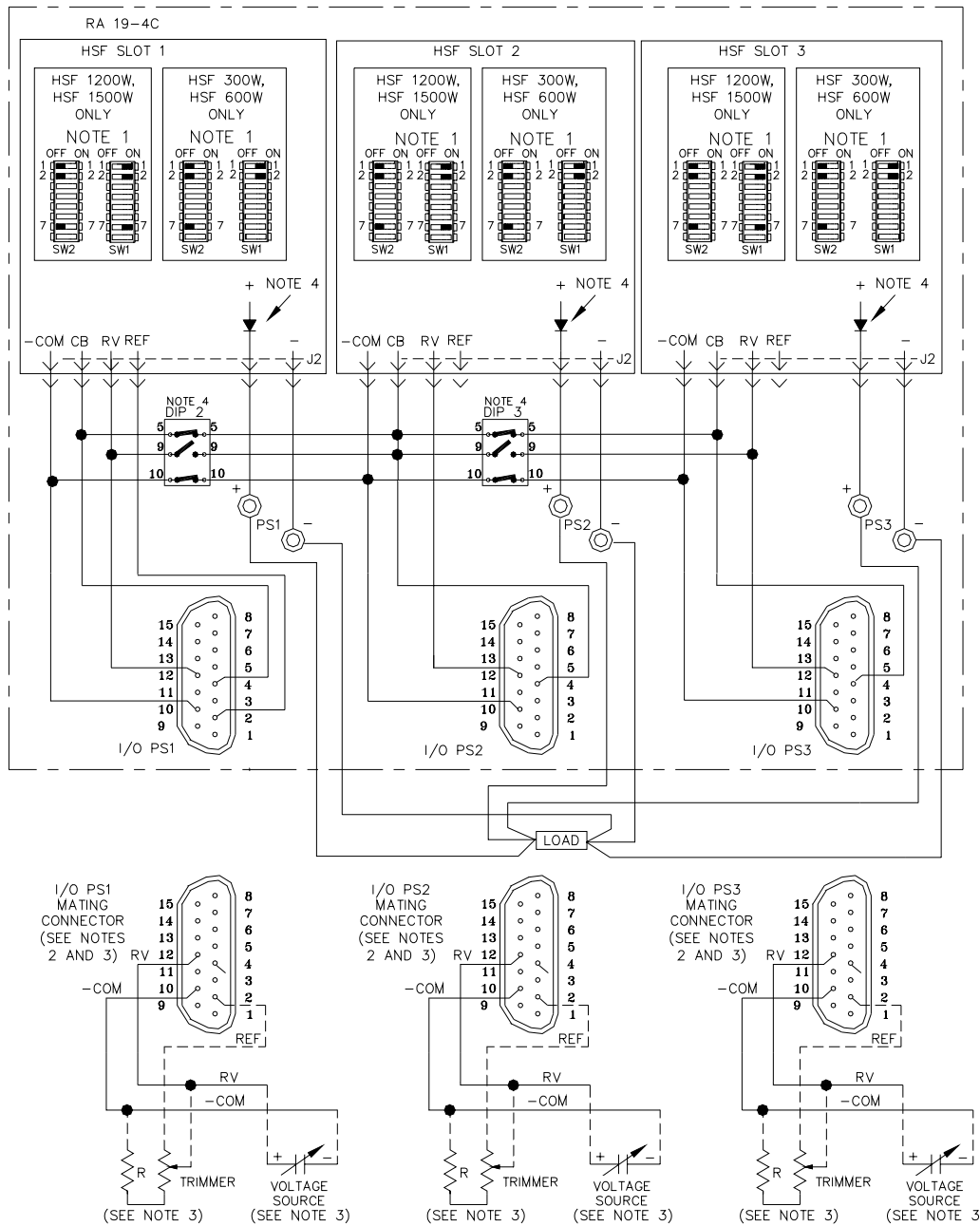

NOTES:

1. USE THESE HSF DIP SWITCH SETTINGS TO ALLOW UNIT WITH HIGHEST VOLTAGE TO BE SELECTED AS MASTER AND ALLOW FRONT PANEL VADJ TO CONTROL OUTPUT VOLTAGE OF ALL POWER SUPPLIES. FOR REMOTE CONTROL OF THE OUTPUT VOLTAGE, SEE NOTE 3.
2. CB AND -COM LINES ARE PARALLELED INTERNALLY VIA RACK ADAPTER DIP 2 AND DIP 3, POSITIONS 5 AND 10, RESPECTIVELY. OR EXTERNAL RESISTANCE).
3. FOR EACH UNIT TO BE CONTROLLED REMOTELY USE I/O MATING CONNECTOR TO CONNECT REMOTE RESISTANCE OR VOLTAGE SOURCE. REFER TO HSF OPERATOR MANUALS FOR DIP SWITCH SETTINGS (REMOTE CONTROL). REFER TO PAR. 2.4.2.1 FOR SETTINGS REQUIRED TO ALLOW OUTPUT VOLTAGE CONTROL OF ALL POWER SUPPLIES TO BE EITHER LOCAL (BY FRONT PANEL VADJ) OR REMOTE (BY EXTERNAL VOLTAGE SOURCE OR RESISTANCE).
4. ISOLATION DIODES ARE PART OF HSF POWER SUPPLY.
5. CONNECTIONS BETWEEN I/O CONNECTORS AND HSF POWER SUPPLIES ARE INTERNAL TO RACK ADAPTER AND ARE SHOWN FOR REFERENCE ONLY.

3043041

FIGURE 2-6. PARALLEL CONNECTION, INDIVIDUAL CONTROL, MASTER-SLAVE, SINGLE LOAD, MASTER DETERMINED BY HIGHEST OUTPUT VOLTAGE

2.4.2.2 GROUP CONTROL

Group control using one power supply designated as the master requires that the power supply designated as the master be adjusted to the desired output voltage. All the other parallel-connected units are slaves that track the output voltage of the master. This configuration can be used to provide easy control of output bus voltage, however it is not truly redundant, since a failure of the master will cause a failure of the parallel-connected system. Failure of a slave reduces the current capacity of the system, but it will continue to function.

For group control requiring a redundant system Kepco recommends configuring all parallel connected units as slaves (see Table 2-3) controlled by a remote voltage. To eliminate a single point failure possibility the remote voltage should have a backup and be connected in parallel to more than one I/O connector.

At the rack adapter I/O connector use a shielded wire 6.6 feet (2M) maximum in length, for connection of REF (pin 15), RV (pin 18), and –COM (pin 12) to the trimmer control or external voltage source (see Figure 2-7 or 2-8).

2.4.2.3 PARALLEL, MASTER SELECTED BY USER, SUPPLYING BALANCED CURRENT TO A SINGLE LOAD

NOTE: For HSF 300W and 600W models, refer to associated power supply Operator Manual for minimum load or output voltage limits needed to avoid “slave idle” or output oscillation (when slave is idle, output is off, no lights are lit, and alarm is set).

Figure 2-7 shows the connection of three power supplies in parallel to a single load. The output voltage of all slave power supplies tracks the master. The master and slaves are determined by the internal DIP switches, SW1 and SW2, of the HSF modules as defined in Table 2-3.

**TABLE 2-3. HSF DIP SWITCH CONFIGURATION FOR GROUP CONTROL
(ALLOWS MASTER TO CONTROL OUTPUT WHILE SLAVES TRACK MASTER)**

MASTER OR SLAVE	HSF DIP SWITCH POSITION (See Note)	HSF 300W, 600W				HSF 1200W, 1500W			
		Vadj Control		External R or V		Vadj Control		External R or V	
		SW2	SW1	SW2	SW1	SW2	SW1	SW2	SW1
MASTER	Position 1 (REF)	OFF	ON	ON	OFF	OFF	ON	ON	OFF
	Position 2 (RV)	ON	ON	ON	OFF	ON	ON	ON	OFF
	Position 7 (COM)	OFF	See Note (2)	OFF	See Note (2)	ON	ON	ON	See Note (2)
SLAVE	Position 1 (REF)	OFF	OFF	OFF	OFF	OFF	OFF	OFF	OFF
	Position 2 (RV)	ON	OFF	ON	OFF	ON	OFF	ON	OFF
	Position 7 (COM)	OFF	See Note (2)	OFF	See Note (2)	ON	OFF	ON	OFF

NOTES:

(1) HSF DIP Switches are located at the rear of each HSF module; refer to appropriate HSF manual for location.

(2) For HSF 600W, set SW1 position 7 to OFF

For HSF 300W, SW1 position 7 allows the DC ON indicator to be powered by an internal auxiliary supply (see HSF 300W Operator Manual for details).

This configuration requires that CB (Current Balance) and RV (Remote Voltage) of all modules be tied together, using either the DIP switches at the rear of the rack adapter, as shown in Figure 2-7, or by wiring the I/O mating connector as shown in Figure 2-8. Wiring of the I/O mating connector allows non-adjacent slots to be connected in parallel.

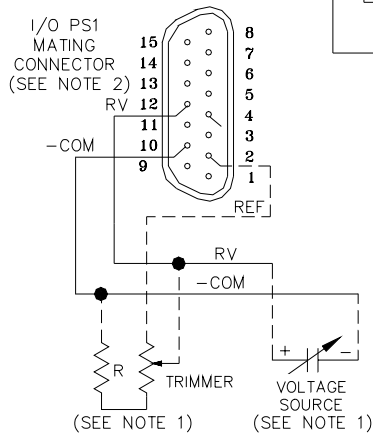
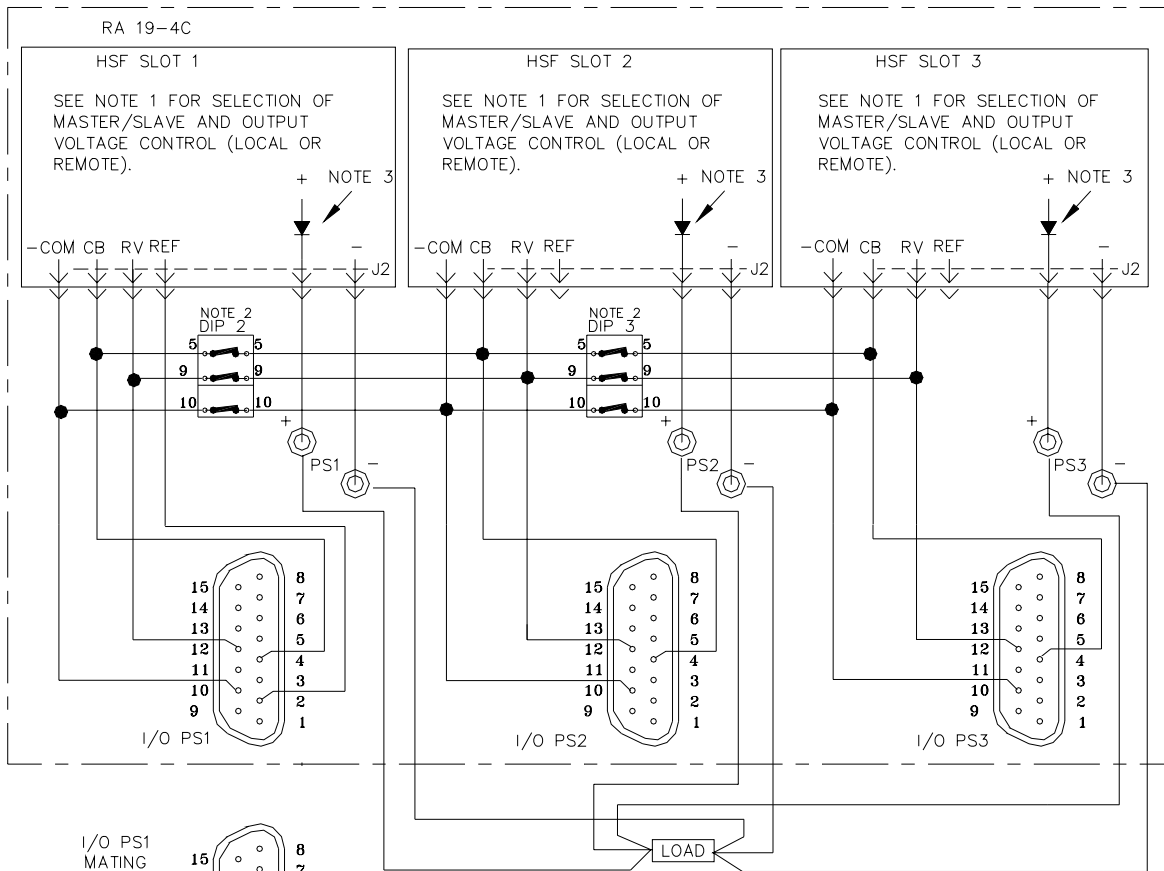

NOTES:

1. REFER TO PAR. 2.4.2.1 AND TABLE 2-3 FOR REQUIREMENTS, INCLUDING HSF DIP SWITCH, SETTINGS REQUIRED TO SELECT MASTER OR SLAVE AND TO ALLOW OUTPUT VOLTAGE CONTROL OF ALL POWER SUPPLIES TO BE EITHER LOCAL (BY FRONT PANEL VADJ) OR REMOTE (BY EXTERNAL VOLTAGE SOURCE OR EXTERNAL RESISTANCE).
2. PARALLEL CONNECTIONS FOR COM, RV AND CB ARE THROUGH DIP SWITCHES; USE I/O MATING CONNECTOR ONLY FOR REMOTE VOLTAGE CONTROL CONNECTIONS. FOR REMOTE VOLTAGE CONTROL USING A DEDICATED MASTER, CONNECT REMOTE RESISTANCE OR VOLTAGE SOURCE ONLY TO MASTER.
3. ISOLATION DIODES ARE PART OF HSF POWER SUPPLY.
4. CONNECTIONS BETWEEN I/O CONNECTORS AND HSF POWER SUPPLIES ARE INTERNAL TO RACK ADAPTER AND ARE SHOWN FOR REFERENCE ONLY.

3043039

FIGURE 2-7. PARALLEL, MASTER-SLAVE, SINGLE LOAD, HSF DIP SWITCHES DEFINE MASTER AND VOLTAGE CONTROL, RV, COM AND CB LINES PARALLELED BY RACK ADAPTER DIP SWITCHES

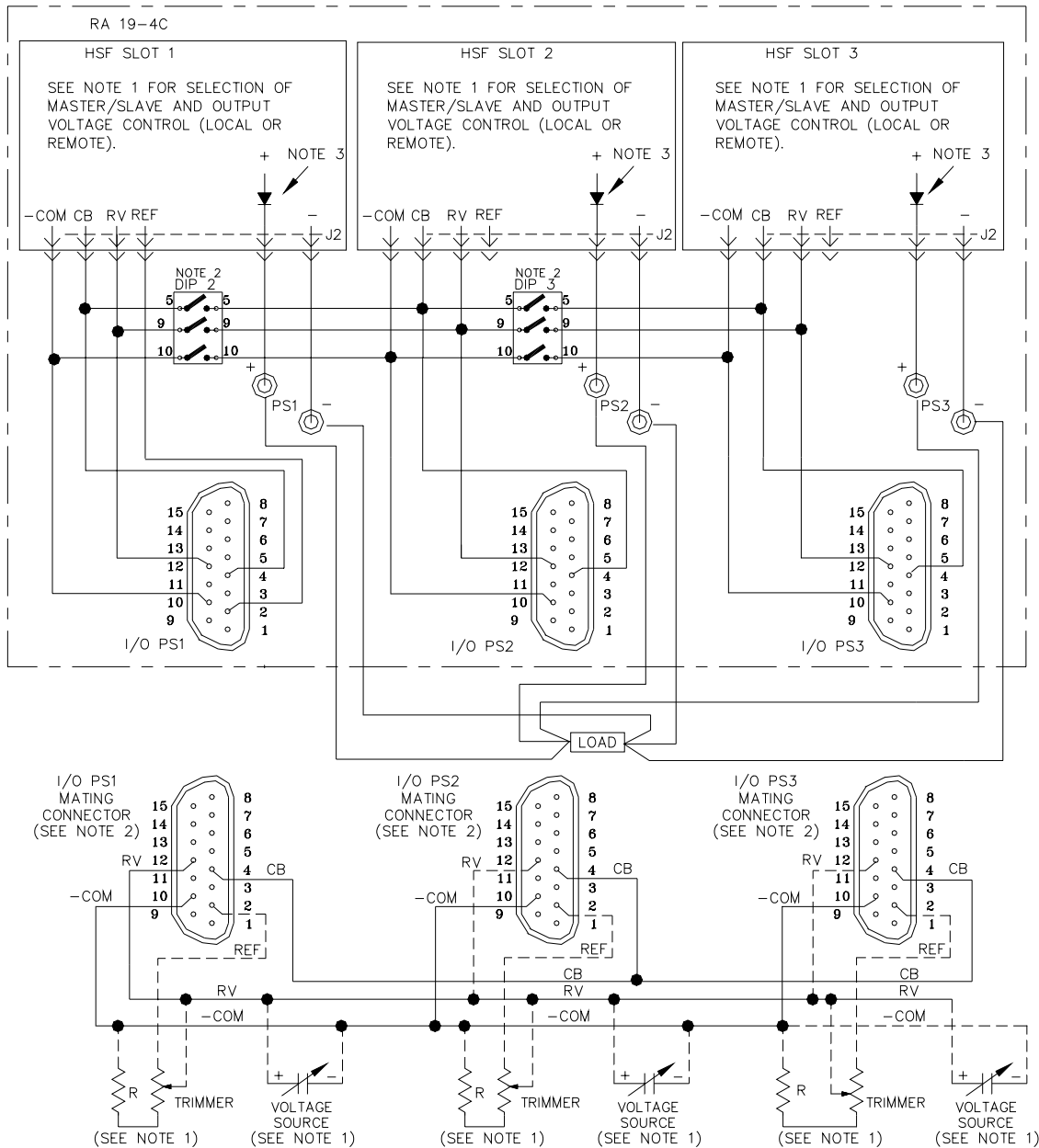

NOTES:

1. REFER TO PAR. 2.4.2.1 AND TABLE 2-3 FOR REQUIREMENTS, INCLUDING HSF DIP SWITCH, SETTINGS REQUIRED TO SELECT MASTER OR SLAVE AND TO ALLOW OUTPUT VOLTAGE CONTROL OF ALL POWER SUPPLIES TO BE EITHER LOCAL (BY FRONT PANEL VADJ) OR REMOTE (BY EXTERNAL VOLTAGE SOURCE OR EXTERNAL RESISTANCE).
2. PARALLEL CONNECTIONS FOR COM, RV AND CB ARE THROUGH I/O MATING CONNECTOR. FOR REMOTE VOLTAGE CONTROL USING A DEDICATED MASTER, CONNECT REMOTE RESISTANCE OR VOLTAGE SOURCE ONLY TO MASTER.
3. ISOLATION DIODES ARE PART OF HSF POWER SUPPLY.
4. CONNECTIONS BETWEEN I/O CONNECTORS AND HSF POWER SUPPLIES ARE INTERNAL TO RACK ADAPTER AND ARE SHOWN FOR REFERENCE ONLY.

3043040

FIGURE 2-8. MASTER-SLAVE, SINGLE LOAD, HSF DIP SWITCHES DEFINE MASTER AND VOLTAGE CONTROL, RV, COM AND CB LINES PARALLELED BY EXTERNAL WIRING AT I/O CONNECTOR

2.4.2.4 CURRENT BALANCING

NOTE: For HSF 300W and 600W models, refer to associated power supply Operator Manual for minimum load or output voltage limits needed to avoid “slave idle” or output oscillation (when slave is idle, output is off, no lights are lit, and alarm is set).

The current equalization with up to four HSF 300W, 600W, 1200W or 1500W units in parallel should be within 20 to 90% of the total output current rating. The output voltage of any Power Supply individually must be within 2% maximum of the other power supply output voltage setting. The expected current sharing is such that the output current variation for each power supply is less than or equal to 10% of each power supply rated output current.

N+1 Redundancy. An N+1 system requires one additional power supply than necessary to supply the load. If one of the parallel-connected units fail, the others will continue to provide power to the load without down time.

When units are configured for N+1 parallel redundant operation, it is desirable for current to be divided equally among the paralleled supplies. When the CB (Current Balancing) lines of paralleled HSF units are connected together, the load current is forced to divide equally between all paralleled units. If one unit fails, the remaining units will continue to supply the load, and the load current will be divided equally among the remaining operating units. The failed unit is automatically isolated from the circuit by a built-in isolation diode.

For parallel operation (see Figures 2-7 or 2-6) the conditions for current equalization are:

$$\frac{\text{Maximum Voltage} - \text{Minimum Voltage}}{\text{Rated Voltage}} = 2\% \quad \text{variation of output voltage in each power supply}$$

The maximum output current: Rated output current of each power supply x (number of power supplies) x (20 to 90 percent).

Variation of output current < ±10 % of each rated output current

To control the output from a single power supply without adjusting each one individually to within 2%, refer to PAR. 2.4.2.3 and Figure 2-7.

2.4.2.5 SENSE CONNECTIONS FOR PARALLEL CONFIGURATIONS (HSF 300W AND 600W MODULES ONLY)

NOTE: HSF 300W and 600W power supply sense lines **MUST** be connected to the respective output terminals; otherwise the power supplies will not work.

For parallel configurations the sense lines must be connected in parallel. This can be accomplished either by using the DIP switches (positions 3 and 4 set to ON) or by setting the DIP switch positions 3 and 4 to OFF and using external wires. When configuring units to work in parallel, the current share bus (PAR. 2.4.2.4) must also be configured.

For local sensing (at the rack adapter) connect the sense lines in parallel using either the DIP switches or external wires, then connect one +S and one –S from the I/O mating connector to the (+) and (-) Output terminals or the corresponding terminals on the bus bars (see Table 1-2) using short jumpers.

For remote sensing (at the load) connect the sense lines in parallel using either the DIP switches or external jumpers to connect the sense lines in parallel, then connect one +S and one –S from the I/O connector to the load using external wires.

For both local and remote sensing Positions 1 and 2 of *each* DIP switch in the parallel configuration must be set to OFF (open); refer to Figure 1-3 to identify the DIP switch associated with a corresponding slot.

See the following paragraphs for more details:

- PAR. 2.4.2.5.1: Parallel configurations using DIP switches to connect the sense lines in parallel and external wires to configure local or remote sensing.
- PAR. 2.4.2.5.2: Parallel configurations using external wires to connect the sense lines in parallel and external wires to configure local or remote sensing.

2.4.2.5.1 PARALLEL CONFIGURATION USING DIP SWITCHES TO CONNECT SENSE LINES IN PARALLEL

Figure 2-9 is a simplified diagram of a typical parallel configuration using local sensing via external wires to connect V(+) to S(+), V(-) to S(-) and DIP switch settings to connect the sense leads in parallel. This configuration requires the following:

1. For each supply in parallel set DIP switch positions 1 and 2 to OFF (open).
2. For each DIP switch between parallel-connected slots (DIP 2), set DIP switch positions 3 and 4 to ON (closed) to connect sense leads in parallel.
3. For each DIP switch between parallel-connected slots configure position 5 to connect the current share bus by referring to PAR. and 2.4.2.4).
4. Configure Positions 6, 7, and 8 (alarms) of each DIP switch per PAR. 2.5.
5. For local sensing connect wire between one I/O mating connector pin 3 (S+) or Euro Mating plug (S+) and corresponding power supply (+) output terminal or bus bar. For remote sensing connect wire between one I/O mating connector pin 3 (S+) or Euro Mating plug (S+) and corresponding load (+) terminal.
6. For local sensing connect wire between one I/O mating connector pin 11 (S-) or Euro Mating plug (S-) and corresponding power supply (-) output terminal or bus bar. For remote sensing connect wire between one I/O mating connector pin 11 (S-) or Euro Mating plug (S-) and corresponding load (-) terminal.

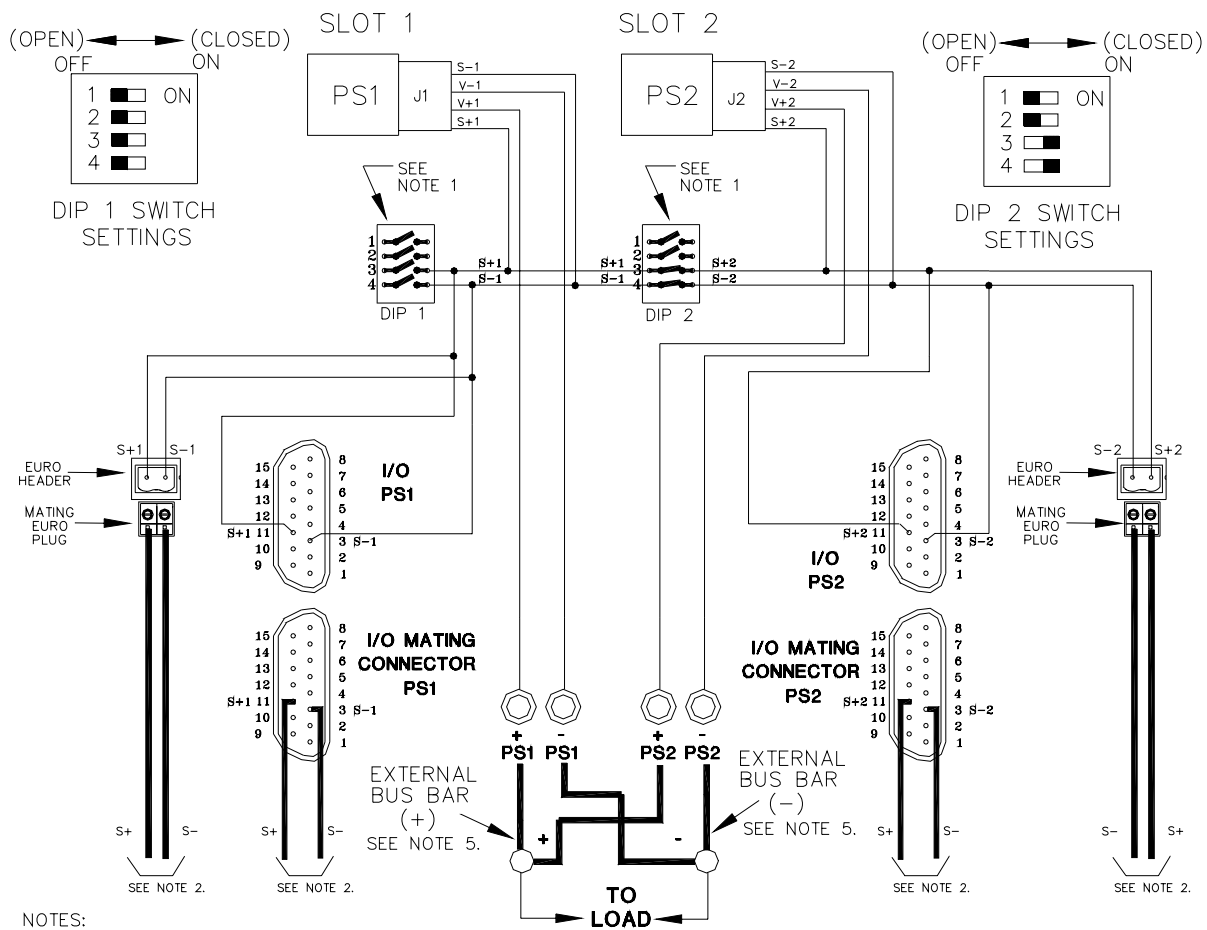

NOTES:

- DIP SWITCH SETTINGS FOR PARALLEL OPERATION :
 - POSITIONS 1 AND 2 OF DIP SWITCHES 1 AND 2 MUST BE SET TO OFF (OPEN).
 - POSITIONS 3 AND 4 OF DIP SWITCH 2 MUST BE SET TO ON (CLOSED).
 - POSITIONS 3 AND 4 OF DIP SWITCH 1 ARE NOT CONNECTED, THEIR SETTING IS IRRELEVANT.
- CONNECT ONLY ONE PAIR OF SENSE LINES (S+, S-) TO EITHER THE (+) AND (-) BUS BAR TERMINALS, RESPECTIVELY, FOR LOCAL SENSING OR TO THE LOAD FOR REMOTE SENSING. SENSE LINE CONNECTIONS MAY FROM EITHER THE I/O MATING CONNECTOR SENSE PINS OR FROM EURO HEADER PINS.
- CONNECTIONS TO I/O CONNECTORS, EURO HEADERS AND DIP SWITCHES ARE INTERNAL AND SHOWN FOR REFERENCE ONLY.
- I/O MATING CONNECTOR VIEWED FROM FRONT (MATING FACE) FOR EASE OF LOCATING CORRESPONDING I/O CONNECTOR PINS.
- FOR PARALLEL CONNECTIONS, DO NOT DAISY CHAIN DC OUTPUTS; CONNECT INDIVIDUAL + AND - OUTPUTS TO THE LOAD.

3042912

FIGURE 2-9. TYPICAL PARALLEL CONNECTIONS USING EXTERNAL WIRES FOR LOCAL/REMOTE SENSING AND DIP SWITCHES TO PARALLEL SENSE WIRES (HSF 300W AND 600W ONLY)

2.4.2.5.2 PARALLEL CONFIGURATIONS USING EXTERNAL WIRES TO CONNECT SENSE LINES IN PARALLEL (HSF 300W AND 600W ONLY)

Figure 2-10 is a simplified diagram of a typical parallel configuration using local or remote sensing via external wires to connect V(+) to S(+), V(-) to S(-) and wires connected to the I/O mating connector to connect the sense leads in parallel. This configuration requires the following:

1. For each supply in parallel set DIP switch positions 1 and 2 to OFF (open).
2. For each DIP switch between parallel-connected slots (DIP 2 in Figure 2-10), set DIP switch positions 3 and 4 to OFF (open) (sense leads will be connected in parallel in steps 5 and 6).
3. For each DIP switch between parallel-connected slots configure position 5 to connect the current share bus by referring to PAR. and 2.4.2.4.
4. Configure Positions 6, 7, and 8 (alarms) of each DIP switch per PAR. 2.5.
5. Connect Sense (+) lines in parallel by connecting wires between pin 3 of each I/O mating connector or between the S+ terminals of the Euro mating plug.
6. Connect Sense (-) lines in parallel by connecting wires between pin 11 of each I/O mating connector or between the S- terminals of the Euro mating plug.
7. For local sensing connect wire between one I/O mating connector pin 3 (S+) or Euro Mating plug (S+) and corresponding power supply (+) output terminal or bus bar. For remote sensing connect wire between one I/O mating connector pin 3 (S+) or Euro Mating plug (S+) and corresponding load (+) terminal.
8. For local sensing connect wire between one I/O mating connector pin 11 (S-) or Euro Mating plug (S-) and corresponding power supply (-) output terminal or bus bar. For remote sensing connect wire between one I/O mating connector pin 11 (S-) or Euro Mating plug (S-) and corresponding load (-) terminal.

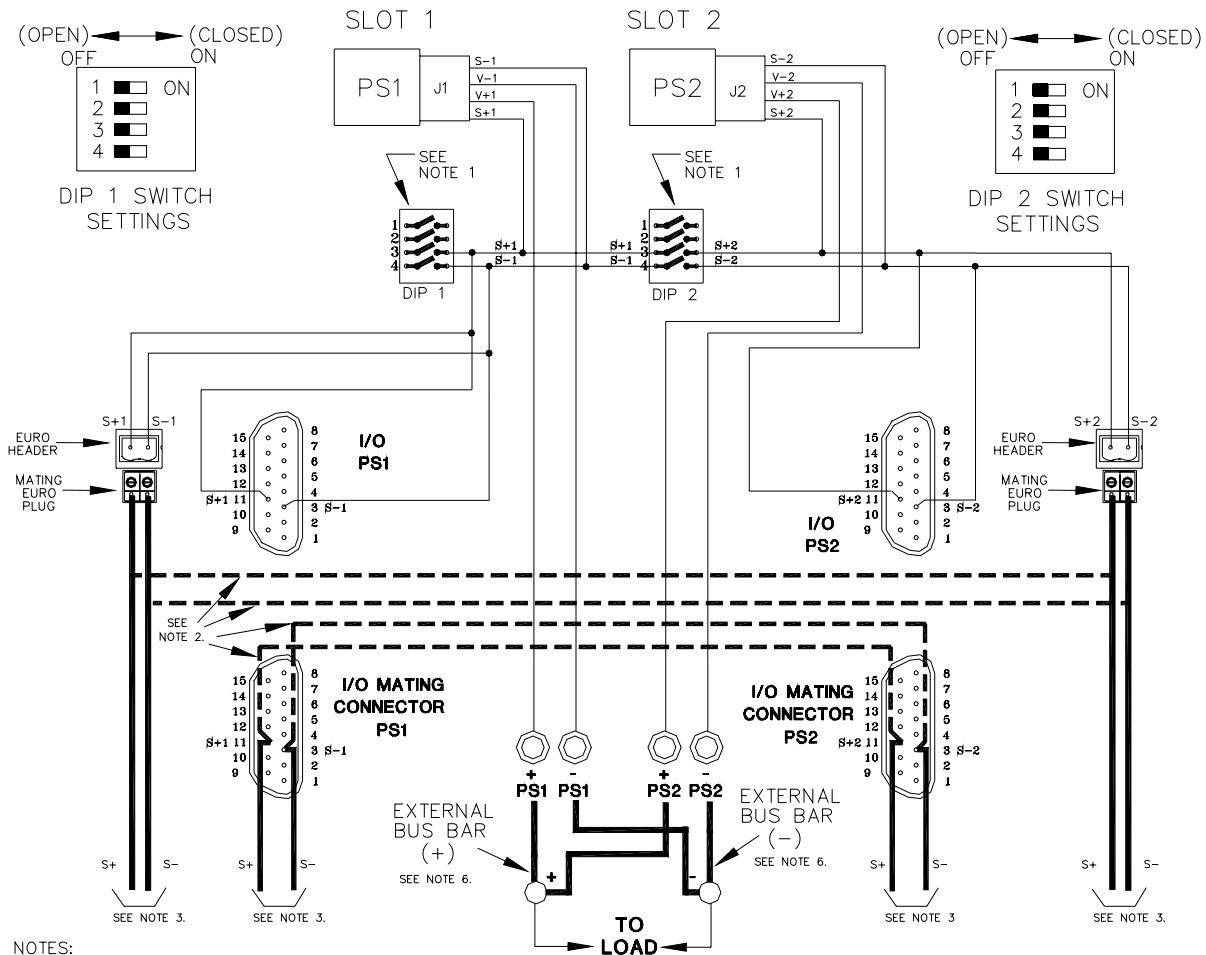

NOTES:

1. DIP SWITCH SETTINGS FOR PARALLEL OPERATION :
 - POSITIONS 1 AND 2 OF DIP SWITCHES 1 AND 2 MUST BE SET TO OFF (OPEN).
 - POSITIONS 3 AND 4 OF DIP SWITCH 2 MUST BE SET TO OFF (OPEN).
 - POSITIONS 3 AND 4 OF DIP SWITCH 1 ARE NOT CONNECTED, THEIR SETTING IS IRRELEVANT.
2. PARALLEL SENSE LINES BY CONNECTING S+ AND S- AS SHOWN, USING EITHER THE MATING I/O CONNECTOR OR THE MATING EURO PLUG.
3. CONNECT ONLY ONE PAIR OF SENSE LINES (S+, S-) TO EITHER THE (+) AND (-) BUS BAR TERMINALS, RESPECTIVELY, FOR LOCAL SENSING OR TO THE LOAD FOR REMOTE SENSING. CONNECTIONS MUST BE FROM THE SAME CONNECTOR USED TO PARALLEL THE CONNECTIONS, EITHER THE MATING I/O CONNECTOR OR THE MATING EURO PLUG.
4. CONNECTIONS TO I/O CONNECTORS, EURO HEADERS AND DIP SWITCHES ARE INTERNAL AND SHOWN FOR REFERENCE ONLY.
5. I/O MATING CONNECTOR VIEWED FROM FRONT (MATING FACE) FOR EASE OF LOCATING CORRESPONDING I/O CONNECTOR PINS.
6. FOR PARALLEL CONNECTIONS, DO NOT DAISY CHAIN DC OUTPUTS; CONNECT INDIVIDUAL + AND - OUTPUTS TO THE LOAD.

3042913

FIGURE 2-10. TYPICAL PARALLEL CONNECTIONS USING EXTERNAL WIRES FOR LOCAL/REMOTE SENSING AND I/O MATING CONNECTOR JUMPERS TO PARALLEL SENSE WIRES (HSF 300W AND 600W ONLY)

2.4.3 SERIES CONNECTION

HSF power supplies may be connected in series to obtain higher output voltages. The RA 19-4C rack adapter is designed to safely handle a maximum output voltage of 500 Volts; contact Kepeco Applications Engineering for additional information. The power supply with the lowest rated value of maximum current establishes the maximum load current allowed. Series configurations can only be accomplished by **external wiring** of the I/O mating connector.

For series operation, connect (+) and (–) terminals at the DC OUTPUT terminal block of power supplies to be connected in series. Bus bars are available as accessories to make these connections when connecting adjacent slots in series (refer to Table 1-2).

The DC OUTPUT + terminal of one supply must be connected to DC OUTPUT – terminal of the next supply. Each Power Supply in series must be protected by a diode connected in parallel with the output as shown in Figure 2-11. The diode protects against reverse voltages. For convenience, bus bars are available as accessories to connect adjacent slots in series (refer to Table 1-2). The bus bars can also serve as heat sinks for the diodes (see Figure 2-21). Protection diodes must conform to the following specifications:

- $V_{REV} > 2 \times V_{NOM} \times N$ where V_{NOM} is the output voltage of the HSF power supply and N is the number of power supplies connected in series.
- $I_{FWD} > 1.5 \times I_{NOM}$ where I_{NOM} is the output current of the HSF power supply.

Rack adapter DIP switches positions 1 through 5 must be set to OFF (open) on all DIP switches between series-connected modules (refer to Figure 1-5).

Table 2-4 lists the settings for the HSF DIP switches required to configure HSF power supplies to use either local or remote control.

TABLE 2-4. HSF DIP SWITCH CONFIGURATION FOR VOLTAGE CONTROL OF MULTIPLE UNITS IN SERIES

HSF DIP SWITCH POSITION (See Note)	HSF 300W, 600W				HSF 1200W, 1500W			
	Vadj Control		External R or V		Vadj Control		External R or V	
	SW2	SW1	SW2	SW1	SW2	SW1	SW2	SW1
Position 1 (REF)	OFF	ON	ON	OFF	OFF	ON	ON	OFF
Position 2 (RV)	OFF	ON	ON	OFF	OFF	ON	ON	OFF
Position 7 (COM)	OFF	See Note (2)	ON	See Note (2)	OFF	ON	ON	OFF

NOTES:

- (1) HSF DIP Switches are located at the rear of each HSF module; refer to appropriate HSF manual for location.
- (2) For HSF 600W, set SW1 position 7 to OFF
For HSF 300W, SW1 position 7 allows the DC ON indicator to be powered by an internal auxiliary supply (see HSF 300W Operator Manual for details).

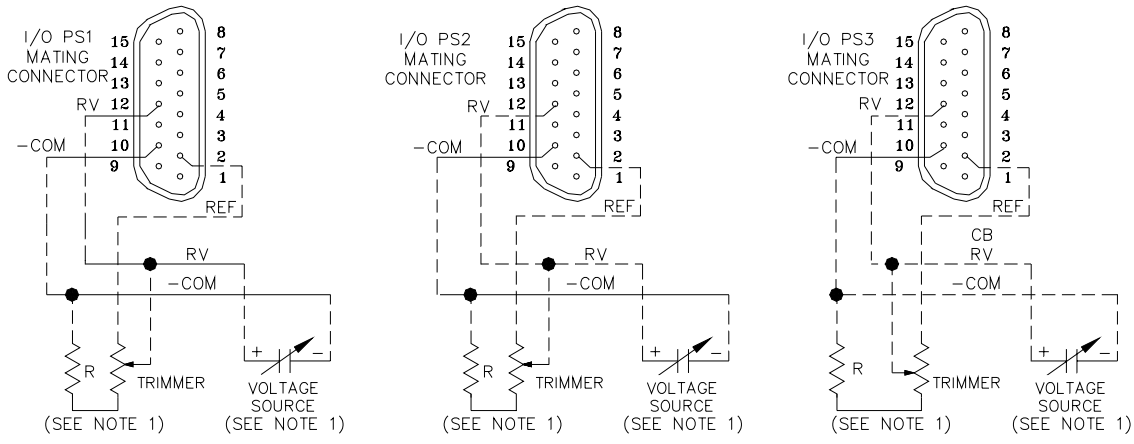
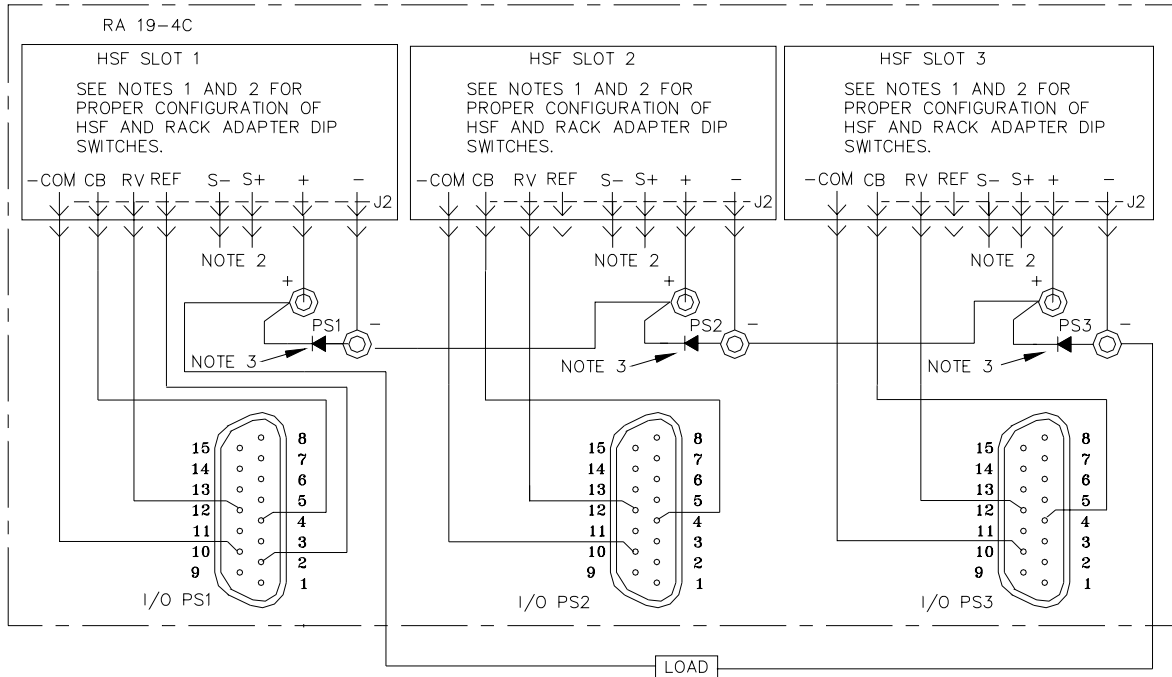

NOTES:

1. REFER TO TABLE 2-4 FOR HSF DIP SWITCH SETTINGS REQUIRED TO ALLOW OUTPUT VOLTAGE CONTROL OF ALL POWER SUPPLIES TO BE EITHER LOCAL (BY FRONT PANEL VADJ) OR REMOTE (BY EXTERNAL VOLTAGE SOURCE OR EXTERNAL RESISTANCE).
2. RACK ADAPTER DIP SWITCHES 1, 2, AND 3 MUST BE SET AS FOLLOWS:
POSITIONS 1, 2: ON (LOCAL SENSING ENABLED)
POSITIONS 3, 4, 5, 9 AND 10: OFF
3. PROTECTION DIODES ARE REQUIRED.
4. CONNECTIONS BETWEEN I/O CONNECTORS AND HSF POWER SUPPLIES ARE INTERNAL TO RACK ADAPTER AND ARE SHOWN FOR REFERENCE ONLY.

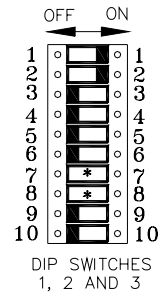

* DEPENDS ON ALARM CONFIGURATION, SEE TABLE 2-2.

3043042

FIGURE 2-11. SERIES CONNECTION

2.5 ALARM CONFIGURATIONS

The HSF Power Supplies each provide a normally closed (N.C.) and normally open (N.O.) line referenced to common (COM) for use as an alarm at the users discretion. The N.C. line opens upon failure, the N.O. line closes upon failure. The RA 19-4C is configured at the factory for independent operation of these lines. It is possible to configure these alarm lines to allow multiple power supplies to provide a failure indication using the N.O. (close on failure) lines, N.C (open on failure) lines, or both. Each alarm circuit can be configured in two ways: either by rear panel DIP switches or by external wiring of the I/O mating connector. Use external wiring of the I/O mating connector if DIP switch specifications noted in the following CAUTION will be exceeded.

CAUTION: The user is responsible for ensuring that the alarm circuit does not exceed the HSF alarm relay switching specifications: 1A @ 30V d-c or 0.5A @ 125V a-c. If the alarm circuit is configured using the rear panel DIP switches, the user is responsible for ensuring that the alarm circuit does not exceed DIP switch specifications: 100mA, 50V d-c, maximum.

2.5.1 N.O. ALARM LINE (CLOSE ON FAILURE)

The N.O. and COM line of each HSF supply provide a closed contact (short circuit) upon failure. To configure multiple power supplies so that a failure of any supply produces a failure indication, it is necessary to connect the N.O. lines in parallel and the COM lines in parallel. The following paragraphs describe three ways to accomplish this:

- Use the rear panel DIP switches to make the connections (PAR. 2.5.1.1).
- Use external connections from the I/O mating connectors (PAR. 2.5.1.2).
- Use external connections from the Alarm I/O terminal blocks (PAR. 2.5.1.1).

2.5.1.1 CLOSE ON FAILURE USING REAR PANEL DIP SWITCHES

Close on failure for multiple power supplies can be accomplished by setting DIP switch positions 6 and 7 to ON (closed). associated with each adjacent slot included in the alarm circuit. For example, for PS1 and PS2, set DIP switch 2, positions 6 and 7 to ON (closed). The failure indication (short circuit) will be present across both N.O.1 and COM1, and N.O.2 and COM2. Figure 2-12 is a simplified diagram illustrating a close on failure alarm configuration for four power supplies using rear panel DIP switches.

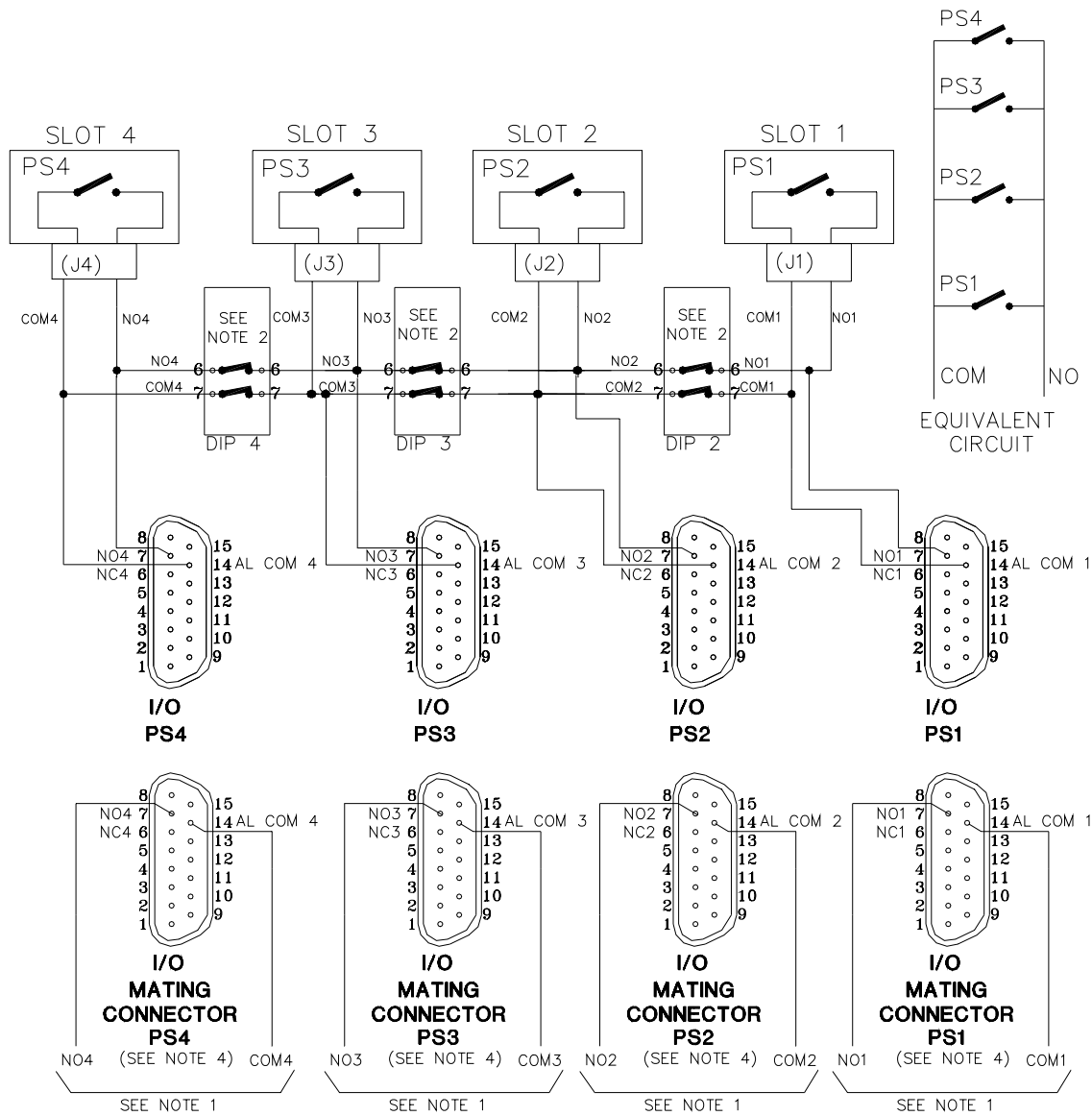

NOTES:

1. USE ANY PAIR OF NO() AND COM() LINES FOR CLOSE ON FAILURE ALARM.
2. SET ALL ASSOCIATED DIP SWITCHES, POSITIONS 6 AND 7, TO ON (CLOSED).
3. CONNECTIONS TO I/O CONNECTOR ARE INTERNAL AND SHOWN FOR REFERENCE ONLY.
4. I/O MATING CONNECTOR VIEWED FROM FRONT (MATING FACE) FOR EASE OF LOCATING CORRESPONDING I/O CONNECTOR PINS.

3042850

FIGURE 2-12. TYPICAL CLOSE ON FAILURE ALARM CONFIGURATION USING REAR PANEL DIP SWITCHES WITH OUTPUT FROM I/O MATING CONNECTOR, SIMPLIFIED DIAGRAM

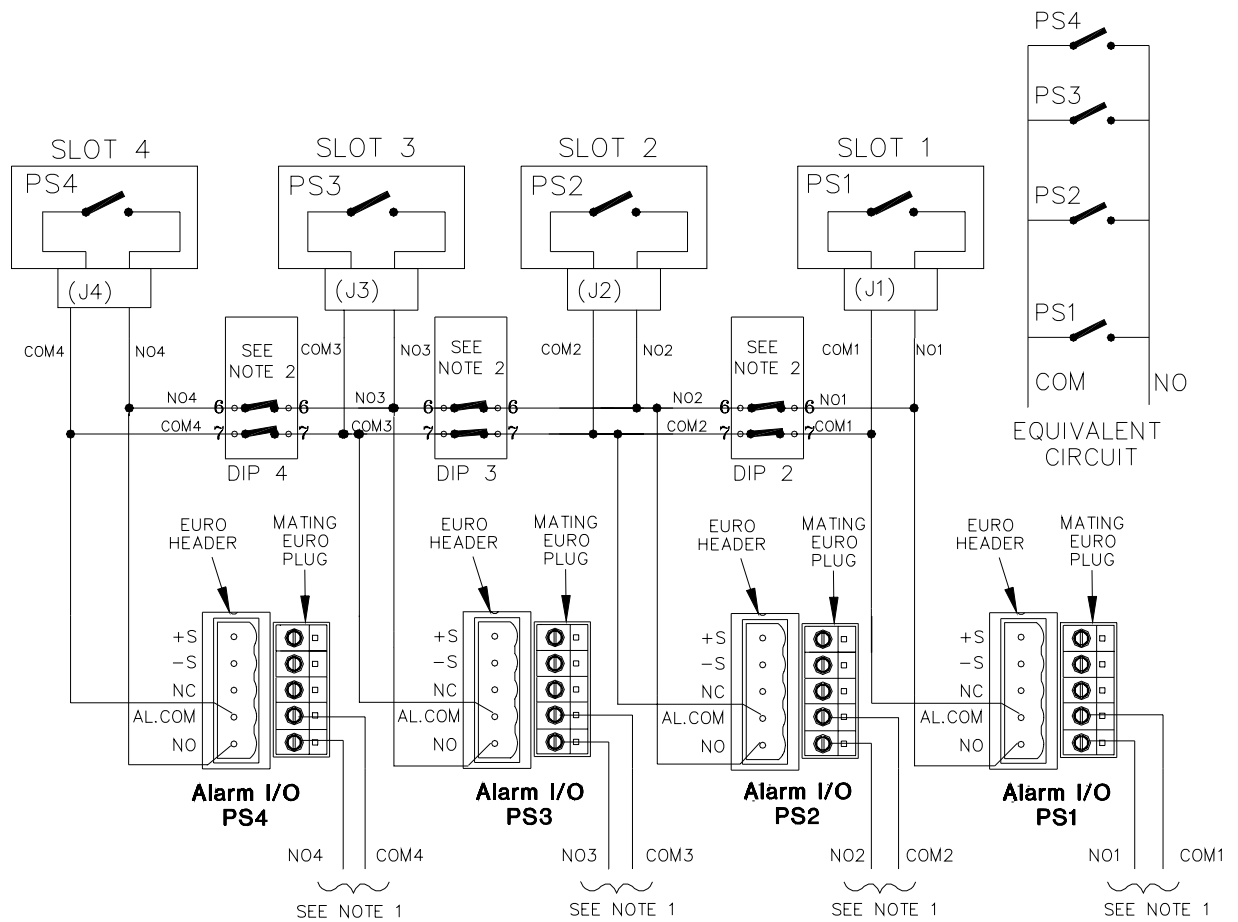

NOTES:

1. USE ANY PAIR OF NO() AND COM() LINES FOR CLOSE ON FAILURE ALARM.
2. SET ALL ASSOCIATED DIP SWITCHES, POSITIONS 6 AND 7, TO ON (CLOSED).
3. CONNECTIONS TO I/O CONNECTOR ARE INTERNAL AND SHOWN FOR REFERENCE ONLY.

3042901

FIGURE 2-13. TYPICAL CLOSE ON FAILURE ALARM CONFIGURATION USING REAR PANEL DIP SWITCHES, WITH OUTPUT FROM ALARM I/O TERMINAL BLOCKS, SIMPLIFIED DIAGRAM

2.5.1.2 CLOSE ON FAILURE USING EXTERNAL WIRING AT I/O MATING CONNECTOR

Close on failure for multiple power supplies can be accomplished by wiring N.O. and COM in parallel at the I/O mating connector. DIP switches associated with slots included in the alarm circuit must have positions 6 and 7 set to OFF (open). The failure indication (short circuit) will be present across any pair of N.O. and COM lines. Figure 2-14 is a simplified diagram illustrating a close on failure alarm configuration for four power supplies using external wiring at the I/O mating connector.

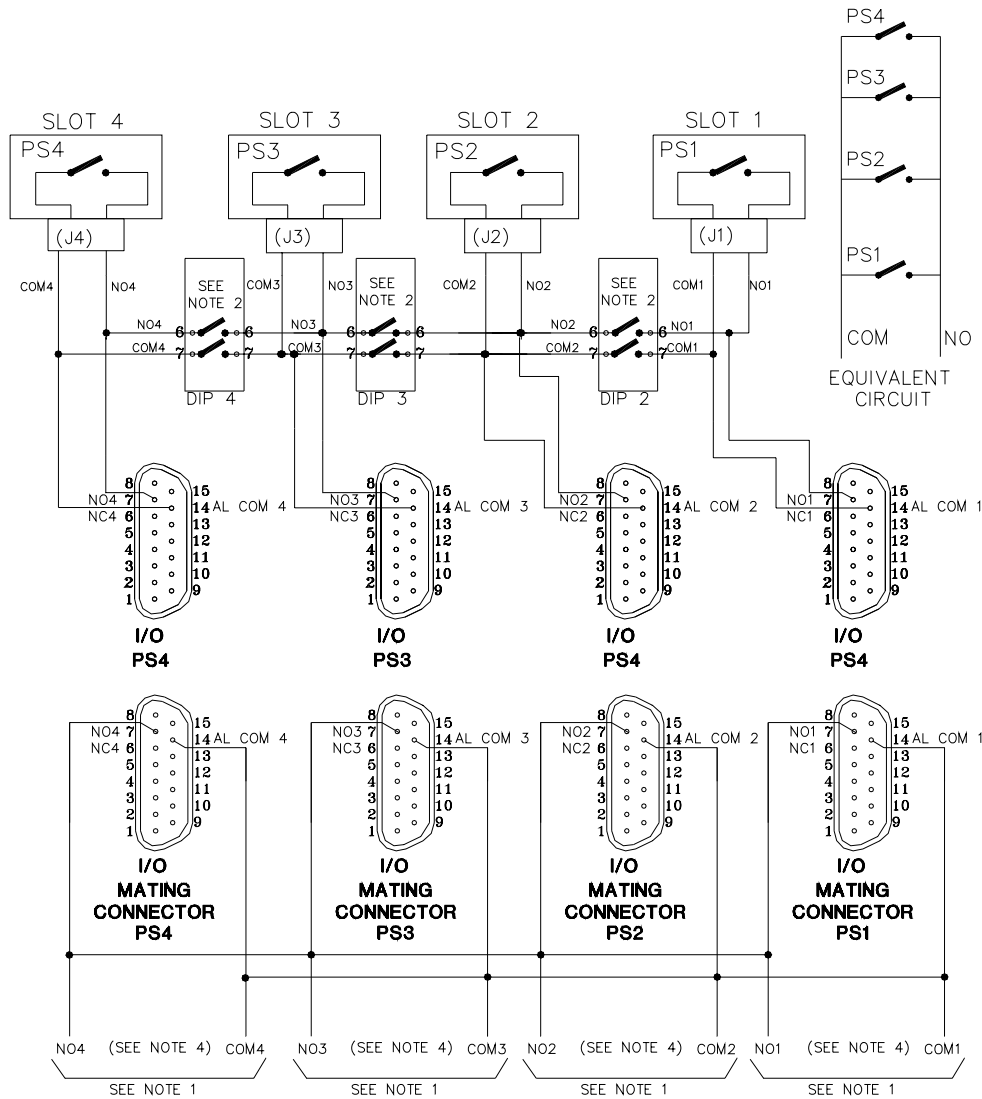

3042851

FIGURE 2-14. CLOSE ON FAILURE ALARM CONFIGURATION USING EXTERNAL WIRING AT I/O MATING CONNECTOR, SIMPLIFIED DIAGRAM

2.5.1.3 CLOSE ON FAILURE USING EXTERNAL WIRING AT ALARM I/O TERMINAL BLOCK

Close on failure for multiple power supplies can be accomplished by wiring N.O. and COM in parallel at the Alarm I/O terminal block. DIP switches associated with slots included in the alarm circuit must have positions 6 and 7 set to OFF (open). The failure indication (short circuit) will be present across any pair of N.O. and COM lines. Figure 2-15 shows a close on failure alarm configuration for four power supplies using external wiring at the Alarm I/O terminal blocks.

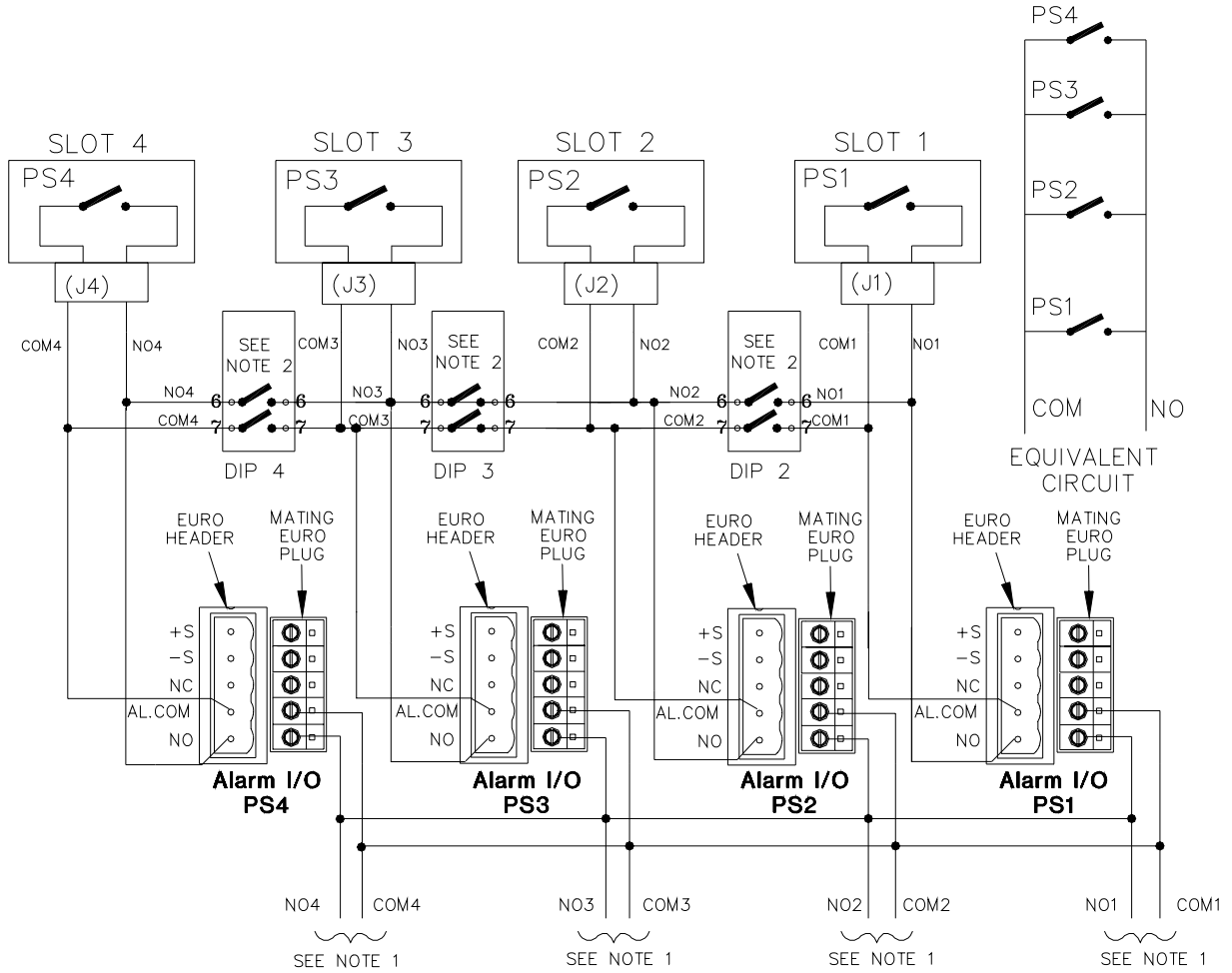

FIGURE 2-15. CLOSE ON FAILURE ALARM CONFIGURATION USING EXTERNAL WIRING AT ALARM I/O TERMINAL BLOCK, SIMPLIFIED DIAGRAM

2.5.2 N.C. ALARM LINE (OPEN ON FAILURE)

The N.C. and COM line of each HSF supply provide an open contact (open circuit) upon failure. To configure multiple power supplies so that a failure of any supply produces a failure indication, it is necessary to connect the N.C. line with the COM line of the next power supply, so the alarm line is connected in series.

2.5.2.1 OPEN ON FAILURE USING REAR PANEL DIP SWITCHES

The open on failure alarm for multiple power supplies is accomplished by setting the associated DIP switch, position 8, to ON (closed) for each slot included in the alarm circuit as indicated in Figure 2-16. Setting DIP switch position 8 to ON (closed) connects the N.C. line to the COM line of the adjacent power supply. Figure 2-16 illustrates an open on failure alarm configuration for four power supplies where the alarm connections are made through the rear panel DIP switches and the alarm signals are applied to the user's alarm circuit via the I/O connector. Figure 2-17 is the same, except alarm signals are available at the Alarm I/O Terminal Blocks.

CAUTION: The user is responsible for ensuring that the alarm circuit does not exceed DIP switch specifications: 100mA, 50V d-c, maximum.

To configure PS1, PS2, PS3 and PS4 as open on failure, set position 8 of DIP switches DIP 2, DIP 3, and DIP 4 to ON (closed). The failure indication (open circuit) will be present across N.C.4 and COM 1.

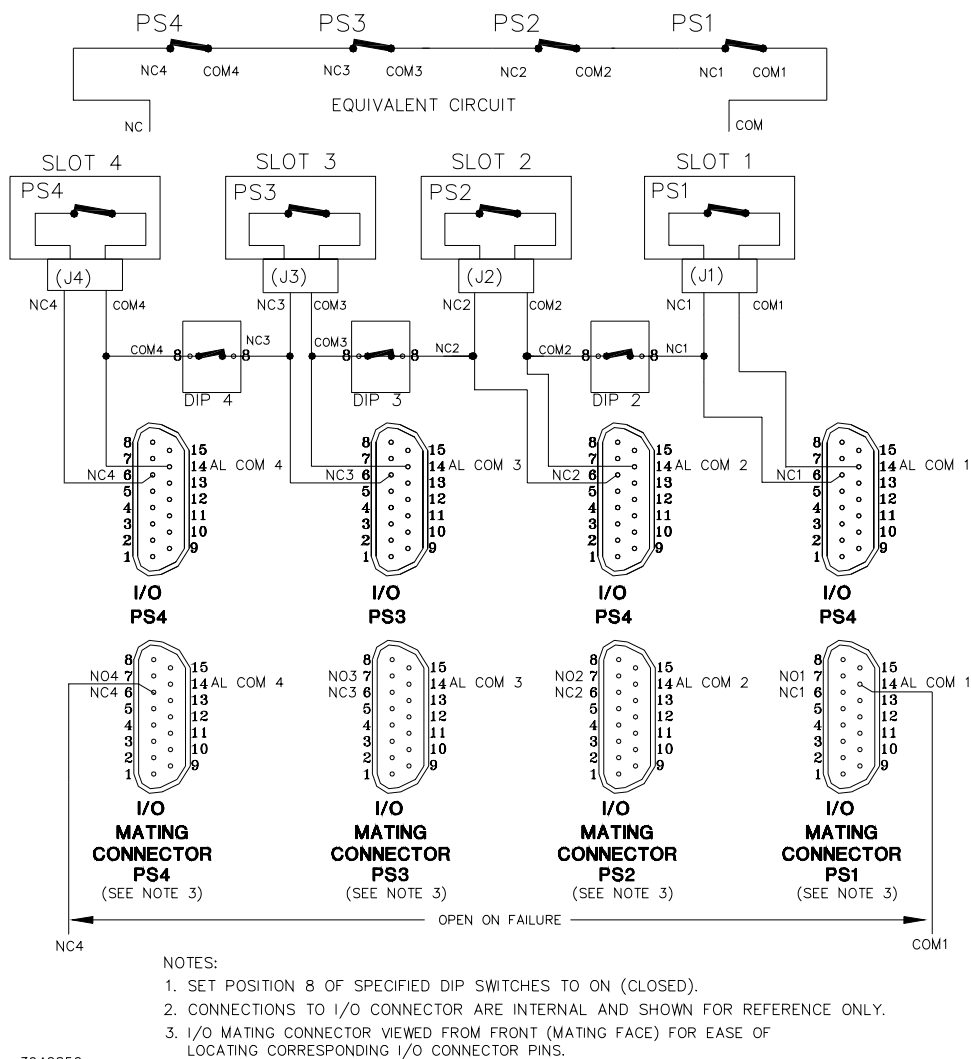
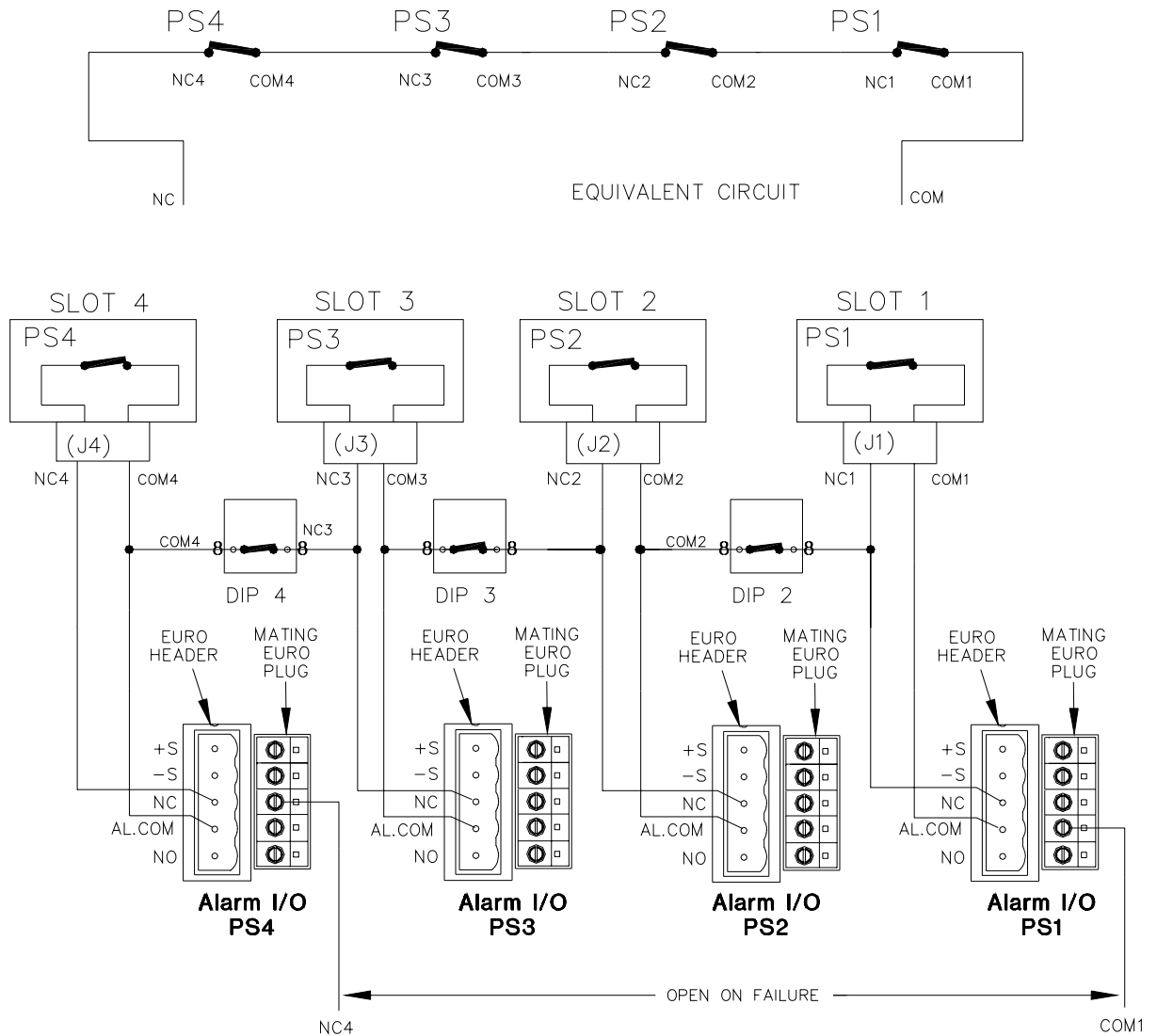

FIGURE 2-16. TYPICAL OPEN ON FAILURE ALARM CONFIGURATION USING REAR PANEL DIP SWITCHES WITH OUTPUT FROM I/O MATING CONNECTOR, SIMPLIFIED DIAGRAM



NOTES:

1. SET POSITION 8 OF SPECIFIED DIP SWITCHES TO ON (CLOSED).
2. CONNECTIONS FROM I/O CONNECTORS AND DIP SWITCHES TO ALARM I/O TERMINAL BLOCKS ARE INTERNAL AND SHOWN FOR REFERENCE ONLY.

FIGURE 2-17. TYPICAL OPEN ON FAILURE ALARM CONFIGURATION USING REAR PANEL DIP SWITCHES WITH OUTPUT FROM ALARM I/O TERMINAL BLOCKS, SIMPLIFIED DIAGRAM

2.5.2.2 OPEN ON FAILURE USING EXTERNAL WIRING OF I/O MATING CONNECTOR

Figure 2-18 illustrates an open on failure alarm configuration using external wiring of the I/O mating connectors for four power supplies. It is necessary to set DIP switch position 8 to OFF (open) for each slot included in the open on failure alarm circuit.

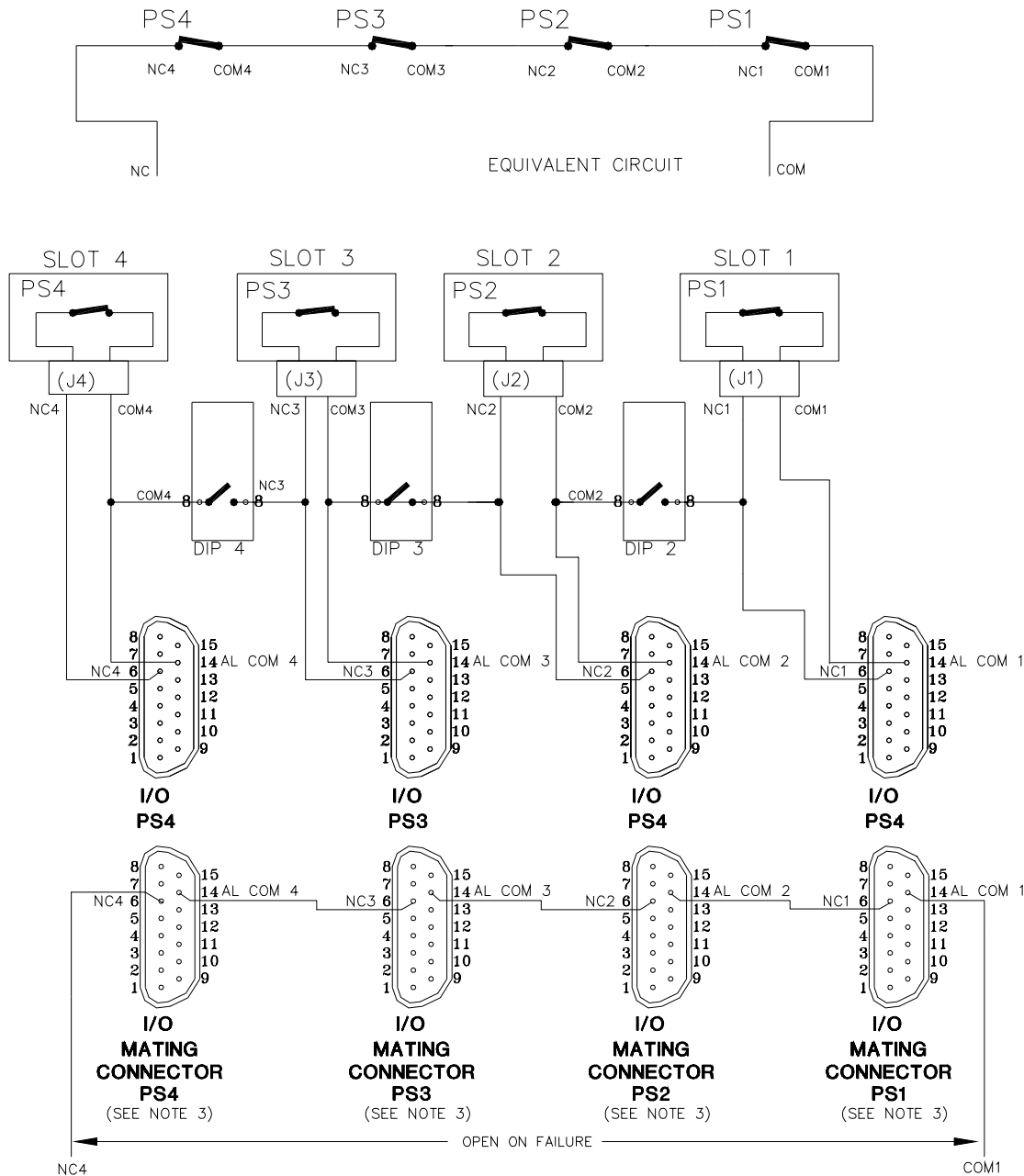

NOTES:

1. SET POSITION 8 OF SPECIFIED DIP SWITCHES TO OFF (OPEN).
2. CONNECTIONS TO I/O CONNECTOR ARE INTERNAL AND SHOWN FOR REFERENCE ONLY.
3. I/O MATING CONNECTOR VIEWED FROM FRONT (MATING FACE) FOR EASE OF LOCATING CORRESPONDING I/O CONNECTOR PINS.

3042853

FIGURE 2-18. OPEN ON FAILURE ALARM CONFIGURATION USING EXTERNAL WIRING AT I/O MATING CONNECTOR, SIMPLIFIED DIAGRAM

2.5.2.3 OPEN ON FAILURE USING EXTERNAL WIRING OF I/O ALARM TERMINAL BLOCKS

Figure 2-18 illustrates an open on failure alarm configuration using external wiring of the I/O mating connectors for four power supplies. It is necessary to set DIP switch position 8 to OFF (open) for each slot included in the open on failure alarm circuit.

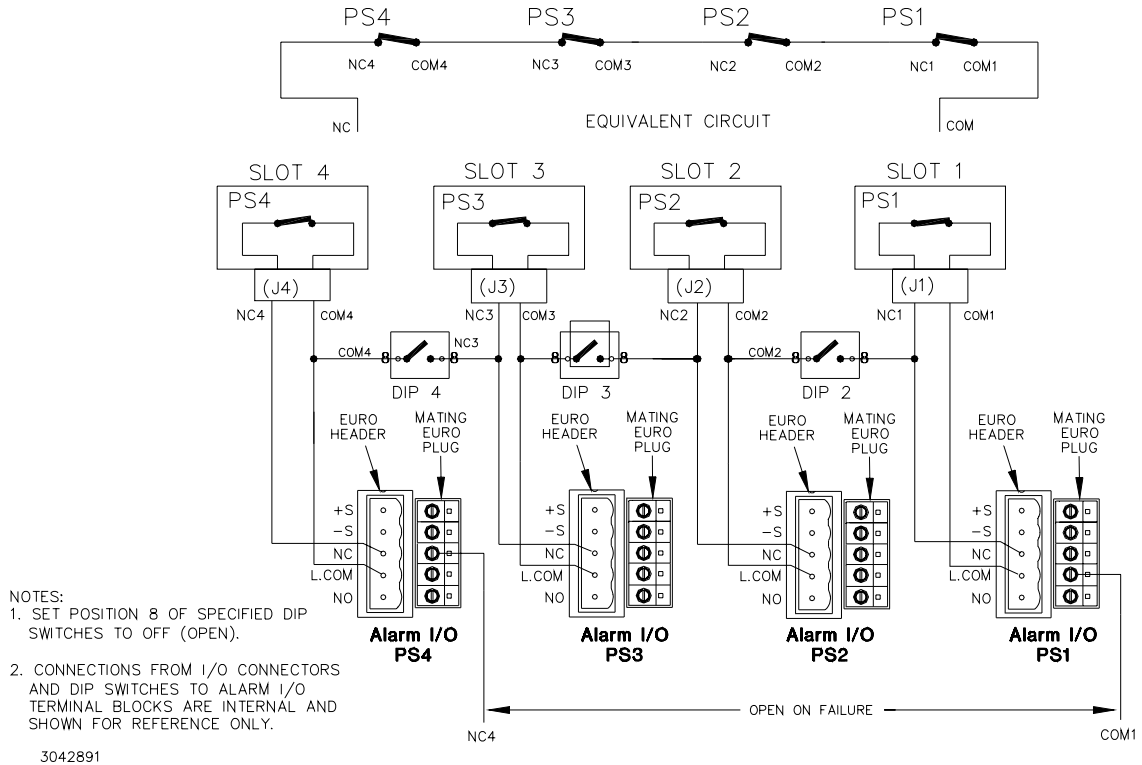

FIGURE 2-19. OPEN ON FAILURE ALARM CONFIGURATION USING EXTERNAL WIRING AT I/O ALARM TERMINAL BLOCKS, SIMPLIFIED DIAGRAM

2.6 TERMINATIONS

All input, output and control terminations are located on the rear panel of the rack adapter (see Figure 1-4).

2.7 COOLING

The HSF power supplies installed in the rack adapter are maintained within their operating temperature range by means of cooling fans within the power supplies. ALL OPENINGS AROUND THE RACK ADAPTER CASE MUST BE KEPT CLEAR OF OBSTRUCTION TO ENSURE PROPER AIR CIRCULATION. Care must be taken that the ambient temperature, which is the temperature of the air immediately surrounding the rack adapter, does not rise above the specified limits for the operating load conditions of the installed HSF power supplies. Kepco recommends providing additional space above and below the rack adapter where possible when the rack adapter is fully populated.

2.8 INSTALLATION (Refer to “Mechanical Outline Drawing,” Figure 1-6.)

The rack adapter mounts directly to EIA-RS 310D standard 19" racks via the two mounting ears; two screws are required per mounting ear for proper support.

CAUTION

RACK ADAPTER SHOULD BE MOUNTED BEFORE INSTALLING POWER SUPPLIES.

Provide adequate clearance around case and ensure that the temperature immediately surrounding the unit does not exceed the maximum specified ambient temperature for the operating conditions of the installed power supplies. For severe shock or vibration environments, see NOTE to PAR. 2.9 below.

2.8.1 INSTALLING OPTIONAL PROTECTIVE COVER (Refer to Figure 2-20.)

A clear plastic cover (Kepco P/N 137-0145) is available as an accessory to protect the rear terminals against accidental contact. Four standoffs (minimum) (Kepco P/N 104-0385) are required for installation.

1. Remove screws and cable clamps as necessary from mounting points “A” (see Figure 2-20). A minimum of four standoffs must be installed. Save all screws and clamps removed.
2. Choose standoff locations to accommodate cable routing and install standoffs at mounting points A (Figure 2-20). Use of suitable thread-lock adhesive on standoff threads is recommended. If cable clamps need to be reused, use standoff to secure clamp to backplate.
3. Insert ten protective cover tabs (three each at top and bottom and two at each side) into corresponding backplate slots. Rectangular cutouts are provided at the edge of the protective cover for cable exit. Round (9/16 in. diameter) holes are provided for strain relief/cable saddle clamps.
4. Peel and remove scratch-resistant film from protective cover.
5. Secure protective cover to standoffs using screws removed in step 1.

2.8.2 INSTALLING OPTIONAL BUS BAR.

Bus bars which connect output terminals for parallel or series operation are available as accessories (see Table 1-2).

1. Remove and save the hex screw and washer from each output terminal to be connected together (bus bars can only be connected to terminals of adjacent slots).

CAUTION: Failure to remove cable clamp can result in the clamp being crushed between backplate and bus bar, causing the output to be shorted to ground.

2. Remove any cable clamps from backplate that maybe covered by the bus bar, or interfere with bus bar installation.
3. Install bus bar across applicable terminals and secure it as shown with the previously removed hardware. See Figure 2-20 for parallel, or Figure 2-21 for series connections.
4. Connect output cables to bus bar studs using hex nut (see Table 1-2).

CAUTION: Ensure current does not exceed 100 Amperes per stud.

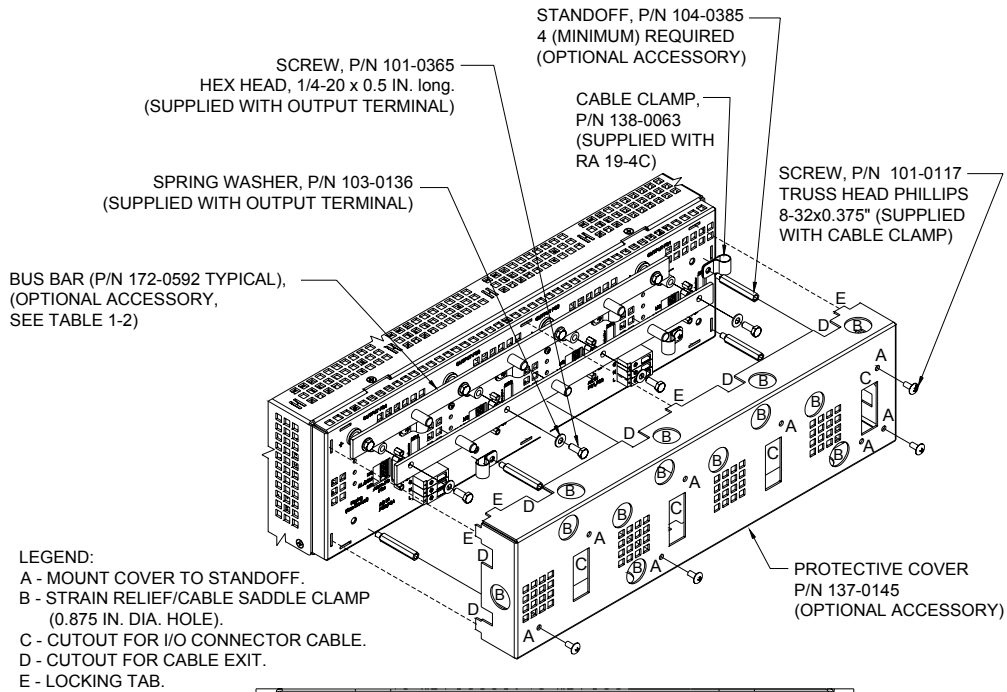

3043095

FIGURE 2-20. OPTIONAL PROTECTIVE COVER OR PARALLEL BUS BAR INSTALLATION

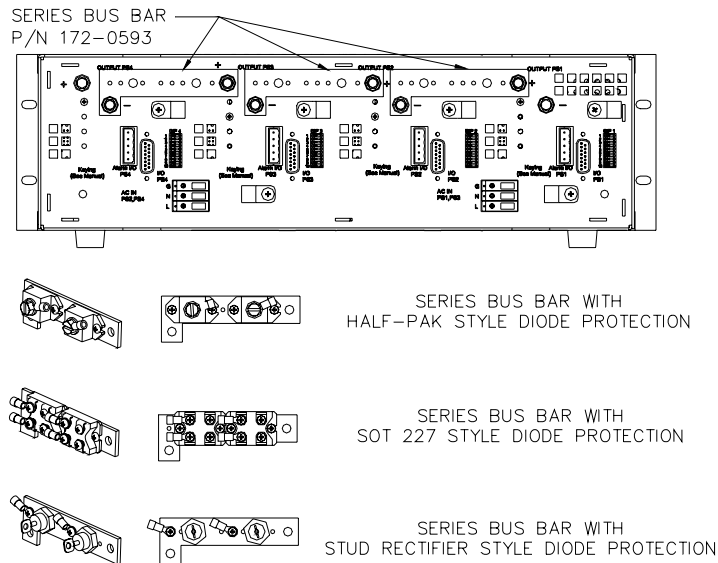

3043473

FIGURE 2-21. SERIES BUS BAR INSTALLATION

2.8.3 INSTALLING OPTIONAL LOCKING BRACKET

Locking Bracket, P/N 128-2339 is available as an accessory to provide increased support for severe vibration or shock environments on a fully populated rack and it is intended to be used as such. Use of this bracket will increase the time required to remove and replace a module, and there is a possibility the rack adapter may be scratched during the process; contact Kepco applications engineering to be sure this bracket is the right solution.

To mount the locking bracket, refer to Figure 2-22 and proceed as follows:

1. Insert HSF power supplies into rack adapter with HSF front panel locking screws in lock position, but not tight.
2. Verify rack adapter is secured to cabinet rail with the two upper mounting screws at (see Figure 2-22), then remove two lower mounting screws.
3. Position the locking bracket 3/4 inch from HSF front panels and hook it around HSF handles by moving it upward and to the right.
4. Push locking bracket toward front panel of HSFs, making sure that all HSF locking screws are protruding through corresponding holes in locking bracket. NOTE: If filler panels are installed, the lower screws must either be removed or replaced with 6-32 flat head screws to avoid interference between the locking bar and the pan head screws supplied with the filler panel.
5. Tighten the lower mounting screws, making sure that locking bracket is flush with HSF front panels.
6. Tighten HSF locking screws using 5/32" Allen wrench.

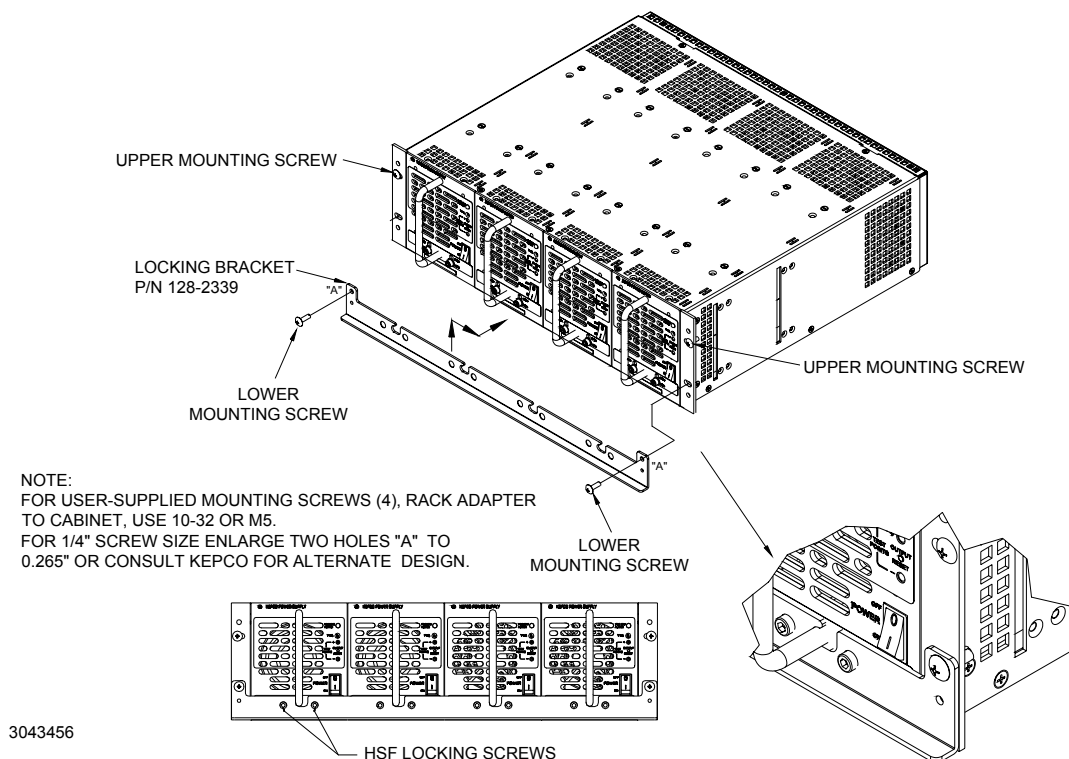

FIGURE 2-22. OPTIONAL LOCKING BRACKET INSTALLATION

2.9 INSTALLING HSF POWER SUPPLIES

HSF 300W, 600W, 1200W and 1500W power supplies are provided with two (2) retention latches located at each side of the bottom edge of the front panel (see Figure 1-2). These latches work in conjunction with the RA 19-4C rack adapter to prevent unauthorized or inadvertent module extraction from an operating power system.

Each latch is engaged by loosening the cap-head screw approximately 1/2 turn CCW (use 5/32" hex key) and sliding the latch down to the bottom of the slot, then retightening the cap-head screw CW until snug. **DO NOT OVERTIGHTEN!** To release, follow the same procedure, except lift the latch to the top of the slot. Be sure to move the latch completely up or down to ensure full engagement and disengagement of the latching mechanism. When the HSF power supply is not installed in its plug-in rack adapter, it is recommended that the latch be secured in the open (up) position to prevent damage.

NOTE: If optional locking bracket is in use, refer to PAR. 2.8.3 for power supply installation.

Refer to Figure 1-1, for proper slot positions applicable to the RA 19-4C Rack Adapter. With the retaining latches disengaged (at the top of the slot) as described above, insert HSF power supply in selected slot until power supply front panel is flush with rack adapter chassis, then secure the retaining latches as described above.

NOTE: Retaining latches must *not* be used to secure the HSF power supply in the rack adapter for shipping purposes.

The rack adapter is supplied with six cable clamps equipped with release levers that can be snapped into holes provided in the rear panel (see Figure 1-4) to support the weight of the input, output and signal cables.

NOTE: For severe shock and vibration environments each HSF module must be secured to the rack adapter with four screws screw, P/N 101-0486 (flat head, M4, 82° undercut) through the top of the rack adapter chassis and two screws screw, P/N 101-0491 (flat head, 6-32, 1/2 in. lg., 100° CSK) through the bottom of the rack adapter chassis. **Do not overtighten these screws: max. torque is 10 in.-lbs (1.1N x m)**; side support for the populated rack adapter may also be required. Additional support may be obtained by installing the optional locking bracket (see PAR. 2.8.3).

2.10 REMOVING HSF POWER SUPPLIES



Removal of an HSF power supply from a “live” system must be done only by authorized service personnel after HSF power switch is set to OFF. Dangerous voltages may be accessible through the open slot after a power supply is removed.

Set the POWER ON/OFF switch to off, then loosen the two retaining latches (see PAR. 2.9) and pull the HSF power supply out of the rack adapter. Refer to PAR. 2.9 for replacement.

2.11 WIRING INSTRUCTIONS

Interconnections between an a-c power source and a stabilized power supply, and between the power supply and its load are as critical as the interface between other types of electronic equip-

ment. If optimum performance is expected, certain rules for the interconnection of source, power supply and load must be observed by the user. These rules are described in detail in the following paragraphs and in the operating instructions for HSF Series power supplies.

2.11.1 SAFETY GROUNDING

Local, national and international safety rules dictate the grounding of the metal cover and case of any instrument connected to the a-c power source, when such grounding is an intrinsic part of the safety aspect of the instrument. The instructions below suggest wiring methods which comply with these safety requirements; however, in the event that the specific installation for the power system involves differences with the recommended wiring, it is the customer's responsibility to ensure that all applicable electric codes for safety grounding requirements are met.

2.11.2 SOURCE POWER CONNECTIONS

The RA 19-4C rack adapter is designed to be used in conjunction with Kepco HSF series power supplies. Source power requirements are determined by the HSF power supply (see HSF power supply Instruction Manual); no adjustment or modification of the rack adapter is required.

Source power is applied to two 3-terminal terminal blocks at the rear panel and distributed as indicated in Figure 1-3. Slots 1 and 3 are powered from one terminal block, slots 2 and 4 are powered from the other. When each terminal block receives power from a separate source, input redundancy for adjacent pairs of power supplies is achieved.

CAUTION

DO NOT EXCEED MAXIMUM TERMINAL BLOCK RATING OF 500V AT 36A.

Source power can also be custom configured via jumpers on the internal PC board, e.g., all slots can be powered from a single terminal block, or slots 1 and 2 can be powered from one terminal block and slots 3 and 4 from the other. Contact Kepco Applications Engineering for further details.

CAUTION

THE RA 19-4C DOES NOT INCORPORATE ANY SAFETY INTERRUPT DEVICES. PROTECTION OF INPUT WIRING REQUIRES USER-CONFIGURED SAFETY INTERRUPTS.

Wires must be sized according to expected current. Wire size range for each terminal block is AWG 20-10/IEC, rigid: 0.5 - 6mm², or flexible (stranded): 0.5 - 4mm²; torque to 6 lb-in (0.6 N•M) maximum. The terminals are labeled L, N, and G. Their functions are:

- **Terminal G (Ground)** is the safety ground connection for the RA 19-4C. It is connected to the RA 19-4C chassis and to the safety ground terminal of the input power connector for each of the power supply mounting positions via the PCB backplane. Terminal G must be connected to safety ground in order to ensure proper grounding of the HSF power supplies.
- **Terminals L (Line Phase) and N (Neutral)** are connected to the input power entry connectors. Source power is provided to the power supplies indicated by the label on the rear panel. The source power connectors are independent of each other, allowing the user complete flexibility in wiring for common or redundant input power configurations.

The following standard wiring configuration is recommended by Kepco as being compliant with applicable national and international safety standards. Please consult local electrical codes for wire current ratings and other specific requirements:

- Connect Terminal G of each RA 19-4C input power terminal block to safety ground
- Connect a separate wire pair from each side of the input power to the L/N terminal pair of the input power terminal block.
- In North America where 115/230V a-c source power is used, Kepco recommends the use of a Kepco line cord (P/N 118-1145, North American style plug, 30A maximum, 6 ft. long). European applications may require the use of Kepco line cord P/N 118-1146 (250V, 32A maximum).
- Wire size is determined by the maximum rated source current for each HSF power supply and the number of power supplies installed. For lower system power configurations, smaller wire can be used; contact Kepco Applications Engineering for assistance.

2.11.2.1 EMI COMPLIANCE

Depending on the application and system environment, special source power considerations may be required to meet listed Input EMI specifications for HSF power supplies, particularly FCC Class B. It may be necessary to add external source power filtering, such as installing snap-on ferrite beads on the line cord wires of the RA 19-4C as close to the input a-c terminal block as possible. Another option is to add an in-line cabinet-mounted EMI filter (available from a number of manufacturers) between the source power and the RA 19-4C line cord. For additional assistance, contact Kepco Applications Engineering.

2.11.3 CONTROL SIGNAL CONNECTIONS

Access to the control signal (I/O) connector for each HSF power supply is provided via four 15-pin D-subminiature connectors on the rear panel of the rack adapter (see Figure 1-4). Four mating connectors (Kepco P/N 142-0449) are provided in a plastic bag. Consult PAR. 2.4 and the HSF operator's manual for instructions on wiring and use of these control lines.

2.11.4 OUTPUT LOAD CONNECTIONS

Load connections to the rack adapters are achieved via four pairs (DC OUTPUT + and –) of output terminals located on the rear panel assembly. Wire gage may be between 22 GA and 6 GA depending on ring lug used; torque to 20 lb-in (2.3 N•M) maximum.

2.11.4.1 REDUCING RIPPLE AND NOISE

Ripple and noise are measured under nominal load conditions to provide the rated output voltage/current of the HSF power supply. Measurement of ripple/noise is illustrated in Figure 2-23. It is most important to minimize impedance between the power supply output and the load. As the length of load wires increases, ripple and noise may increase proportionally, therefore length and placement are critical for minimum ripple and noise. A filter consisting of a 50 μ F electrolytic capacitor in parallel with a 0.01 μ F capacitor must be used to eliminate unwanted ripple and noise pickup on the load wire during measurements. For noise-sensitive applications the load wires and sense wires must be twisted.

2.11.4.2 PARALLEL/REDUNDANT OPERATION

**WARNING**

Removal of an HSF power supply from a “live” system must be done only by authorized service personnel after HSF power switch is set to OFF. Dangerous voltages may be accessible through the open slot after a power supply is removed.

Identical HSF power supplies can be connected in parallel to provide redundant operation or increased output current to a common load. Maximum output current for each pair of the DC OUTPUT terminals is 70 Amperes. Connect the DC OUTPUT terminals of each paralleled power supply directly to the load. DO NOT DAISY CHAIN load wire conductors (See Figure 2-7).

Bus bars are available as accessories to make the connections when paralleling adjacent slots (refer to Table 1-2). When using the bus bars, the output is available from 1/4”-20 studs or pemnuts at the busbar links. When using the bus bars, maximum output current is 140 Amperes for two paralleled units, 210 Amperes for three paralleled units, and 280 Amperes for four paralleled units.

NOTE: Verify that the current share bus lines are configured per PAR. and 2.4.2.4.

2.11.4.3 SERIES/INDEPENDENT OPERATION

The rack adapter can be used for either independent or series operation of HSF power supplies; it is factory configured for independent operation. For series operation refer to PAR. 2.4.3.

2.11.4.4 MIXED OPERATION

The design of the RA 19-4C rack adapters permits the user to configure HSF power supplies for almost any combination of independent, series and parallel operation, both within a single rack adapter and between different RA 19-4C rack adapters, within the limits of the HSF operation envelope and the current and voltage ratings specified in PAR.s 2.11.4.2 and 2.11.4.3. The user must ensure that the requirements for each configuration stated above are met. If any questions or problems arise, the user is encouraged to contact the Kepco Applications Engineering group for technical assistance.

2.12 REMOVING/REPLACING HSF POWER SUPPLIES

**WARNING**

Removal of an HSF power supply from a “live” system must be done only by authorized service personnel after HSF power switch is set to OFF. Dangerous voltages may be accessible through the open slot after a power supply is removed.

Refer to PAR. 2.10 for instructions for removal and replacement of HSF power supplies.

2.13 SHIPPING

The rack adapter may be shipped with power supplies installed *only* after each HSF power supply has been securely fastened to the rack adapter using six screws, four at the top and two at

the bottom of the chassis (see NOTE to PAR. 2.9). Contact Kepco Applications Engineering if further assistance is required. Without power supplies the rack adapter weighs 16 lbs. (7.3Kg).

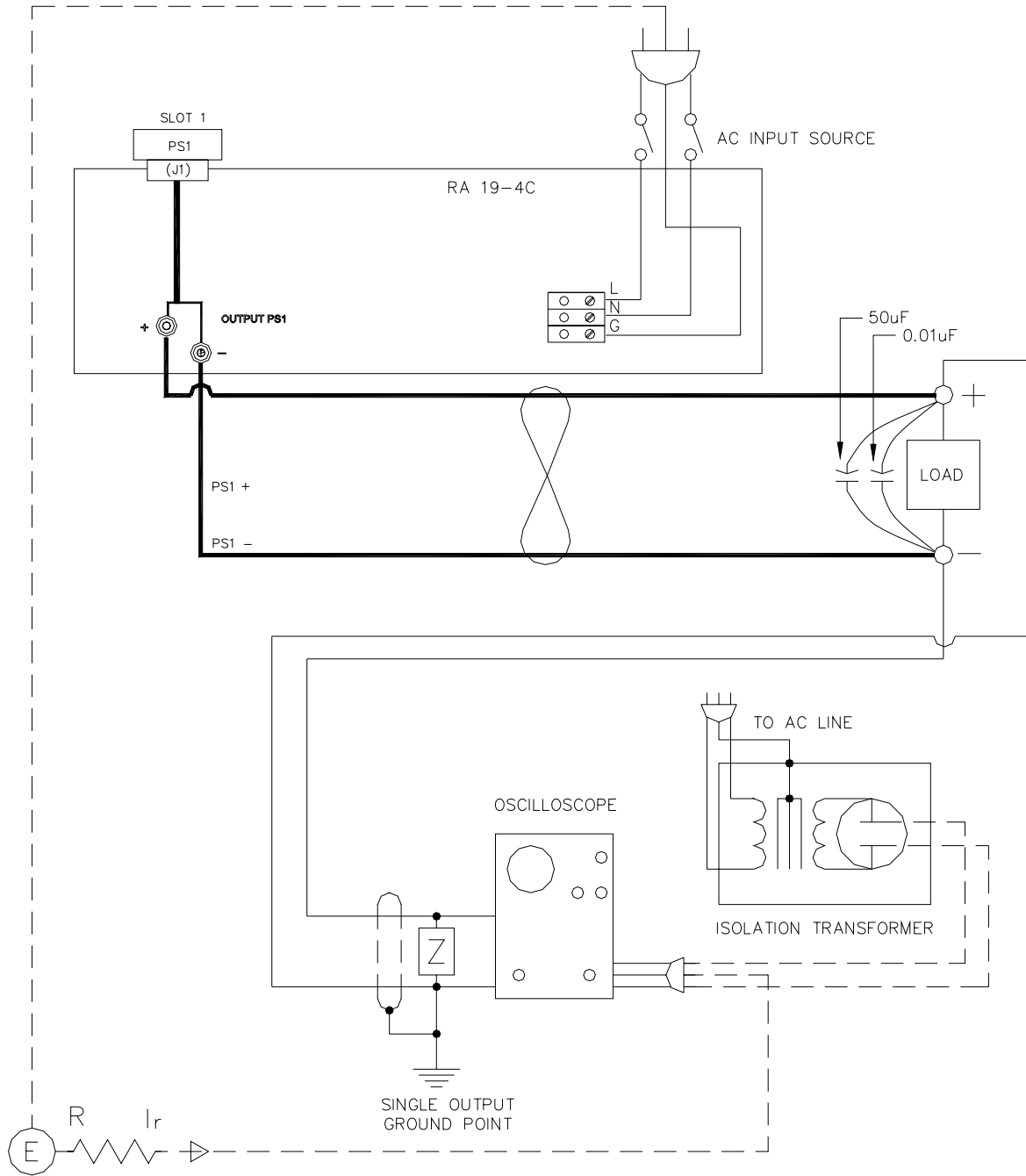

3042854

FIGURE 2-23. RIPPLE AND NOISE MEASUREMENT SETUP DIAGRAM

