

INSTRUCTION MANUAL

RA 19-3B RACK ADAPTER

HOT SWAP RACK ADAPTER FOR HSF SERIES POWER SUPPLIES

KEPCO INC.
An ISO 9001 Company.

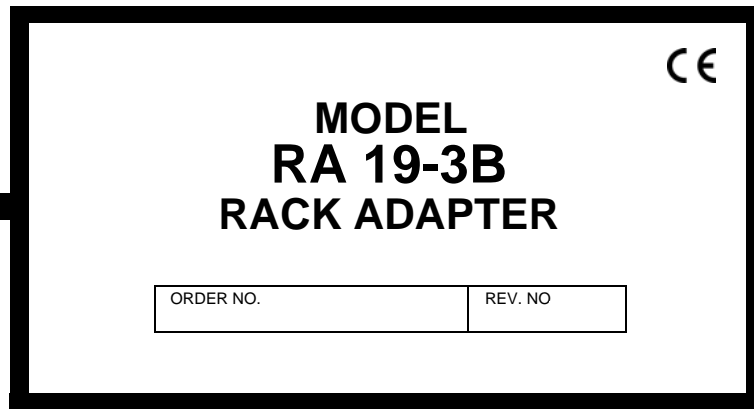

IMPORTANT NOTES:

- 1) This manual is valid for the following Model and associated serial numbers:

MODEL	SERIAL NO.	REV. NO.
- 2) A Change Page may be included at the end of the manual. All applicable changes and revision number changes are documented with reference to the equipment serial numbers. Before using this Instruction Manual, check your equipment serial number to identify your model. If in doubt, contact your nearest Kepco Representative, or the Kepco Documentation Office in New York, (718) 461-7000, requesting the correct revision for your particular model and serial number.
- 3) The contents of this manual are protected by copyright. Reproduction of any part can be made only with the specific written permission of Kepco, Inc.

Data subject to change without notice.

©2009, KEPCO, INC
P/N 243-0937R3



KEPCO, INC. ● 131-38 SANFORD AVENUE ● FLUSHING, NY. 11355 U.S.A. ● TEL (718) 461-7000 ● FAX (718) 767-1102
email: hq@kepcopower.com ● World Wide Web: <http://www.kepcopower.com>

Declaration of Conformity

Application of Council directives: **73/23/EEC (LVD)**
93/68/EEC (CE mark)

Standard to which Conformity is declared:

EN60950-1:1992 +A1: 1993 + A2 : 1993 (Safety of information technology equipment,
including electrical business equipment)

Manufacturer's Name and Address: **KEPCO INC.**
131-38 SANFORD AVENUE
FLUSHING, N.Y. 11355 USA

Importer's Name and Address:

REPRESENTATIVE COPY

Type of Equipment: **Rack Adapter**

Model No.: *[PRODUCT MODEL NUMBER]*

Year of Manufacture:

I, the undersigned, declare that the product specified above, when used in conjunction with the conditions of conformance set forth in the product instruction manual, complies with the requirements of the Low Voltage Directive 73/23/EEC, which forms the basis for application of the CE Mark to this product.

Place: **KEPCO Inc.**
131-38 Sanford Ave.
Flushing, N.Y.11355 USA

Saul Kupferberg
(Full Name)

Date: _____

VP OF SALES
(position)

Conditions of Conformance Rack Adapter products (EN60950)

When this product is used in applications governed by the requirements of the EEC, the following restrictions and conditions apply:

1. For European applications, requiring compliance to the Low Voltage Directive, 73/23/EEC, this Rack Adapter is considered a component, designed for "building in". Because it is incomplete in construction, the end product enclosure must provide for compliance to any remaining electrical safety requirements and act as a fire enclosure. (EN60950, CL.2.1, 2.7, 3.3, 4.3 and 4.4.5).
2. This Rack Adapter is designed for stationary installation, with mains power applied via a detachable power supply cord or via direct wiring to a source power terminal block.
3. This Rack Adapter, when properly installed, is considered a Class 1 (earthed) product, and as such depends upon proper connection to protective earth for safety from electric shock. (EN60950 Cl. 2.5)
4. This product is intended for use as part of equipment meant for an Information Technology Equipment environment. It is designed to operate from single phase, three wire TN power systems. This equipment must be installed within a suitably wired equipment rack, utilizing a three wire (grounded) mains connection. See wiring section of this manual for complete electrical wiring instructions.
5. When fitted with the appropriate power supplies, this product may have secondary output circuits that are considered hazardous, and which exceed 240 VA at a potential of 2V or more.
6. The output wiring terminals of this power supply have not been evaluated for field wiring and, therefore, must be properly configured by the end product manufacturer prior to use.
7. For complete circuit protection of the end product, as well as the building wiring, it is required that a primary circuit protection device be fitted to the branch circuit wiring. (EN60950 Cl. 2.5).
8. When installed with other components and/or power supplies, hazardous voltages may be present within the equipment during normal operation. All operator adjustments are made via externally accessible switches, controls and signal lines as specified within the individual power supply operating instructions. There are no user or operator serviceable parts within this product enclosure. Refer all servicing to qualified and trained Kepco service technicians.

SAFETY INSTRUCTIONS

1. Installation, Operation and Service Precautions

This product is designed for use in accordance with EN 60950 and UL 1950 for Installation Category 2, Pollution Degree 2. Hazardous voltages are present within this product during normal operation. The product should never be operated with the cover removed unless equivalent protection of the operator from accidental contact with hazardous internal voltages is provided



There are no operator serviceable parts or adjustments within the product enclosure. Refer all servicing to trained service technician.



Source power must be removed from the product prior to performing any servicing.



This product is factory-wired for the nominal a-c mains voltage indicated on the rating nameplate located adjacent to the source power connection on the product's rear panel.

2. Grounding

This product is a Class 1 device which utilizes protective earthing to ensure operator safety.



The PROTECTIVE EARTHING CONDUCTOR TERMINAL must be properly connected prior to application of source power to the product (see instructions on installation herein) in order to ensure safety from electric shock.



PROTECTIVE EARTHING CONDUCTOR TERMINAL - This symbol indicates the point on the product to which the protective earthing conductor must be attached.



EARTH (GROUND) TERMINAL - This symbol is used to indicate a point which is connected to the PROTECTIVE EARTHING TERMINAL. The component installer/ assembler must ensure that this point is connected to the PROTECTIVE EARTHING TERMINAL.

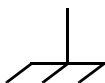

CHASSIS TERMINAL - This symbol indicates frame (chassis) connection, which is supplied as a point of convenience for performance purposes (see instructions on grounding herein). This is not to be confused with the protective earthing point, and may not be used in place of it.

3. Electric Shock Hazards

This product outputs hazardous voltage and energy levels as a function of normal operation. Operators must be trained in its use and exercise caution as well as common sense during use to prevent accidental shock.



This symbol appears adjacent to any external terminals at which hazardous voltage levels as high as 500V d-c may exist in the course of normal or single fault conditions.



This symbol appears adjacent to any external terminals at which hazardous voltage levels in excess of 500V d-c may exist in the course of normal or single fault conditions.

TABLE OF CONTENTS

SECTION	PAGE
SECTION 1 - INTRODUCTION	
1.1	Scope of Manual 1-1
1.2	General Description..... 1-1
1.3	Electrical..... 1-1
1.4	Mechanical 1-2
1.5	Accessories 1-2
1.6	Options 1-2
SECTION 2 - INSTALLATION	
2.1	Unpacking and Inspection 2-1
2.2	Configuring the Rack Adapter 2-1
2.3	Rack Adapter Keying Instructions 2-1
2.3.1	Disassembly to Gain Access to Interior Components..... 2-1
2.3.2	Establishing Key Positions..... 2-2
2.4	Slot Configuration..... 2-3
2.4.1	Independent Operation 2-4
2.4.1.1	Independent Operation - Local Sensing Using Internal DIP switches 2-5
2.4.1.2	Independent Operation - Local Sensing Using External Wiring 2-6
2.4.1.3	Independent Operation - Remote Sensing 2-7
2.4.2	Parallel Operation 2-8
2.4.2.1	Parallel DC OUTPUT Connections 2-8
2.4.2.2	Parallel Current Share Connections 2-8
2.4.2.2.1	Parallel Current Share - Internal DIP Switches 2-9
2.4.2.2.2	Parallel Current Share - External Wiring 2-10
2.4.2.3	Sense Connections for Parallel Configurations 2-11
2.4.2.3.1	Parallel Configuration Using DIP Switches to Connect Sense Lines in Parallel and External Wires to Configure Local Sensing 2-12
2.4.2.3.2	Parallel Configurations using External Wires to Connect Sense Lines in Parallel and External Wires to Configure Local Sensing 2-13
2.4.2.3.3	Parallel Configurations using DIP Switches to Connect Sense Lines in Parallel and External Wires to Configure Remote Sensing 2-14
2.4.2.3.4	Parallel Configurations using External Wires to Connect Sense Lines in Parallel and External Wires to Configure Remote Sensing 2-15
2.4.3	Series Operation..... 2-16
2.4.4	Alarm Configurations 2-17
2.4.4.1	N.O. Alarm Line (Close on Failure)..... 2-17
2.4.4.1.1	Close on Failure Using Internal Dip Switches 2-17
2.4.4.1.2	Close on Failure Using External Wiring at I/O Mating Connector 2-19
2.4.4.2	N.C. Alarm Line (Open on Failure) 2-20
2.4.4.2.1	Open on Failure Using Internal Dip Switches 2-20
2.4.4.2.2	Open on Failure Using External Wiring of I/O Mating Connector..... 2-21
2.5	Terminations..... 2-21
2.6	Cooling 2-22
2.7	Installation 2-22
2.8	Wiring Instructions..... 2-22
2.8.1	Safety Grounding..... 2-22
2.8.2	Source Power Connections 2-22
2.8.3	Control Signal Connections 2-23
2.8.4	Output Load Connections 2-23
2.8.4.1	Parallel/Redundant Operation..... 2-24
2.8.4.2	Series/Independent Operation 2-24
2.8.4.3	Mixed Operation..... 2-24
2.9	Installing/Removing HSF Power Supplies 2-24
2.10	Shipping 2-24

LIST OF FIGURES

FIGURE	TITLE	PAGE
1-1	RA 19-3B Rack Adapter	iv
1-2	RA 19-3B Rack Adapter with HSF Power Supplies Installed	1-1
1-3	RA 19-3B Interconnections, Simplified Diagram	1-2
1-4	RA 19-3B Rack Adapter Rear Panel	1-3
1-5	Mechanical Outline Drawing, RA 19-3B Rack Adapter	1-4
2-1	Backplate Assembly, Interior View	2-2
2-2	Independent Operation, Local Sensing for PS1 and PS2 using Internal DIP switches, Simplified Diagram	2-5
2-3	Independent Operation, Local Sensing for PS1 and PS2 using External Jumpers at I/O Mating Connector, Simplified Diagram	2-6
2-4	Independent Operation, Remote Sensing for PS1 and PS2 using External Wiring at I/O Mating Connector, Simplified Diagram	2-7
2-5	Parallel Outputs Using Internal DIP Switches to Parallel sense lines and current share, PS1, PS2 and PS3 (Typical), Simplified Diagram	2-9
2-6	Parallel Outputs Using External Wiring, Typical Configuration, Simplified Diagram	2-10
2-7	Typical Parallel Connections, Local Sensing (External), External Wires and DIP switches	2-12
2-8	Typical Parallel Connections, Local Sensing (External), External Wires and I/O Mating Connector Jumpers	2-13
2-9	Typical Parallel Connections, Remote Sensing using DIP Switches to Parallel Sense Wires	2-14
2-10	Typical Parallel Connections, Remote Sensing using I/O Mating Connector Jumpers to Parallel Sense Wires	2-15
2-11	Series Configuration, Simplified Diagram	2-16
2-12	Close on Failure Alarm Configuration Using Internal Dip Switches, Simplified Diagram	2-18
2-13	Close on Failure Alarm Configuration Using External Wiring at I/O Mating Connector, Simplified Diagram	2-19
2-14	Open on Failure Alarm Configuration Using Internal Dip Switches, Simplified Diagram	2-20
2-15	Open on Failure Alarm Configuration Using External Wiring at I/O Mating Connector, Simplified Diagram	2-21

LIST OF TABLES

TABLE	TITLE	PAGE
1-1	Compatible HSF Power Supplies	1-3
1-2	RA 19-3B Accessories	1-3
2-1	Equipment Supplied	2-1
2-2	Configuration DIP Switch* Functions	2-3

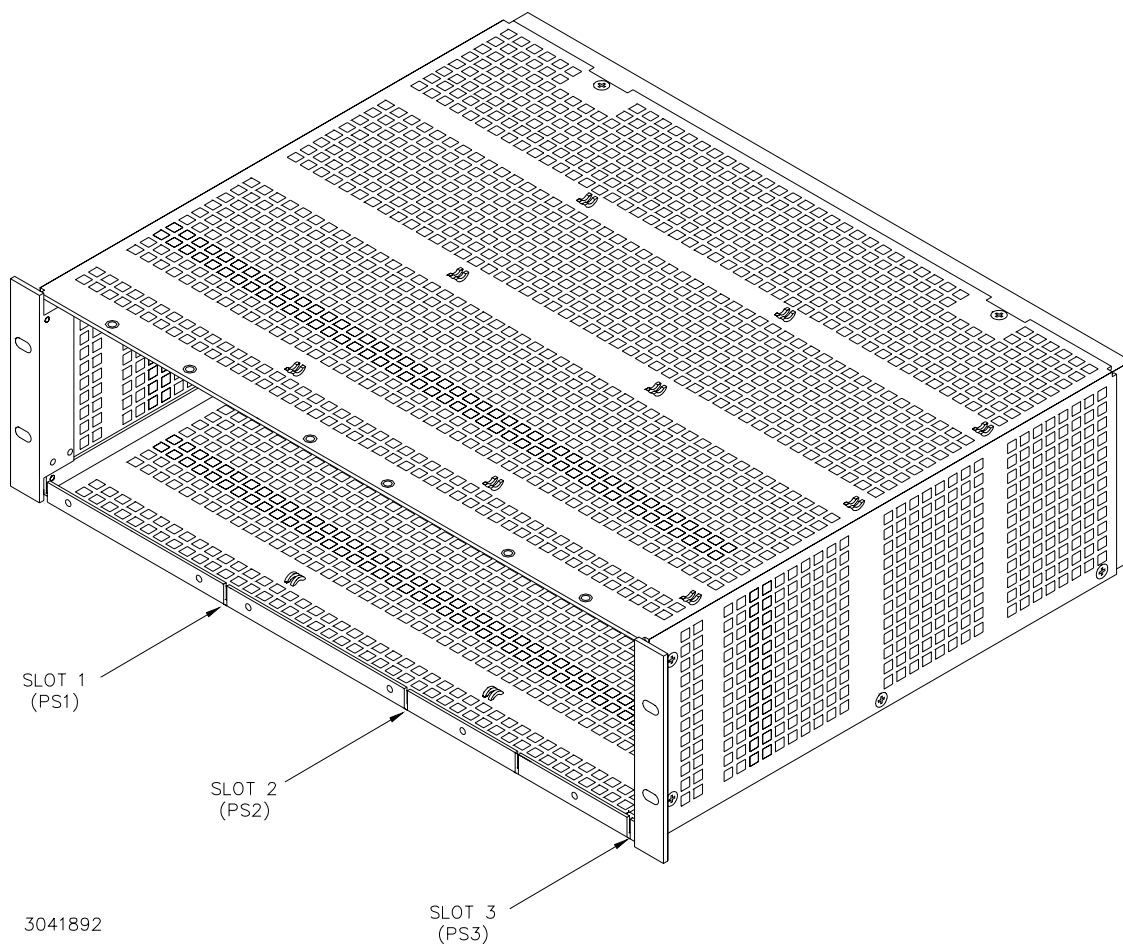

FIGURE 1-1. RA 19-3B RACK ADAPTER

SECTION 1 - INTRODUCTION

1.1 SCOPE OF MANUAL

This manual contains instructions for the installation and operation of the RA 19-3B plug-in rack adapter (Figure 1-1) used with HSF Series power supplies, manufactured by Kepco, Inc., Flushing, New York, U.S.A.

1.2 GENERAL DESCRIPTION

Kepco Series RA 19-(X)B rack adapters are specifically designed for the installation of Kepco HSF Series Power Supplies into 19-inch EIA standard equipment racks. The RA 19-3B Model accommodates up to three 350 Watt (1/3 rack) HSF power supplies (Figure 1-2).

NOTE: Model RA 19-4B can accommodate up to two 350 Watt modules and up to two 50 Watt (1/8 rack), 100 Watt (1/8 rack) or 150 Watt (1/6 rack) modules; contact Kepco Applications Engineering for assistance with non-standard configurations.

The rack adapter is user-configurable for parallel, series, or independent power supply operation. Forced current sharing and OR'ing diodes for N+1 redundancy are built into the HSF power supplies. User-configurable keying ensures that only the correct power supply can be installed in a keyed slot.

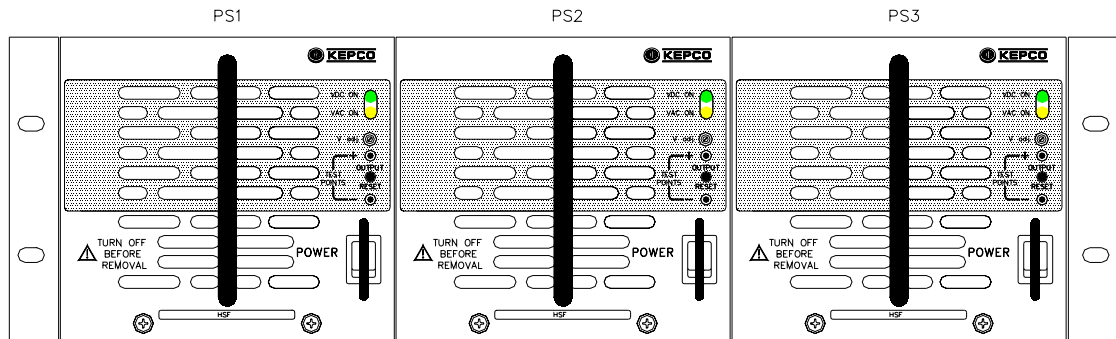

3041868

FIGURE 1-2. RA 19-3B RACK ADAPTER WITH HSF POWER SUPPLIES INSTALLED

1.3 ELECTRICAL

An internal PCB back plate mounts connectors which interface directly with the power and signal connectors of HSF Series power supplies, permitting hot swappable insertion and extraction. The other side of the back plate assembly, available from the rear, contains the fixed power and signal connections. Figure 1-3 illustrates the interconnections provided by the RA 19-3B Rack Adapter. Dual input terminal blocks on the back plate assembly (Figure 1-4) distribute input power to each of the three power supplies.

All mechanical and electrical specifications are contained in the mechanical outline drawing: Figure 1-5

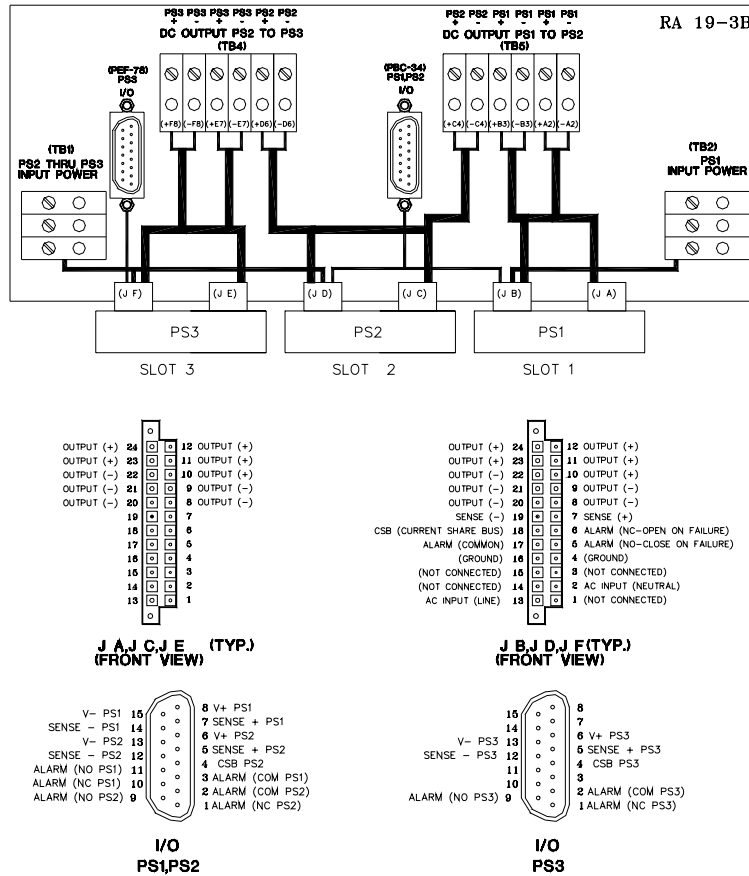

FIGURE 1-3. RA 19-3B INTERCONNECTIONS, SIMPLIFIED DIAGRAM

1.4 MECHANICAL

The rack adapter is equipped with mounting ears for mounting in EIA standard 19-inch racks. For mounting in non-standard racks, consult Kepco Applications Engineering. The rack adapter is not configured for slides. Optional blank filler panels (see Table 1-2) are available if the full complement of power supplies is not utilized.

Mechanical dimensions, material, and finish of the RA 19-3B Rack Adapter is provided in Figure 1-5.

1.5 ACCESSORIES

Accessories for RA 19-3B Rack Adapters are listed in Table 1-2.

1.6 OPTIONS

Table 1-1 below describes the standard model options available with Series RA 19-(X)B rack adapters. For non-standard options, contact Kepco Applications Engineering for assistance.

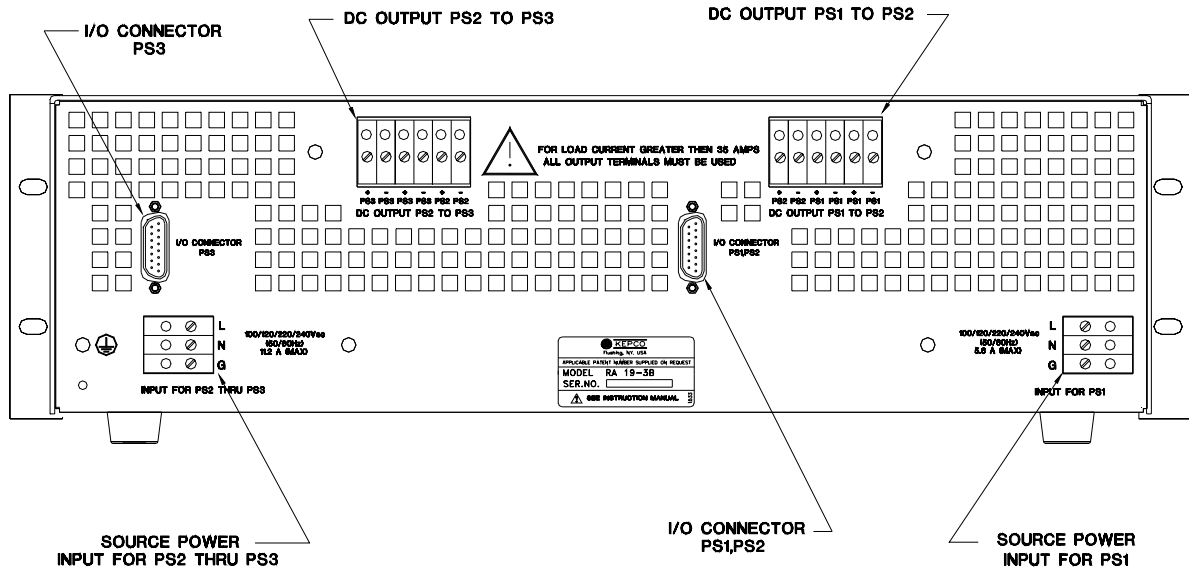

3041876

FIGURE 1-4. RA 19-3B RACK ADAPTER REAR PANEL

TABLE 1-1. COMPATIBLE HSF POWER SUPPLIES

MODEL	1/8 Rack Slots		1/6 Rack Slots		1/3 Rack Slots		
	Total	Compatible HSF Models		Total	Compatible HSF Models	Total	Compatible HSF Models
		50 Watt	100 Watt				
RA 19-3B	*			*		3 (max)	HSF3.3-70, HSF5-70, HSF12-30, HSF15-24, HSF24-16, HSF28-13, HSF48-7.5
RA 19-4B	2 (max)	HSF5-10, HSF12-4.2, HSF15-3.4, HSF24-2.1, HSF48-1	HSF5-20, HSF12-8.3, HSF15-6.6, HSF24-4.2, HSF28-3.5, HSF48-2	2 (max)	HSF5-30, HSF12-12, HSF15-10, HSF24-6, HSF28-5, HSF48-2.8	2 (max)	HSF3.3-70, HSF5-70, HSF12-30, HSF15-24, HSF24-16, HSF28-13, HSF48-7.5
RA 19-6B	*			6 (max)	HSF5-30, HSF12-12, HSF15-10, HSF24-6, HSF28-5, HSF48-2.8		
RA 19-7B	7 (max)	HSF5-10, HSF12-4.2, HSF15-3.4, HSF24-2.1, HSF48-1	HSF5-20, HSF12-8.3, HSF15-6.6, HSF24-4.2, HSF28-3.5, HSF48-2	4 (max)	HSF5-30, HSF12-12, HSF15-10, HSF24-6, HSF28-5, HSF48-2.8		
RA 19-8B	8 (max)	HSF5-10, HSF12-4.2, HSF15-3.4, HSF24-2.1, HSF48-1	HSF5-20, HSF12-8.3, HSF15-6.6, HSF24-4.2, HSF28-3.5, HSF48-2	*			

* Contact Kepco Applications Engineering for assistance with non-standard configurations.

TABLE 1-2. RA 19-3B ACCESSORIES

ACCESSORY	PART NUMBER	USE
Filler Panel (1/3 Rack)	RFP 19-13	Cover one unused 1/3 rack slot.
Filler Panel (2/3 Rack)	RFP 19-23	Cover two unused 1/3 rack slots.

Dimensions are in inches, [dimensions in brackets are in millimeters].

Tolerance: $\pm 1/64"$ (0.4) between mounting holes; $\pm 1/32"$ (0.8) other dimensions

NOTES:

1. MATERIAL:
 - A) CHASSIS, COVER STEEL CRS #14 GAGE
 - B) BACK COVER ALUMINUM #14 GA.
2. FINISH:
 - A) CHASSIS & COVER: YELLOW CHROMATE.
 - B) FRONT PANEL & ANGLE BKT: KEPCO GRAY.
 - C) BACK COVER: IRIDITE GOLD
3. RACK OR CABINET MOUNTING: REMOVE (4) PLASTIC FEET
4. DIMENSIONS IN PARENTHESES ARE IN MILLIMETERS.

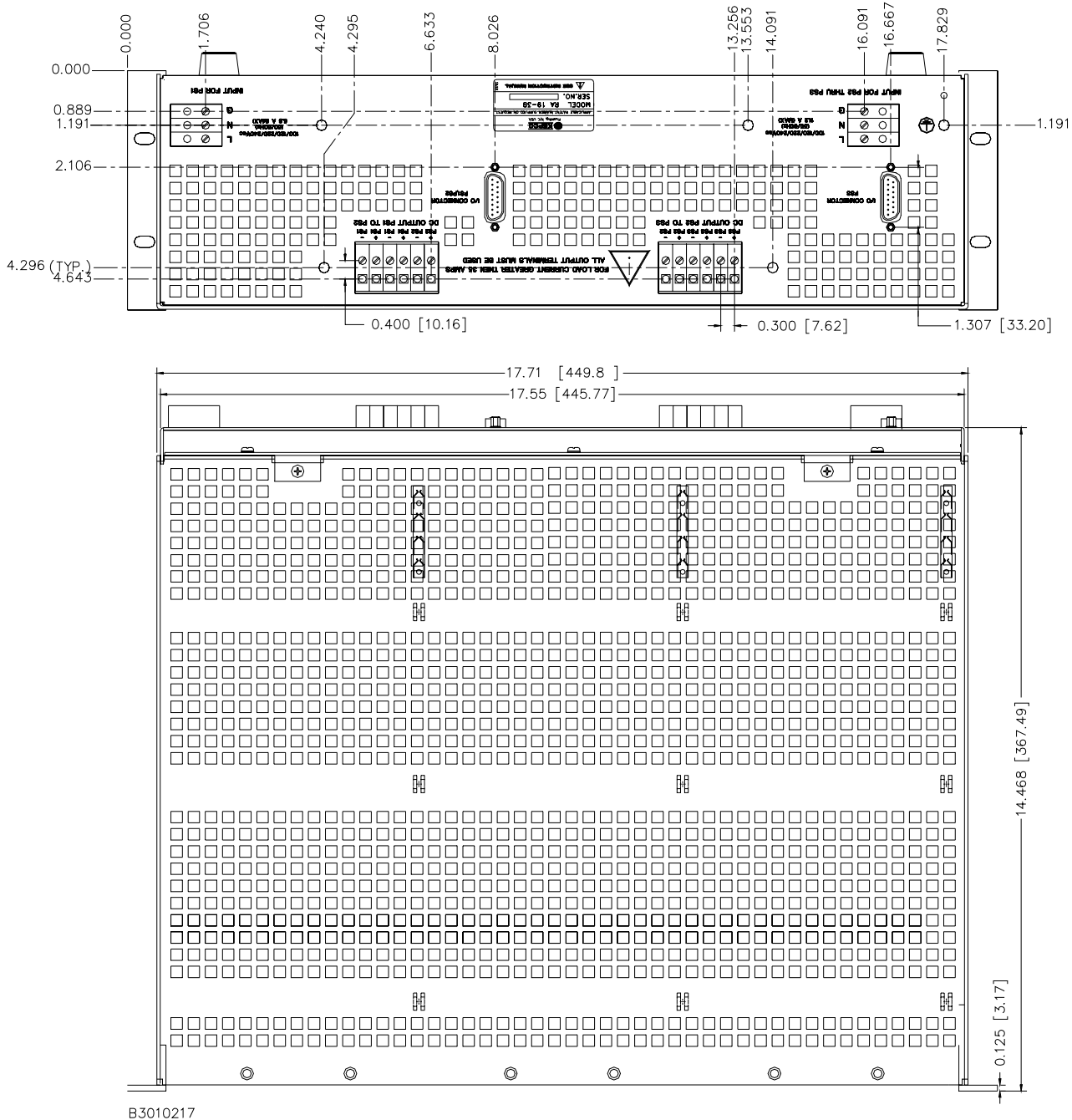

FIGURE 1-5. MECHANICAL OUTLINE DRAWING, RA 19-3B RACK ADAPTER (SHEET 1 OF 2)

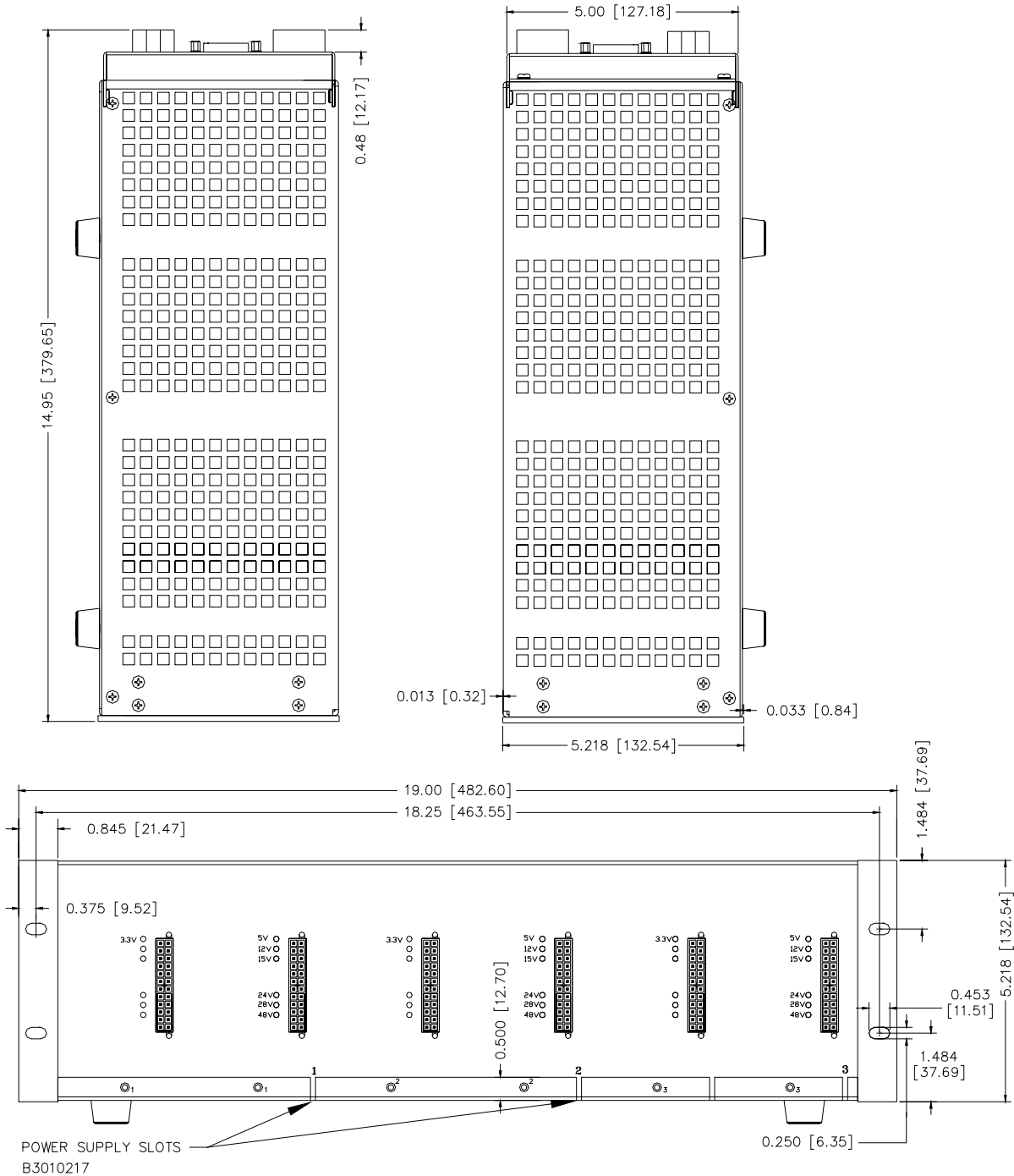

FIGURE 1-5. MECHANICAL OUTLINE DRAWING, RA 19-3B RACK ADAPTER (SHEET 2 OF 2)

SECTION 2 - INSTALLATION

2.1 UNPACKING AND INSPECTION

This equipment has been thoroughly inspected and tested prior to packing and is ready for operation. After careful unpacking, inspect for shipping damage before attempting to operate. If any indication of damage is found, file an immediate claim with the responsible transport service. See Table 2-1 for a list of equipment supplied.

TABLE 2-1. EQUIPMENT SUPPLIED

ITEM	QUANTITY	PART NUMBER
Rack Adapter	1	RA 19-3B
I/O Connector (Mating)	2	142-0449
Line cord (115 V a-c, 15A max, North American style plug, 6 ft.)	2	118-0506
Instruction Manual	1	243-0937
Keying pins	3	108-0305
Hood for I/O Connector (Mating) P/N 142-0449	2	108-0204

2.2 CONFIGURING THE RACK ADAPTER

Prior to installation the rack adapter must be configured by the user. Configuration consists of the following:

- For configurations that use multiple output voltages it is possible to key the rack adapter to accept only a power supply with corresponding keying (see PAR 2.3).
- Configuring slots for independent, parallel, or series operation. This can be done by means of internal DIP switches, or externally by wiring the associated I/O mating connector and DC OUTPUT terminals (see PAR. 2.4).

2.3 RACK ADAPTER KEYING INSTRUCTIONS

Series RA 19-(X)B rack adapters incorporate a keying mechanism to prevent accidental insertion of the incorrect model HSF power supply into any position. The HSF power supplies are keyed by voltage at the factory. The keying mechanism will prevent engagement of any of the HSF power supply's connectors with those on the rack adapter's back plate unless the key and keyway align. The user can configure each power supply position of the rack adapter for the desired voltage in the desired position (see Figure 2-1). First gain access to the interior components (PAR.2.3.1), then position the key as required (PAR. 2.3.2).

NOTE: After removing the rear panel, the keying pins can be accessed through the front of the rack adapter, although it is recommended that the back plate be removed to gain easy access to interior components.

2.3.1 DISASSEMBLY TO GAIN ACCESS TO INTERIOR COMPONENTS

NOTE: All power supplies must be removed prior to disassembly.

1. Remove four spacers securing the two I/O connectors to the rear panel

2. Remove the four screws (two at the top and two at the bottom) securing the rear panel to the chassis and separate the rear panel from the chassis (it is not necessary to remove the ground connection (if present) between the rear panel and the chassis).
3. Remove seven screws (three at the top and four at the bottom) securing the back plate to the chassis and remove the back plate to gain access to the interior components (see Figure 2-1)

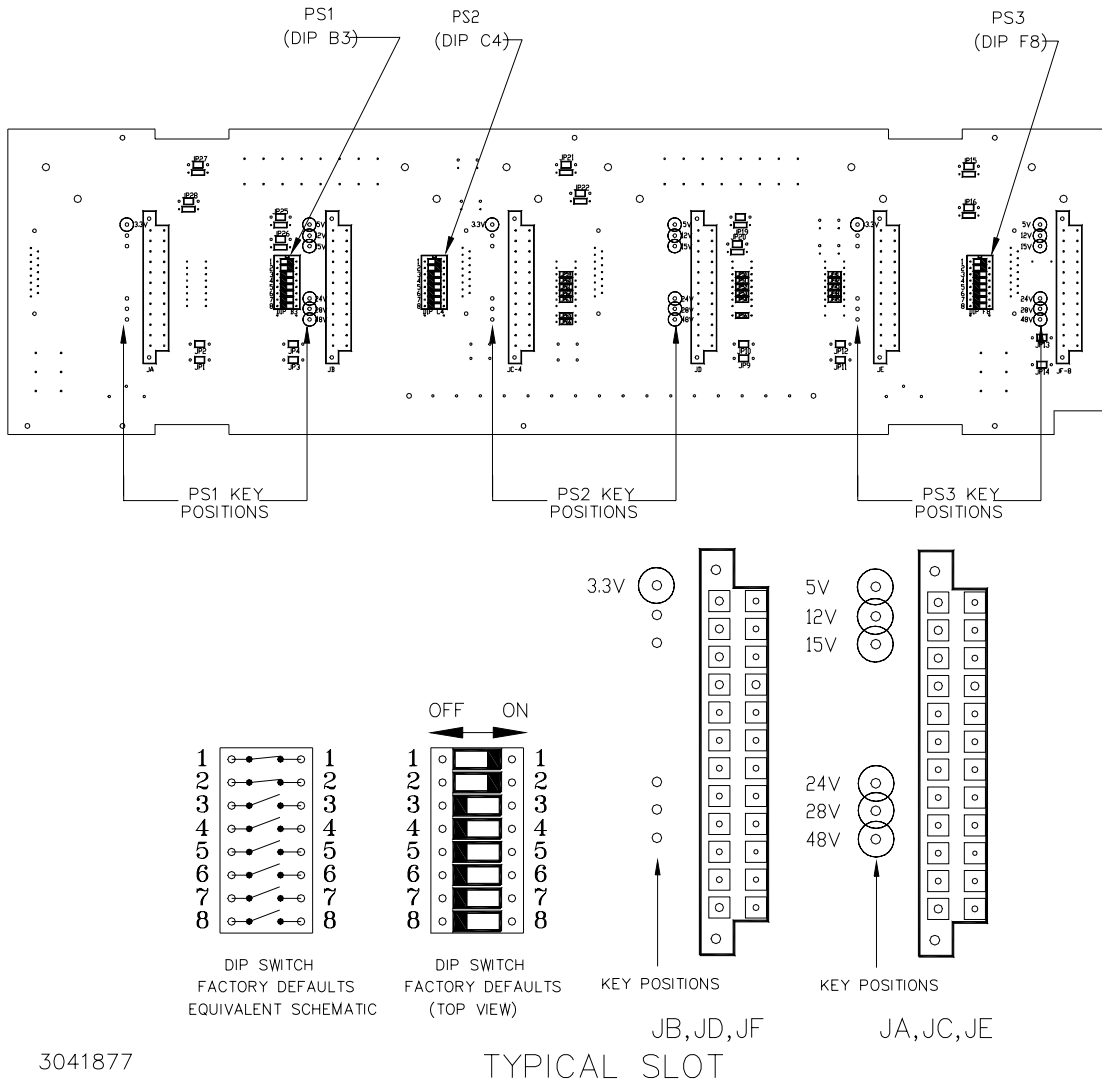

3041877

FIGURE 2-1. BACKPLATE ASSEMBLY, INTERIOR VIEW

2.3.2 ESTABLISHING KEY POSITIONS

To establish the keying of any position, simply insert the key pin from the front and secure with mounting nut at the back plate using two ¼" nutdrivers or deep sockets. RA 19-3B backplate assembly keying is identical to the HSF module keying identified in Figure 2-1 and in the HSF operator's manual. **DO NOT ALTER THE KEYING AT THE POWER SUPPLY.**

2.4 SLOT CONFIGURATION

Configuring slots of the rack adapter for independent, parallel or series operation is accomplished either internally by means of DIP switches associated with each slot (see Figure 2-1), or externally by connecting the appropriate pins of the associated I/O mating connector. DIP switch functions are explained in Table 2-2. Refer to PAR. 2.3.1 to gain access to the DIP switches.

Slot configuration requires the following selection:

1. Select independent (PAR. 2.4.1), parallel (PAR. 2.4.2), or series (PAR. 2.4.3) operation.
2. Select local or remote sensing; PAR. 2.4.1 (independent), 2.4.2, (parallel) or 2.4.3, (series).
3. Optional: Select close-on-failure or open-on-failure alarm (PAR. 2.4.4).

TABLE 2-2. CONFIGURATION DIP SWITCH* FUNCTIONS

DIP SWITCH POSITION	FUNCTION	DIP SWITCH SET TO ON (CLOSED)	DIP SWITCH SET TO OFF (OPEN)
NOTES: 1. BOLD TYPE INDICATES FACTORY SETTINGS. 2. For DIP switch A1, only positions 1 and 2 are active; all other positions are not connected.			
1, 2	Local / Remote Sensing Selection	Required ON for independent operation with Local Sensing. Position 1 connects V+ to S+, Position 2 connects V- to S- (see PAR. 2.4.1.1).	Position 1 and 2 required OFF for: a) Independent configurations using Remote Sensing (see PAR. 2.4.1.3). b) Independent configurations using Local Sensing with user supplied connections from V+ to S+ and V- to S- (see PAR. 2.4.1.2). c) All parallel configurations (sensing must be established using external wires) (see PAR. 2.4.2.3). d) All series connections (see PAR. 2.4.3).
3, 4	Connect Sense + and - in parallel	Required ON for parallel configurations using DIP switch settings to connect the sense leads in parallel. Position 3 connects +S to adjacent slot +S, Position 4 connects -S to adjacent slot -S (see PAR. 2.4.2.3.1 for local sensing, PAR. 2.4.2.3.3 for remote sensing).	Position 3 and 4 required OFF for all configurations except parallel configurations using DIP switch settings to connect the sense leads in parallel.
5	Current Share	Required ON for parallel operation using forced current sharing (connects current share lines in parallel) unless connections are made via external wires (see PAR. 2.4.2.2.1)	Required OFF for a) independent and series configurations. b) Parallel configurations with forced current sharing using external wires to connect current share lines in parallel. c. Parallel configurations without forced current sharing (current balancing).
6, 7	Close on Failure Alarm	When set to ON, allows a single alarm to provide failure indication (contact closure between N.O. pin and COM pin) if any one of many power supplies fails (see PAR. 2.4.4.1).	When set to OFF, individual power supplies produce closure between I/O connector N.O. and COM pins upon failure (see PAR. 2.4.4.1).
8	Open on Failure Alarm	When set to ON, allows a single alarm to provide failure indication (contact open between N.C. pin and COM pin) if any one of many power supplies fails (see PAR. 2.4.4.2).	When set to OFF, individual power supplies produce open between I/O connector N.C. and COM pins upon failure (see PAR. 2.4.4.2).

2.4.1 INDEPENDENT OPERATION

The rack adapter is preconfigured at the factory for independent operation of all slots. DIP switch positions 3, 4 and 5 associated with each slot must be set to OFF (open) for each power supply to be operated independently.

NOTE: Either local or remote sensing *must* be connected for the HSF power supplies to work properly.

The rack adapter is shipped from the factory with each power supply position configured for local sensing (see Figure 2-2). Sensing for each slot can be configured independently:

- Local sensing using internal DIP switches
- Local sensing using external jumpers connected to the I/O mating connector or the DC OUTPUT terminal block.
- Remote sensing

2.4.1.1 INDEPENDENT OPERATION - LOCAL SENSING USING INTERNAL DIP SWITCHES

The rack adapter slots are preconfigured at the factory for local sensing using internal DIP switches. If a slot has been configured for other than local sensing using DIP switches and it is necessary to reconfigure a slot for local sensing, simply set positions 1 and 2 of the DIP switch associated with that slot to ON (closed). External sensing connections must be removed. When set to ON (closed) DIP switch position 1 connects (V+) to (S+) and position 2 connects (V-) to (S-). See Figure 2-1 for DIP switch locations. Figure 2-2 illustrates local sensing of PS1 and PS2 by setting positions 1 and 2 of internal DIP switches B3 and C4 to ON (closed); positions 3 and 4 must be set to OFF (open). Position 5 (current share) must be set to OFF and positions 6, 7, and 8 (alarms) can be configured per PAR. 2.4.4.

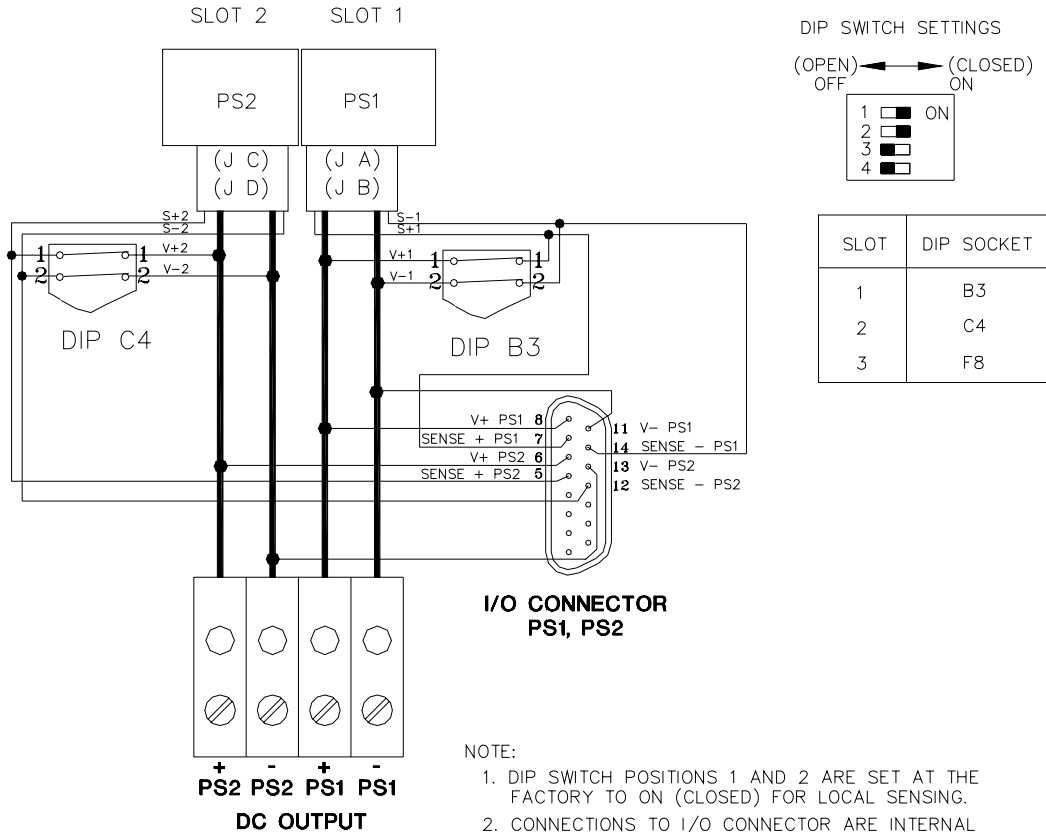

3041878

FIGURE 2-2. INDEPENDENT OPERATION, LOCAL SENSING FOR PS1 AND PS2 USING INTERNAL DIP SWITCHES, SIMPLIFIED DIAGRAM

2.4.1.2 INDEPENDENT OPERATION - LOCAL SENSING USING EXTERNAL WIRING

To configure a slot for local sensing using external wiring, first set internal DIP switch positions 1 and 2 of the DIP switches associated with that slot to OFF (open).

External local sensing is accomplished by connecting (V+) to (S+) and (V-) to (S-). This can be done at either the mating I/O connector supplied (see Table 2-1) or the DC OUTPUT terminal block. See Figure 2-1 for DIP socket locations. Figure 1-3 illustrates I/O connector pin assignments. Figure 2-3 illustrates local sensing of PS1 and PS2 using external jumpers connected to the I/O mating connector.

NOTE: The internal DIP switch settings established at the factory for positions 1 and 2 of the associated DIP switch MUST be changed to OFF (open) if this option is chosen.

Positions 3 and 4 (connecting sense lines in parallel) and Position 5 (current share) must be set to OFF. Configure Positions 6, 7, and 8 (alarms) per PAR. 2.4.4.

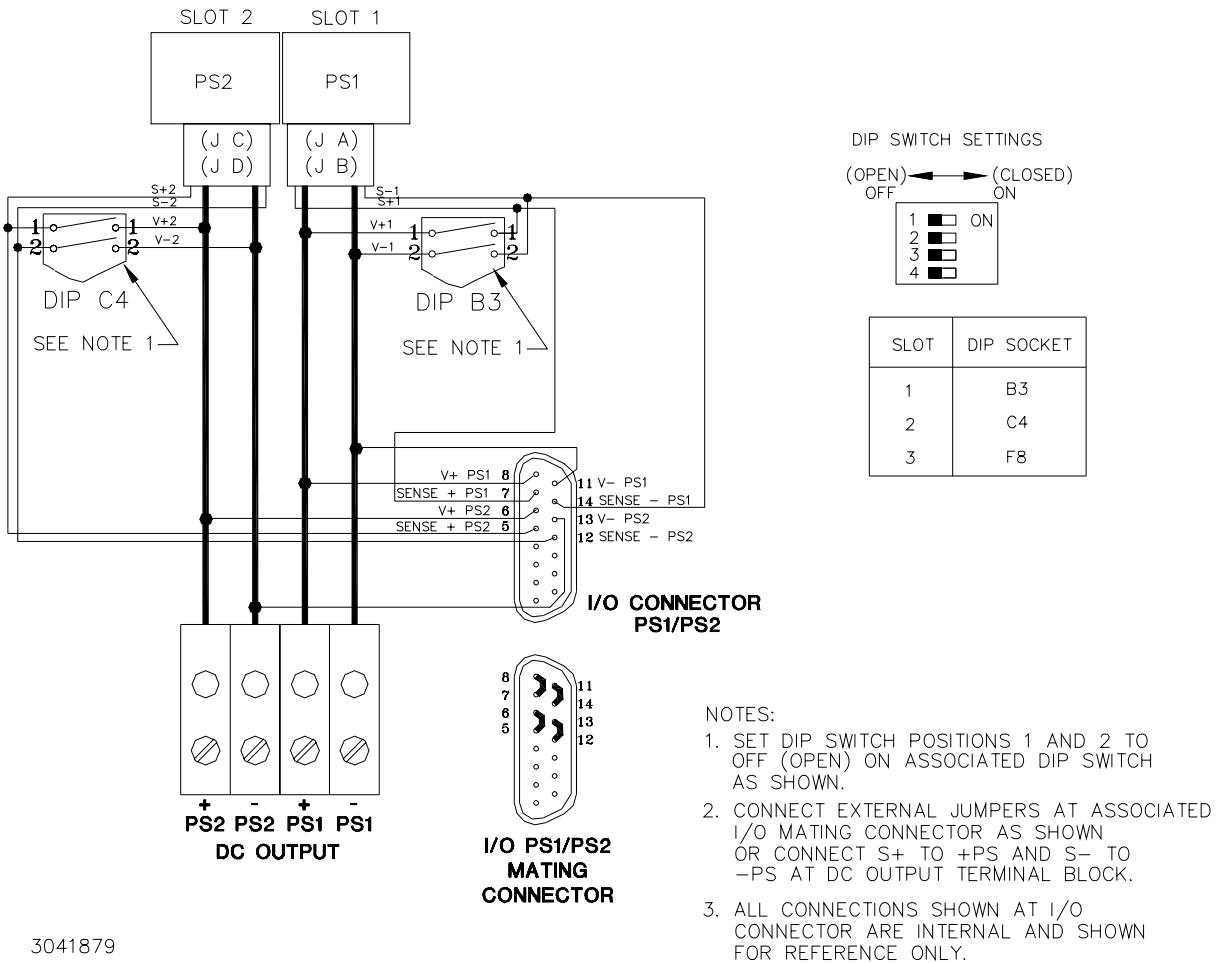

3041879

FIGURE 2-3. INDEPENDENT OPERATION, LOCAL SENSING FOR PS1 AND PS2 USING EXTERNAL JUMPERS AT I/O MATING CONNECTOR, SIMPLIFIED DIAGRAM

2.4.1.3 INDEPENDENT OPERATION - REMOTE SENSING

Remote sensing is accomplished by connecting +Load to (S+) and -Load to (S-). Figure 2-4 illustrates remote sensing for PS1 and PS2 using wires connected to the I/O mating connector.

NOTE: The internal DIP switch settings established at the factory for positions 1 and 2 of the associated DIP switch MUST be changed to OFF (open) if this option is chosen.

Positions 3 and 4 (connecting sense lines in parallel) and Position 5 (current share) must be set to OFF. Configure Positions 6, 7, and 8 (alarms) per PAR. 2.4.4.

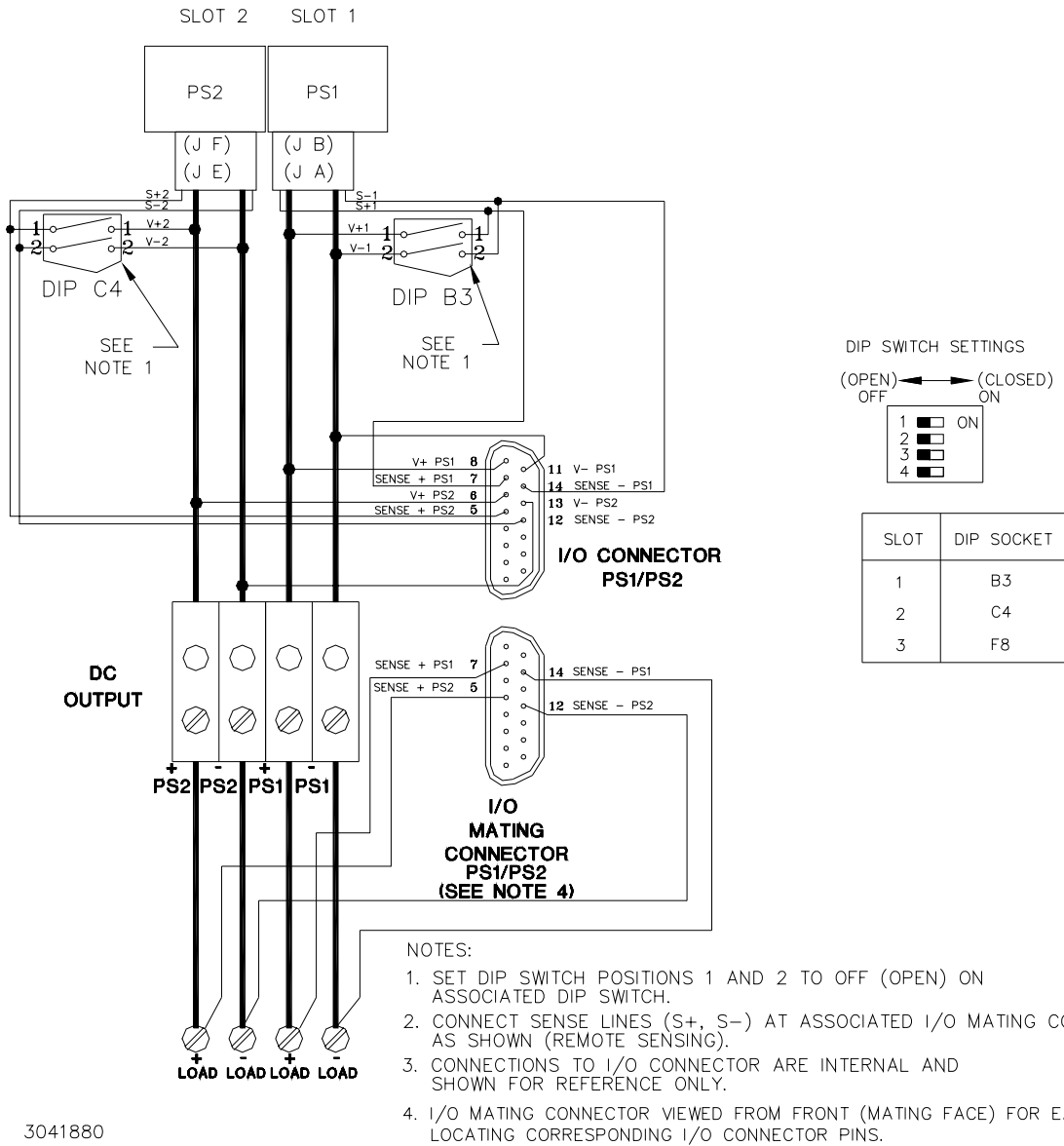

FIGURE 2-4. INDEPENDENT OPERATION, REMOTE SENSING FOR PS1 AND PS2 USING EXTERNAL WIRING AT I/O MATING CONNECTOR, SIMPLIFIED DIAGRAM

2.4.2 PARALLEL OPERATION

HSF power supplies having identical voltage ratings can be connected in parallel to provide redundant operation or increased output current to a common load. The power leads must be connected in parallel externally (see PAR. 2.8.4.1). (Configurations using internal parallel busing are also possible; consult Kepco's Applications Engineering for details.) Three things must be considered when configuring the rack adapter for parallel operation:

- DC OUTPUT
- CURRENT SHARE
- SENSE

2.4.2.1 PARALLEL DC OUTPUT CONNECTIONS

The power leads must be connected in parallel externally (see PAR. 2.8.4.1). DC Output V(+) and V(-) must be connected in parallel at the DC OUTPUT terminal block (see Figures 2-5 through 2-10).

2.4.2.2 PARALLEL CURRENT SHARE CONNECTIONS

The Current Share pins of the HSF power supplies must be connected together for parallel operation. This can be done either internally using the DIP switches to configure adjacent slots in parallel (PAR 2.4.2.2.1), or externally by wiring the I/O mating connector for configuring slots 2 and 3 (PAR. 2.4.2.2.2).

2.4.2.2.1 PARALLEL CURRENT SHARE - INTERNAL DIP SWITCHES

To configure adjacent slots, use the internal DIP switches to connect the Current Share bus. Using internal DIP switches permits only adjacent power supplies be connected in parallel (i.e., PS1/PS2, PS2/PS3 and PS1/PS2/PS3). PS1 and PS3 cannot be configured in parallel using internal DIP switches without including PS2 as well. Contact Kepco Applications Engineering for non-standard configurations using internal DIP switches.

To connect the current share lines locate DIP switches C4 and F8 (see Figure 2-1) and set position 3, 4, 5 to ON (closed). For example to connect PS1, PS2 and PS3 in parallel, set DIP switches F8 and C4, position 3, 4, 5, to ON (closed) (see Figure 2-5); set DIP switch B3, positions 1 through 5 to OFF (open) (positions 1-2 of B3 must be OFF for parallel configurations and positions 3-5 are not connected).

NOTE: If internal DIP switch positions 3, 4 are closed (ON), use only one pair of sense lines to monitor voltage.

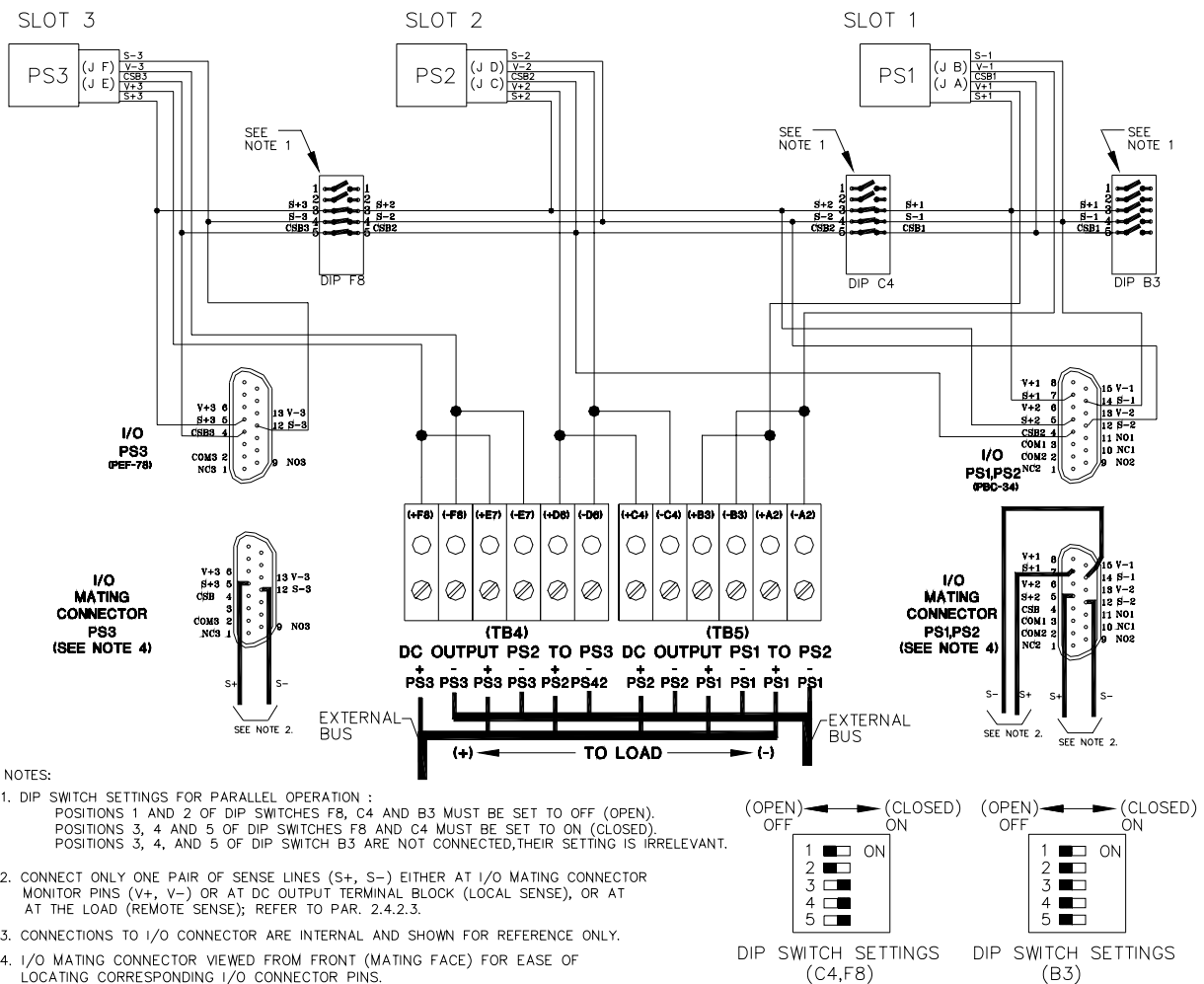
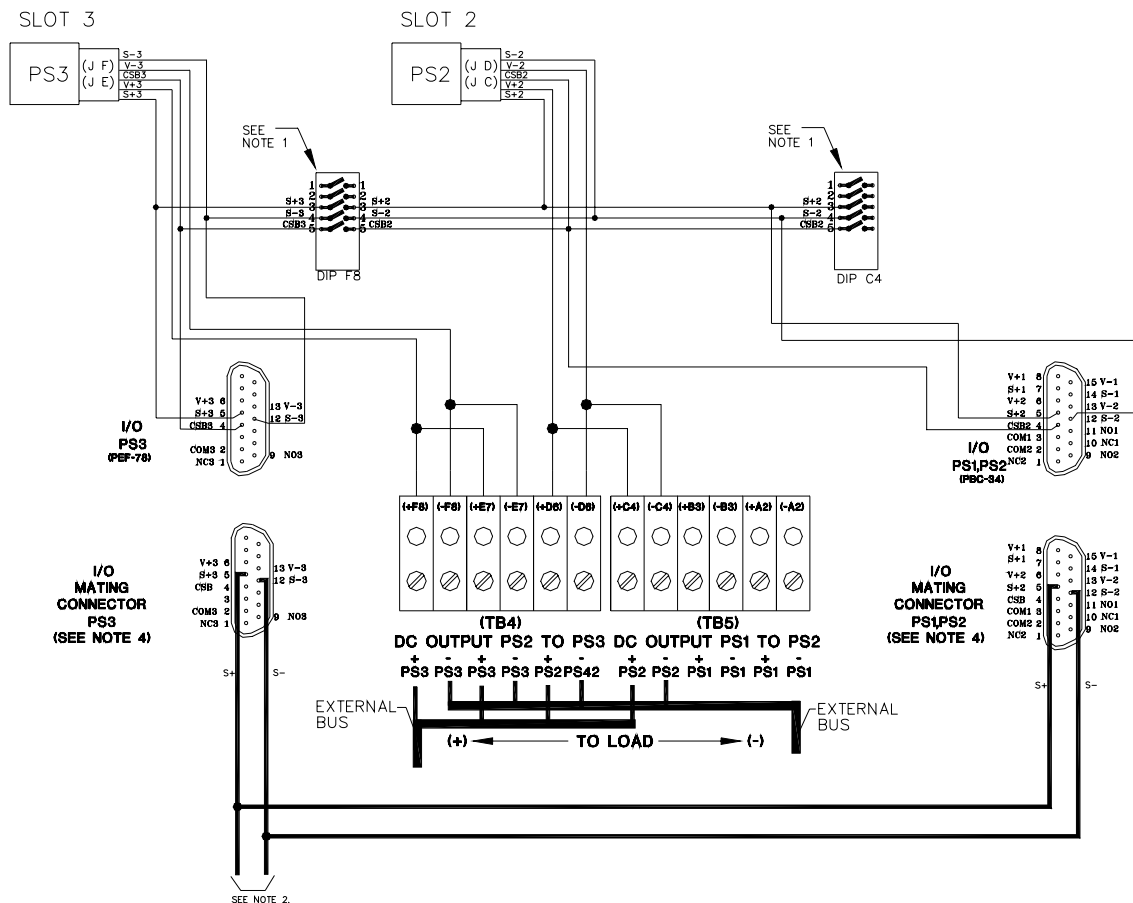

FIGURE 2-5. PARALLEL OUTPUTS USING INTERNAL DIP SWITCHES TO PARALLEL SENSE LINES AND CURRENT SHARE, PS1, PS2 AND PS3 (TYPICAL), SIMPLIFIED DIAGRAM

2.4.2.2.2 PARALLEL CURRENT SHARE - EXTERNAL WIRING

The Current Share lines for each supply must be connected together at the I/O mating connector (pin 4) using external wiring (see Figure 2-6). Figure 2-6 is a simplified diagram of a typical parallel configuration using external wiring at the I/O mating connector. Only slots 2 and 3 can be configured for parallel operation using external wiring. Position 5 of the associated DIP switch must be set to OFF (open).



NOTES:

- DIP SWITCH SETTINGS FOR PARALLEL OPERATION ,EXTERNAL WIRING:
POSITIONS 1 AND 2 OF DIP SWITCHES F8 AND C4 MUST BE SET TO OFF (OPEN).
POSITIONS 3, 4 AND 5 OF DIP SWITCHES F8 AND C4 MUST BE SET TO OFF (OPEN).
- CONNECT ONLY ONE PAIR OF SENSE LINES (S+, S-) EITHER AT I/O MATING CONNECTOR MONITOR PINS (V+, V-) OR AT DC OUTPUT TERMINAL BLOCK (LOCAL SENSE), OR AT AT THE LOAD (REMOTE SENSE); REFER TO PAR. 2.4.2.3.
- CONNECTIONS TO I/O CONNECTOR ARE INTERNAL AND SHOWN FOR REFERENCE ONLY.
- I/O MATING CONNECTOR VIEWED FROM FRONT (MATING FACE) FOR EASE OF LOCATING CORRESPONDING I/O CONNECTOR PINS.



DIP SWITCH SETTINGS (B3,C4,F8)

3041882

FIGURE 2-6. PARALLEL OUTPUTS USING EXTERNAL WIRING, TYPICAL CONFIGURATION, SIMPLIFIED DIAGRAM

2.4.2.3 SENSE CONNECTIONS FOR PARALLEL CONFIGURATIONS

NOTE: HSF power supply sense lines **MUST** be connected to the respective output terminals; otherwise the power supplies will not work.

For parallel configurations the sense lines must be connected in parallel. This can be accomplished either by using the DIP switches (positions 3 and 4 set to ON) or by setting the DIP switch positions 3 and 4 to OFF and using external wires. When configuring units to work in parallel, the current share bus (PAR. 2.4.2.2) must also be configured.

For local sensing (at the rack adapter) connect the sense lines in parallel using either the DIP switches or external jumpers, then connect one +S and one –S from the I/O mating connector to the DC OUTPUT terminal block using short jumpers.

For remote sensing (at the load) connect the sense lines in parallel using either the DIP switches or external jumpers to connect the sense lines in parallel, then connect one +S and one –S from the I/O connector to the load using external wires.

For both local and remote sensing Positions 1 and 2 of *each* DIP switch in the parallel configuration must be set to OFF (open); refer to Figure 2-1 to identify the DIP switch associated with a corresponding slot.

See the following paragraphs for more details:

- PAR. 2.4.2.3.1: Parallel configurations using DIP switches to connect the sense lines in parallel and external wires to configure local sensing.
- PAR. 2.4.2.3.2: Parallel configurations using external wires to connect the sense lines in parallel and external wires to configure local sensing.
- PAR. 2.4.2.3.3: Parallel configurations using DIP switches to connect the sense lines in parallel and external wires to configure remote sensing.
- PAR. 2.4.2.3.4: Parallel configurations using external wires to connect the sense lines in parallel and external wires to configure remote sensing.

2.4.2.3.1 PARALLEL CONFIGURATION USING DIP SWITCHES TO CONNECT SENSE LINES IN PARALLEL AND EXTERNAL WIRES TO CONFIGURE LOCAL SENSING

Figure 2-7 is a simplified diagram of a typical parallel configuration using local sensing via external wires to connect V(+) to S(+), V(-) to S(-) and DIP switch settings to connect the sense leads in parallel. This configuration requires the following:

1. For each supply in parallel set DIP switch positions 1 and 2 to OFF (open) (see Figure 2-1).
2. For each DIP switch between parallel-connected slots (C4 and F8), set DIP switch positions 3 and 4 to ON (closed) to connect sense leads in parallel (see Figure 2-1).
3. For each DIP switch between parallel-connected slots configure position 5 to connect the current share bus by referring to PAR. 2.4.2.2.
4. Locate DIP switch(es) at end of the parallel group and set positions 3, 4, and 5 to OFF (open) to isolate the group. (see Figure 2-1).
5. Configure Positions 6, 7, and 8 (alarms) of each DIP switch per PAR. 2.4.4.
6. Connect wire between I/O mating connector pin Sense (+) and corresponding power supply V(+) terminal at DC OUTPUT terminal block.
7. Connect wire between I/O mating connector pin Sense (-) and corresponding power supply V(-) terminal at DC OUTPUT terminal block.

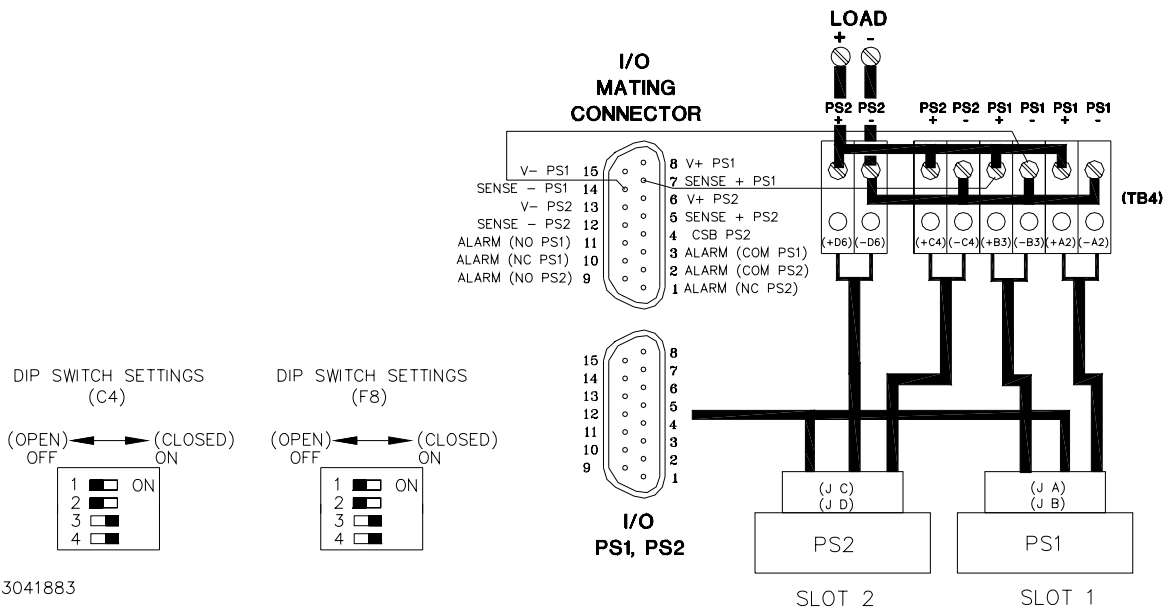

3041883

FIGURE 2-7. TYPICAL PARALLEL CONNECTIONS, LOCAL SENSING (EXTERNAL), EXTERNAL WIRES AND DIP SWITCHES

2.4.2.3.2 PARALLEL CONFIGURATIONS USING EXTERNAL WIRES TO CONNECT SENSE LINES IN PARALLEL AND EXTERNAL WIRES TO CONFIGURE LOCAL SENSING

Figure 2-8 is a simplified diagram of a typical parallel configuration using local sensing via external wires to connect V(+) to S(+), V(-) to S(-) and jumpers connected to the I/O mating connector to connect the sense leads in parallel. This configuration requires the following:

1. For each supply in parallel set DIP switch positions 1 and 2 to OFF (open) (see Figure 2-1).
2. For each DIP switch between parallel-connected slots (C4 and F8), set DIP switch positions 3 and 4 to OFF (open) (sense leads will be connected in parallel in steps 8 and 9) (see Figure 2-1).
3. For each DIP switch between parallel-connected slots configure position 5 to connect the current share bus by referring to PAR. 2.4.2.2.
4. Locate DIP switch(es) at end of the parallel group and set positions 3, 4, and 5 to OFF (open) to isolate the group. (see Figure 2-1).
5. Configure Positions 6, 7, and 8 (alarms) of each DIP switch per PAR. 2.4.4.
6. Connect wire between I/O mating connector pin Sense (+) and corresponding power supply V (+) terminal at DC OUTPUT terminal block.
7. Connect wire between I/O mating connector pin Sense (-) and corresponding power supply V (-) terminal at DC OUTPUT terminal block.
8. Connect short jumper across I/O mating connector Sense (+) pins.
9. Connect short jumper across I/O mating connector Sense (-) pins.

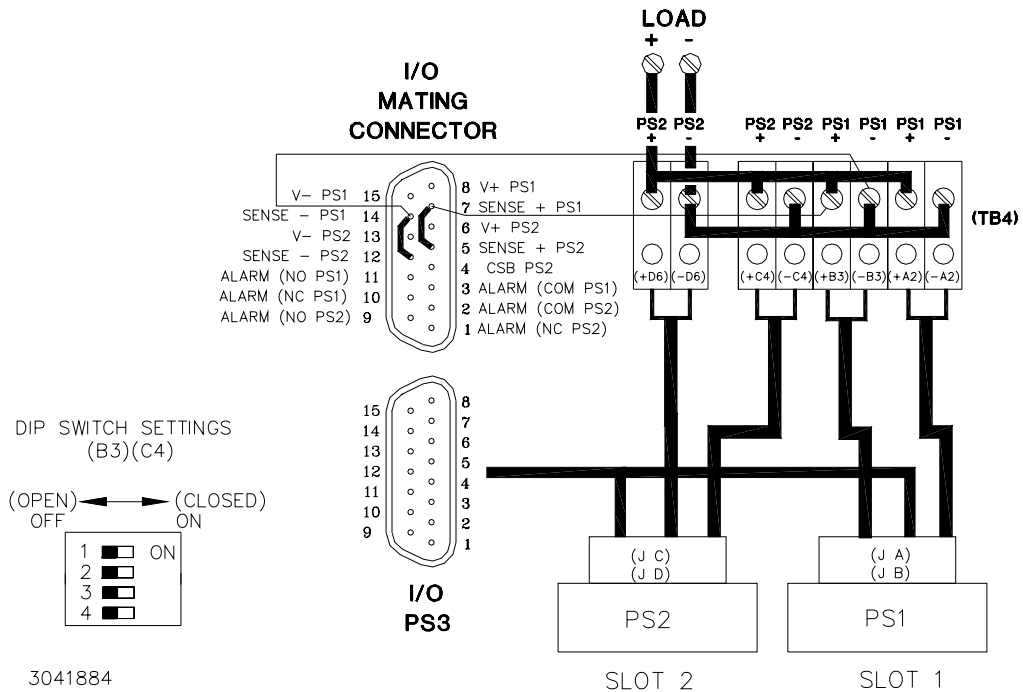
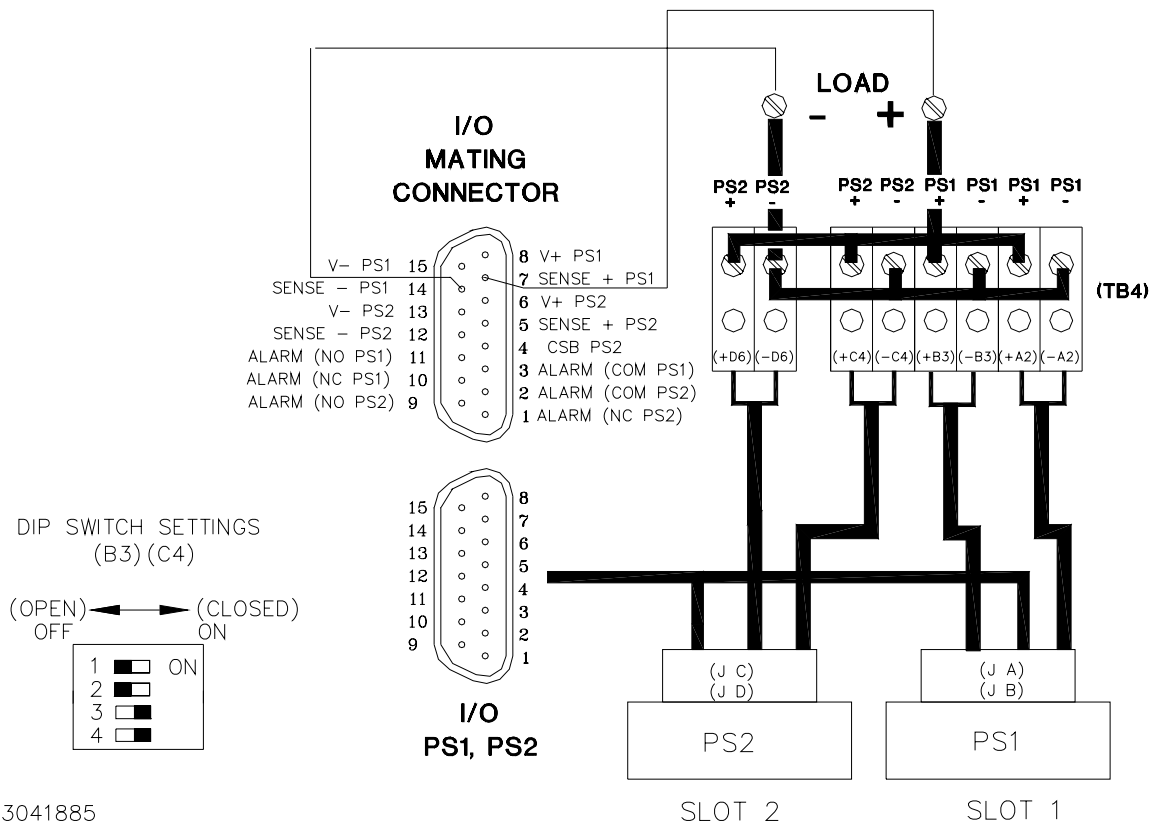

FIGURE 2-8. TYPICAL PARALLEL CONNECTIONS, LOCAL SENSING (EXTERNAL), EXTERNAL WIRES AND I/O MATING CONNECTOR JUMPERS

2.4.2.3.3 PARALLEL CONFIGURATIONS USING DIP SWITCHES TO CONNECT SENSE LINES IN PARALLEL AND EXTERNAL WIRES TO CONFIGURE REMOTE SENSING

Figure 2-9 is a simplified diagram of a typical parallel configuration using remote sensing via external wires to connect V(+) to S(+), V(-) to S(-) and DIP switch settings to connect the sense leads in parallel. This configuration requires the following:

1. For each supply in parallel set DIP switch positions 1 and 2 to OFF (open) (see Figure 2-1).
2. For each DIP switch between parallel-connected slots (C4 and F8), set DIP switch positions 3 and 4 to ON (closed) to connect sense leads in parallel (see Figure 2-1).
3. For each DIP switch between parallel-connected slots configure position 5 to connect the current share bus by referring to PAR. 2.4.2.2.
4. Locate DIP switch(es) at ends of the parallel group and set positions 3, 4, and 5 to OFF (open) to isolate the group (see Figure 2-1).
5. Configure Positions 6, 7, and 8 (alarms) of each DIP switch per PAR. 2.4.4.
6. Connect wire from I/O mating connector Sense (+) pin to V (+) at the load.
7. Connect wire from I/O mating connector Sense (-) pin to V (-) at the load.



3041885

FIGURE 2-9. TYPICAL PARALLEL CONNECTIONS, REMOTE SENSING USING DIP SWITCHES TO PARALLEL SENSE WIRES

2.4.2.3.4 PARALLEL CONFIGURATIONS USING EXTERNAL WIRES TO CONNECT SENSE LINES IN PARALLEL AND EXTERNAL WIRES TO CONFIGURE REMOTE SENSING

Figure 2-10 is a simplified diagram of a typical parallel configuration using remote sensing via external wires to connect V(+) to S(+), V(-) to S(-) and jumpers connected to the mating connector to connect the sense leads in parallel. This configuration requires the following:

1. For each supply in parallel set DIP switch positions 1 and 2 to OFF (open) (see Figure 2-1).
2. For each DIP switch between parallel-connected slots (C4 and F8), set DIP switch positions 3 and 4 to OFF (open) (sense leads will be connected in parallel in steps 8 and 9) (see Figure 2-1).
3. For each DIP switch between parallel-connected slots, configure position 5 to connect the current share bus by referring to PAR. 2.4.2.2.
4. Locate DIP switch(es) at both ends of the parallel group and set positions 3, 4, and 5 to OFF (open) to isolate the group (see Figure 2-1).
5. Configure Positions 6, 7, and 8 (alarms) of each DIP switch per PAR. 2.4.4.
6. Connect short jumper across I/O mating connector Sense (+) pins.
7. Connect short jumper across I/O mating connector Sense (-) pins.
8. Connect wire from I/O mating connector Sense (+) pin to V (+) at the load.
9. Connect wire from I/O mating connector Sense (-) pin to V (-) at the load.

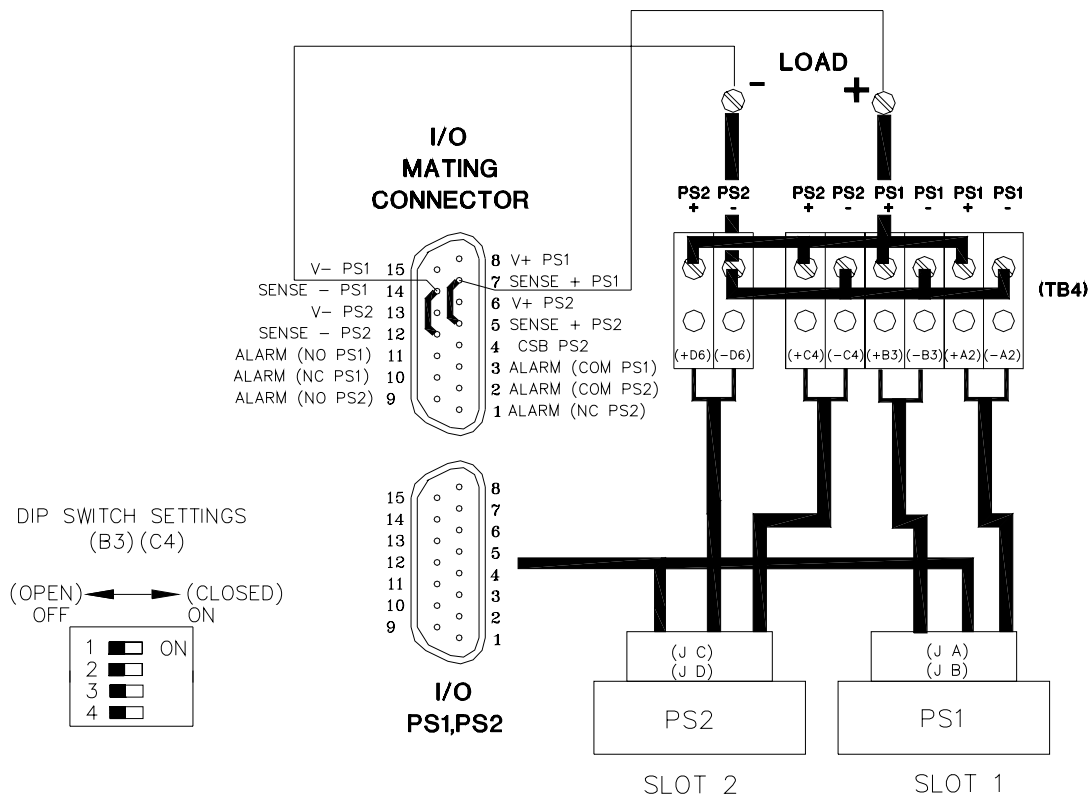

3041886

FIGURE 2-10. TYPICAL PARALLEL CONNECTIONS, REMOTE SENSING USING I/O MATING CONNECTOR JUMPERS TO PARALLEL SENSE WIRES

2.4.3 SERIES OPERATION

HSF power supplies may be connected in series to obtain higher output voltages, however the maximum current must be limited to 35A, the maximum allowable through the internal circuits of the rack adapter. Series configurations can only be accomplished by **external wiring** of the I/O mating connector. Blocking diodes are incorporated in the HSF power supplies. V+ of one supply must be connected to V- of the next supply at the DC OUTPUT terminal block.

DIP switches (positions 1 through 5) *between* series-connected supplies and at both ends of the series-connected group must be set to OFF (open). Sensing can be either local or remote (PAR. 2.4.1.3). Local sensing requires external wiring (PAR.2.4.1.2). Figure 2-11 illustrates PS4, PS5 and PS6 connected in series.

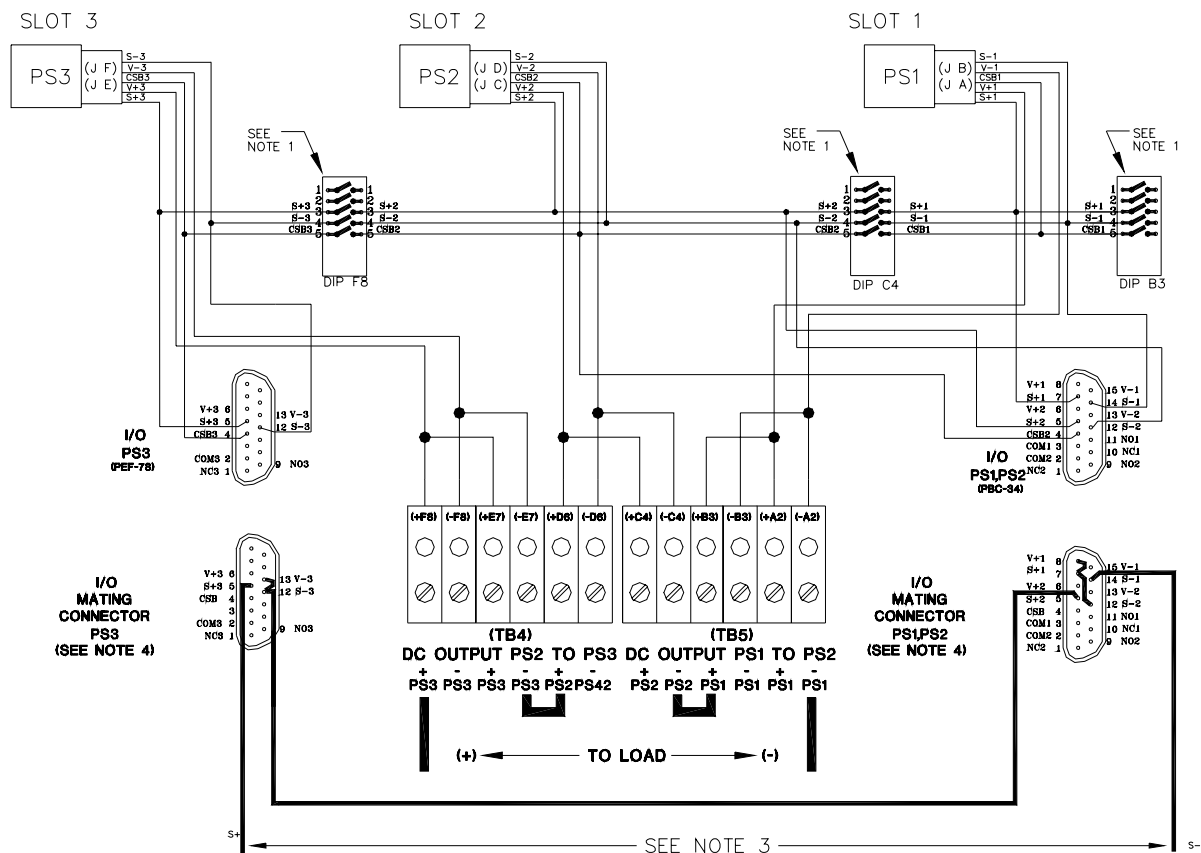

NOTES:

1. DIP SWITCH SETTINGS FOR SERIES OPERATION :
POSITIONS 1 THROUGH 5 OF DIP SWITCHES F8, C4 AND B3 MUST BE SET TO OFF (OPEN).
2. CONNECTIONS TO I/O CONNECTOR ARE INTERNAL AND SHOWN FOR REFERENCE ONLY.
3. S+ AND S- LINES MUST BE CONNECTED TO (+) OUT AND (-) OUT RESPECTIVELY. THIS CAN BE DONE EITHER AT THE DC OUTPUT TERMINALS OR AT THE I/O MATING CONNECTOR (LOCAL SENSING) OR AT THE LOAD (REMOTE SENSING); REFER TO PAR.2.4.1.3.
4. I/O MATING CONNECTOR VIEWED FROM FRONT (MATING FACE) FOR EASE OF LOCATING CORRESPONDING I/O CONNECTOR PINS.

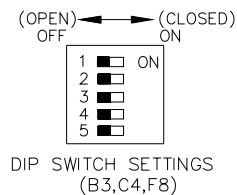

3041887

FIGURE 2-11. SERIES CONFIGURATION, SIMPLIFIED DIAGRAM

2.4.4 ALARM CONFIGURATIONS

The HSF Power Supplies each provide a normally closed (N.C.) and normally open (N.O.) line referenced to common (COM) for use as an alarm at the users discretion. The N.C. line opens upon failure, the N.O. line closes upon failure. The RA 19-3B is configured at the factory for independent operation of these lines. It is possible to configure these alarm lines to allow multiple power supplies to provide a failure indication using the N.O. (close on failure) lines, N.C (open on failure) lines, or both. Each alarm circuit can be configured in two ways: either by internal DIP switches or by external wiring of the I/O mating connector. Use external wiring of the I/O mating connector if DIP switch specifications noted in the following CAUTION will be exceeded.

CAUTION: The user is responsible for ensuring that the alarm circuit does not exceed the HSF alarm relay switching specifications: 1A @ 30V d-c or 0.5A @ 125V a-c. If the alarm circuit is configured using the rear panel DIP switches, the user is responsible for ensuring that the alarm circuit does not exceed DIP switch specifications: 100mA, 50V d-c, maximum.

2.4.4.1 N.O. ALARM LINE (CLOSE ON FAILURE)

The N.O. and COM line of each HSF supply provide a closed contact (short circuit) upon failure. To configure multiple power supplies so that a failure of any supply produces a failure indication, it is necessary to connect the N.O. lines in parallel and the COM lines in parallel.

2.4.4.1.1 CLOSE ON FAILURE USING INTERNAL DIP SWITCHES

Close on failure for multiple power supplies can be accomplished by setting DIP switch positions 6 and 7 to ON (closed). associated with each adjacent slot included in the alarm circuit. For example, for PS1 and PS2, set DIP switch 2, positions 6 and 7 to ON (closed). The failure indication (short circuit) will be present across both N.O.1 and COM1, and N.O.2 and COM2. Figure 2-12 is a simplified diagram illustrating a close on failure alarm configuration for six power supplies using internal DIP switches.

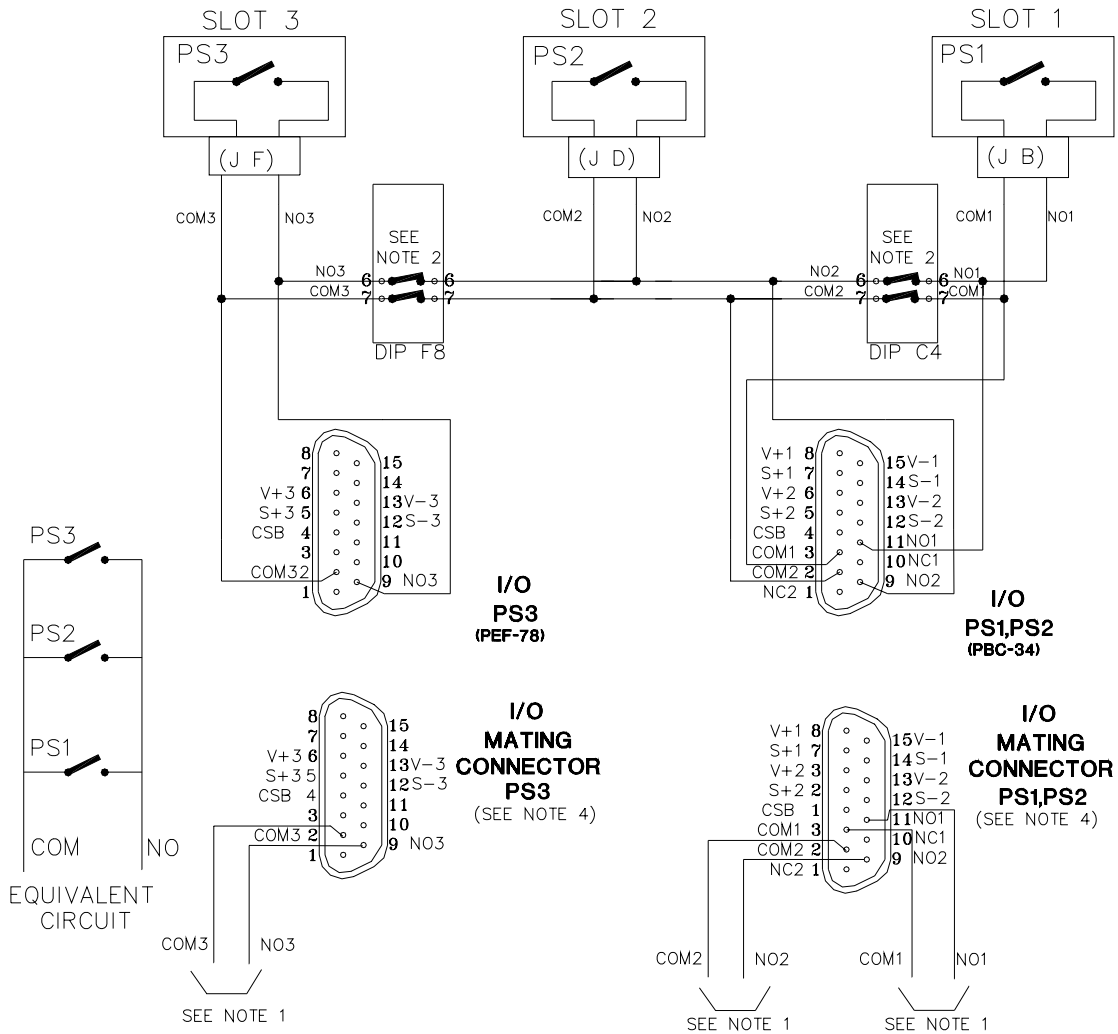

- NOTES:
1. USE ANY PAIR OF NO() AND COM() LINES FOR CLOSE ON FAILURE ALARM.
 2. SET ALL ASSOCIATED DIP SWITCHES, POSITIONS 6 AND 7, TO ON (CLOSED).
 3. CONNECTIONS TO I/O CONNECTOR ARE INTERNAL AND SHOWN FOR REFERENCE ONLY.
 4. I/O MATING CONNECTOR VIEWED FROM FRONT (MATING FACE) FOR EASE OF LOCATING CORRESPONDING I/O CONNECTOR PINS.

3041888

FIGURE 2-12. CLOSE ON FAILURE ALARM CONFIGURATION USING INTERNAL DIP SWITCHES, SIMPLIFIED DIAGRAM

2.4.4.1.2 CLOSE ON FAILURE USING EXTERNAL WIRING AT I/O MATING CONNECTOR

Close on failure for multiple power supplies can be accomplished by wiring N.O. and COM in parallel at the I/O mating connector. DIP switches associated with slots included in the alarm circuit must have positions 6 and 7 set to OFF (open). The failure indication (short circuit) will be present across any pair of N.O. and COM lines. Figure 2-13 is a simplified diagram illustrating a close on failure alarm configuration for six power supplies using external wiring at the I/O mating connector.

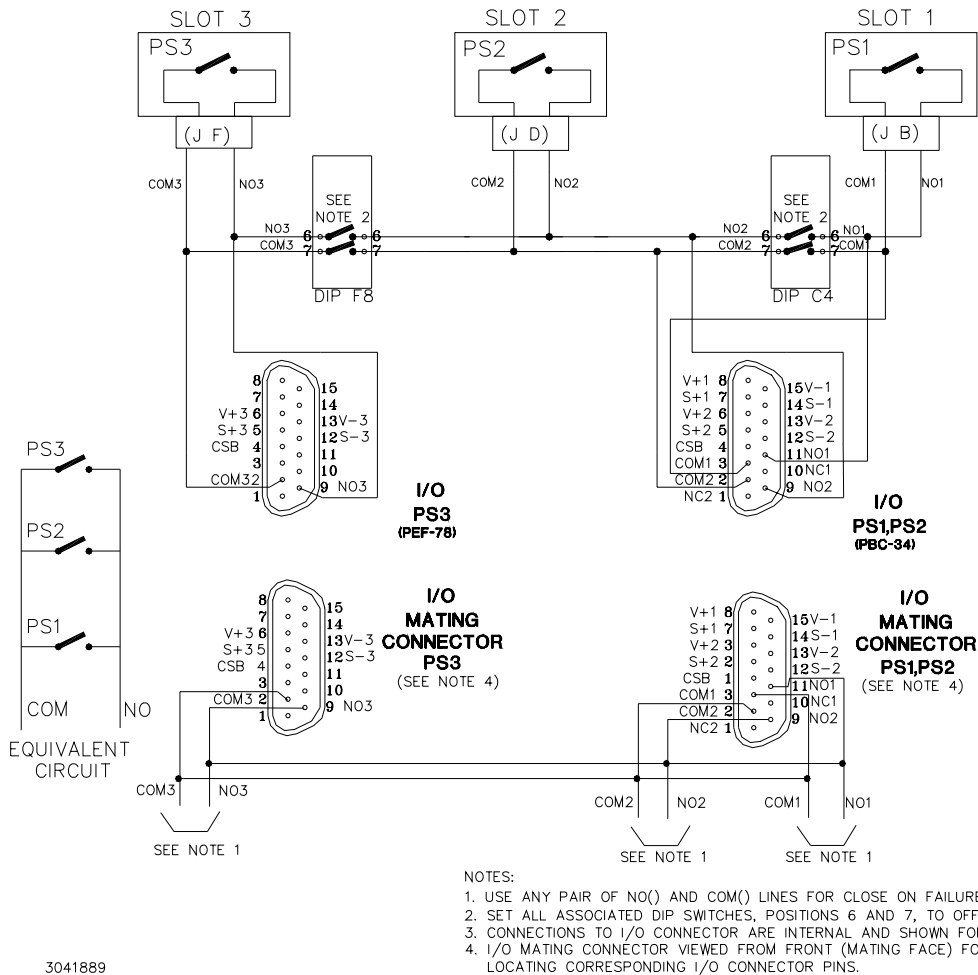

FIGURE 2-13. CLOSE ON FAILURE ALARM CONFIGURATION USING EXTERNAL WIRING AT I/O MATING CONNECTOR, SIMPLIFIED DIAGRAM

2.4.4.2 N.C. ALARM LINE (OPEN ON FAILURE)

The N.C. and COM line of each HSF supply provide an open contact (open circuit) upon failure. To configure multiple power supplies so that a failure of any supply produces a failure indication, it is necessary to connect the N.C. line of one, with the COM line of the next power supply, so the alarm line is connected in series.

2.4.4.2.1 OPEN ON FAILURE USING INTERNAL DIP SWITCHES

The open on failure alarm for multiple power supplies is accomplished by setting the associated DIP switch, position 8, to ON (closed) for each slot included in the alarm circuit as indicated in Figure 2-14. Setting DIP switch position 8 to ON (closed) connects the N.C. line to the COM line of the adjacent power supply. Figure 2-14 illustrates an open on failure alarm configuration for six power supplies using internal DIP switch settings.

CAUTION: The user is responsible for ensuring that the alarm circuit does not exceed DIP switch specifications: 100mA, 50V d-c, maximum.

To configure PS1, PS2 and PS3 as open on failure, set position 8 of DIP switch for slot 2 (C4) and slot 3 (F8) to ON (closed). The failure indication (open circuit) will be present across N.C.3 and COM 1.

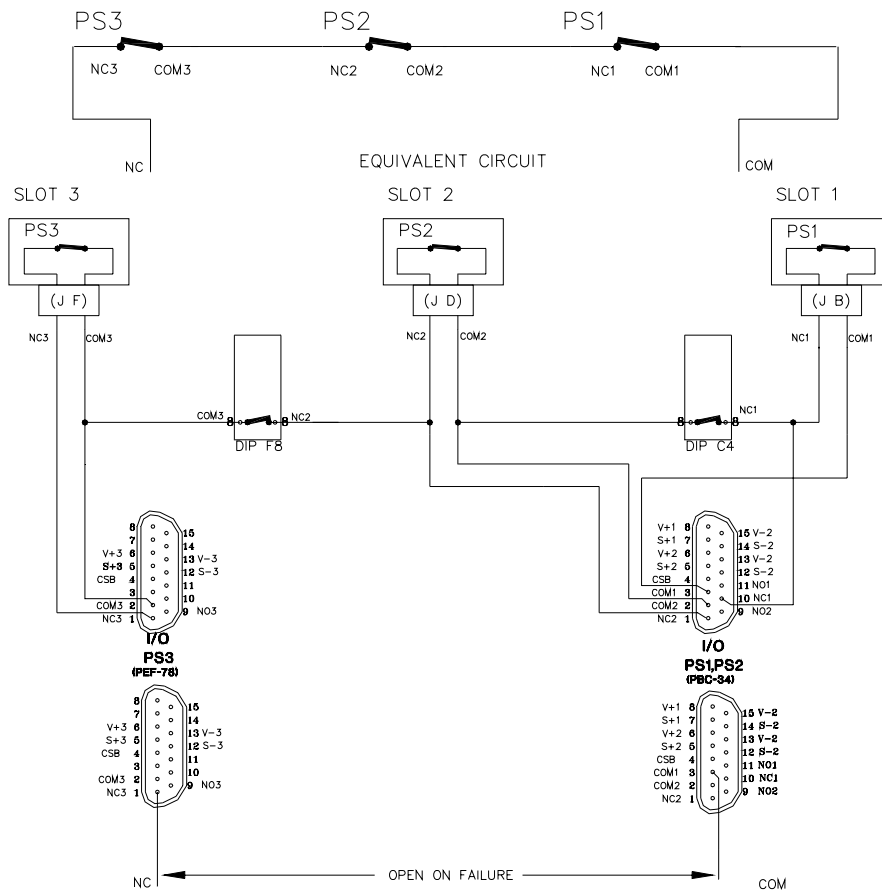

- NOTES:
1. SET POSITION 8 OF SPECIFIED DIP SWITCHES TO ON (CLOSED).
 2. CONNECTIONS TO I/O CONNECTOR ARE INTERNAL AND SHOWN FOR REFERENCE ONLY.
 3. I/O MATING CONNECTOR VIEWED FROM FRONT (MATING FACE) FOR EASE OF LOCATING CORRESPONDING I/O CONNECTOR PINS.

3041890

FIGURE 2-14. OPEN ON FAILURE ALARM CONFIGURATION USING INTERNAL DIP SWITCHES, SIMPLIFIED DIAGRAM

2.4.4.2.2 OPEN ON FAILURE USING EXTERNAL WIRING OF I/O MATING CONNECTOR

Figure 2-15 illustrates an open on failure alarm configuration using external wiring of the I/O mating connectors for six power supplies. It is necessary to set DIP switch position 8 to OFF (open) for each slot included in the open on failure alarm circuit.

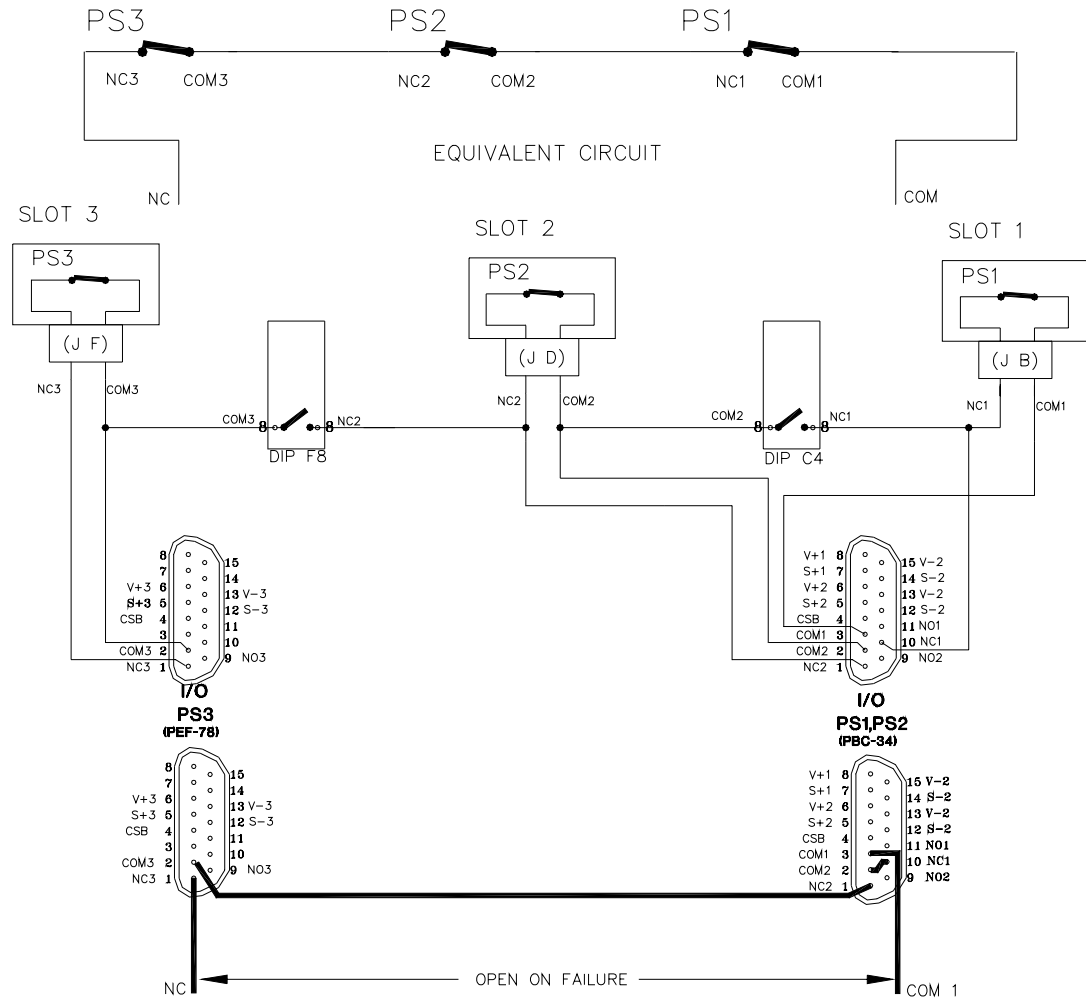

NOTES:

1. SET POSITION 8 OF SPECIFIED DIP SWITCHES TO OFF (OPEN).
2. CONNECTIONS TO I/O CONNECTOR ARE INTERNAL AND SHOWN FOR REFERENCE ONLY.
3. I/O MATING CONNECTOR VIEWED FROM FRONT (MATING FACE) FOR EASE OF LOCATING CORRESPONDING I/O CONNECTOR PINS.

3041891

FIGURE 2-15. OPEN ON FAILURE ALARM CONFIGURATION USING EXTERNAL WIRING AT I/O MATING CONNECTOR, SIMPLIFIED DIAGRAM

2.5 TERMINATIONS

All input, output and control terminations are located on the rear panel of the rack adapter (see Figure 1-4).

2.6 COOLING

The HSF power supplies mounted within the rack adapter are maintained within their operating temperature range by means of convection cooling. ALL OPENINGS AROUND THE RACK ADAPTER CASE MUST BE KEPT CLEAR OF OBSTRUCTION TO ENSURE PROPER AIR CIRCULATION. Care must be taken that the ambient temperature, which is the temperature of the air immediately surrounding the rack adapter, does not rise above the specified limits for the operating load conditions of the installed HSF power supplies. Kepco recommends providing additional space above and below the rack adapter where possible when the rack adapter is fully populated.

2.7 INSTALLATION (Refer to "Mechanical Outline Drawing," Figure 1-5.)

The rack adapter mounts directly to EIA standard 19" racks via the two mounting ears; two screws are required per mounting ear for proper support.

Provide adequate clearance around case and ensure that the temperature immediately surrounding the unit does not exceed the maximum specified ambient temperature for the operating conditions of the installed power supplies.

CAUTION

RACK ADAPTER SHOULD BE MOUNTED BEFORE INSTALLING POWER SUPPLIES.

2.8 WIRING INSTRUCTIONS

Interconnections between an a-c power source and a stabilized power supply, and between the power supply and its load are as critical as the interface between other types of electronic equipment. If optimum performance is expected, certain rules for the interconnection of source, power supply and load must be observed by the user. These rules are described in detail in the following paragraphs and in the operating instructions for HSF Series power supplies.

2.8.1 SAFETY GROUNDING

Local, national and international safety rules dictate the grounding of the metal cover and case of any instrument connected to the a-c power source, when such grounding is an intrinsic part of the safety aspect of the instrument. The instructions below suggest wiring methods which comply with these safety requirements; however, in the event that the specific installation for the power system involves differences with the recommended wiring, it is the customer's responsibility to ensure that all applicable electric codes for safety grounding requirements are met.

2.8.2 SOURCE POWER CONNECTIONS

CAUTION

THE SERIES RA 19-(X)B DOES NOT INCORPORATE ANY SAFETY INTERRUPT DEVICES. PROTECTION OF INPUT WIRING REQUIRES USER-CONFIGURED SAFETY INTERRUPTS.

When used in conjunction with Kepco HSF series power supplies, these rack adapters can be operated from single phase 95-264V a-c or 125-370V d-c source power without adjustment or modification. Source power is applied to two 3-terminal terminal blocks at the rear panel and distributed as indicated in Figure 1-3. Wires must be sized according to expected current. Wire size range is 20-10 AWG; torque to 6 lb-in (0.6 N•M) maximum. The terminal positions are labeled L, N, and G. Their functions are:

- **Terminal G (Ground)** is the safety ground connection for the Series RA 19-(X)B. It is connected to the Series RA 19-(X)B chassis and to the safety ground terminal of the input power connector for each of the power supply mounting positions via the PCB backplane. Terminal G must be connected to safety ground in order to ensure proper grounding of the HSF power supplies.
- **Terminals L (Line Phase) and N (Neutral)** are connected to the input power entry connectors. Source power is provided to the power supplies indicated by the label on the rear panel. The source power connectors are independent of each other, allowing the user complete flexibility in wiring for common or redundant input power configurations.

The following standard wiring configuration is recommended by Kepco as being compliant with applicable national and international safety standards. Please consult local electrical codes for wire current ratings and other specific requirements:

- Connect Terminal G of each Series RA 19-(X)B input power terminal block to safety ground
- Connect a separate wire pair from each side of the input power to the L/N terminal pair of the input power terminal block.
- Where 115V a-c source power is used, Kepco recommends the use of the line cords, P/N 118-0506 supplied (North American style plug, 15A maximum, 6 ft. long).
- Wire size is determined by the maximum rated source current for each HSF power supply and the number of power supplies installed. For lower system power configurations, smaller wire can be used; contact Kepco Applications Engineering for assistance.

2.8.3 CONTROL SIGNAL CONNECTIONS

Access to the control signal (I/O) connector for each HSF power supply is provided via the 15-pin D-subminiature connectors on the rear panel of the rack adapter (see Figure 1-4). Two mating connectors (Kepco P/N 142-0449) are provided in a plastic bag. Consult PAR. 2.4 and the HSF operator's manual for instructions on wiring and use of these control lines.

2.8.4 OUTPUT LOAD CONNECTIONS

Load connections to the rack adapters are achieved via two terminal blocks located on the backplate assembly. Wires must be sized according to expected current. Wire size range is 20-10 AWG; torque to 6 lb-in (0.6 N•M) maximum. (Sensing connections are made through the I/O mating connector, PAR. 2.4.1)

NOTE!

REGARDLESS OF OUTPUT CONFIGURATION, OUTPUT SENSE LINES MUST BE PROPERLY CONNECTED FOR OPERATION.

2.8.4.1 PARALLEL/REDUNDANT OPERATION

**WARNING**

Removal of an HSF power supply from a “live” system must be done only by authorized service personnel after HSF power switch is set to OFF. Dangerous voltages may be accessible through the open slot after a power supply is removed.

Identical HSF power supplies can be connected in parallel to provide redundant operation or increased output current to a common load. Maximum output current for each terminal pair of the DC OUTPUT terminal blocks is 35 Amperes. Connect (+) to (+) and (–) to (–) at the DC OUTPUT terminal block (see Figure 2-5).

NOTE: Verify that the sense lines and current share bus are configured per PAR. 2.4.2. An external bus is required where current exceeds 35 Amperes.

2.8.4.2 SERIES/INDEPENDENT OPERATION

The rack adapter can be used for either independent or series operation of HSF power supplies; it is factory configured for independent operation using local sensing. To select remote sensing, refer to PAR. 2.4.1.3.

For series operation, connect (+) and (–) terminals at the DC OUTPUT terminal block of power supplies to be connected in series (see Figure 2-11). The HSF power supplies are equipped with blocking diodes which allow series operation without further modification. The RA 19-(X)B Series rack adapter is designed to safely handle a maximum output voltage of 500 Volts.

2.8.4.3 MIXED OPERATION

The design of the Series RA 19-(X)B rack adapters permits the user to configure HSF power supplies for almost any combination of independent, series and parallel operation, both within a single rack adapter and between different RA 19-(X)B rack adapters, within the limits of the HSF operation envelope and the current and voltage ratings specified in PAR.s 2.8.4.1 and 2.8.4.2. The user must ensure that the requirements for each configuration stated above are met. If any questions or problems arise, the user is encouraged to contact the Kepco Applications Engineering group for technical assistance.

2.9 INSTALLING/REMOVING HSF POWER SUPPLIES

**WARNING**

Removal of an HSF power supply from a “live” system must be done only by authorized service personnel after HSF power switch is set to OFF. Dangerous voltages may be accessible through the open slot after a power supply is removed.

Refer to Figure 1-1, for proper slot positions applicable to the RA 19-3B Rack Adapter. Insert HSF power supply in selected slot until power supply front panel is flush with rack adapter chassis and secure with two phillips screws on power supply.

2.10 SHIPPING

The rack adapter may be shipped with power supplies installed *only* after the HSF power supplies have been securely fastened to the rack adapter (PAR. 2.9). Contact Kepco Applications Engineering if further assistance is required.

You must register your product to comply with the terms of the warranty. Either fill out the form below and mail or fax to Kepco, or for rapid on-line registration go to:

<http://www.kepcopower.com/warranty.htm>

PRODUCT PURCHASED:

Model Number) _____
Serial Number _____

PURCHASE INFORMATION:

Date Purchased: _____
Date Received: _____

REQUEST ADDITIONAL INFORMATION

- Send complete Catalog
- Have Sales Engineer Call
- Contact via: E-Mail Telephone Fax S-mail

REGISTER TO:

Registered by: _____
Company Name: _____
Street: _____
City: _____
State: _____
Country: _____
Zip: _____
E-mail: _____
FAX: _____
Phone: _____

WHAT INFLUENCED YOUR CHOICE OF THIS POWER SUPPLY?

- Previous Experience (which Kepco Models do you have?)

- Magazines (which ones?) _____

- Trade Shows (which ones?) _____
- Directory? _____

- Kepco Catalog or Brochure? _____
- Sales Representative?
- Web Site
- Other (please explain): _____

What products would you like to see Kepco make?

CUT HERE

Kepco 5 Year Warranty

This is to certify that we, KEPSCO, INC., (hereinafter called "Company"), Flushing, NY 11355 USA, warrants for a period of FIVE YEARS, this instrument known as:

MODEL: _____

SERIAL NO. _____

The Company's products are warranted for a period of five years from date of delivery to be free from defects in materials and workmanship and to conform to the specifications furnished or approved by the Company. Liability under this warranty shall be limited to the repair or replacement of any defective product at Company's option.

If any defect within this warranty appears within the warranty period, the Purchaser shall promptly notify the Company in writing. No material will be accepted for repair or replacement without written authorization of the Company.

Upon such authorization, and in accordance with instructions of the Company, parts or materials for which replacement is requested shall be returned to the Company for examination, with shipping charges prepaid by the Purchaser. Final determination as to whether a product is actually defective rests with the Company.

This warranty does not extend to any product which has been subjected to misuse, neglect, accident, improper installation, or use in violation of instructions furnished by the Company. The warranty does not extend to, or apply to, any unit which has been repaired or altered outside of the Company's factory by persons not expressly approved by the Company.

THE WARRANTY HEREIN CONTAINED IS IN LIEU OF AND EXCLUDES ALL OTHER WARRANTIES, EXPRESS, IMPLIED OR STATUTORY, INCLUDING WITHOUT LIMITATION THE WARRANTY OF MERCHANTABILITY.

THIS KEPSCO PRODUCT IS WARRANTED FOR FIVE YEARS!

KEPCO, INC. • 131-38 SANFORD AVENUE, FLUSHING,
NY 11355 USA • Tel. 718-461-7000 • Fax. 718-767-1102
E-mail: hq@kepcopower.com • URL: <http://www.kepcopower.com>



FOLD HERE

Please
place
stamp
here

KEPCO, INC.

131-38 SANFORD AVE.
FLUSHING, NY 11355 USA

CUT HERE