

INSTRUCTION MANUAL

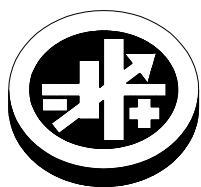

KEPCO An ISO 9001 Company.



100 WATT SINGLE OUTPUT SWITCHING POWER SUPPLIES

**CAUTION: UNIT IS SET
TO 115V AC OPERATION**

I — INTRODUCTION

SCOPE OF MANUAL. This instruction manual covers the installation and operation of the Kepco RAX 100W Series of Switching Power Supplies. For service information, please refer to the Service Manual for the RAX 100W Series, which can be purchased either from your Kepco Representative, or by writing directly to: Kepco Inc. 131-38 Sanford Avenue, Flushing, New York 11352, U.S.A. When ordering a Service Manual, please state **Model Designation and Serial Number of your RAX power supply.** This information can be found on the nameplate of the unit.

DESCRIPTION. The Kepco RAX 100W Series consists of seven models of switching power supplies, with a single output as shown in Table 1. Units may be operated with either 115V a-c or 230V a-c 47-440Hz input. They will also operate on 240V to 370V d-c input. The RAX 100W Series employs a light weight ferrite core with 140 KHz switching frequency. Regulation is provided by pulse width modulation. A FET power stage, operating in the forward conversion mode provides a smooth isolated d-c output. A triac "soft-start" circuit prevents excessive turn-on current surge. Overvoltage protection and optically isolated remote TTL on-off control is provided. Current limiting with automatic recovery from short circuit is featured. Units are enclosed in a wrap-around aluminum case with an LED "output present" light visible on the terminal side of the case.

Table 1 contains specifications and operating limits of individual RAX 100W Series models. Section II (ollowing) contains specifications and operating limits common to all RAX 100W Series Models.

II — SPECIFICATIONS

The following specifications are at nominal input voltages at 25°C unless otherwise specified.

TABLE 1. OUTPUT RATINGS AND SPECIFICATIONS, RAX 100W SERIES

MODEL		RAX 3.3-20K	RAX 5-20K	RAX 12-8.3K	RAX 15-6.6K	RAX 24-4.2K	RAX28-3.5K	RAX 48-2K
OUTPUT VOLTS, d-c		3.3V	5V	12V	15V	24V	28V	48V
ADJUSTMENT RANGE		1.8 - 3.6V	4.0 - 5.5V	8.4 - 13.2V	12.0 - 16.5V	16.8 - 26.4V	19.6 - 30.8V	32.6 - 52.8V
MAXIMUM OUTPUT RATINGS (AMPS, WATTS)	50° C amb.	20.0A/66W	20.0A/100W	8.3A/99.6W	6.6A/99W	4.2A/100.8W	3.5A/98W	2.0A/96W
	60° C amb.	14.0A/46.2W	14.0A/70W	5.8A/69.7W	4.6A/69.3W	2.9A/70.6W	2.45A/68.6W	1.4A/67.2W
	71° C amb.	8.0A/26.4W	8.0A/40W	3.3A/39.8W	2.6A/39.8W	1.7A/40.3W	1.4A/39.2W	0.8A/38.4W
CURRENT LIMIT (AMPS) ⁽¹⁾		22.0 - 24.0	22.0 - 24.0	9.1 - 10.0	7.3 - 8.0	4.7 - 5.1	4.0 - 4.2	2.3 - 2.5
OVP RANGE (VOLTS)		3.9 - 4.8	6.0 - 6.9	13.7 - 15.7	17.0 - 19.5	27.0 - 30.5	32.0 - 35.0	55.0 - 63.0
RIPPLE AND NOISE ⁽²⁾ (mV P-P)	source (typ)	5	5	15	15	25	30	35
	source (max)	10	10	30	30	40	60	90
	switching (typ)	25	25	25	25	25	25	25
	switching (max)	40	40	50	50	60	60	60
	spike noise (max) ⁽³⁾	100	100	170	200	290	330	530

(1) Change of current setting with the specified variations for operating temperatures and source input voltage is within ±10% of the rated values.

(2) Source component 2x source frequency, and switching component approximately 140KHz.

(3) Measured with a 50 MHz bandwidth.

INPUT VOLTAGE: (Jumper selectable, see Section III, FIG. 3):

120V a-c nominal, range: 85 -132V a-c

220-240V a-c nominal, range: 170 -264V a-c

320V d-c nominal, range: 240 -370V d-c

For d-c input the jumper is placed in the 230V position.

INPUT SOURCE FREQUENCY:

Nominal 50/60 Hz; Range 47-440 Hz. (At 440 Hz the leakage current exceeds the VDE safety specification limit.)

BROWNOUT VOLTAGE:

115V a-c input selection, 80V a-c min. (82V a-c min. for model RAX 28-3.5K)
 230V a-c input selection, 160V a-c min. (164V a-c min. for model RAX 28-3.5K)
 320V d-c input selection, 220V d-c min. (Jumper in 230V a-c position)

INPUT CURRENT: (maximum load at 50°C with nominal output voltage):

INPUT SOURCE	NOMINAL INPUT VOLT-AGE	MINIMUM INPUT VOLTAGE
120 V a-c input selection	1.8A typ. - 2.5A max.	2.3A typ. - 2.9A max.
220-240V a-c input selec-tion	0.9A typ. - 1.3A max.	1.2A typ. - 1.6A max.
d-c input selection	0.7A max. (320V input)	1.0A max. (240V input)

INPUT PROTECTION AND SOFT START: A triac soft start circuit reduces start-up surge. Units are protected against shorts by an input fuse. Fuse value 5A.

INPUT SURGE: At 25°C from cold start:

NOTE: There are two input surges at turn-on:

INPUT SOURCE	FIRST SURGE (5ms max.)	SECOND SURGE (3ms max.)
120 V a-c input selection	17A max.	12A typ.
220-240V a-c input selec-tion	34A max.	10A typ.
320V d-c input selection	34A max.	10A typ.

EFFICIENCY: 75% typical (78% typical for model RAX 3.3-20K)

STABILIZATION:

CHARACTERISTIC	TYPICAL	MAXIMUM
Source Effect (min - max)	0.8%	1.5%
Load Effect, measured at sensing terminals (10% - 100% load change)	0.8%	1.5%
Temperature effect (0 to 71°C)	1.0%	2.0%
Combined effect (envelope)	2.0%	4.0%
Drift (8 hr. at 25°C)	0.1%	0.5%

TRANSIENT RECOVERY: A step load change from 50% to 100% of rated load in 50 microseconds or more, produces no more than 4% output voltage excursion. Recovery to 1% of the original voltage is less than 1 millisecond.

OUTPUT HOLDING TIME: Output is maintained for 20 milliseconds minimum upon input interruption (30 milliseconds typical) with nominal input voltage and output load at 50°C current rating.

OVERVOLTAGE PROTECTION: Fixed, factory set. See Table 1. The overvoltage circuit is reset by interrupting input for approximately 15 seconds.

OPERATING TEMPERATURE: 0 -71°C. See the derating graph, Figure 1.

STORAGE TEMPERATURE: -20°C to + 75°C.

HUMIDITY: 20% to 95% relative humidity, noncondensing

ISOLATION: (at 25°C ambient, 65% relative humidity):

Between input and output terminals, 3.75 KV a-c for 1 minute (with Y-capacitors removed).
 Between input and output or chassis, 2000V a-c for 1 minute.
 Between output terminals and chassis, 500V a-c for 1 minute.

INSULATION RESISTANCE: Between output and chassis, 100 megohms minimum (500V d-c)

LEAKAGE CURRENT:

0.5mA max at 120V a-c (U.L. Method)
 0.75mA max at 240V d-c (U.L./VDE Method)

VIBRATION: Three Axes:

5-10 Hz., 10 mm amplitude
 10-55 Hz., 2g

SHOCK: Three axes, 20g, 11 ms ±5msec pulse duration

KEPCO, INC. ● 131-38 SANFORD AVENUE ● FLUSHING, NY. 11352 U.S.A. ● TEL (718) 461-7000 ● FAX (718) 767-1102
<http://www.kepcopower.com> ● email: hq@kepcopower.com

228-1226 REV 3

EMI CONDUCTED: FCC Class A

SAFETY: All units designed to meet UL 1950D3, UL 478, CSA Electrical Bulletin 1402C, VDE 0806, TÜV Rheinland EN60950 and IEC 950 Safety Standards. RAX are CE marked per the Low Voltage Directive (LVD), EN60950. [The standards do not apply with DC input operation].

REMOTE ERROR SENSING: RAX 3.3-20K and 5-20K models, up to 0.25V per load wire. All other models, up to 0.4V per load wire. The power supply is factory set with links in place.

REMOTE CONTROL ON/OFF:

“High,” 2.4V-24V (or open), unit ON

“Low,” 0.0V-0.4V (or closed), unit OFF

When Remote Control (RC) is at “Low” level, the output voltage remains $V_o < 0.5V$

$V_o < 5%$ of nominal output for 12, 15, 24, 28, and 48 volt models

III — OPERATION

UNIT WILL NOT WORK WITH SENSE LEADS DISCONNECTED (SEE FIG. 2).

INSTALLING THE POWER SUPPLY: Refer to Figure 4. The unit may be mounted on one of the three mounting surfaces. Mounting holes are provided for each mounting style. The air surrounding the power supply must not exceed the ambient values given in the graph in Figure 1.

CONNECTING AND SWITCHING THE LOAD: The load is connected as shown in links must therefore be removed from the sense terminals.

SELECTING INPUT VOLTAGE: Input voltage is selected with a jumper. Refer to Figure 3. The power supply is delivered for 120V a-c operation. Change the jumper to the position marked “230V” to operate the unit from a nominal 220-240V a-c or 320V d-c source.

CHANGING FUSES: Remove the cover to replace a fuse. The fuse holder will accept two sizes, either:

KEPCO P/N: 541-0072 or Manufacturer SAN-O P/N SS2-5A (1/4” x 1-1/4”)

KEPCO P/N: 541-0102 or Manufacturer SAN-O P/N Type EQ-5A (5mm x 20mm)

An additional thermal fuse protects the turn-on resistor R1. Refer to Figure 3. Replace this fuse with UCHIHASHI P/N U21 or KEPCO P/N 541-0086.

VOLTAGE ADJUSTMENT: The unit is provided with a voltage adjustment control. To adjust voltage, first place the unit under an operating load, then monitor the + and - sense terminals with a precision voltmeter and turn the voltage control to the desired operating value. Refer to Table 1 for Adjustment Range.

REMOTE TURN-ON TURN-OFF When power is on at the source the unit may be turned on or off with the remote control feature. The output of the remote turn-on/off RC (remote control) terminals operates at TTL logic levels (2.4V-24V “high” and 0.0 to 0.4V “low”). The unit is turned off by bringing the RC terminals to “low” logic level with a switch or solid state device. If the remote on/off feature is not desired, the terminals should be left open.

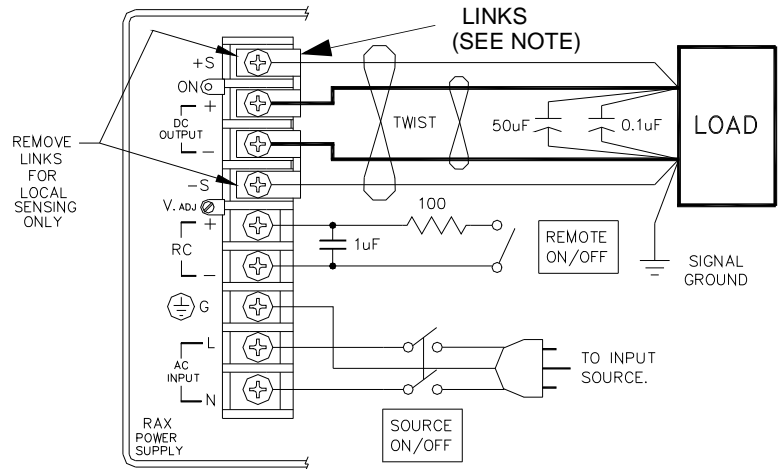
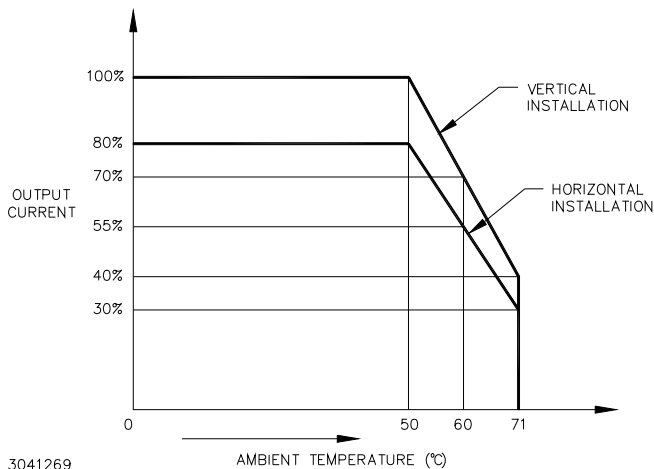

NOTE: THE SENSE LEADS MUST NEVER BE DISCONNECTED FROM THE OUTPUT. IF THE SENSE LEADS ARE ALLOWED TO FLOAT FREE OF THE OUTPUT, THE OUTPUT VOLTAGE WILL RISE TO THE OVERVOLTAGE POINT AND THE UNIT WILL SHUT DOWN.

- FOR REMOTE SENSING CONNECT THE SENSE TERMINALS TO THE LOAD AS SHOWN, AND REMOVE THE TWO SENSING LINKS.
- FOR LOCAL SENSING LEAVE THE SENSING LINKS IN PLACE AND CONNECT THE LOAD DIRECTLY TO THE BUS BAR.

FIGURE 1. TEMPERATURE DERATING

FIGURE 2. CONNECTING THE LOAD WITH ERROR SENSING

FIGURE 3. SIMPLIFIED VIEW, COVER REMOVED

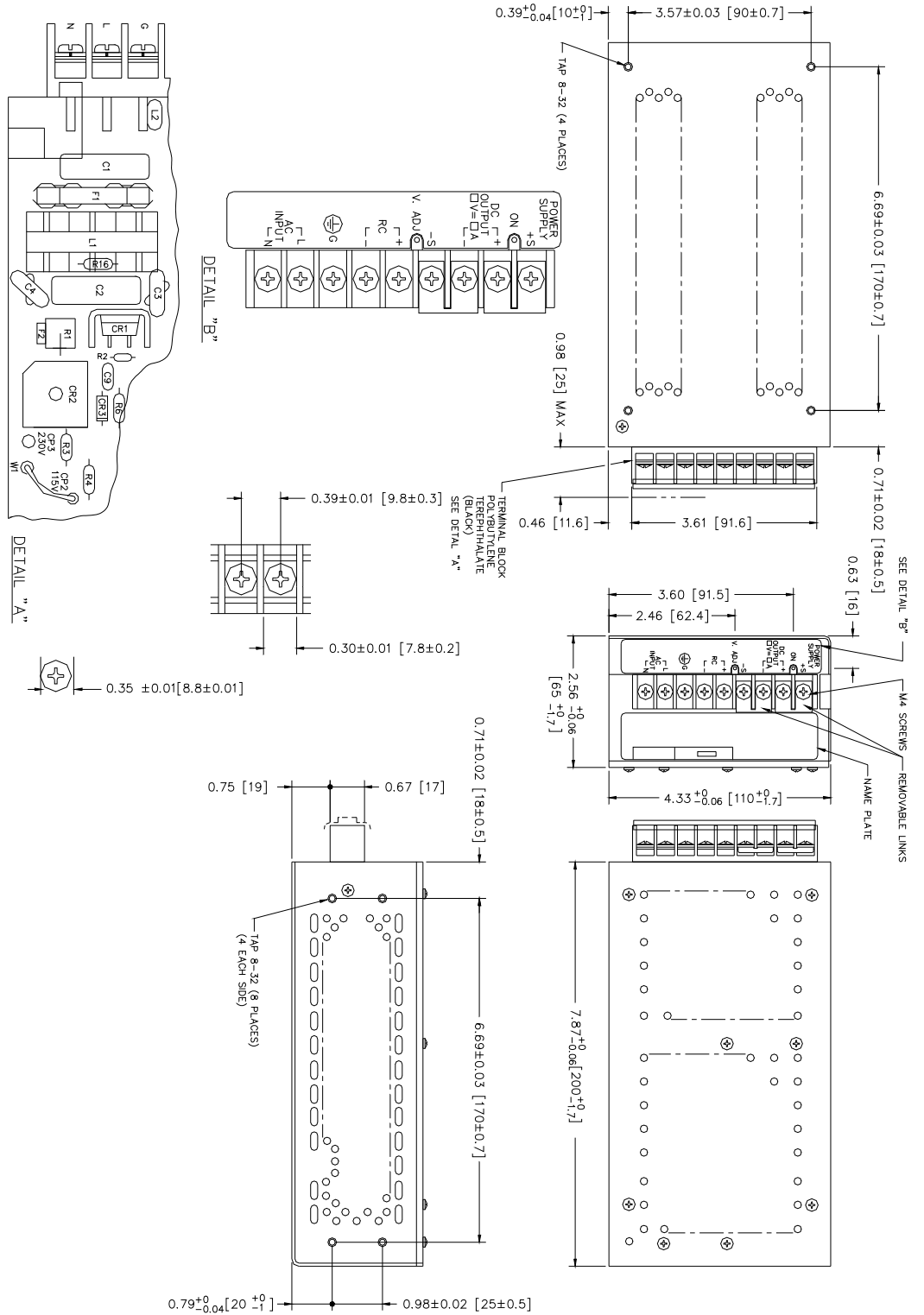

FIGURE 4. OUTLINE DRAWING, RAX 100W SERIES