

Features:

- Universal AC input / Full range
- Built in active PFC function, PF > 0.90
- +5V / 0.3A auxiliary output
- 150% Peak load Capability
- Constant current limit
- Power OK signal
- Remote ON / OFF, Remote sense function
- Protection: OVP, OLP, OTP, SCP, Fan failure
- 3 years warranty



MODEL		AK-350-05	AK-350-12	AK-350-15	AK-350-24	AK-350-48
Output	DC Voltage Range	5V	12V	15V	24V	48V
	Rated Current	60A	30A	24A	15A	7.5A
	Current Range	0 ~ 60A	0 ~ 30A	0 ~ 24A	0 ~ 15A	0 ~ 7.5A
	Rated Power	300W	360W	360W	360W	360W
	Ripple & Noise (Max.)	Note.2 150mVp-p	150mVp-p	150mVp-p	150mVp-p	150mVp-p
	Voltage Adj. Range	±10% Typical adjustment by potentiometer				
	Voltage Tolerance	Note.3 ±1.0%				
	Line Regulation	±0.5%				
	Load Regulation	±0.5%				
	Setup, Rise Time	800ms, 60ms at full load				
Hold Up Time (Typ.)	16ms / 230VAC at full load					
Input	Voltage Range	Note.4 90 ~ 264VAC, 127 ~ 370VDC				
	Frequency Range	47 ~ 63Hz				
	Power Factor (Typ.)	0.98 / 230VAC, 0.99 / 115VAC at full load				
	Efficiency (Typ.)	83%	90%	90%	91%	93%
	AC Current (Typ.)	4.0A / 115VAC, 2.0A / 230VAC				
	Inrush Current (Typ.)	27A / 115VAC, 54A / 230VAC				
Leakage Current	< 1.0mA / 240VAC					
Protection	Over Load	Hiccup mode: when the rated output power is within 105 ~ 150% for more than 3secs. Constant current limit: > 150% rated power / short circuit Auto-recovery: If O/P drop to 40% of the rated output voltage, PSU will shut down and auto-recover 5times (If fault condition remains after 5times recovery, PSU will shut down. User must re-power on to recover)				
	Over Voltage	6.0 ~ 6.5V	14.4 ~ 15.6V	18 ~ 19.5V	28.8 ~ 31.2V	57.6 ~ 62.4V
	Over Temperature	By detecting primary and secondary heat sink. Protection type: Shut down o/p voltage (Auto recovers automatically after temperature goes down)				
Function	Auxiliary Power	5V / 0.3A (±3%)				
	Remote ON / OFF Control	External switch or NPN Transistor to turn ON / OFF				
	Power OK Signal	Open drain signal low when PSU turns on, Max. sink current: 20mA, Max. drain voltage: 40V.				
Environment	Working Temp.	-20 ~ +70°C (Refer to output load de-rating curve)				
	Working Humidity	20 ~ 90% RH non-condensing				
	Storage Temp. & Humidity	-40 ~ +85°C, 10 ~ 95% RH				
	Temp. Coefficient	±0.02% / °C (0 ~ 50°C)				
	Vibration	10 ~ 500Hz, 5G 10min. / 1cycle, period for 60min. each along X, Y, Z axes Compliance to IEC 68-2-6, IEC 68-2-64				
Safety & EMC	Safety Standards	Certified UL 60950-1; EN 60950-1				
	Withstand Voltage	Note.6 I/P-O/P: 3KVAC (4242VDC), I/P-FG: 1.5KVAC (2121VDC), O/P-FG: 0.5KVAC (707VDC), 1min				
	Isolation Resistance	I/P-O/P, I/P-FG, O/P-FG: 100M Ohms / 500VDC				
	EMI Conduction & Radiation	Certified EN 55022				
	Harmonic Current	Certified EN 61000-3-2; EN 61000-3-3				
EMS Immunity	Certified EN 55024; IEC 61000-4-2, 3, 4, 5, 6, 8, 11					
Others	MTBF	74,56K HRS Certified MIL-HDBK-217F				
	Cooling	Load and temperature control fan				
	Dimension (WxHxD)	105x41x199 mm / 4.134x1.614x7.835 inch				
	Packing	1.1kg; 18pcs / 20.1kg / 1.02CUFT				
Note	<p>1. All parameters NOT specially mentioned are measured at 230VAC input, rated load and 25°C of ambient temperature.</p> <p>2. Ripple & noise are measured at 20MHz of bandwidth by using a 12" twisted pair-wire terminated with a 0.1uF & 47uF parallel capacitor.</p> <p>3. Tolerance: includes set up tolerance, line regulation and load regulation.</p> <p>4. De-rating may apply in low input voltage. Please check the de-rating curve for more details.</p> <p>5. The power supply is considered a component which will be installed into a final equipment. The final equipment must be re-confirmed that it still meets EMC directives.</p> <p>6. Conduct this test without enclosure.</p>					

Mechanical Specification:

Unit:mm[inch]

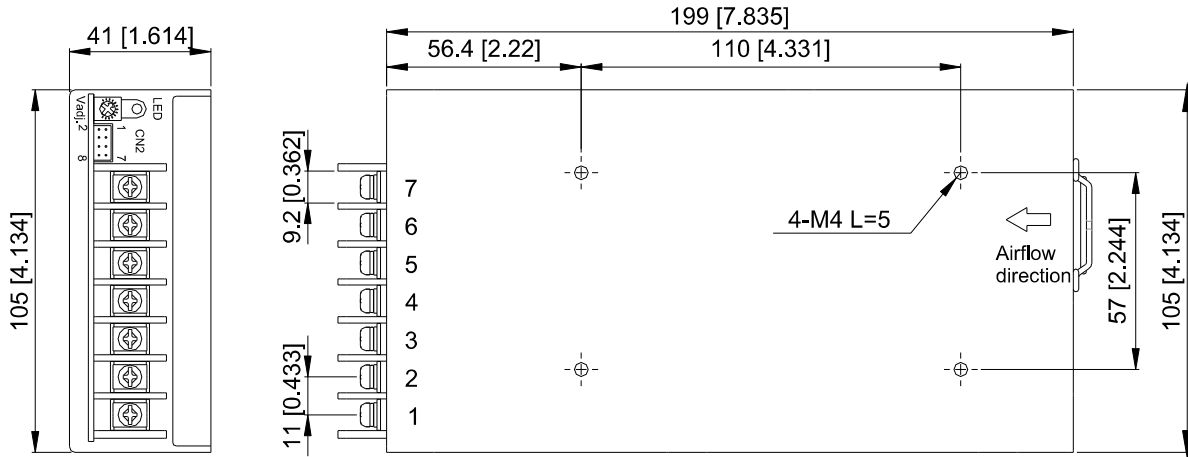

AC Input & DC Output Pin No. Assignment

Pin No.	Assignment
1	AC/L
2	AC/N
3	FG
4,5	-V
6,7	+V

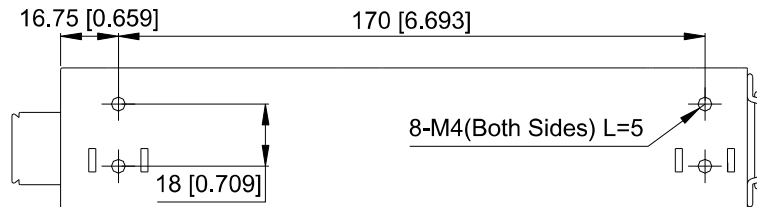

Control pin number assignment (CN2) : JST S8B-PHDSS or equivalent

Pin No.	Assignment	Pin No.	Assignment	Mating Housing	Terminal
1	AUX	5	GND	PHDR-08VS	SPHD-002T-P05
2	GND	6	EN+		
3	P-OK	7	VS+		
4	EN-	8	VS-		

Function Description of CN2:

Pin No.	Function	Description
1	AUX	+5V / 0.3A auxiliary power
2	GND	Ground
3	P.OK	Power OK
4	EN-	Remote ON/OFF (-)
5	GND	Ground
6	EN+	Remote ON/OFF (+)
7	VS+	Remote voltage sense (+)
8	VS-	Remote voltage sense (-)

■ **De-rating Curve:**

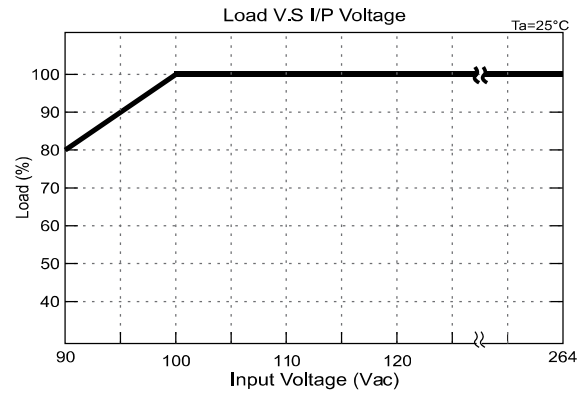
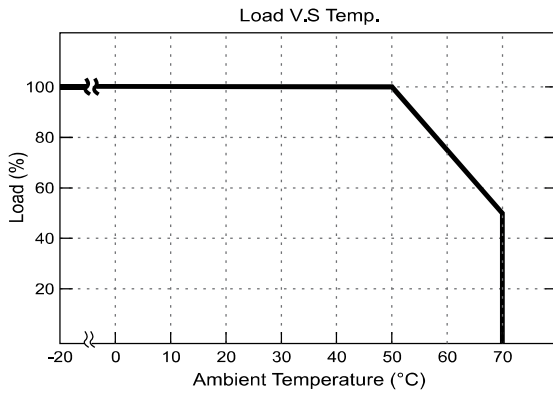

■ **Peak Loading:**

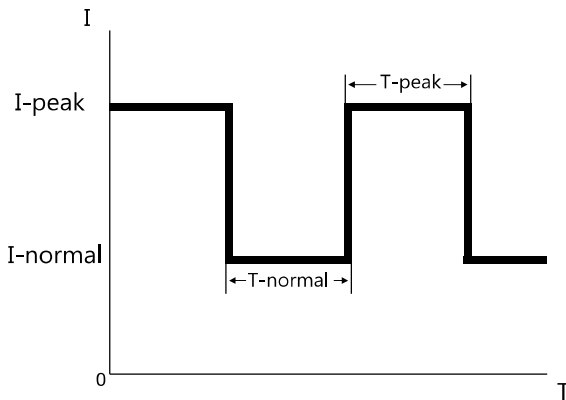

T-PEAK represents the period during which the output current is at 110% to 150% of nominal (shown as I-PEAK). Curve B shows the relationship between the percentage of peak current (I-PEAK) and the allowable duration (T-PEAK). If the peak current is taken for longer than the allowed duration indicated by curve B, the output current will drop to a constant limited current of 105% of nominal, then. The unit between peak currents (T-NORMAL) is dependant up on the output current drawn between the peaks (I-NORMAL) and curve A shows the relationship between the two. The higher the percentage of normal current (I-NORMAL) is of the nominal current, the longer the interval (T-NORMAL) before the next peak current can be drawn.

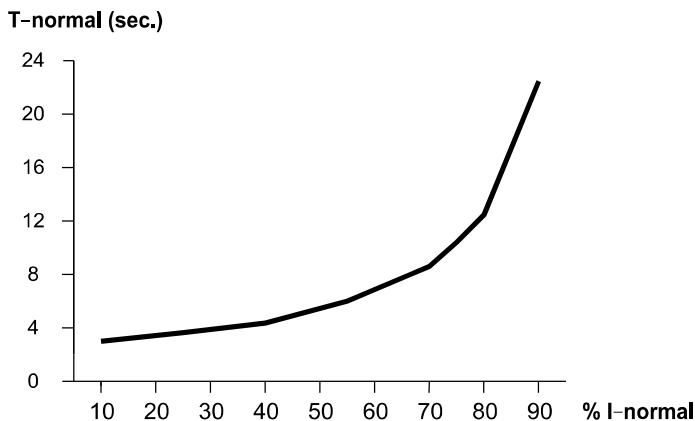

CURVE A

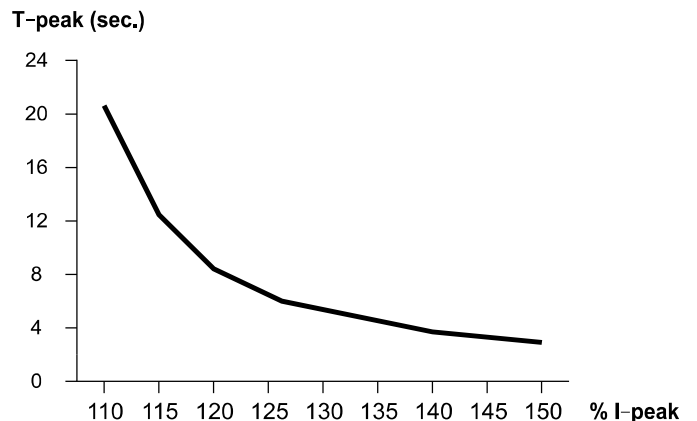

CURVE B

1. Power OK Signal and Auxiliary output

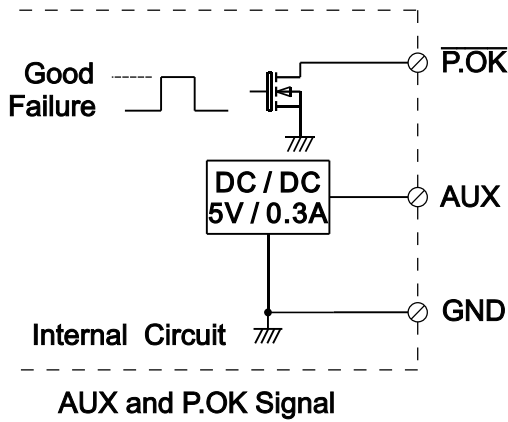

*Place an additional capacitor to have a better performance of auxiliary power operation.

*The grounding of "AUX" power should be connected to "GND" port. If "V-" is connected as Grounding, make sure to short the GND and V- ports.

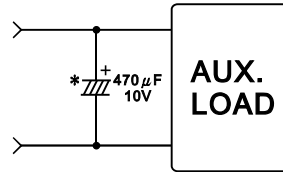

2. Remote ON/OFF Control

(A)

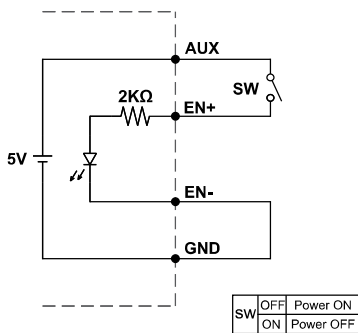

(A) Using internal 5V auxiliary source

(B)

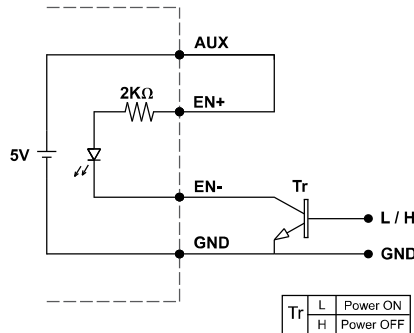

(B) ON / OFF Control by NPN transistor

(C)

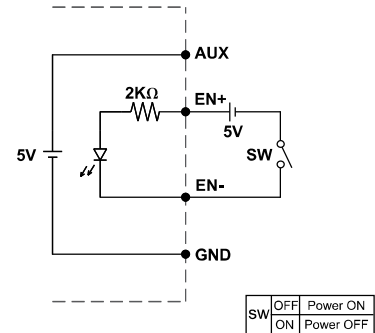

(C) Using external voltage source

3. Remote Sense

