

Features :

- Built-in active PFC function, PF>0.95
- High efficiency 92% and low power dissipation
- Protections: SCP / OLP / OVP / OTP
- Cooling by free air convection
- Two peak load mode select by user.
- Can be installed on DIN rail TS-35 / 7.5 or 15
- Built-in DC OK Relay contact
- Built-in Remote ON / OFF function
- 100% full load burn-in test
- 150% peak load capability
- 3 years warranty



MODEL		DV-240-24	DV-240-48
OUTPUT	DC Voltage Range	24V	48V
	Rated Current	10A	5A
	Current Range	0 ~ 10A	0 ~ 5A
	Rated Power	240W	240W
	Peak Current	15A	7.5A
	Peak Power Note.6	360W (3sec.) Two peak load mode select by user.	
	Ripple & Noise (max.) Note.2	150 mVp-p	300 mVp-p
	Voltage Adjustment Range	-2% ~ +8%	-2% ~ +8%
	Voltage Tolerance Note.3	±1.0%	±1.0%
	Line Regulation	±0.5%	±0.5%
	Load Regulation	±1.0%	±1.0%
	Setup, Rise Time	700ms, 30ms/230VAC /115VAC at full load	
Hold Time (Typ.)	20ms / 230VAC 20ms / 115VAC at full load		
INPUT	Voltage Range	88V ~ 264VAC 124 ~ 373VDC	
	Frequency Range	47 ~ 63Hz	
	Power Factor(Typ.)	0.96 / 230VAC / 115VAC at full load	
	Efficiency (Typ.)	91%	92%
	AC Current (Typ.)	2.6A / 115VAC	1.3A / 230VAC
	Inrush Current (Typ.)	33A / 115VAC	65A / 230VAC
Leakage Current	< 1mA / 240VAC		
Protection	Over Load	> 150% rated power or short circuit is constant current limiting, if o/p drop to 40% rating output voltage then shutdown and auto-recover 5 time, if fault condition not remove in this 5 time, the system well be shutdown and re-power on to recover.	
	Over Voltage	28 ~ 33V	56 ~ 65V
	Over Temperature	95±5° C (TSW : detect on heatsink of power diode) Protection type : Shut down o/p voltage, recovers automatically after temperature goes down	
Protection	DC OK REALY CONTACT RATINGS (max.)	60Vdc/0.3A, 30Vdc/1A, 30Vac/0.5A resistive load	
Environment	Working Temp. Note.5	-25 ~ +70°C (Refer to output load de-rating curve)	
	Working Humidity	20 ~ 95% RH non-condensing	
	Storage Temp., Humidity	-40 ~ +85°C 10 ~ 95% R.H	
	Temp.Coefficient	±0.03%/°C (0 ~ 50°C)	
	Vibration	Component : 10 ~ 500Hz, 2G 10min/1cycle, 60 min each along X,Y,Z axes; Mounting: Compliance to IEC60068-2-6	
Safety & EMC Note.4	Safety Standards	UL508 / TUV EN60950-1	
	Withstand Voltage	I/P - O/P: 4242VDC I/P - FG: 2121VDC O/P-FG : 707VDC O/P-DC OK: 707VDC	
	Isolation Resistance	I/P-O/P, I/P-FG, O/P-FG:>100M Ohms / 500VDC / 25°C / 70% RH	
	EMI Conduction & Radiation	EN55022: 2006 Class B	
	Harmonic Current	EN61000-3-2: 2006 Class A, EN61000-3-3: 1995+A1: 2001+A2: 2005	
	EMS Immunity	EN61204-3: 2000, EN55024: 1998+A1: 2001+A2: 2003 light industry level, criteria A	
Others	MTBF	xxxK HRS Compliance: MIL-HDBK-217F(25°C)	
	Dimension (LxWxH)(mm)	65.8x125x117.7	
	Packing	0.9kg;12Pcs/12.8kg	
Note	<p>1. All parameters NOT specially mentioned are measured at 230VAC input, rated load and 25 of ambient temperature.</p> <p>2. Ripple & noise are measured at 20MHz of bandwidth by using a 12" twisted pair-wire terminated with a 0.1uf & 47uf parallel capacitor.</p> <p>3. Tolerance : includes set up tolerance, line regulation and load regulation.</p> <p>4. The power supply is considered a component which will be installed into a final equipment. The final equipment must be re-confirmed that it still meets EMC directives.</p> <p>5. Installation clearances : 40mm on top, 20mm on the bottom, 5mm on the left and right side are recommended when loaded permanently with full power. In case the adjacent device is a heat source, 15mm clearance is recommended.</p> <p>6. 3 seconds or 20% duty cycle max, and the average output power should not exceed the rate power.</p> <p>7. Derating may be needed under low input voltage. Please check the derating curve for more details.</p>		

Mechanical Specification

Unit : mm

Terminal Pin No. Assignment (TB1)

Pin NO.	Assignment
1	FG ⊕
2	AC/L
3	AC/N

Terminal Pin No. Assignment (TB2)

Pin NO.	Assignment
1	DC+
2	DC-
3	INH+
4	INH-
5,6	Relay Contact

Switch No. Assignment

SW NO.	Assignment
SW1	PEAK LOAD SETTING
SW2	REMOTE ON/OFF SETTING

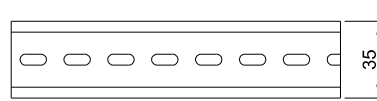
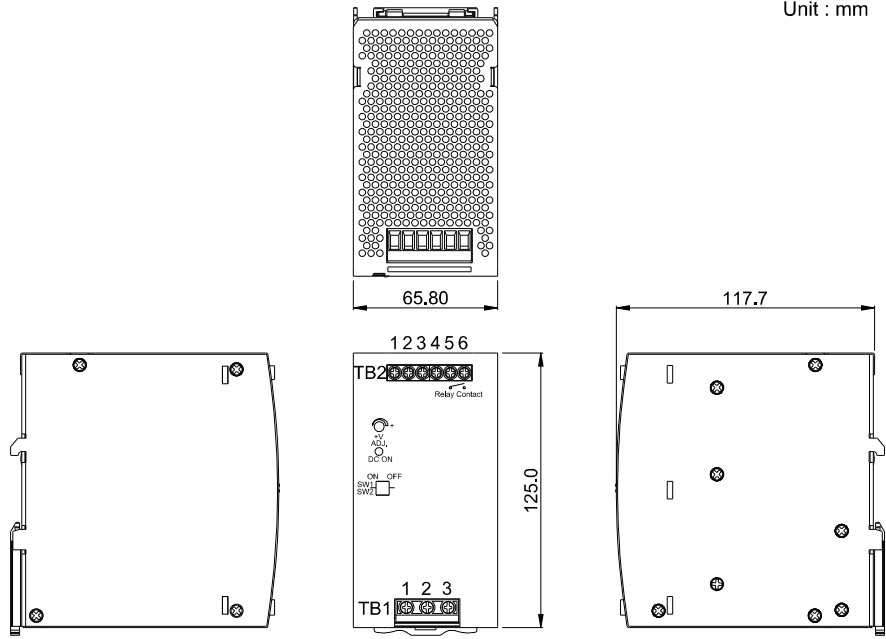

Admissible DIN-RAIL:
TS35/7.5 OR TS35/15

Block Diagram

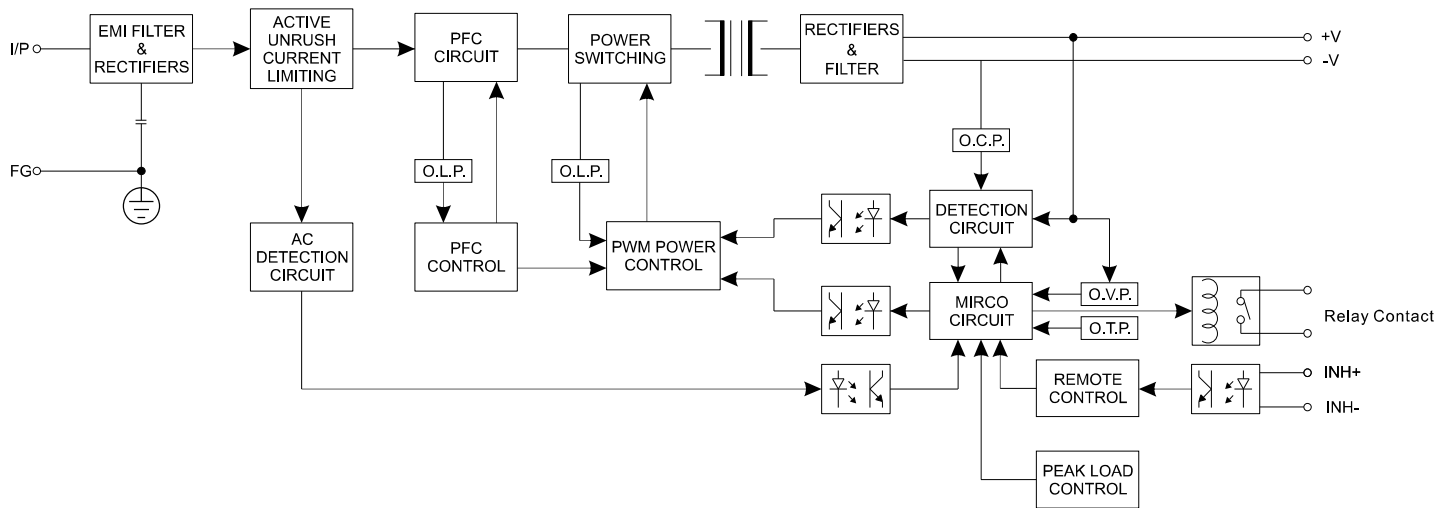

DC OK Relay Contact

Contact Close	When the output voltage reaches the adjusted output voltage.
Contact Open	When the output voltage drop below 45% output voltage.
Contact Ratings(max.)	30V/1A resistive load

■ Peak Loading SW1 ON (Mode1) Default setting

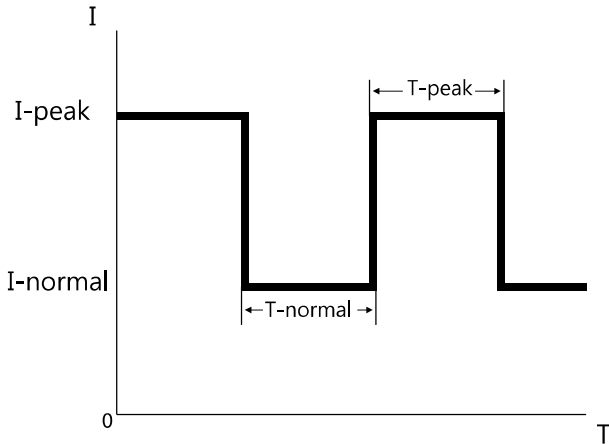

T-peak presents while the unit is working within 110%~150% Rating output power. See curve " B " for the variation in T-peak btw output current and holdup time.
 If T-peak is more than the time setting in curve "B", the output current will drop to the constant current limited (I-normal) that is 105% rating power, meanwhile, I- normal and T-normal will be presenting. See curve "A" for the timing back to I-Peak of T-normal and this Mode can use for easy 2-stage battery charger.

■ Peak Loading SW1 OFF (Mode2)

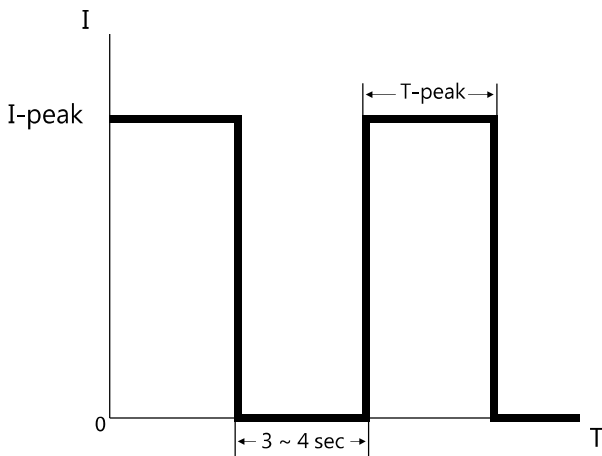

T-peak presents while the unit is working within 110%~150% Rating output power. See curve " B " for the variation in T-peak btw output current and holdup time.
 If T-peak is more than the time setting in curve "B", the output voltage will be shut down for 3~4 sec, then auto-recovery.

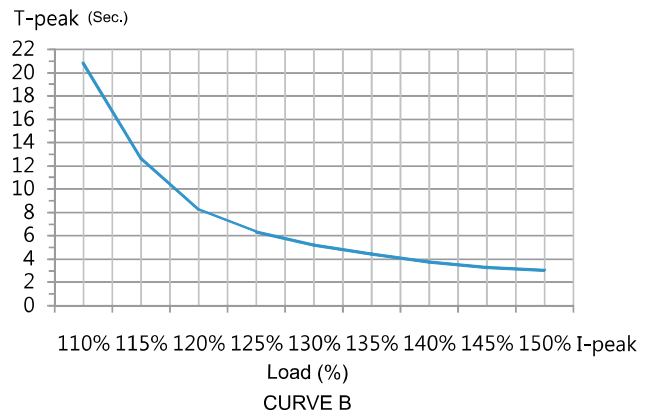
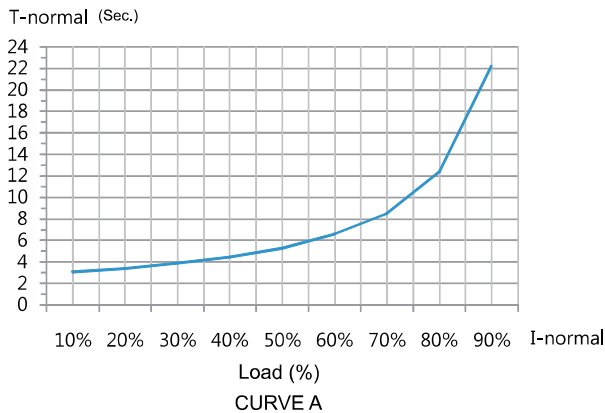

Remote ON / OFF

The PSU can be turned ON/OFF by using the "Remote Control" function.

SW2	INH+(3 PIN)/ INH-(4 PIN)	Output Status
OFF	SW ON (>2.5V)	ENABLE
OFF	SW OFF (<0.8V)	DISABLE
ON	SW ON (>2.5V)	DISABLE
ON	SW OFF (<0.8V)	ENABLE

(Default Setting)

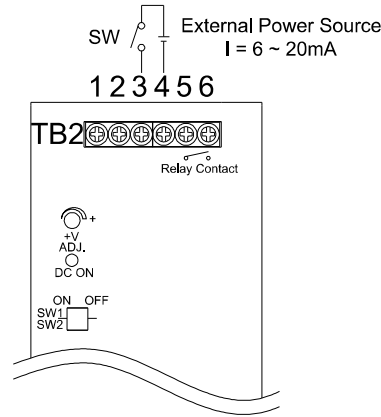

De-rating Curve

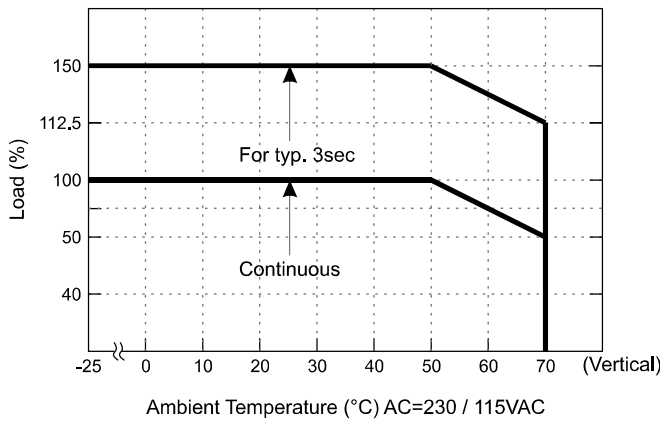

Output derating VS input voltage

