

# INSTRUCTION MANUAL



**KEPCO** An ISO 9001 Company.

**KIT  
219-0442**

## CHASSIS SLIDES KIT NO. 219-0442

### 1. DESCRIPTION

This Kepco KIT contains the components required to install chassis slides on Kepco RA 58 or RA 60 Rack Adapters to accommodate 22- to 26-inch deep cabinets.

### 2. INSTALLATION OF CHASSIS SLIDES

#### 2.1 MATERIAL REQUIRED (SEE TABLE 1.)

**TABLE 1. MATERIAL REQUIRED**

MATERIAL	LOCATION	QUANTITY
Slide (includes cabinet and chassis sections), Kepco P/N 108-0318 (Jonathan P/N 110QD-18-1)	Provided in this Kit	2
End Bracket, Kepco P/N 128-1849 (Jonathan P/N SPO-440-Z)	Provided in this Kit	2
End Bracket, Extended, Kepco P/N 128-1699 (Jonathan P/N 204161 RETMA)	Provided in this kit	2
Screw 10-32 x 3/8 in. long, BHPH, cadmium/yellow plated Kepco P/N 101-0311	Provided in this Kit	16
Nut, 10-32 Kepco P/N 102-0008	Provided in this Kit	8
Washer, flat #10 Kepco P/N 103-0031	Provided in this Kit	8
Washer, Internal lock, #10, Kepco P/N 103-0019	Provided in this Kit	8

#### 2.2 PROCEDURE (SEE FIGURES 1, 2 AND 3.)

1. Attach two chassis sections of slide (108-0318) to each side of rack adapter using eight screws (101-0311) (see Figure 1).

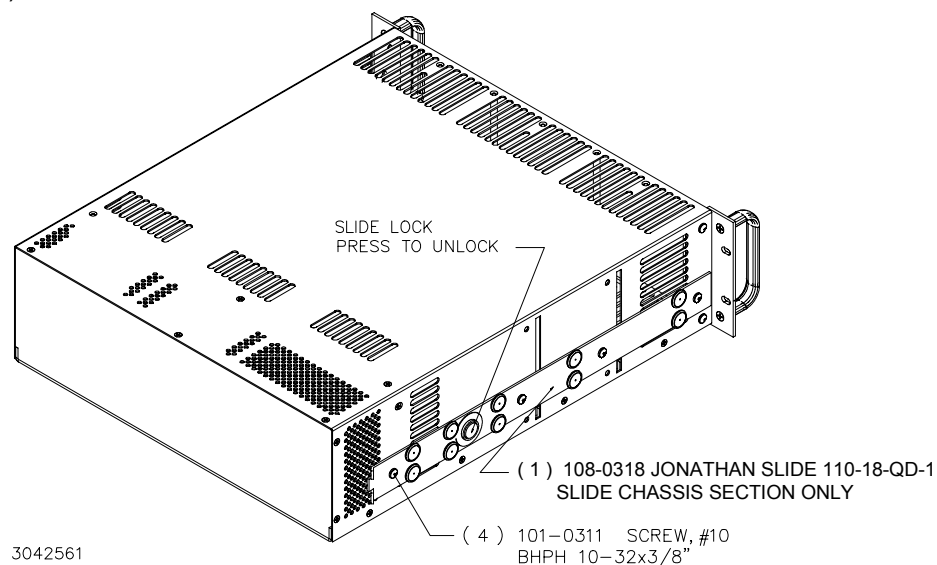

**FIGURE 1. INSTALLING CHASSIS SLIDES ON RACK ADAPTER**

KEPCO, INC. ● 131-38 SANFORD AVENUE ● FLUSHING, NY. 11352 U.S.A. ● TEL (718) 461-7000 ● FAX (718) 767-1102  
<http://www.kepcopower.com> ● email: [hq@kepcopower.com](mailto:hq@kepcopower.com)

- Attach two end brackets (128-1849) and two extended end brackets (108-1699) to the two cabinet sections of slides (108-0318) using eight screws (101-0311), flat washers (103-0031), lockwashers (103-0019), and nuts (102-0008) (see Figure 2).

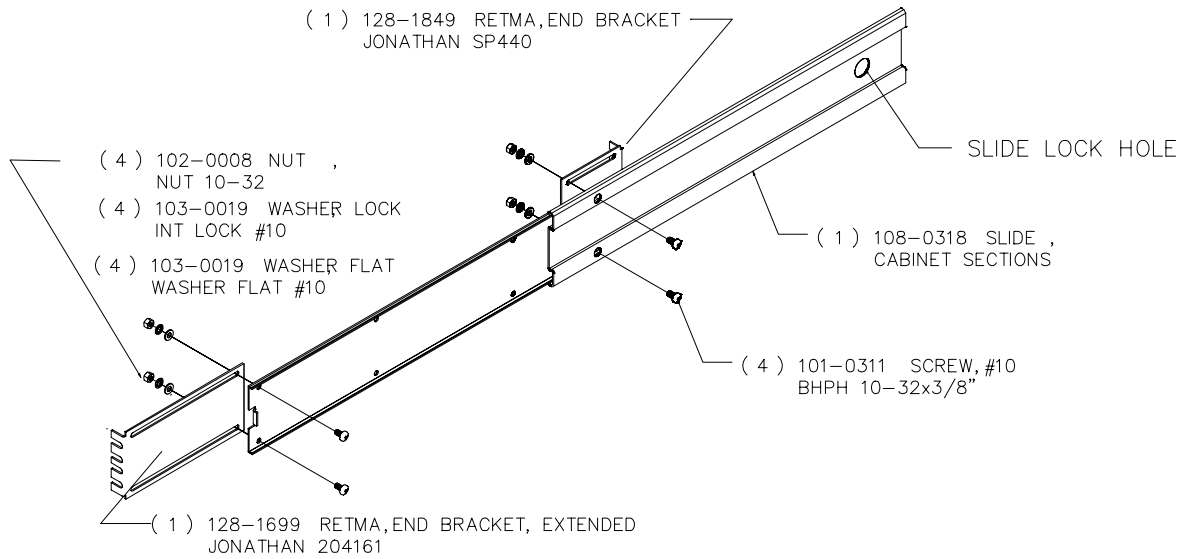

3042624

**FIGURE 2. ATTACHING END BRACKETS TO SLIDE (CABINET SECTION)**

- Attach mounting brackets (with cabinet section of slide attached) to the cabinet rail (attaching hardware not supplied) (see Figure 3).

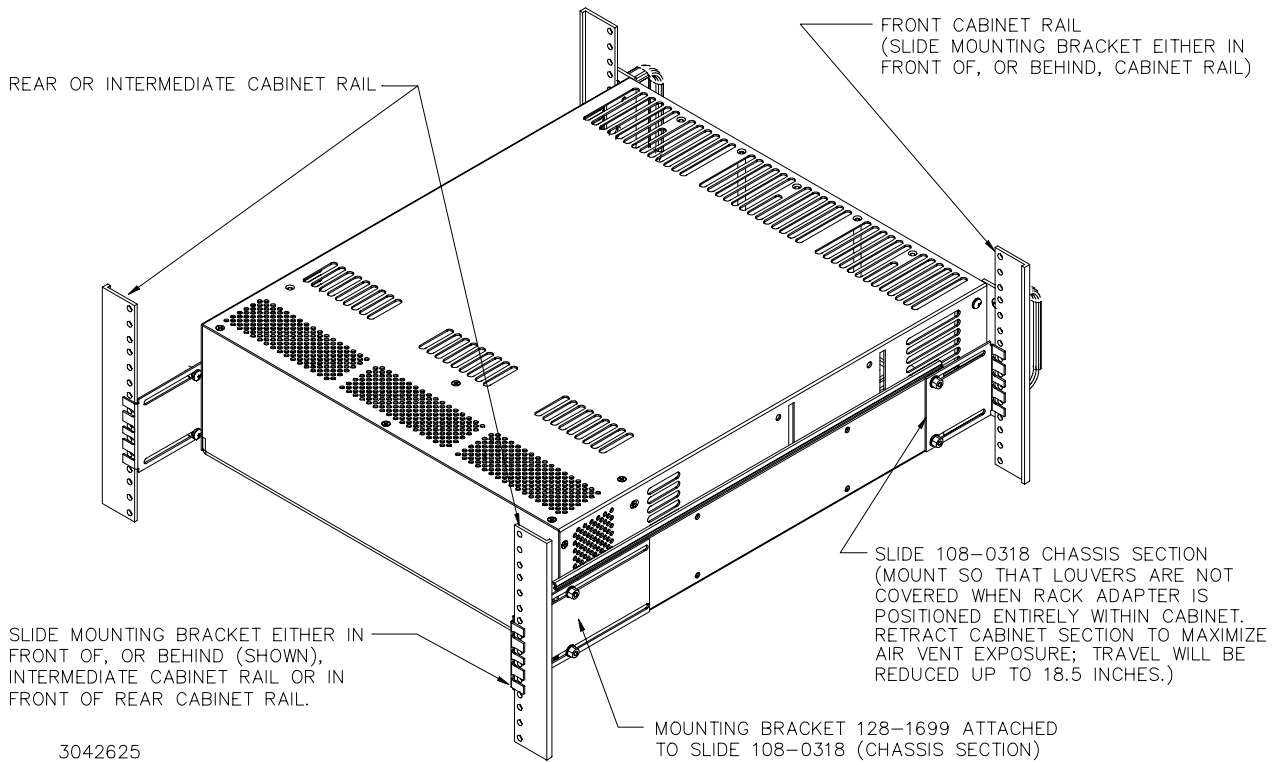

3042625

**FIGURE 3. ATTACHING CABINET SECTION TO RAIL**

- Insert rack adapter into rack (insert chassis-mounted slide section into the cabinet mounted slide section).