

# INSTRUCTION MANUAL

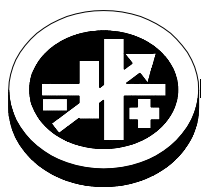

**KEPCO** An ISO 9001 Company.

**HSF-PFC**  
**100W SERIES**



## KEPCO SINGLE OUTPUT 100 WATT HOT SWAP PLUG-IN POWER SUPPLIES

### I — INTRODUCTION

The Kepco HSF-PFC 100 Watt series hot swappable, high frequency switching, plug-in power supplies with built in power factor correction employ forward conversion and are designed to operate in a fault tolerant power system with either a-c or d-c input. A negative temperature coefficient (NTC) thermistor limits start-up surge. A built-in forced current share circuit and OR-ing diodes allow configuration for hot-swap and parallel-redundant N+1 operation.

These power supplies are designed to be installed in Kepco's RA 19-(X)B Rack Adapters (Figure 2). RA 19-6B accepts up to six 150W units, RA 19-7B accepts up to three 150W units, and up to four 50W or 100W units and RA 19-8B accepts up to eight 50W or 100W units. The applicable RA 19-(X)B Operator Manual can be downloaded from the Kepco web site at:

[www.kepcopower.com/support/opman1s.htm#ra19-xb](http://www.kepcopower.com/support/opman1s.htm#ra19-xb)

All input/output connections are through a 24 pin connector that plugs in to the rack adapter. All external connections are made through the rack adapter.

### II — FEATURES

**FRONT PANEL ACCESS.** The front panel provides a power ON/OFF switch controlling input power and a "VDC ON" light which indicates when the unit is operating. **NOTE: The ON/OFF switch must be set to OFF before removing unit from (or inserting into) rack adapter.**

The front panel "MASTER ON" LED lights when 1) the unit operates independently, or 2) the unit is used in parallel redundant configurations while a) the output current is within 10% to 100% of nominal and the unit is functioning as a master or b) the output current is less than 10% of nominal. In parallel redundant configurations, the module with the highest voltage functions as the master. The other units are slaves, and track the output voltage of the master. Refer to **Current Share Bus (CSB)** on page 3 for details. (The MASTER ON LED is not used on 3.3V model; it is always off.)

Seven models may be selected for outputs of 3.3, 5, 12, 15, 24, 28, or 48V (see Table 1 or 2).

When the input is cut off, the output is maintained for 20 milliseconds minimum. If the power supply shuts down due to an output overvoltage condition, it is then necessary to turn the unit off and wait approximately 30 seconds minimum before turning the unit on again.

Specifications for each model of the HSF-PFC 100 Watt Series are listed in Section III, on page 4 (standard models) and Section IV, on page 6 (suffix C, T, X and Y).

**OPTIONS.** Options are identified by suffix: T (-PFCT) offers improved efficiency and less weight; C (-PFCC) offers current monitoring via an integral current sensing resistor (includes option T); X (-PFCX) offers remote on/off (includes option T); and Y (-PFCY) includes options C, X and T.

The front panel Vadj trimmer provides adjustment of the output voltage within the limits specified in Table 1 or 2; test points connected to the +S and -S lines are available at the front panel for measuring the output voltage.

**FORCED CURRENT SHARE CIRCUIT.** (Not available on 3.3V model.) When units are configured for N+1 parallel redundant operation, it is desirable for current to be divided equally among the paralleled supplies. When the CSB (Current Share Bus) lines of paralleled units are connected together, the load current is forced to divide equally between all paralleled units. If one unit fails, the remaining units continue to supply the load, and the load current is divided equally among the remaining operating units. The failed unit is automatically isolated from the circuit by a built-in isolation diode. Refer to **Current Share Bus (CSB)** on page 3 for details.

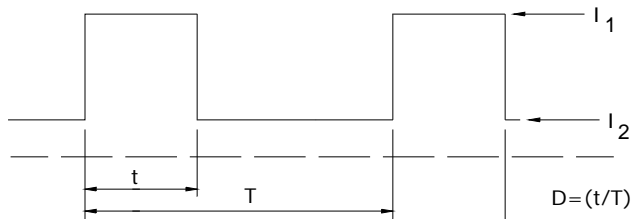

3043527

The standard 24V Model (no options) can supply Peak current listed in Table 1 if the four conditions listed below are met. These models include thermal protection, voltage shutdown type. Restart by removing a-c input; after sufficient cooling, reapply a-c input (wait at least 30 seconds).

1. Time:  $t \leq 10$  Seconds

2.  $I_1 \leq$  Peak Current (Amperes)

3. Effective Current:

$$\sqrt{DI_1^2 + (1-D) \times I_2^2} \leq \text{Rated current (Amperes)}$$

4. Effective Power  $P \leq$  Maximum Power (Watts)  
(output RMS current x output voltage)

**CURRENT MONITOR.** Current monitor (C and Y models only) is via  $\pm$ IMON assigned to pins of the RA 19-(X)B I/O connector. Monitored Output Current (Amps) = Voltage drop across  $R_{EQ}$  (mVolts) /  $R_{EQ}$  (mOhms) where  $R_{EQ}$  is the sum of  $R_S$  (see Table 2) + trace resistance to point where current monitor is connected, approximately 4mOhms. The voltage drop across  $R_{EQ}$  is measured across  $\pm$  IMON pins (requires millivoltmeter, range 0 to 250mV). Accuracy is  $\pm 10\%$ ; contact Kepco if greater accuracy is required. There is no isolation between  $\pm$ IMON, alarm circuit and d-c output. Refer to the applicable RA 19-(X)B Manual for details.

**ALARM CIRCUIT.** Any condition which causes the unit to be out of specified voltage/current ranges (including overvoltage, overcurrent, overtemperature, open sense line, ac input line failure, etc.) results in an alarm. All models include an isolated internal relay offering normally closed and normally open contacts referenced to an isolated common. These contacts are rated for 1A at 30V d-c and 0.5A at 125V a-c. These contacts may be used to configure "close on failure" or "open on failure" alarm circuits (see Figure 3 for typical alarm circuits). Refer to the applicable RA 19-(X)B Manual for details about the following: 1) normally open (close on failure) contacts are not available if  $\pm$ RC is used on X and Y suffix models, 2) alarm signals are not isolated on C, X and Y models and 3) alarm configurations for multiple power supplies.

**KEYING.** Keying of the power supply is established at the factory. The output voltage determines which keyway is open. When the corresponding rack adapter key (pin) is installed by the user, only a power supply of the correct voltage can be inserted in the rack adapter slot.

**FIGURE 1. 24V MODEL PEAK CURRENT REQUIREMENTS (**

**REMOTE ON-OFF.** Remote on-off (X and Y models only) is via  $\pm$ RC assigned to pins of the RA 19-(X)B I/O connector: off = no voltage, short circuit, or 0 to 0.8V, on = 4.5 to 12.5V (or 12.5 to 24.5V via 1.5K Ohms). To reverse on-off polarity contact Kepco. There is no isolation between  $\pm$ RC, d-c output and alarm circuit. Refer to the applicable RA 19-(X)B Manual for details.

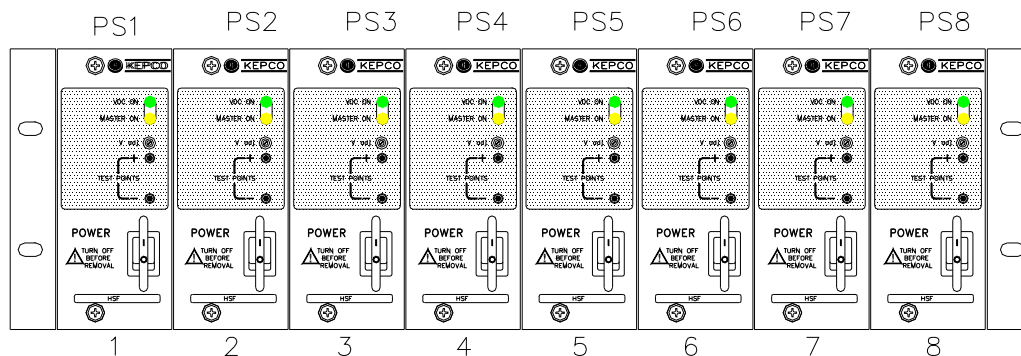

3041298

**FIGURE 2. HSF-PFC 100 WATT POWER SUPPLIES (8) INSTALLED IN RA 19-8B RACK ADAPTER**

CONNECTIONS: The 24-pin I/O connector is designed to mate with the corresponding connector in the Series RA 19-(X)B Rack Adapter. (See Rack Adapter manual for pin assignments.)

**(+) SENSE, (-) SENSE:** These lines are provided to compensate for voltage drops in the load connecting wires. The **Sense lines must be connected to their respective (+) and (-) output terminals**, either at the load or at the rack adapter (see Rack Adapter Manual). The connection ensures the most accurate error tracking. Maximum voltage drop compensation in the load connecting wires for each model is calculated as the difference between the minimum overvoltage (see Table 1 or 2) and the maximum adjustment range (see Table 1 or 2), divided by two to give the voltage drop compensation per lead. Higher compensation values are possible if output voltage is decreased below the maximum adjustment range shown in Table 1 or 2.

**NOTE:**

The Sense lines must be connected for the power supply to work properly!

**OUTPUT (+), OUTPUT (-):** These lines are the power supply d-c output lines which are connected to the load.

**CURRENT SHARE BUS (CSB):** (Not available on 3.3V model.) Connecting the CSB lines of power supplies operating in a parallel configuration causes output current to be shared equally. (See Rack Adapter Manual for additional information on parallel configurations.) For current sharing to work properly the outputs of all paralleled units must be within 250 mV (max) of each other and each unit must be operating at between 10% to 100% of rated output current. If current to the load goes below 10% for each unit in current share mode, all MASTER ON lights may go on (see load effect specifications); this indicates that forced current share is no longer working, units are simply in automatic current share mode. (If forced current sharing at less than 10% nominal current per supply is needed, contact Kepco application engineering.) Remote sensing is recommended. For master/slave operation to work properly each unit should be adjusted to 40 mV (optimum) less than the next paralleled unit. Unit 1 is adjusted to  $V_{OUT}$ , unit 2 to  $V_{OUT} - 40mV$ , and unit 3 to  $V_{OUT} - 80mV$ , etc. If the master fails, the unit 2 will become the new master. The 40 mV difference can be reduced to a minimum of 25 mV as needed

to parallel many units and still keep all units within 250 mV of each other. Adjust the outputs using  $V_{adj}$  trimmer on front panel.

- Optimum difference among output voltages of paralleled units: 40mV
- Maximum difference among output voltages of paralleled units: 250 mV
- Minimum difference among output voltages of paralleled units: 25 mV

**ALARM:** The Alarm NC (normally closed) - Open on Failure and Alarm NO (normally open) - Close on Failure lines are relay contacts referenced to Alarm Common. If the unit fails, the path between Alarm NC - Open on Failure and Alarm Common opens, the path between Alarm NO - Close on Fail and Alarm Common is a short circuit. Figure 3 illustrates typical Close on Fail and Open on Fail circuits to give a failure indication if any one of a number of power supplies fail. See RA 19-(X)B Manual for limitations applicable to C, X and Y suffix models described in "Alarm Circuit." on page 2.

**INPUT POWER:** Line (either a-c or d-c source power), Neutral and Ground (chassis)

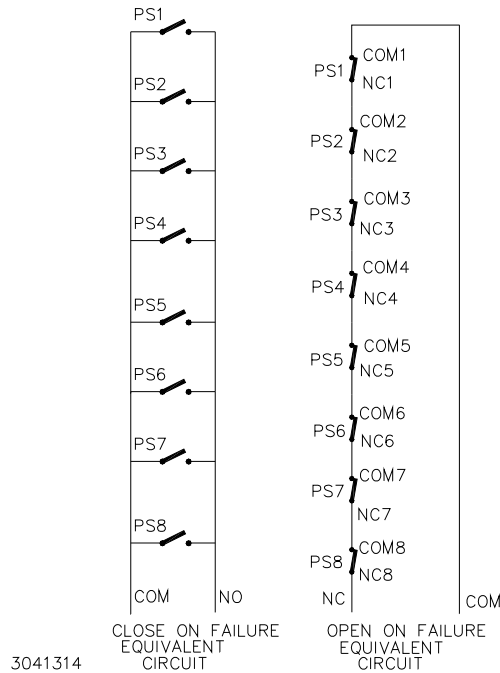

**FIGURE 3. TYPICAL ALARM CIRCUIT DIAGRAMS**

### III — SPECIFICATIONS (STANDARD)

The following specifications apply to all standard (no suffix) HSF-PFC 100 Watt Series models. Table 1 lists the specifications that differ for each model. Common specifications that apply to all standard models are listed in the paragraphs following Table 1. Other models are also avail-

able; consult your Kepco representative for their specifications.

**NOTE:** Common specifications apply to all models except where otherwise indicated.

**TABLE 1. OUTPUT RATINGS AND SPECIFICATIONS, HSF-PFC 100W SERIES (STANDARD: NO SUFFIX)**

MODEL	HSF 3.3-20PFC	HSF 5-20PFC	HSF 12-8.5PFC	HSF 15-7PFC	HSF 24-4.5PFC	HSF 28-3.8PFC	HSF 48-2.1PFC	
OUTPUT VOLTS, d-c (NOMINAL)	3.3V	5V	12V	15V	24V	28V	48V	
ADJUSTMENT RANGE	2.8 - 3.4V	4.3 - 5.3V	11.4 - 12.6V	13.5 - 16.5V	19.2 - 26.0V	26.5 - 29.5V	44.0 - 52.0	
OVERVOLTAGE SETTING (25°C, NOM. INPUT)	3.4 - 4.6V	5.2 - 6.5V	13.2 - 15.2V	16.5 - 18.5V	26.5 - 30.0V	31.5 - 34.5	53.0 - 59.5	
OUTPUT CURRENT (NOMINAL) <sup>(1)</sup>	20A	20A	8.5A	7.0A	4.5A (6.5A Peak) <sup>(4)</sup>	3.8A	2.1A	
CURRENT LIMIT <sup>(2)</sup>	26.2A min	21.0A min	8.92A min	7.35A min	6.82A min	3.99A min	2.2A min	
OUTPUT POWER (MAX.) <sup>(3)</sup>	68W	100W	99.6W	99W	100.8W	98W	96W	
EFFICIENCY (typ.)	100 Va-c	74%	77%	80%	80%	81%	81%	83%
	240 Va-c	77%	82%	84%	84%	85%	85%	86%
RIPPLE AND NOISE <sup>(5)</sup> (mV p-p) 0-40°C, 10-100% LOAD	switching (max)	80	80	100	100	100	100	130
	spike noise (max) (d-c—50MHz)	<120	<120	<150	<150	<150	<150	<200

(1) Derates same as Output Power.

(2) Current Limit is rectangular. After the overload is removed, output is automatically restored.

(3) See power derating curve, Figure 4.

(4) Peak current and thermal protection; applicable to 24V model only. See Figure 1 for peak power requirements.

(5) Ripple and noise will be approximately 1.5 times higher when operating temperature range is between -10°C to 0°C.

#### INPUT:

##### Voltage:

Nominal: 120V a-c/240V a-c;

##### Range:

90-264V a-c;

125-370V d-c. (polarity insensitive)

Frequency: Nominal: 50-60 Hz; Range: 47-440Hz  
(From 66 to 440 Hz leakage current may exceed UL/VDE safety spec. limit.)

##### Current (nominal output at rated load):

1.4A a-c max @ 120V a-c rms  
1.2A max for 3.3V model

0.7A a-c max @ 240V a-c rms  
0.6A max for 3.3V model

Initial Turn-on Surge: cold start 25°C (First surge only, not including the current flow into the EMI filter):

14A typ. @ 100 V a-c, 100% load  
28A typ. @ 200 Va-c, 100% load

Power Factor: 0.99 typ. @ 100V a-c;  
0.95 typ. @ 200V a-c.

Switching Frequency:  
135KHz typical

#### STABILIZATION:

Source Effect (full load): 0.2% typ.; 0.3% max.  
Range 90-132V a-c, 170 -264V a-c,

Load Effect (10% to 100% load change):  
0.5% typ.; 1.5% max.

Temperature Effect: Range -10° to 71°C  
0.5% typ.; 1.0% max.

Combined Effect (includes source, load, and temperature effects):  
0.9% typ.; 1.8% max.

Time Effect (1/2 hr-8 hr at 25°C):  
0.2% typ.; 0.5% max.

RECOVERY CHARACTERISTICS: A step load change from 50% to 100% produces less than ±4% output excursion. Recovery occurs to within ±1% of the original setting in <1 ms (load change  $t_r$  or  $t_f$  equal to or greater than 50µsec).

#### START-UP TIME:

500 ms. maximum @ 100V a-c  
300 ms. typical @ 100V a-c  
200 ms. maximum @ 240V a-c  
100 ms. typical @ 240V a-c

### III — SPECIFICATIONS (STANDARD) - CONTINUED

#### HOLDUP TIME:

37 ms. typ., 20 ms. min. (100V a-c)  
 45 ms. typ., 25 ms. min. (240V a-c)

#### DIELECTRIC STRENGTH:

Between input and output:  
 2KV a-c for one minute.  
 Between input and case (ground):  
 2KV a-c for one minute.  
 Between output and case (ground):  
 [500V a-c for one minute.]

INSULATION RESISTANCE: Between input and ground, output and ground, input and output:  
 100 Megohms min. (500V d-c).

#### LEAKAGE CURRENT

0.23mA typical, 0.35 mA maximum  
 (per IEC 950 and UL1950, 120V a-c)  
 0.45mA typical, 0.70 mA maximum  
 (per IEC 950 and UL1950, 240V a-c)

SAFETY: Units are designed to meet UL60950 3rd Edition, CSA 22.2 No. 60950 [60950-1], and EN60950 and are CE marked per the Low Voltage Directive (LVD), 73/23/EEC and 93/68/EEC. The standards do not apply with DC input operation.

EMI: Designed to meet FCC Class B (100-120V a-c) and VDE 0871 Class B (220-240V a-c).

VIBRATION: (non-operating, one hour on each one of the three axes):

5-10 Hz, 10 mm amplitude.  
 10-55 Hz, 2g acceleration.

SHOCK: (non-operating, one-half sinusoidal pulse, three shocks to each axis):

Acceleration: 60g  
 Duration: 11ms  $\pm$ 5ms

OPERATING TEMPERATURE: See Figure 4.

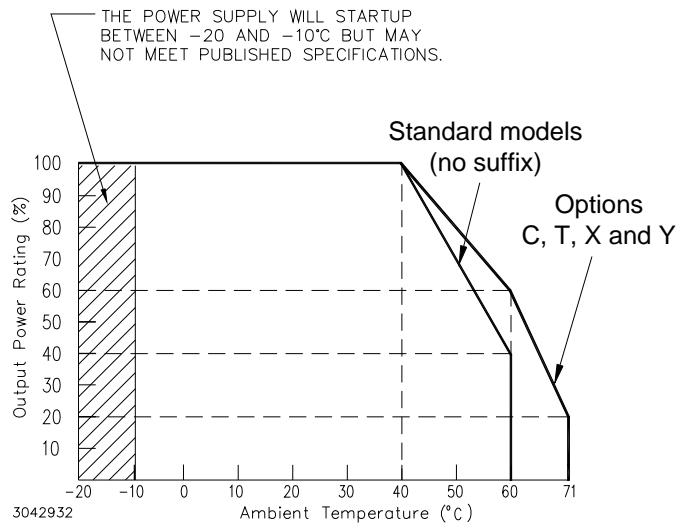

FIGURE 4. % OUTPUT POWER RATING VS. AMBIENT TEMPERATURE

STORAGE TEMPERATURE: -30°C to +75°C.

RELATIVE HUMIDITY: Operating and storage: up to 95% (wet bulb temp. <35°C non-condensing).

ALTITUDE: 0 -10,000 feet (operating),  
 0 - 65,000 feet (storage)

FUSE: Slow Blow, 3.15A, 250V; (5 x 20 mm),  
 Littelfuse, P/N 2153.15PF;  
 Kepco P/N 541-0135.

DIMENSIONS: See Figure 6.

WARRANTY: 5 years.

## IV — SPECIFICATIONS (C, T, X, Y)

The following specifications apply to all HSF-PFCC, PFCT, PFCX, and PFCY (suffix C, T, X, Y) 100 Watt Series models. Table 2 lists the specifications that differ for each model. Common specifications that apply to all

suffix C, T, X, Y models are listed in the paragraphs following Table 2.

**NOTE:** Specifications apply to all models except where otherwise indicated.

**TABLE 2. OUTPUT RATINGS AND SPECIFICATIONS, HSF-PFC 100W SERIES (SUFFIX C, T, X, Y ONLY)**

MODEL	HSF 3.3-25 <sup>(1) (2) (7)</sup>	HSF 5-20 <sup>(1)</sup>	HSF12-8.4 <sup>(1)</sup>	HSF 15-6.7 <sup>(1)</sup>	HSF 24-4.2 <sup>(1)</sup>	HSF 28-3.5 <sup>(1)</sup>	HSF 48-2 <sup>(1)</sup>
	PFCC PFCT PFCX PFCY	PFCC PFCT PFCX PFCY	PFCC PFCT PFCX PFCY	PFCC PFCT PFCX PFCY	PFCC PFCT PFCX PFCY	PFCC PFCT PFCX PFCY	PFCC PFCT PFCX PFCY
OUTPUT VOLTS, d-c (NOMINAL)	3.3V	5V	12V	15V	24V	28V	48V
ADJUSTMENT RANGE	2.8 - 3.5V	4.3 - 5.3V	11.4 - 12.6V	13.5 - 16.5V	19.2 - 26.0V	26.5 - 29.5V	44.0 - 52.0V
OVERVOLTAGE SETTING (25°C, Nom. Input)	3.4 - 4.6V	5.2 - 6.5V	13.2 - 15.2V	16.8 - 18.8V	26.5 - 30.0V	29.7 - 34.7V	54.5 - 59.5V
OUTPUT CURRENT (NOMINAL) <sup>(3)</sup>	25A <sup>(3)</sup>	20A	8.4A	6.7A	4.2A	3.5A	2A
CURRENT LIMIT SETTING w(25°C, Nom. Input) Rectangular type characteristic	26.2A min.	21.0A min.	8.82A min.	7.03A min.	4.68A min.	3.8A min.	2.2A min.
OUTPUT POWER (MAXIMUM) <sup>(4)</sup>	82.5W	100W	100.8W	100.5W	100.8W	100.8W	100.8W
EFFICIENCY (typ.)	100 Va-c	79%	83%	84%	85%	85%	86%
	240 Va-c	81%	85%	86%	87%	87%	88%
RIPPLE AND NOISE <sup>(5)</sup> (mV p-p) 0-40°C, 10-100% load	switching (max)	80	80	100	100	150	200
	spike noise (max) (d-c—50MHz)	120	120	150	150	200	300
Sense Resistor Value (milliohms) <sup>(6)</sup>	5	5	10	20	20	30	50

(1) Unless otherwise noted, specifications are identical for all options.

(2) Forced current Share not available for 3.3V Models.

(3) Derates same as Output Power.

(4) See power rating curve, Figure 3.

(5) Ripple and noise will be approximately 1.5 times higher when operating temperature range is between -10°C to 0°C.

(6) Sense resistor on C and Y Models used for current monitoring. See "Current Monitor." on page 2 for details.

(7) Natural convection cooled; see Figure 4.

### INPUT:

#### Voltage:

Nominal: 120V a-c/240V a-c;

#### Range:

90-264V a-c;

125-370V d-c. (polarity insensitive)

Frequency: Nominal 50-60 Hz; Range 47-440Hz

(From 66 to 440Hz leakage current may exceed UL/VDE safety spec. limit)

Current (nominal output at rated load):

1.5A a-c max @100-120V a-c rms  
1.1A max for 3.3V model

0.75A a-c max @200-240V a-c rms  
0.55A max for 3.3V model

Initial Turn-on Surge: cold start 25 °C (First surge only, not including the current flow into the EMI filter):

14A typ. (100 V a-c, 100% load)  
28A typ. (200 Va-c, 100% load)

Power Factor: 0.99 typ. @100V a-c;

0.92 typ. @ 200V a-c.

Switching Frequency:

160KHz typical

### STABILIZATION:

Source Effect (full load):

Range 90-132V a-c or 170 -264V a-c,  
0.1% typ.; 0.2% max.  
3.3V model: 5mV typ., 10mV max.

Load Effect (10% to 100% load change):

0.5% typ.; 1.5% max.  
3.3V, 5V models: 1.5% typ., 2.0% max.

Temperature Effect: Range -10° to 71°C

0.5% typ.; 1.0% max.

Combined Effect (includes source, load, and

temperature effects):  
0.9% typ.; 1.8% max.

Time Effect (1/2 hr-8 hr at 25°C):

0.2% typ.; 0.5% max.

## IV — SPECIFICATIONS (C, T, X, Y) - CONTINUED

RECOVERY CHARACTERISTICS: A step load change from 50% to 100% produces less than  $\pm 4\%$  output excursion. Recovery occurs to within  $\pm 1\%$  of the original setting in  $< 1$  ms (load change  $t_r$  or  $t_f$  equal to or greater than  $50\mu\text{sec}$ ). (3.3V: 200mV max.)

START-UP TIME: 500 ms. maximum @100V a-c  
400 ms. typical @100V a-c  
300 ms. maximum @240V a-c  
200 ms. typical @240V a-c

HOLDUP TIME:  
37 ms. typ., 20 ms. min. (100V a-c)  
30 ms. typ., 20 ms. min. (240V a-c)

DIELECTRIC STRENGTH:  
Between input and output:  
2KV a-c for one minute.  
Between input and case (ground):  
2KV a-c for one minute.  
Between output and case (ground):  
500V a-c for one minute.

INSULATION RESISTANCE: Between input and ground, output and ground, input and output:  
100 Megohms min. (500V d-c).

LEAKAGE CURRENT (per IEC 950 and UL 1950)  
0.13mA typ. 0.19 mA maximum, (120V a-c)  
0.45 mA maximum (240V a-c)

SAFETY: Units are designed to meet UL60950 3rd Edition, CSA 22.2 No. 60950-1, and EN60950:2001 and are CE marked per the Low Voltage Directive (LVD), 73/23/

EEC and 93/68/EEC. The standards do not apply with DC input operation.

EMI: Designed to meet FCC Class B (100-120V a-c) and VCCI, EN55011-B, EN55022-B.

VIBRATION: (non-operating, one hour on each one of the three axes):  
5-10 Hz, 10 mm amplitude.  
10-55 Hz, 2g acceleration.

SHOCK: (non-operating, one-half sinusoidal pulse, three shocks to each axis):  
Acceleration: 60g  
Duration: 11ms  $\pm 5$ ms

OPERATING TEMPERATURE: See Figure 4.

STORAGE TEMPERATURE:  $-30^{\circ}\text{C}$  to  $+75^{\circ}\text{C}$ .

RELATIVE HUMIDITY: Operating and storage: up to 95% (wet bulb temp.  $< 35^{\circ}\text{C}$  non-condensing).

FUSE: Slow Blow, 3.15A, 250V; (5 x 20 mm), Littelfuse, P/N 2153.15PF;  
Kepco P/N 541-0135.

DIMENSIONS: See Figure 6.

WARRANTY: 5 years.

## V — INSTALLATION

**MOUNTING THE POWER SUPPLY.** Refer to Figure 2 and insert power supply into selected slot of RA 19-(X)B Rack adapter until power supply front panel is flush with rack adapter chassis and secure with front panel Phillips head mounting screw.

**CONNECTIONS.** All connections are made at the rear panel of the RA 19-(X)B Rack Adapter (see applicable RA 19-(X)B Operator Manual). Connect the load to the applicable  $\pm$  DC OUTPUT terminals. AC input power to each

slot is applied via two INPUT POWER terminal blocks as indicated on the rack adapter rear panel. Make sure to connect the AC input Neutral, Line and Ground wires to the respective terminals of the terminal blocks.

**REMOVAL.** To remove a power supply, first use the POWER switch to turn off the unit. Then loosen the mounting screw and extract the unit from the RA 19-(X)B Rack Adapter.

## VI — OPERATION

Turn the unit on using the front panel POWER switch (see Figure 5). **CAUTION: DO NOT repeatedly toggle the POWER on/off switch as this may cause unit to fault.**

When output voltage is available, the green VDC ON LED is on. While monitoring output voltage at the front panel test points, the Output Voltage Adjust trimmer allows adjustment of the output voltage.

Master/slave parallel configurations of one or more power supplies are covered in the applicable RA 19-(X)B Rack Adapter manual.

The MASTER ON LED (amber) goes on under any of the following three conditions:

- Independent operation.
- Operation in a parallel master/slave configuration to indicate which unit is the master
- Operation in a parallel master/slave configuration to indicate that a slave unit is no longer within the proper specifications for paralleled units. Slave 1 should be optimally adjusted to 40mV less than master, slave 2 adjusted to 40mV less than slave 1, etc. The maximum allowable difference between paralleled units is 250mV. The minimum allowable difference between paralleled units is 25mV. If a slave exceeds these limits, the MASTER ON light goes on.

**NOTE:** MASTER ON LED not used on 3.3V model: always OFF.

Additional information for various parallel and alarm configurations can be found in the applicable RA 19 Rack Adapter manual referenced on page 1.

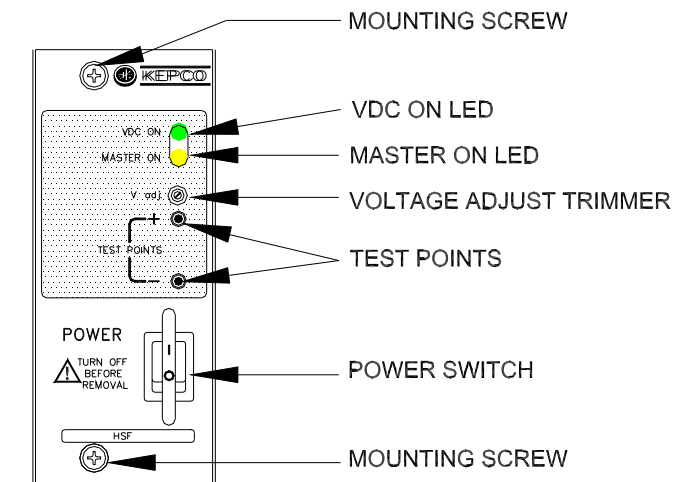

3043428

**FIGURE 5. COMPONENT LOCATIONS**



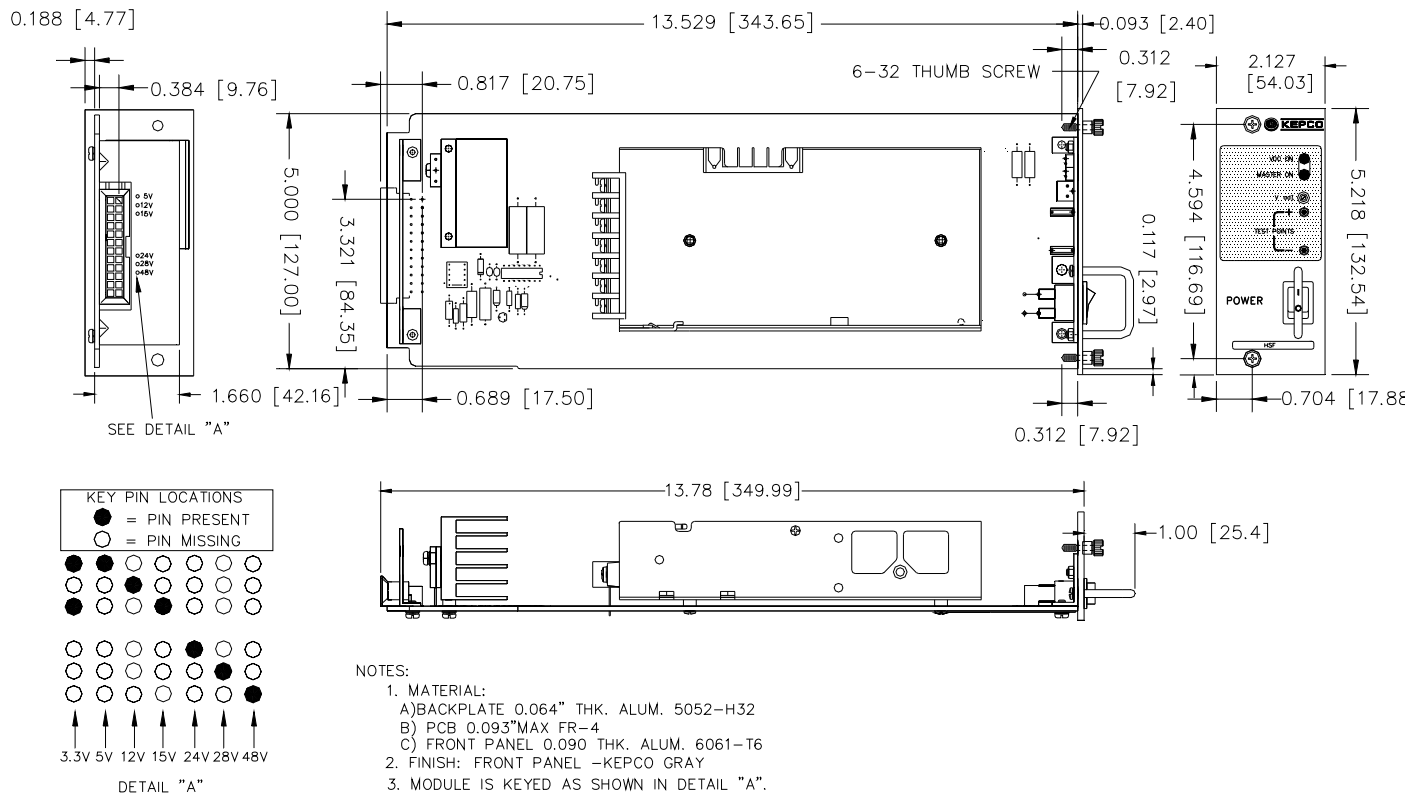

NOTES:  
 1. MATERIAL:  
 A) BACKPLATE 0.064" THK. ALUM. 5052-H32  
 B) PCB 0.093" MAX FR-4  
 C) FRONT PANEL 0.090 THK. ALUM. 6061-T6  
 2. FINISH: FRONT PANEL -KEPCO GRAY  
 3. MODULE IS KEYED AS SHOWN IN DETAIL "A".

3042658

**FIGURE 6. HSF-PFC 100W (INCLUDING SUFFIX C, T, X AND Y) POWER SUPPLY OUTLINE DRAWING**