

# OPERATOR MANUAL

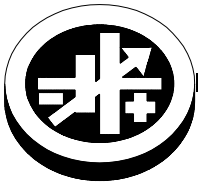

**KEPCO** An ISO 9001 Company.

**JBW**  
**150W SERIES**  
CE

## 150 WATT SINGLE OUTPUT SWITCHING POWER SUPPLIES

### I — INTRODUCTION

**SCOPE OF MANUAL.** This instruction manual covers the installation and operation of the Kepco JBW 150W Series of RoHS (Reduction of Hazardous Substances) compliant Switching Power Supplies.

**DESCRIPTION.** The Kepco JBW 150W Series consists of four models of switching power supplies, each with a single output as shown in Table 1. Units may be operated with a nominal 100 to 120V a-c and 220 to 240V a-c (input voltage range 85 to 265 Va-c), 50-60 Hz (input frequency range 47-440Hz.) They will also operate on 120V to 370V d-c input. The JBW 150W Series employs a light weight ferrite core. Regulation is provided by pulse width modulation. A FET power stage, operating as a forward converter with a fixed switching frequency of 130kHz provides a smooth isolated d-c output. Power Factor Correction (PFC) is provided

by a boost converter operating at 80kHz. A thermistor circuit prevents excessive turn-on current surge. Overvoltage protection is provided. Current limiting with automatic recovery from short circuit is featured. Units are manufactured on an open frame PC board.

Table 1 contains specifications and operating limits of individual JBW 150 Series models. Section II (following) contains specifications and operating limits common to all JBW 150W Series Models

### II — SPECIFICATIONS

The following specifications are at nominal input voltages and 25°C and apply to all models unless otherwise specified.

**TABLE 1. OUTPUT RATINGS AND SPECIFICATIONS, JBW 150W SERIES**

| MODEL   |                                   | JBW 5-30K  | JBW 12-12K | JBW 15-10K | JBW 24-6.3K                 |
|---|-----------------------------------|------------|------------|------------|-----------------------------|
| OUTPUT VOLTS, d-c   |                                   | 5V ±0.25V  | 12V ±0.6V  | 15V ±0.75V | 24V ±1.2V                   |
| ADJUSTMENT RANGE  |                                   | 4.5-5.5V   | 10.8-13.2V | 13.5-16.5V | 21.6-26.4V                  |
| CURRENT/MAX. POWER RATINGS  |                                   | 30.0A/150W | 12.5A/150W | 10A/150W   | 6.3A <sup>(1)</sup> /151.2W |
| OVERCURRENT (AMPS)  |                                   | 31.5 min.  | 15.7 min.  | 12.5 min.  | 7.87 min                    |
| OVP RANGE (VOLTS)   |                                   | 5.75-6.9   | 13.8-16.8  | 17.2-21.0  | 27.6-33.6                   |
| EFFICIENCY (typ.)   | 100 Va-c                          | 78%        | 81%        | 81%        | 82%                         |
|   | 240 Va-c                          | 80%        | 83%        | 83%        | 84%                         |
| ACCEPTABLE EXTERNAL OUTPUT CAPACITOR<br>µFmax., (fixed load resistance) |                                   | 30,000     | 30,000     | 30,000     | 30,000                      |
| RIPPLE AND<br>NOISE <sup>(2)</sup><br>(mV p-p max.)                     | ripple (typ)                      | 80         | 120        | 120        | 120                         |
|   | ripple (typ) (-10 to 0°C)         | 140        | 160        | 160        | 160                         |
|   | spike noise (typ)                 | 120        | 150        | 150        | 150                         |
|   | spike noise (typ)<br>(-10 to 0°C) | 160        | 180        | 180        | 180                         |

(1) 7.5A peak, t ≤ 10 seconds, not to exceed 6.3A rms, output power ≤ 150W.

(2) 0 to 100% load, 0 to 60 °C, tested with 100µF electrolytic and 0.1µF film capacitors across the measuring points, connected to the power supply via 5.9 in (150mm) wires; oscilloscope bandwidth ≤ 20MHz.

#### INPUT CHARACTERISTICS:

##### INPUT VOLTAGE: (0 to 100% load, -10 to 60°C)

Nominal 100-120V a-c, 220-240V a-c

Range: 85-265V a-c, 120 -370V d-c

**NOTE:** The power supply may shut down if operated at below the input voltage range or if the input voltage increases slowly at start up (> 1 second). To reset the power supply, unplug the unit, wait one minute and reapply input power.

##### INPUT SOURCE FREQUENCY:

Nominal 50/60 Hz;

Range 47-66 Hz (Above 66Hz to 440 Hz the leakage current may exceed the VDE safety specification limit.)

##### INPUT CURRENT: (100% load at 25°C with nominal output voltage):

100V a-c input: 2.0A typ., 2.7A max.

240V a-c input: 1.0A typ., 1.5A max.

**INPUT PROTECTION AND SOFT START:** A thermistor circuit reduces start-up surge. Units are protected against shorts by an input fuse. Fuse value 5A, 250V.

##### INPUT SURGE: Cold start:

100V a-c input, 100% load: 15A typ., 30.0A max.

240V a-c input, 100% load: 30A typ., 60.0A max.

KEPCO, INC. • 131-38 SANFORD AVENUE • FLUSHING, NY. 11355 U.S.A. • TEL (718) 461-7000 • FAX (718) 767-1102

<http://www.kepcopower.com> • email: [hq@kepcopower.com](mailto:hq@kepcopower.com)

**LEAKAGE CURRENT:**

100V a-c and 60 Hz (single pole switching) (operating in conformance with Den-An):

0.75mA max, 0.20mA typ

240V a-c and 60 Hz (single pole switching in conformance to UL 1950/IEC 950):

0.75mA max, 0.30mA typ

**POWER FACTOR:**

100V a-c: 0.99 typ.

240V a-c: 0.95 typ.

**OUTPUT CHARACTERISTICS:****SOURCE EFFECT:** (85 to 265 Va-c)

0.4% max.

**LOAD EFFECT:** measured at sensing terminals

(0% - 100% load change)

0.8% max.

**TEMPERATURE EFFECT:** (-10 to 60°C)

1.0% max.

**COMBINED EFFECT:**

2.0% max. (4% typical for overshoot at start-up)

**TIME EFFECT OR DRIFT:** (1/2 to 8 hr. at 25°C)

0.4% max.

**TRANSIENT RECOVERY:** A step load change from 50% to 100% of rated load in 50 microseconds or more produces no more than 4% output voltage excursion. Temperature range from -10 to 60°C. Recovery time is 1mS maximum.

**HOLD UP TIME:** Condition: 100% output load. Upon input interruption the output is maintained for:

100 Va-c: 25mS typ.

240 Va-c: 35mS typ.

**START UP TIME:**

100 Va-c: 500mS max., 400mS typ.

240 Va-c: 500mS max., 300mS typ.

**OVERVOLTAGE PROTECTION:** Fixed, factory set. See Table 1. Latching will occur.

**OVERCURRENT:** Square type, output voltage returns to rated level upon removal of cause of malfunction (long term overcurrent could damage unit).

**ENVIRONMENTAL CHARACTERISTICS**

**OPERATING TEMPERATURE:** -10 to 60°C (start up -20 to -10°C). See the derating, Figure 1.

**STORAGE TEMPERATURE:** -30°C to + 75°C.

**COOLING:** Natural convection. Do not allow the power supply to become dust covered because that will decrease the cooling efficiency of the unit and cause insulation to deteriorate.

**ORIENTATION:** Vertical or horizontal (see Figure 2).

**HUMIDITY:** 10% to 90% relative humidity, operating and storage, noncondensing, wet bulb temperature < or = 35°C.

**VIBRATION:** Three axes, one hour each, sweep time 10 min., nonoperating.

5-10 Hz., 10 mm amplitude

10-200 Hz., 2G (19.6m/s<sup>2</sup>) acceleration

**SHOCK:** Three axes, 60G (588m/s<sup>2</sup>), 11mS ±5mSec pulse duration, three shocks each axis, nonoperating, 1/2 sine pulse.

**GENERAL CHARACTERISTICS**

**WITHSTANDING VOLTAGE:** (at 5 to 35°C ambient, 45 to 85% relative humidity, cutout current 10 mA):

Between input and output terminals:

3.0 KV a-c for 1 minute.

Between input terminals and ground:

2000V a-c for 1 minute.

Between output terminals and ground:

500V a-c for 1 minute.

**INSULATION RESISTANCE:** Between input and output, input and ground, output and ground: 100 megohms minimum (500V d-c, 5 to 35°C ambient, 45 to 85% relative humidity)

**SAFETY:** All units designed to meet UL 60950-1.c, and TÜV Rheinland EN60950-1 (ambient temp. 50°C max.). JBW 150W units are CE marked per the Low Voltage Directive (LVD), EN60950.

**EMC - EMISSIONS:**

- Conducted Noise: 0.15MHz to 30MHz: FCC Class B, VCCI-B, EN55011-B, EN55022-B.
- Input Harmonics (on AC Mains) 0 to 2kHz: EN 61000-3-2.

**EMC - IMMUNITY:** Designed to meet EN 61000-6-2.

- ESD: EN 61000-4-2 Level 4, Normal operation.
- Radiated Field Noise: EN 61000-4-3 Level 3, Normal operation.
- Electrical Fast Transient/Burst (EFT): EN 61000-4-4 Level 3, Normal operation.
- Surge: EN 61000-4-5 Level 4, no damage.
- Conducted Noise: EN 61000-4-6 Level 3, Normal operation.
- Power Frequency Magnetic Field: EN 61000-4-8 Level 4, Normal operation.
- Interruptions and voltage dips, short variations: EN 61000-4-11, Normal operation.

**WARRANTY:** One year.

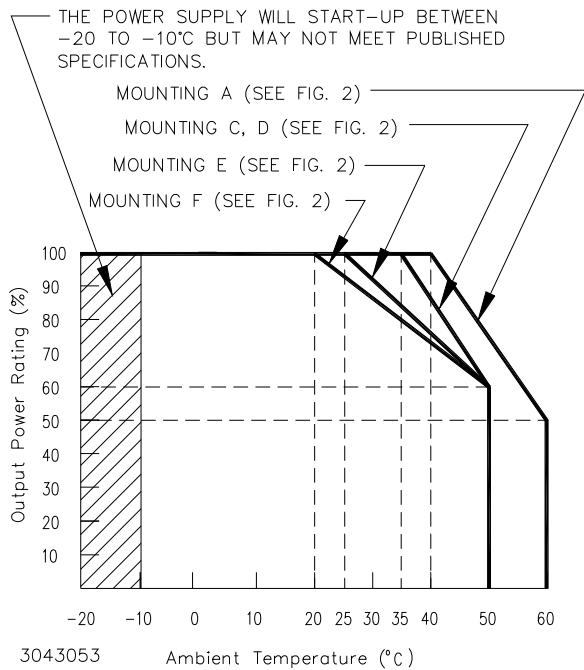

**FIGURE 1. OUTPUT POWER VS. TEMPERATURE**

### III — INSTALLATION

**MOUNTING POWER SUPPLY.** Refer to Figures 2, 3 and 4. The unit may be mounted on one mounting surface. Air temperature surrounding the power supply must not exceed the ambient values given in the graph in Figure 1.

**INSULATION.** Install unit at least 0.3 inches (8mm) away from base with 0.24 inch (6mm) diameter spacers attached to the PC board. Keep at least 0.16 inches (4mm) spacing around and above the unit to comply with insulation and safety requirements. An insulator must be used if the spacing is less than 0.16 inches (4mm) (see Figure 3).

**VENTILATION.** It is recommended to keep at least 0.40 inches (10mm) clearance from adjacent equipment for proper ventilation (see Figure 3).

**CONNECTIONS.** Connect a load to the output of the power supply by connecting pins 1 through 6 (+) of output connector CON2 to the load (+) terminal, and pins 1 through 7 (-) of output connector CON2 to the load (-) terminal. See Figure 4 for input/output connector and pin locations. When connecting the power supply to the load, keep the wires as short as possible, and use twisted pairs (use Wire Size AWG No. 22). Make sure there is only a single ground point in the load circuit. Capacitors (100UF electrolytic and 0.1UF film) can be placed across the load to filter out noise. The AC input power is applied via input connector CON1. Make sure to connect the AC input Neutral and Line wires to pins 3 and 1, respectively, of CON1. See Figure 5 for mating connector information. A Cable Kit (P/N 219-0496) is available as an option from Kepco. The kit includes one input cable, one output (-) cable and one output (+) cable, each one meter long with the mating connectors for Input and Output connectors at one end and unterminated wires at the other end.

### IV — OPERATION

**PROTECTION DIODE:** When a number of power supplies are operating in series, the current rating is to be limited to the rating of the power supply with the lowest rating. A diode ( $V_r > 2 \sum V_o$ ,  $I_f > 2 I_o$ ,  $V_f \ll \text{low}$ ) must be connected to the power supply output terminals to protect the unit from reverse voltage.

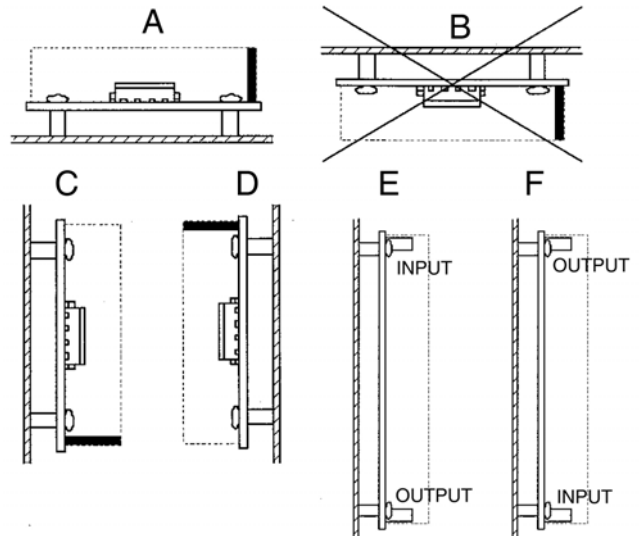

NOTES:

1. METHOD A (STANDARD) RECOMMENDED, APPLY DERATING CURVE PER FIGURE 1.
2. METHOD B IS NOT ALLOWED (INADEQUATE COOLING).
3. FOR METHODS C, D, E, AND F, APPLY DERATING CURVE PER FIGURE 1.

3043049

**FIGURE 2. MOUNTING DIRECTION**

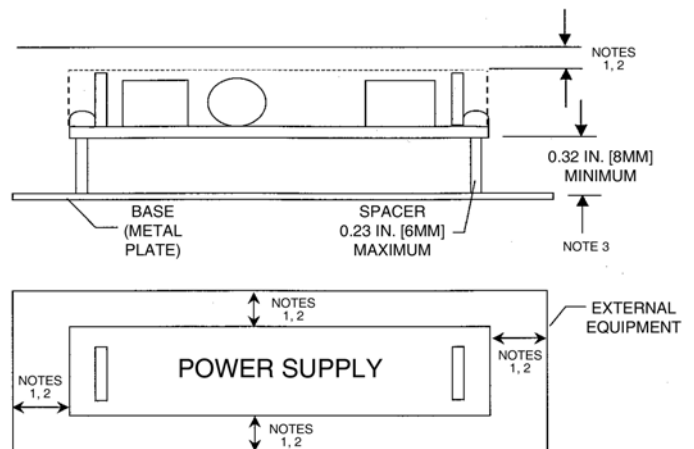

NOTES:

1. MAINTAIN MINIMUM 0.16 IN. [4 MM] CLEARANCE TO SATISFY INSULATION AND WITHSTAND VOLTAGE REQUIREMENTS; OTHERWISE USE ADEQUATE INSULATOR.
2. MINIMUM 0.39 IN. [10MM] CLEARANCE RECOMMENDED FOR ADEQUATE COOLING.
3. INSTALL POWER SUPPLY AT LEAST 0.32 IN. [8MM] ABOVE BASE USING SPACERS, (MAXIMUM DIA. 0.23 IN. [6MM]).

3043034

**FIGURE 3. VENTILATION AND INSULATION REQUIREMENTS**

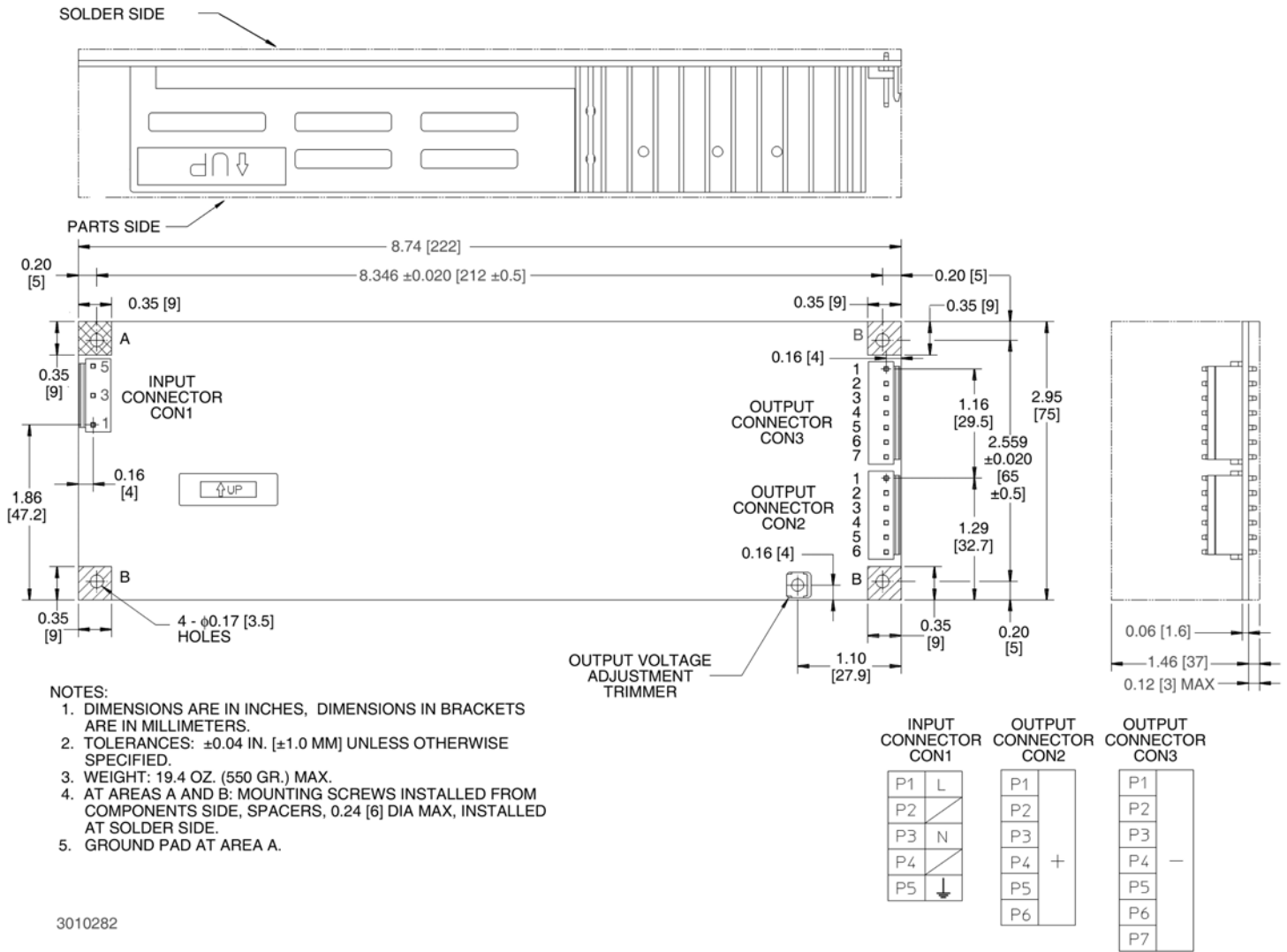

**FIGURE 4. JBW 150W MECHANICAL OUTLINE DIAGRAM**

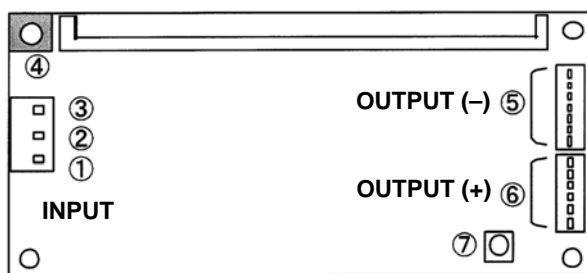

3043055

| Item | Function     |
|------|--------------|
| 1    | Input L      |
| 2    | Input N      |
| 3    | Ground       |
| 4    | Ground Pad   |
| 5    | Output (-)   |
| 6    | Output (+)   |
| 7    | Vadj control |

| Mating Connectors <sup>(3)</sup> |              |                |                    |
|----------------------------------|--------------|----------------|--------------------|
| Connector                        | Terminal Pin | Socket Housing | MFR                |
| Input                            | SVH-21T-P1.1 | VHR-5N         | JST <sup>(1)</sup> |
|                                  | T101         | H101-05        | LCE <sup>(2)</sup> |
| Output (-)                       | SVH-21T-P1.1 | VHR-7N         | JST <sup>(1)</sup> |
|                                  | T101         | H101-07        | LCE <sup>(2)</sup> |
| Output (+)                       | SVH-21T-P1.1 | VHR-6N         | JST <sup>(1)</sup> |
|                                  | T101         | H101-06        | LCE <sup>(2)</sup> |

(1) JST= Japan Solderless Terminal Mfg. Co.

(2) LCE= Long Chu Electronics Co.

(3) Optional cable kit (P/N 219-0496) includes one input and two output cables (one meter long) with mating connectors for Input and Output (+) and (-) connectors, unterminated at other end.

**FIGURE 5. INPUT/OUTPUT CONNECTIONS**