

OPERATOR'S MANUAL

HSF 1200W/1500W POWER SUPPLY

**SINGLE OUTPUT POWER SUPPLIES
SINGLE PHASE, POWER FACTOR CORRECTED
UNIVERSAL AC INPUT, OPTIONAL METER**

KEPCO INC.
An ISO 9001 Company.



**MODEL
HSF 1200W/1500W
POWER SUPPLY**

**HSF 24-50, HSF 36-42, HSF 48-32
HSF 24-50M, HSF 36-42M, HSF 48-32M
HSF 24-50C, HSF 36-42C, HSF 48-32C**

IMPORTANT NOTES:

- 1) This manual is valid for the following Model and associated serial numbers:

MODEL	SERIAL NO.	REV. NO.
HSF 1500W		

- 2) A Change Page may be included at the end of the manual. All applicable changes and revision number changes are documented with reference to the equipment serial numbers. Before using this Instruction Manual, check your equipment serial number to identify your model. If in doubt, contact your nearest Kepco Representative, or the Kepco Documentation Office in New York, (718) 461-7000, requesting the correct revision for your particular model and serial number.
- 3) The contents of this manual are protected by copyright. Reproduction of any part can be made only with the specific written permission of Kepco, Inc.

Data subject to change without notice.

©2015, KEPCO, INC
P/N 228-1589-R4



KEPCO, INC. • 131-38 SANFORD AVENUE • FLUSHING, NY. 11355 U.S.A. • TEL (718) 461-7000 • FAX (718) 767-1102
email: hq@kepcopower.com • World Wide Web: <http://www.kepcopower.com>

TABLE OF CONTENTS

SECTION	PAGE
1. Introduction	1
1.1 Scope of Manual	1
1.2 Description	1
2. Specifications	2
3. Features	5
3.1 DIP Switch Configuration	5
3.2 Front Panel Access	6
3.3 Keying	6
3.4 Output Voltage Control	7
3.4.1 Front Panel Voltage Control	7
3.4.2 Remote Voltage Control	7
3.5 Current Monitor (C and M Suffix only)	8
3.6 Remote On-Off	9
3.7 Protection Circuits	9
3.7.1 Overvoltage And Overtemperature Protection	9
3.7.2 Overcurrent/Current Limit Setting and Protection	10
3.7.3 Fan Failure	10
3.7.4 Undervoltage	10
3.8 Alarm Settings	10
3.8.1 Visual Alarm	10
3.8.2 Alarm Signals	10
3.8.2.1 Internal Isolated Relay Alarm	10
3.8.2.2 Optically-Coupled Logical Alarm	11
3.9 Retaining Latches	12
4. Load Connection	12
5. Connecting Multiple Power Supplies	12

LIST OF FIGURES

FIGURE	TITLE	PAGE
1	RA 19-4C Rack Adapter I/O Connector	1
2	Power Rating Vs. Temperature	3
3	Mechanical Outline Drawing Of HSF 1200W/1500W Power Supply	5
4	DIP Switch Configuration	6
5	Front Panel Controls, Indicators and Test Points	7
6	DIP Switch Settings for Control of Output Voltage	8
7	Connections For Remote Voltage Control	9
8	DIP Switch Settings for Using RESET button or Remote ON-OFF	9
9	DIP switch settings for Optically Coupled Logical Alarm	11
10	Output Alarm Circuit Optically Isolated	11
11	±PF Power Failure Optocoupler Timing Diagram	11
12	Correct and incorrect Methods of Load Connection	12

LIST OF TABLES

TABLE	TITLE	PAGE
1	Rear Connector Pin Assignments	1
2	Output Ratings and Specifications	2
3	Power Supply Ratings and Specifications	3
4	Minimum Conditions for Relay, Meter and LED Operation	8

1. INTRODUCTION

1.1 SCOPE OF MANUAL

This Operator's Manual covers the installation and operation of the Kepco HSF 1200W/1500W Series of Switching Power Supplies. For service information, write directly to: Kepco Inc., 131-38 Sanford Avenue, Flushing, New York, 11355, U.S.A. Please state Model Designation and Serial Number of your HSF Power Supply (see nameplate of the unit).

1.2 DESCRIPTION

The Kepco HSF1500 Watt Series are hot swappable, high frequency switching, plug-in power supplies. Metered models (M suffix) are completely interchangeable with the non-metered HSF Series. Three models may be selected for outputs of 24V (1200W), 36V or 48V (1500W). They employ forward conversion and power factor correction and are designed to operate in a fault tolerant power system with a nominal a-c input of 100V a-c to 240V a-c (input voltage range 85 to 265V a-c), 50-60Hz (input frequency range 47-440Hz). A built-in current balancing circuit and OR-ing diodes allow configuration for hot-swap and parallel-redundant N+1 operation.

These power supplies are designed to be used with Kepco's Series RA 19-4C rack adapters. The RA 19-4C rack adapter accepts up to four 1200W (24V) or 1500W (36V, 48V) modules. All input/output connections are through a 24-pin connector that plugs in to the rack adapter. All external connections are made through the rack adapter's I/O connector (see Figure 1).

An optional meter (M suffix) provides digital indication of voltage or current (switch selectable) from the front panel. An optional current sense resistor (C suffix) allows external current monitoring within 3% (contact Kepco if greater accuracy is required). RoHS-compliant models indicated by HSF* (e.g., HSF 24*50M).

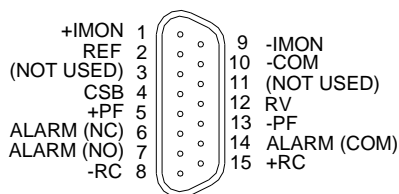

**RA 19-4C RACK ADAPTER
I/O CONNECTOR**

3042866

FIGURE 1. RA 19-4C RACK ADAPTER I/O CONNECTOR

TABLE 1. REAR CONNECTOR PIN ASSIGNMENTS

Signal Name	Pin	Function
Output +	1, 2, 4	DC output (+) applied to load.
Output -	3, 5, 6	DC Output (-) applied to load.
IMON+	8	Current Monitor+ (used on C and M suffix only).
NO	10	Normally Open contact of alarm relay, referenced to AL COM, pin 14 (see PAR. 3.8.2).
IMON-	11	Current Monitor- (used on C and M suffix only).
-COM	12	-Signal Common provides return for REF, pin 15, and RV, pin 18, signals.
NC	13	Normally Closed contact of alarm relay, referenced to AL COM, pin 14 (see PAR. 3.8.2).
AL COM	14	Common contact of alarm relay (see PAR. 3.8.2).
REF	15	Reference voltage. When used with RV, pin 18, allows all output voltages of paralleled slave supplies to be controlled by one voltage adjustment of a master power supply. When REF is connected to RV, the front panel Vadj control determines output voltage. Connections are made via DIP switches (see PAR. 3.1).
+PF	16	+Power Fail of open-collector alarm circuit. Used with -PF, pin 19 (see PAR. 3.8.2).
CSB	17	Current Share Bus - Used whenever several power supplies are connected in parallel (see PAR. 5.).

TABLE 1. REAR CONNECTOR PIN ASSIGNMENTS (CONTINUED)

Signal Name	Pin	Function
RV	18	Remote Voltage - Used with REF, pin 15, for remotely controlling the output voltage (see PAR. 3.4.2)
-PF	19	-Power Fail of open-collector alarm circuit. Used with +PF, pin 16 (see PAR. 3.8.2).
+RC	20	+Remote On-off used with -RC, pin 21, to allow remote turn-on turn-off of the unit (see PAR. 3.6)
-RC	21	-Remote On-off used with +RC, pin 20, to allow remote turn-on turn-off of the unit (see PAR. 3.6)
GND	22	AC input ground
N	23	AC Input neutral
L	24	AC input line

2. SPECIFICATIONS

Table 2 contains specifications and operating limits of individual HSF 1200W/1500W Series models. Table 3 contains specifications and operating limits common to all HSF 1200W/1500W Series Models. These specifications are at nominal input voltages at 25°C and apply to all models unless otherwise specified.

TABLE 2. OUTPUT RATINGS AND SPECIFICATIONS

MODEL		HSF 24-50	HSF 36-42	HSF 48-32
Output Volts d-c (nominal)		24	36	48
Adjustment Range	Front panel Trimpot (Volts)	16.8-30.5	15.0-48.0	33.6-54.0
	5K ohm Trimpot with RV terminal (Volts)	16.8-30.5	6.0-48.0	33.6-54.0
	Using Voltage source (Volts)	18 - 30	6.1-54	33.6 - 55.2
	Voltage source range (Volts)	3.5 - 6.5	0-5.75	3.5 - 5.75
Maximum Output Ratings ⁽¹⁾ (A,W)	85-90V a-c Input:	30-35A/720-840W	N/A	N/A
	85-95V a-c Input:	N/A	21-25.2A/756-907W	16-19.2A/(768-922W)
	90-170V a-c Input:	35A/840W	N/A	N/A
	95-170V a-c Input:	N/A	25.2A/907W	19.2A/922W
	170-265V a-c Input:	50A/1200W	42A/1512W	32A/1536W
Overvoltage Protection Level ⁽⁵⁾	At power module output terminals (Volts)	32-35	56-60	56-60
Current Limit Setting (Amps) ⁽²⁾	85 - 90V a-c input	31-57.5 ⁽³⁾	22.3-48.3 ⁽³⁾	17-36.8 ⁽³⁾
	90 - 170V a-c input	36-57.5 ⁽³⁾	26-48.3 ⁽³⁾	20-36.8 ⁽³⁾
	170 - 265V a-c input	52.5-57.5 ⁽⁴⁾	44.1-48.3 ⁽⁴⁾	33.6-36.8 ⁽⁴⁾
Efficiency % typical	AC Input 100V	83	81	85
	AC Input 200V	85	86	88
Ripple & Noise ⁽⁶⁾ (mV, p-p)	ripple	250	350	350
	ripple noise	350	450	450
Sense Resistor (I _{Mon}) values (Ohms)		0.002	0.002	0.005

- (1) See Figure 2 for power derating vs. temperature and input voltage.
- (2) Current limit value determined by the combination of input voltage and output voltage setting. For example, if RKE 48-23K is operated at 120V a-c and output voltage is set at the minimum of output range (33.6V), current limit is closer to the maximum specified value of 36.8A. For the same input voltage (120Vac) if output voltage is set at maximum (55.0V), then the current limit value is closer to 20A (the minimum current limit value specified for input voltage range 90-170V a-c).
- (3) Winker (intermittent) Operation; after cause is removed, output voltage restored automatically, however for some combinations of input voltage and output voltage and current limit characteristics may be square type: see note (4) below.
- (4) Square type. Unit first enters Current Limit; output voltage starts to drop (nearly square curve). If cause is removed while in Current Limit, output voltage restores automatically. If current continues to increase, Overcurrent is triggered. If Overcurrent is combined with an output voltage drop below 60% of rated output voltage (below 5V for 36V model), the unit shuts OFF. Recovery is by removing, then reapplying input power after more than 30 seconds or by opening and (without waiting) reclosing the RC terminals using either the front panel RESET button or an external remote switch.
- (5) When overvoltage is detected, output is shut OFF.
- (6) Ripple and noise levels above are satisfied when conditions are 0 to 100% load, 0 to 65°C (load is derated from 50 to 65°C, see Figure 2), and bandwidth ≤100MHz.

NOTE: Safety agency approvals apply only to operation between -10°C and 40°C.

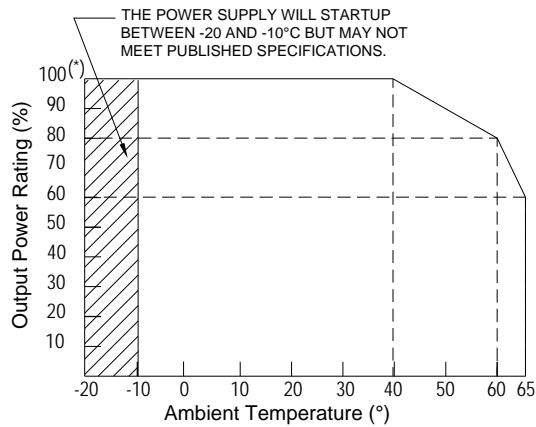

3042855

POWER RATING VS. TEMPERATURE

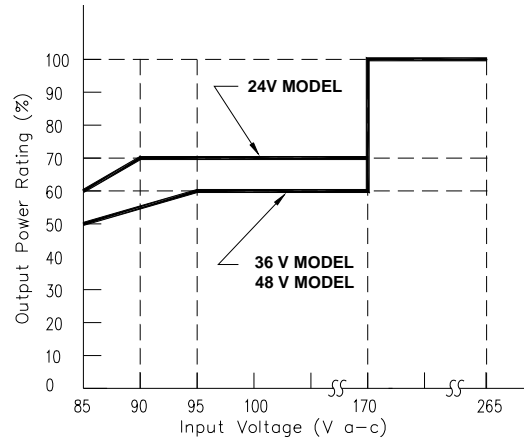

3043277

POWER RATING VS. INPUT VOLTAGE

FIGURE 2. POWER RATING VS. TEMPERATURE

TABLE 3. POWER SUPPLY RATINGS AND SPECIFICATIONS

CHARACTERISTIC	SPECIFICATION	CONDITION/NOTES	
Input Voltage	Nominal: 100-120V a-c, 200-240V a-c Range: 85-264V a-c	0 to 100% load, -10 to 40°C	
Input Source Frequency	Nominal: 50-60 Hz Range: 47-440 Hz	0 to 100% load, -10 to 40°C At 440 Hz leakage current exceeds UL/VDE safety spec. limit.	
Input Current: (Maximum Load At 25°C with Nominal Output Voltage)	13A rms max. (12A max. for 24V model)	100 - 120V a-c	
	10A rms max. (8A rms max for 24V model)	200 - 240V a-c	
Switching Frequency	140KHz	Forward Converter	
Input Protection	A limiting resistor in series with a resistor fuse (and thyristor circuit) reduces start-up surge. The internal power supply is protected against shorts by an input fuse. Fuse value 25.0A At 250 Volts		
Input Surge cold start, interval > 30 sec (First surge only, not including current flow into EMI filter)	15A typ., 20A max. first surge	100 - 120V a-c	
	30A typ., 40 max. first surge	200- 240 V a-c	
Leakage Current:	0.30mA typ., 0.75mA max.	120V a-c, 60Hz per IEC 950 and UL1950	
	0.60mA typ., 0.75mA max.	240V a-c, 60Hz per IEC 950 and UL1950	
Power Factor	0.99 typical	100V a-c, max load, nominal output, per EN 61000-3-2	
	0.95 typical	200V a-c, max load, nominal output per EN 61000-3-2	
Transient Recovery characteristic	excursion ±4% maximum	50% to 100% load, transient time >50µsec	
	recovery time 1 ms maximum		
Stabilization	Source Effect (min - max) ±0.1% Typical, ±0.2% Maximum	85 to 132V a-c, 190 to 264V a-c	
	Load Effect	24V Model: ±2.5% Typical, ±3.0% Maximum	0%-100% load change
		36V Model: ±2.0% Typical, ±2.5% Maximum	
		48V Model: ±1.5% Typical, ±2.0% Maximum	
	Temperature Effect	±0.5% Typical, ±1.0% Maximum	-10° to 40°C
	Combined Effect	±1.6% Typical, ±3.2% Maximum	Source, Load and Temperature
Time Effect	0.2% Typical, 0.5% Maximum	(8 hours at 25°C)	
Start-up Time	300 msec Typical, 450 msec Maximum	100V a-c	
	250 msec Typical, 400 msec Maximum	200V a-c	

TABLE 3. POWER SUPPLY RATINGS AND SPECIFICATIONS (CONTINUED)

CHARACTERISTIC	SPECIFICATION	CONDITION/NOTES
Output Hold-up Time	10 msec Typical, 7 msec Minimum.	100V a-c
	10 msec Typical, 7 msec Minimum.	200V a-c
Overvoltage Protection	When the Power Supply goes into an overvoltage condition, the output is cut OFF. See PAR. 3.7.1.	
Low Voltage Protection	If output falls to 60% of rated output (5V for 36V model) for approximately 30 Seconds and overcurrent is triggered, the output is cut OFF. See PAR. 3.7.4.	
Remote Control ON/OFF:	±RC pins control on/off as follows: "High", 2.4V to 24V (or open), unit OFF- Fan Off; "Low", 0.0V to 0.4V (or closed), unit ON. Source current: 1.6mA maximum at low level Sink current: 1.0 mA maximum at high level.	Must be enabled by DIP switch positions 3 and 4 (see PAR. 3.6).
Meter (M suffix only) displays voltage or current; front panel switch-selectable	Voltmeter Accuracy: ±3% Ammeter Accuracy: ±5% for loads between 10%-100%	Voltmeter reads voltage at test points (will differ from voltage at load depending on load cable length). Ammeter accuracy degrades significantly for loads less than 10%
Operating Temperature:	-10 to 40°C	(see Figure 2.)
Startup Temperature	-10 to -20°C	(see Figure 2.)
Storage Temperature:	-30°C to +75°C	
Withstanding voltage : (at 15-35°C ambient, 10-85% relative humidity)	2000Va-c for 1 minute. Cutout current is 20mA	Between input and ground
	500Va-c for 1 minute. Cutout current is 100mA	Between output and ground
	3000Va-c for 1 minute. Cutout current is 20mA	Between input and output terminal
Insulation Resistance: (at 25°C, 65% relative humidity)	100 Megohms minimum (500Vdc)	Between output and ground, input and ground, and input and output,
Humidity:	10% to 95% relative humidity, noncondensing, Wet Bulb temperature <35°C	operating and non-operating
Vibration:	5-10 Hz., 10mm amplitude, 10-55 Hz., acceleration 64.3ft./s ² (19.6M/s ²) (2g)	non-operating 1 hr. on each of 3 axes, sweep time 10 minutes
Shock:	Acceleration: 643.5ft./s ² (196.1M/s ²) (20g), Pulse Duration: 11ms ± 5 msec	(non-operating, 1/2 sine pulse, three shocks on each axis, Power Supply is fixed on its bottom side)
Safety:	UL 60950-1, 1st Edition, 2007-10-31; CSA C22.2 No. 60950-1-03, 1st Edition, 2006-07; EN 60950.	
RoHS Compliance	RoHS versions available; contact Kepco Sales for further information.	
EMC Emission - Conducted:	Designed to meet FCC Class B, VCCI-Class B, EN55011-B, EN55022-B	
EMC Emission - Radiated:	Designed to meet FCC Class B, VCCI-Class B, EN55011-B, EN55022-B	
EMC Emission - Input harmonics current:	Designed to meet EN61000-3-2	
EMC Immunity	Designed to meet EN61000-6-2	
EMC Radiated susceptibility:	EN61000-4-3 level 3	normal operation
EMC Conducted susceptibility:	EN61000-4-6 level 3	normal operation
ESD:	EN61000-4-2, level 4	normal operation
Electrical fast transient burst:	EN61000-4-4 level 3	normal operation
Surge withstand:	EN61000-4-5, level 4	No damage
Power Frequency Magnetic Field:	EN61000-4-8, level 4	normal operation
Voltage dips interruptions and variations	EN61000-4-11	normal operation
Dimensions:	5.22 in. (132.5 mm) x 4.288 in. (108.9 mm) x 16.86 in. (428.2 mm) (See Figure 3)	
Mounting:	Plug-in	
Cooling:	Forced air flow - fan	
Frame Material/Cover Material:	Steel	
Weight	9 lbs, 4.1Kgs. maximum	

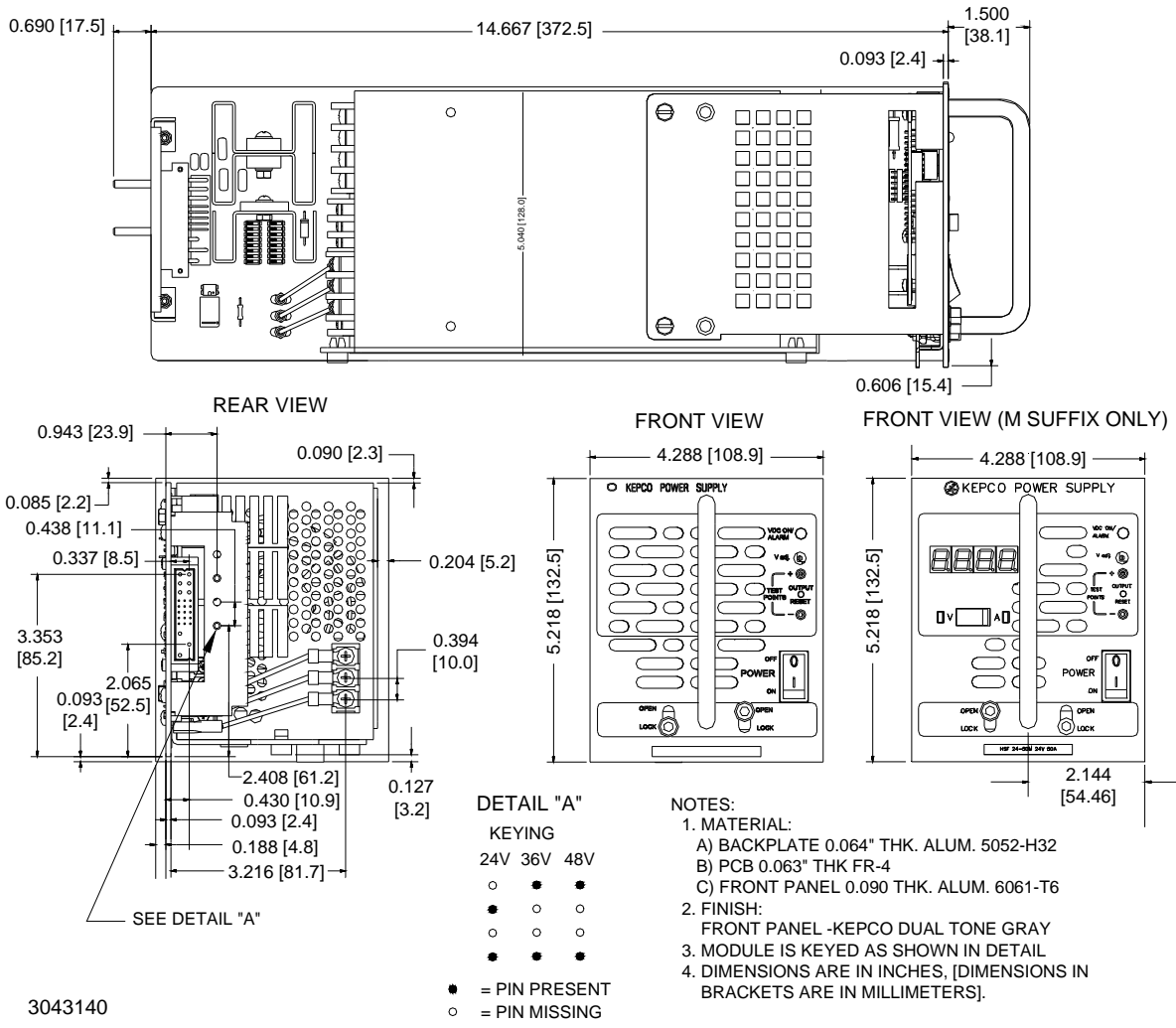

FIGURE 3. MECHANICAL OUTLINE DRAWING OF HSF 1200W/1500W POWER SUPPLY

3. FEATURES

3.1 DIP SWITCH CONFIGURATION

The power supply incorporates two DIP switches, SW1 and SW2 (see Figure 4), which must be configured before the unit is installed in the rack adapter. The DIP switches control the following parameters:

- Positions 1, 2, and 7 allow the output to be controlled either by the front panel Vadj control (see PAR. 3.4.1) or by remote control using either an external trimpot or voltage source (see PAR. 3.4.2). These positions can also be configured to allow a master/slave combination to be controlled either by the front panel Vadj control or by remote control using either an external trimpot or voltage source (see PAR 3.4)
- Positions 3 and 4 either allow the front panel reset button to be used to reset the unit after a fault or allow Remote on-off via mechanical switch or logic level (see PAR. 3.6) -
- Positions 5 and 6 allows alarm signals to be produced from either internal relay, Form C contacts (one NO, one NC) or open-collector logical alarm signals (see PAR. 3.8.2).

- Position 8 of SW1 either disables (default) or enables the visual alarm indication (see PAR. 3.8.1).

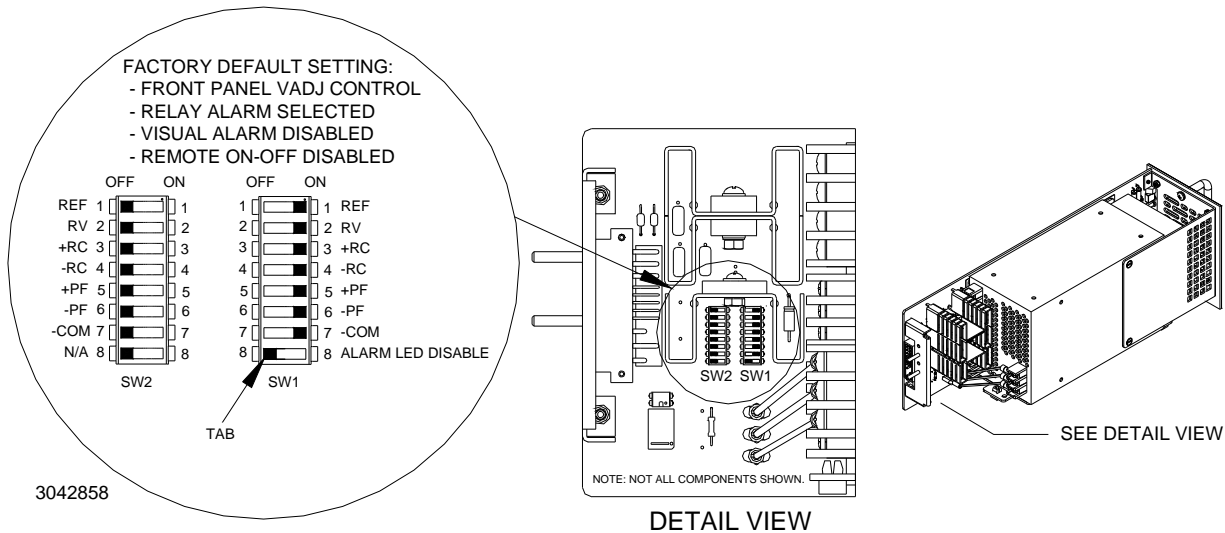

FIGURE 4. DIP SWITCH CONFIGURATION

3.2 FRONT PANEL ACCESS.

The front panel provides a power ON/OFF switch controlling input power and a "VDC ON" indicator which lights green when the unit is operating. If the unit is connected in a parallel configuration, the indicator lights red if the unit shuts off automatically, or the POWER switch is set to OFF.

CAUTION: DO NOT repeatedly toggle the power ON/OFF switch as this may cause unit to fault.

NOTE: The ON/OFF switch must be set to OFF before removing unit from rack adapter.

If remote on-off is not enabled (see PAR. 3.6), the OUTPUT RESET button restores output power in the event that overcurrent or overvoltage protection has tripped, or thermal overload or fan malfunction has occurred.

If remote voltage control (see PAR. 3.4.2) is not enabled, the front panel Vadj trimmer (see PAR. 3.4.1) provides adjustment of the output voltage within the limits specified in Table 1; test points are available at the front panel for monitoring the DC output.

Figure 5 shows the location of all operating controls, indicators and test points followed by an explanation of each.

3.3 KEYING

Keying of the power supply is established at the factory. The output voltage determines which key pins are installed (see Figure 3, Detail A). When the proper holes in the rack adapter are blocked by keying screws installed by the user, only a power supply of the correct voltage can be inserted in the rack adapter slot. Refer to the RA 19-4C Manual for rack adapter keying instructions.

- VDC ON/ALARM indicator. Lights green when unit is operating. When enabled by DIP switch configuration, lights red to indicate loss of output voltage in parallel configuration only (see PAR. 3.8.1).
- V.ADJ Output voltage adjustment trimmer: Adjusts output voltage within limits specified in Table 2 (see PAR. 3.4.1). Not functional if remote voltage control is enabled (see PAR. 3.4.2).
- DC output test points (+, -): Connect to voltmeter to monitor output voltage.

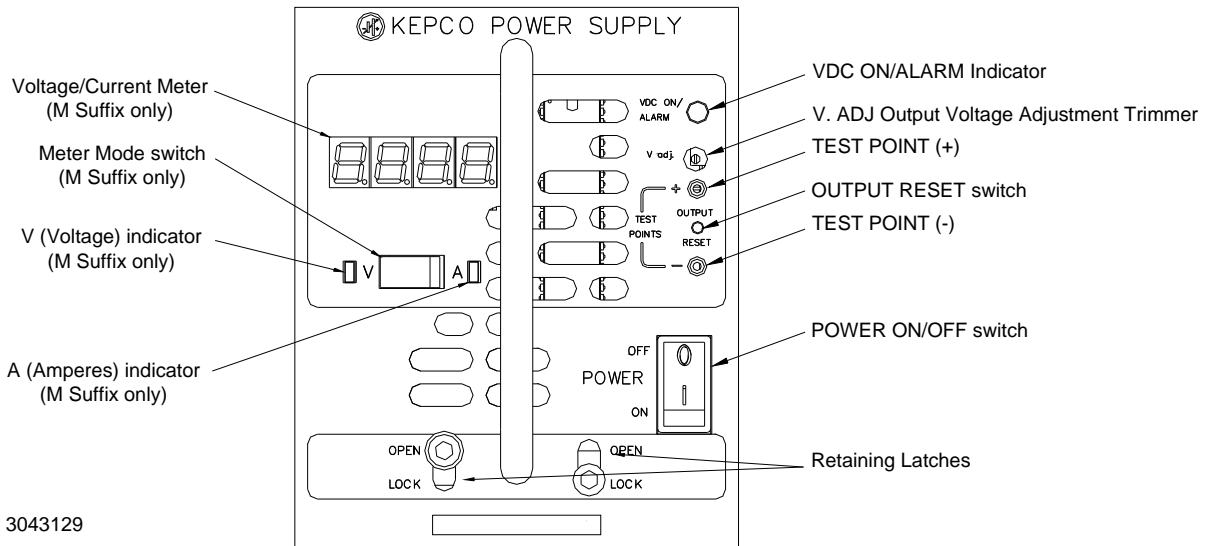

- OUTPUT RESET switch. Used to recycle power in the event of an alarm condition (see PAR. 3.7). Not functional when remote on/off control is enabled (see PAR. 3.6).
- POWER ON/OFF switch. Applies power to the unit. **CAUTION: Power must be OFF before unit is removed from the rack adapter.**
- Retaining Latches (2). Prevents inadvertent removal of unit from rack adapter (see PAR. 3.9)
- (M Suffix only) Voltage/Current meter: Monitors output voltage or current according to setting of Meter Mode switch. NOTE: Voltage displayed may differ from voltage at the load depending on lead length.
- (M Suffix only) Meter Mode slide switch: Set to V for display to show output voltage, set to A to show output current.
- (M Suffix only) V indicator: Lights green to indicate meter is showing Volts.
- (M Suffix only) A indicator: Lights amber to indicate meter is showing Amperes.

FIGURE 5. FRONT PANEL CONTROLS, INDICATORS AND TEST POINTS

3.4 OUTPUT VOLTAGE CONTROL

Output Voltage can be controlled from either the front panel (PAR. 3.4.1) or externally using a trimpot or voltage source (PAR. 3.4.2).

3.4.1 FRONT PANEL VOLTAGE CONTROL

Output voltage can be manually adjusted with the voltage adjustment control, V_{adj} (see Figure 5 for location) when DIP switches SW1 and SW2 (see Figure 4 for location) are configured as shown in Figure 6A (factory default) To adjust voltage, first place the unit under an operating load. Then monitor the (+) and (-) test points on the front panel with a precision voltmeter and turn the voltage control to the desired operating value. Refer to Table 1 for the recommended Adjustment Range.

3.4.2 REMOTE VOLTAGE CONTROL

For remote voltage control, set positions 1, 2 and 7 as shown in Figure 6B. This removes control from the front panel V_{adj} control and allows the output voltage to be adjusted by either an external trimmer pot (resistance) or by an external variable voltage source connected across the rack adapter I/O connector pin 12 (RV, Remote Voltage) and pin 10 (-COM, Common) as shown in Figure 7. At the rack adapter I/O connector use a shielded wire 6.6 feet (2M) maximum in length,

for connection of REF (pin 2), RV (pin 12), and –COM (pin 10) to the trimmer control or external voltage source.

NOTE: If remote voltage control is not implemented, the factory default for positions 1, 2 and 7 of DIP switches SW1 and SW2 must be restored (Figure 6A).

It is possible that the overvoltage protection may be triggered if the output voltage is decreased to a low level very quickly when the power supply is at a low load condition.

RESISTANCE: Connect the external trimmer as shown in Figure 7A. Suggested value for the trimmer control is 5K ohms. Referring to Figure 7 (A), R = 7.5K Ohms (M suffix: R = 5.6K Ohms) provides an output voltage adjustment range of from 70 to 130%. for the 24V model. R = 560 Ohms provides an output voltage adjustment range of from 17 to 150%. for the 36V model. R = 10K Ohms (M suffix: R = 7.5K Ohms) provides an output voltage adjustment range of from 70 to 115% for the 48V model.

VOLTAGE. By adjusting an external 3.5 to 6.5V voltage source, the 24V model can be adjusted from 70 to 130% of the nominal output. By adjusting an external 0 to 5.75V voltage source, the 36V model can be adjusted from 17 to 150% of the nominal output. By adjusting an external 3.5 to 5.75V voltage source, the 48V model can be adjusted from 70 to 115% of the nominal output. To ensure proper operation of the alarm relay, meter (M suffix only) and LED indicators, do not adjust external voltage below minimum listed in Table 4. Connect the voltage source across the RV and –COM pins as shown in Figure 7B.

TABLE 4. MINIMUM CONDITIONS FOR RELAY, METER AND LED OPERATION

MODEL	HSF 24-27	HSF 36-42	HSF 48-32
Minimum HSF output voltage required for relay, meter and LED functioning (Volts d-c) ¹	17	11	35
Minimum resistance of Limit resistor R (Figure 7A) in series with 5K ohm Trimpot to ensure proper operation of LEDs, meter and relay (Ohms) ¹	7.5K	560	10K
Minimum external voltage (Figure 7B) to ensure proper operation of LEDs, meter and relay. (Volts d-c) ¹	3.7	0.68	3.8

¹ - If operating below minimums listed, see PAR. 3.8.2.2 to implement ±PF alarm signals to monitor power supply status.

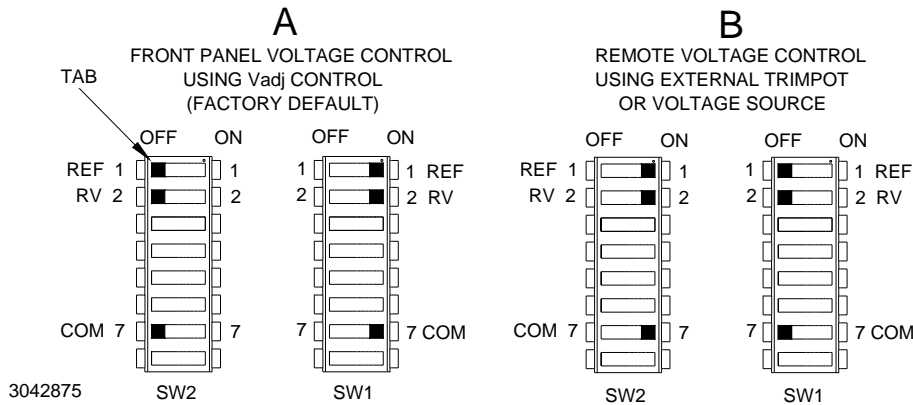

FIGURE 6. DIP SWITCH SETTINGS FOR CONTROL OF OUTPUT VOLTAGE

3.5 CURRENT MONITOR (C AND M SUFFIX ONLY)

Current monitor is via ±IMON assigned to pins of the RA 19-4C I/O connector (see Figure 1). Monitored Output Current (Amps) = Voltage drop across Rs (Volts) x Rs (Ohms), where voltage drop across Rs (see Table 2) is measured across ± IMON pins (requires millivoltmeter, range 0 to 200mV). Accuracy is ±3%; contact Kepco if greater accuracy is required. There is no isolation between ±IMON, alarm circuit and d-c output.

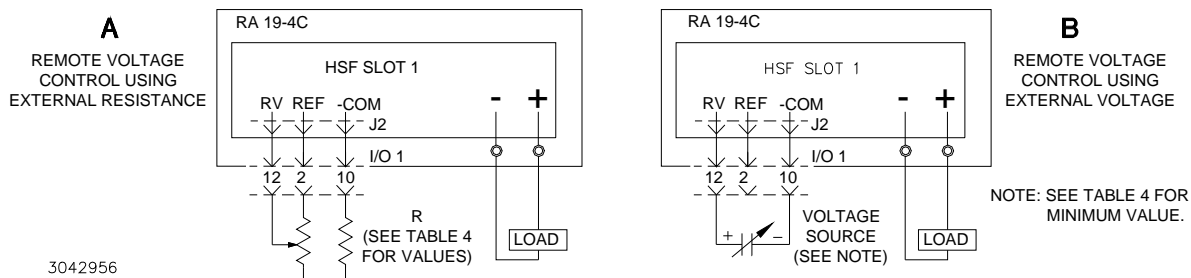

FIGURE 7. CONNECTIONS FOR REMOTE VOLTAGE CONTROL

3.6 REMOTE ON-OFF

When power is ON at the source, the output may be turned ON or OFF using the \pm RC signals if the remote ON-OFF feature is enabled. Note that when remote ON-OFF is enabled, the RESET OUTPUT switch does not function. Remote ON-OFF is enabled by setting DIP switch positions 3 and 4 as shown in Figure 8B. The +RC and -RC signals (at the rack adapter I/O connector, pins 15 and 8, respectively) then turn the unit on or off. These pins accept a logic level (2.4V to 24V “high” and 0.0 to 0.4V “low”), or a contact closure. When the \pm RC pins are open, using either a mechanical switch or a high level logic signal, the power supply output is cut OFF. When the \pm RC pins are shorted, the output returns to within specifications. At low level logic, the maximum source current is 1.6mA and at high level the sink current is 1.0mA. Positions 3 and 4 of both DIP switches must be restored to the factory default setting (Figure 8A) if remote ON-OFF is not used. The \pm RC pins are isolated from DC output pins.

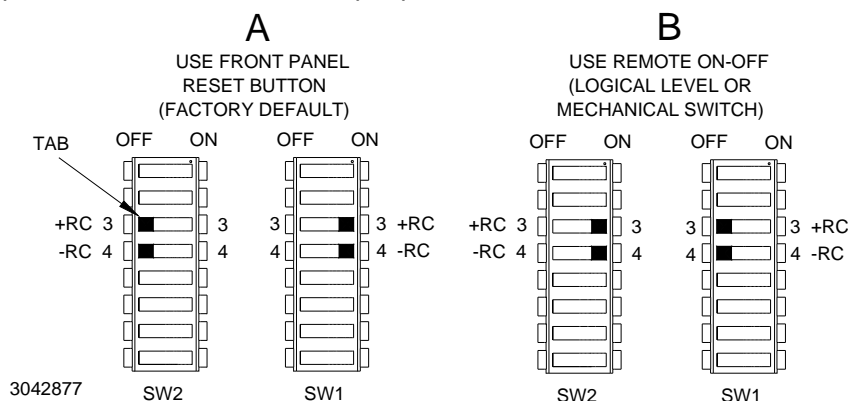

FIGURE 8. DIP SWITCH SETTINGS FOR USING RESET BUTTON OR REMOTE ON-OFF

3.7 PROTECTION CIRCUITS

The following protection features are implemented in the power supplies: overvoltage and over-temperature (PAR. 3.7.1), overcurrent (PAR. 3.7.2), fan failure (PAR. 3.7.3), and undervoltage (PAR. 3.7.4). The power supply provides a configurable visual alarm (see PAR. 3.8.1) as well as an option to use either relay contacts or logic levels for alarm signals (see PAR. 3.8.2)

3.7.1 OVERVOLTAGE AND OVERTEMPERATURE PROTECTION

When the output voltage of the power supply increases beyond the specified values (see Table 2), the output is cut OFF and the fan turns OFF. To restart (reset) the unit, press and release the OUTPUT RESET switch on the front panel or, if the remote on/off feature is in use (see PAR. 3.6), open connection between the RC pins and then reconnect the pins. The unit may also be restarted by turning the POWER ON/OFF switch to OFF, waiting 30 seconds, then setting the POWER switch to ON.

When the internal temperature of the power supply increases beyond safe values, the output is cut OFF and the fans turn OFF. The restart cycle (Power ON) should not begin until the temperature returns to within specifications. To restart (reset) the unit, set the POWER ON/OFF switch to OFF, wait 30 seconds, then set the POWER switch to ON. The power supply cannot be reset using the remote ON-OFF feature unless the power supply remains shut down for at least 30 seconds.

3.7.2 OVERCURRENT/CURRENT LIMIT SETTING AND PROTECTION

From 170 to 265V a-c input, the output characteristic of the power supply is a square type, and the unit is set to produce an alarm (see PAR. 3.8.2) and shut down if output current exceeds specifications (see Table 2) for more than 30 seconds and undervoltage detection is present (see PAR. 3.7.4). From 85 to 170V a-c input, operation (including alarm signals) is intermittent when current limit condition occurs. To restart (reset) the unit, remove AC input power, wait 30 seconds, then reconnect AC input power, or open the RC terminals and then reclose the terminals.

3.7.3 FAN FAILURE

A cutoff of the fan supply voltage causes the output to shut down and the fans to turn OFF. Fan failure and all the other protection circuit operations produce an alarm (see PAR. 3.8.2). To restart (reset) the unit, press and release the OUTPUT RESET switch on the front panel or, if the remote on/off feature is in use (see PAR. 3.6), open the connection between the \pm RC pins and then reconnect the pins. The unit may also be restarted by turning the POWER ON/OFF switch to OFF, waiting 30 seconds, then setting the POWER switch to ON. If fan rotation is out of specification the power supply will not recover.

3.7.4 UNDERVOLTAGE

If the output voltage of the power supply falls below 60 percent of the rated voltage for 30 seconds (5V for the 36V model) while overcurrent is detected, the unit turns off and an alarm occurs (either from the internal relay or optically-coupled alarm circuit, see PAR. 3.8.2). To restart (reset) the unit, press and release the OUTPUT RESET switch on the front panel or, if the remote on/off feature is in use (see PAR. 3.6), open the connection between the RC pins and then reconnect the pins. The unit may also be restarted by turning the POWER ON/OFF switch to OFF, waiting 30 seconds, then setting the POWER switch to ON.

3.8 ALARM SETTINGS

3.8.1 VISUAL ALARM.

When the unit is connected in a parallel configuration, the front panel VDC ON/ALARM indicator can be configured to light red if the respective power supply output voltage is lost or if the POWER switch is set to OFF. This is enabled when DIP switch 1, position 8 set to ON. This can be useful to indicate the loss of output voltage from one parallel-connected power supply that may not be readily apparent. The visual alarm is normally disabled: DIP switch SW1, position 8 set to OFF (factory default).

3.8.2 ALARM SIGNALS.

Either of two options are available for signalling alarms: isolated relay contacts (factory default, PAR. 3.8.2.1) or logic level alarm signals \pm PF (PAR. 3.8.2.2).

3.8.2.1 INTERNAL ISOLATED RELAY ALARM

The first option, the factory default setting, uses an isolated internal relay offering normally closed (NC) and normally open (NO) contacts referenced to an isolated common (AL COM). These contacts may be used to configure "close on failure" or "open on failure" alarm circuits. (Refer to the Series RA 19-4C Manual for alarm configurations for multiple HSF power supplies.) Setting positions 5 and 6 of the DIP switches as shown in Figure 9A selects this option. The NC (pin 6 of the rack adapter I/O connector) and NO (pin 7) signals are referenced to Alarm common (pin 14).

3.8.2.2 OPTICALLY-COUPLED LOGICAL ALARM

The second option uses optically-coupled logic level alarm signals (see PAR. 3.8.2.2), +PF (pin 5 of the rack adapter I/O connector) and -PF (pin 13), provided directly from the Kepco RKE power supply that is the heart of the HSF power supply. This option is selected by setting positions 5 and 6 of the DIP switches as shown in Figure 9B. Use this option if the power supply will operate below the minimum voltages specified in Table 4.

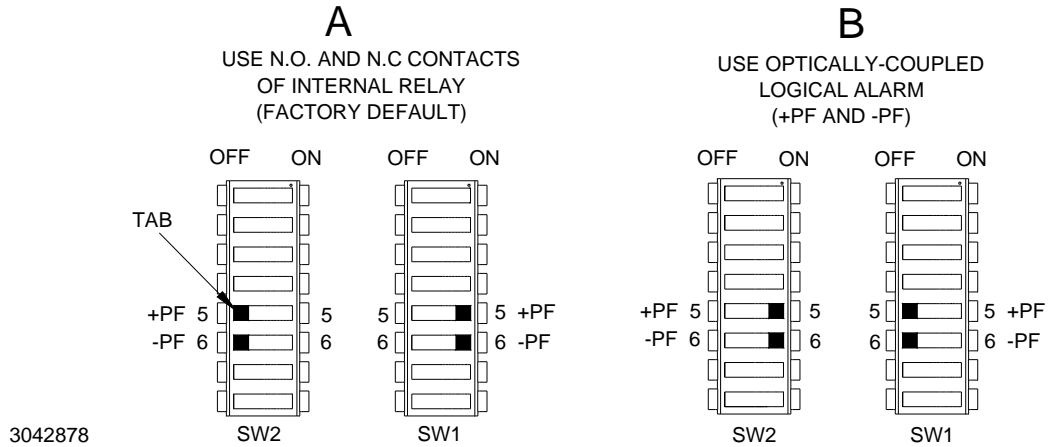

FIGURE 9. DIP SWITCH SETTINGS FOR OPTICALLY COUPLED LOGICAL ALARM

The logic alarm circuit is a diode transistor optical coupler (see Figure 10). The transistor is normally conducting. When the alarm is activated upon detection of power loss, overvoltage, fan fault, overtemperature or overcurrent condition, the transistor cuts off and the collector emitter circuit is open. Figure 11 is a timing diagram of the power fail signal.

The default state of the alarm is logic low. The sink current for the optocoupler is 50mA maximum, the maximum collector to emitter saturation voltage is 0.40 Volts, and the collector to emitter voltage is 40 volts maximum. The PF signals are isolated from the AC input and DC output.

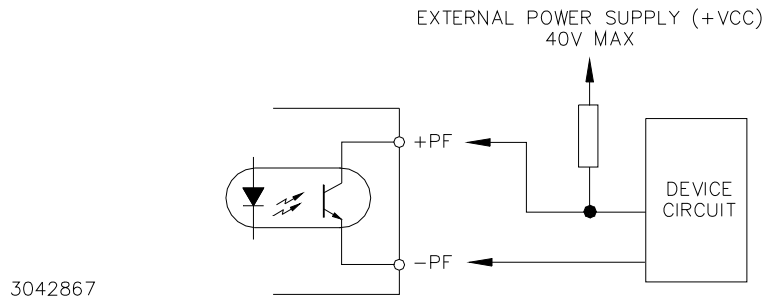

FIGURE 10. OUTPUT ALARM CIRCUIT OPTICALLY ISOLATED

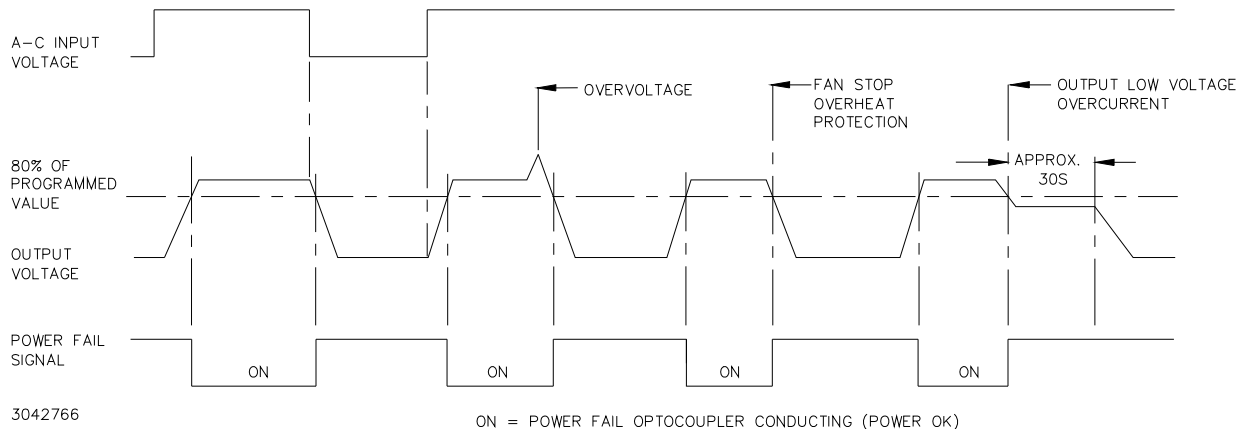

FIGURE 11. ±PF POWER FAILURE OPTOCOUPLER TIMING DIAGRAM

3.9 RETAINING LATCHES

HSF 1200W/1500W series power supplies are provided with (2) retention latches located at each side of the bottom edge of the front panel (see Figure 5). These latches work in conjunction with the RA 19-4C rack adapters to prevent unauthorized or inadvertent module extraction from an operating power system. The latch is engaged by loosening the cap-head screw approximately 1/2 turn CCW (use 5/32" hex key) and sliding the latch down to the bottom of the slot, then retightening the cap-head screw CW until snug. **DO NOT OVERTIGHTEN!** To release, follow the same procedure, except lift the latch to the top of the slot. Be sure to move the latch completely up or down to ensure full engagement and disengagement of the latching mechanism. When the HSP power supply is not installed in its plug-in rack adapter, it is recommended that the latch be secured in the open (up) position to prevent damage.

NOTE: Retaining latches must *not* be used to secure the HSF power supply in the rack adapter for shipping purposes.

4. LOAD CONNECTION

Connect the load to (+) and (-) terminals at the rear panel of the Rack Adapter. See Figure 12 for the proper way to connect multiple loads.

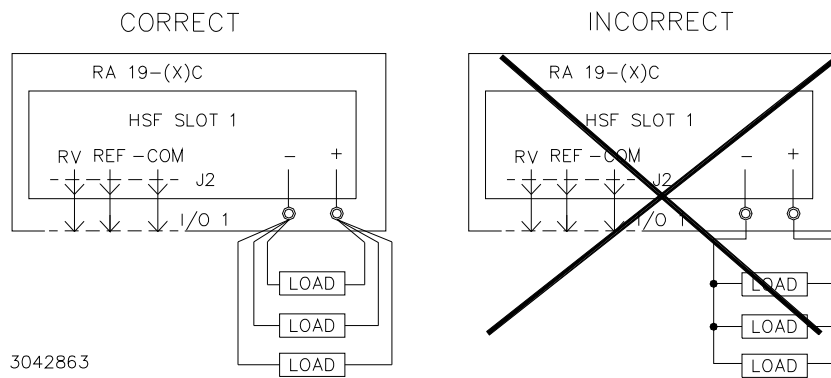

FIGURE 12. CORRECT AND INCORRECT METHODS OF LOAD CONNECTION

5. CONNECTING MULTIPLE POWER SUPPLIES

All connections to multiple HSF power supplies must be made via the I/O mating connectors at rear of the Rack Adapter or by the Rack Adapter DIP switches. These connections, including the configuration of the two internal HSF DIP switches, are described in the Rack Adapter Instruction manual, and include:

- Using one power supply to control the output of multiple supplies.
- Using parallel master/slave configurations (for increased current or redundancy) where the user either predetermines the master or allows the load to determine which is the master. These configurations also cover the use of the Current Balancing feature of the power supply. NOTE: Requires minimum of 10% load to operate properly.
- Using series configurations (for increased voltage).
- Using open-on-fail or close-on-fail alarm schemes with multiple power supplies.