

INSTRUCTION MANUAL



KEPCO An ISO 9001 Company.

**KIT
DIN RTW
-300S**

DIN-RAIL MOUNTING KIT FOR SERIES RTW 300W

DESCRIPTION. Kepco KIT, Model DIN RTW-300S contains a preassembled mounting bracket with left and right mounting clips, and associated hardware (see Table 1) used to install RTW Series 300W power supplies on a DIN rail. The "S" suffix is for mounting along the short dimension (width) as shown in Figure 1. Outline dimensions are shown in Figure 4.

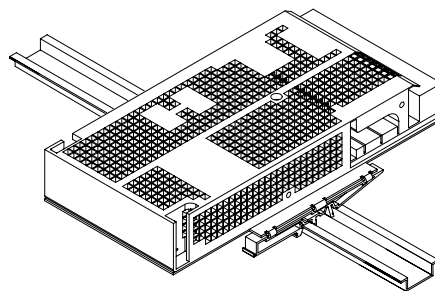

FIGURE 1. S SUFFIX ORIENTATION

TABLE 1. COMPONENTS SUPPLIED

KIT MODEL NO.	CLIP (QTY 2) PART NO.	BRACKET (QTY 1) PART NO.	SCREW (QTY 3) PART NO.
DIN RTW-300S	108-0362	128-2293	101-0463 (M4 x 8MM ST., PHPH)
NOTE: Clips are supplied preassembled on mounting bracket. To replace a mounting clip order the clip and bracket and assemble per Figure 3 detail.			

INSTALLATION

- INSTALL MOUNTING BRACKET WITH CLIPS.** Attach mounting bracket to power supply using hardware supplied (see Figure 3).

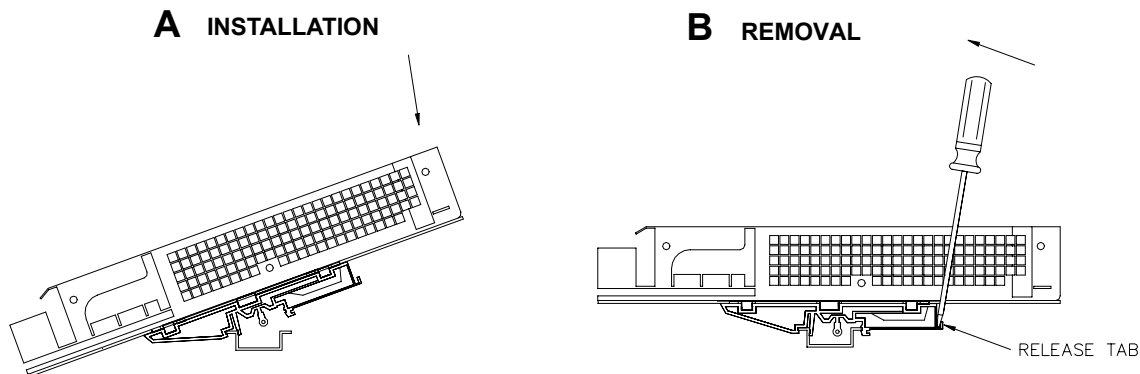

FIGURE 2. INSTALLATION AND REMOVAL OF POWER SUPPLY FROM DIN RAIL

- INSTALL POWER SUPPLY ON DIN RAIL.** To mount the power supply on the rail insert one end of both clips under one edge of the rail, then snap the other end of the two clips into place (see Figure 2A).

REMOVING POWER SUPPLY FROM DIN RAIL. With power off, disconnect wires from power supply. While grasping the power supply with one hand, insert a screwdriver in the area shown in Figure 2B and apply leverage towards the left as shown in Figure 2B to disengage each clip from the rail. Where mounting clips are close together, it may be necessary to apply leverage with two screwdrivers simultaneously.

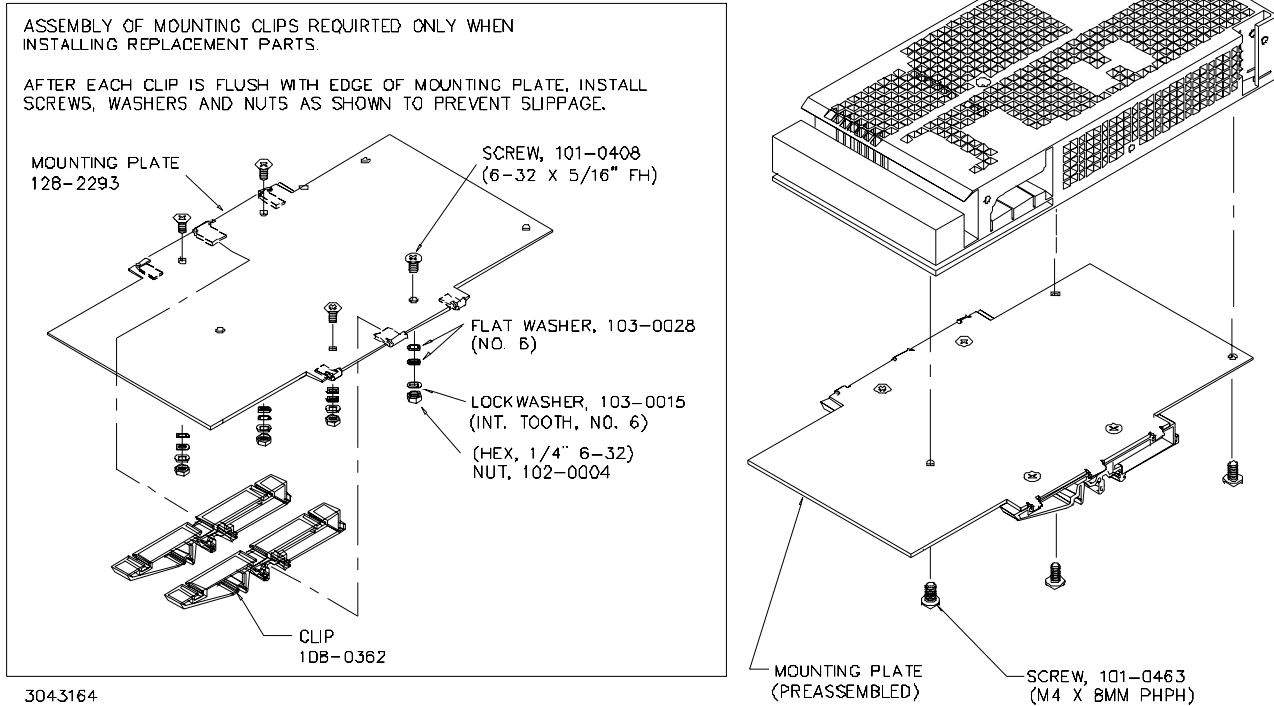

FIGURE 3. INSTALLING CLIPS ON POWER SUPPLY

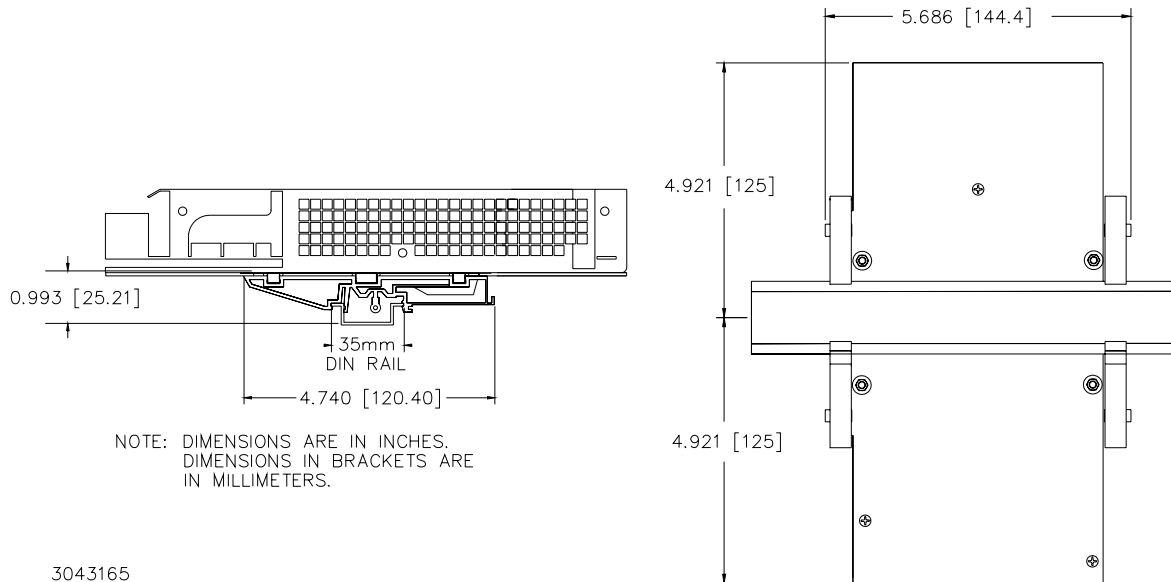

FIGURE 4. POWER SUPPLY WITH KIT INSTALLED, OUTLINE DIMENSIONS