

# OPERATOR'S MANUAL

## HSF 300W, M and MZ Models POWER SUPPLY

**SINGLE OUTPUT METERED POWER SUPPLIES  
SINGLE PHASE, POWER FACTOR CORRECTED  
UNIVERSAL AC INPUT**

KEPCO INC.  
An ISO 9001 Company.

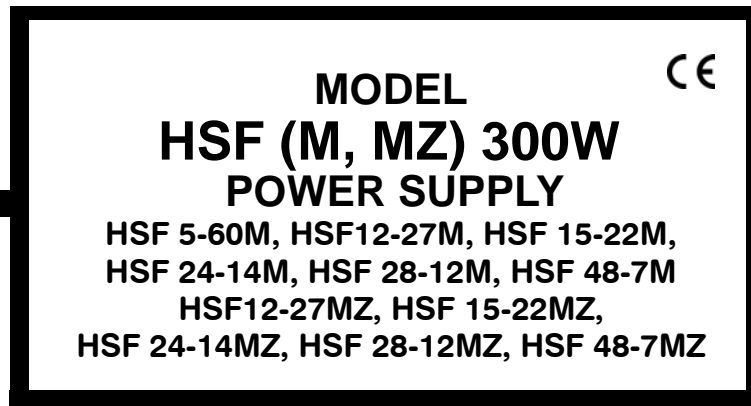

### IMPORTANT NOTES:

- 1) This manual is valid for the following Model and associated serial numbers:

MODEL	SERIAL NO.	REV. NO.
HSF 300W		

- 2) A Change Page may be included at the end of the manual. All applicable changes and revision number changes are documented with reference to the equipment serial numbers. Before using this Instruction Manual, check your equipment serial number to identify your model. If in doubt, contact your nearest Kepco Representative, or the Kepco Documentation Office in New York, (718) 461-7000, requesting the correct revision for your particular model and serial number.
- 3) The contents of this manual are protected by copyright. Reproduction of any part can be made only with the specific written permission of Kepco, Inc.

Data subject to change without notice.

©2016, KEPCO, INC  
P/N 228-1697-r5



KEPCO, INC. • 131-38 SANFORD AVENUE • FLUSHING, NY. 11355 U.S.A. • TEL (718) 461-7000 • FAX (718) 767-1102  
email: [hq@kepcopower.com](mailto:hq@kepcopower.com) • World Wide Web: <http://www.kepcopower.com>

# TABLE OF CONTENTS

SECTION	PAGE
1. Introduction.....	1
1.1 Scope of Manual .....	1
1.2 Description .....	1
2. Specifications .....	2
3. Features .....	6
3.1 DIP Switch Configuration .....	6
3.2 Front Panel Access .....	7
3.3 Keying .....	7
3.4 Output Voltage Control.....	8
3.4.1 Front Panel Voltage Control .....	8
3.4.2 Remote Voltage Control .....	8
3.4.3 VDC ON/Alarm Indicator Power Options.....	10
3.5 Remote On-Off .....	10
3.6 Reset (Restart) .....	11
3.7 Protection Circuits .....	11
3.7.1 Overvoltage And Overtemperature Protection .....	11
3.7.2 Overcurrent Setting and Protection .....	12
3.7.3 Fan Failure .....	12
3.7.4 Undervoltage .....	12
3.8 Alarm Settings .....	12
3.8.1 Visual Alarm .....	12
3.8.2 Alarm Signals .....	12
3.8.2.1 Internal Isolated Relay Alarm .....	12
3.8.2.2 Optically-Coupled Logical Alarm .....	13
3.9 Local/remote Sensing.....	14
3.10 Retaining Latches.....	14
4. Load Connection .....	14
5. Connecting Multiple Power Supplies.....	14
5.1 Adjusting the Voltage .....	15
5.2 Parallel Connections, M Models .....	15
5.3 Parallel Connections, MZ Models.....	15
5.3.1 Minimum Load .....	16
5.3.2 Voltage Set Restrictions .....	16

## LIST OF FIGURES

FIGURE	TITLE	PAGE
1	HSF Rear Panel Connector and RA 19-4C Rack Adapter I/O Connector .....	1
2	Power Rating Vs. Temperature .....	3
3	Mechanical Outline Drawing, HSF 300W M and MZ Models.....	6
4	DIP Switch Configuration.....	7
5	Front Panel Controls, Indicators and Test Points .....	8
6	DIP Switch Settings for Control of Output Voltage .....	9
7	Connections For Remote Voltage Control.....	10
8	DIP switch settings for VDC ON/ALARM Power Options .....	10
9	DIP Switch Settings for Using RESET button or Remote ON-OFF .....	11
10	DIP switch settings for Optically Coupled Logical Alarm .....	13
11	Output Alarm Circuit Optically Isolated.....	13
12	±PF Power Failure Optocoupler Timing Diagram.....	14

## LIST OF TABLES

TABLE	TITLE	PAGE
1	HSF Rear Connector Pin Assignments .....	2
2	Output Ratings and Specifications .....	3
3	Power Supply Ratings and Specifications .....	4
4	Minimum Conditions for Relay, Meter and LED Operation .....	9
5	Conditions for VDC ON/ALARM LED Operation Powered by Output .....	10

# 1. INTRODUCTION

## 1.1 SCOPE OF MANUAL

This Operator's Manual covers the installation and operation of the Kepco HSF 300W Series, Models M and MZ, of Metered Switching Power Supplies. For service information, write directly to: Kepco Inc., 131-38 Sanford Avenue, Flushing, New York, 11355, U.S.A. Please state Model Designation and Serial Number of your HSF Power Supply. This information can be found on the nameplate of the unit.

## 1.2 DESCRIPTION

The Kepco HSF 300 Watt Series M and MZ models are hot swappable, high frequency switching, plug-in power supplies that are completely interchangeable with the non-metered HSF Series. Six models may be selected for outputs of 5V, 12V, 15V, 24V, 28V or 48V. They employ forward conversion and power factor correction and are designed to operate in a fault tolerant power system with a nominal a-c input of 100V a-c to 240V a-c (input voltage range 85 to 265 Va-c), 50-60 Hz (input frequency range 47-440Hz). A built-in current balancing circuit and OR-ing diodes allow configuration for hot-swap and parallel-redundant N+1 operation.

**NOTE:** HSF 5-60M functions the same as MZ models. Throughout this manual, where there are differences between M and MZ models, refer to the MZ model information for HSF 5-60M.

The HSF M Models (except for HSF 5-60M) use the HSF output to power the VDC ON indicator, internal alarm relay, and the meter. A minimum HSF output voltage is needed to maintain functionality for these components.

The HSF MZ Models, as well as the HSF 5-60M, use an auxiliary internal power supply to power the internal relay and the meter, allowing the output voltage to be adjusted down to zero without affecting meter or alarm performance. The default configuration of MZ models uses an internal reference voltage to power the VDC ON indicator. An option is provided which allows the VDC ON indicator to be powered by the HSF output, requiring a minimum voltage to maintain functionality of the indicator.

These power supplies are designed to be used with Kepco's Series RA 19-4C rack adapters. The RA 19-4C rack adapter accepts up to four 300W modules. All input/output connections are through a 24-pin connector that plugs in to the rack adapter. All external connections described in the following paragraphs are made through the rack adapter's I/O connector (see Figure 1).

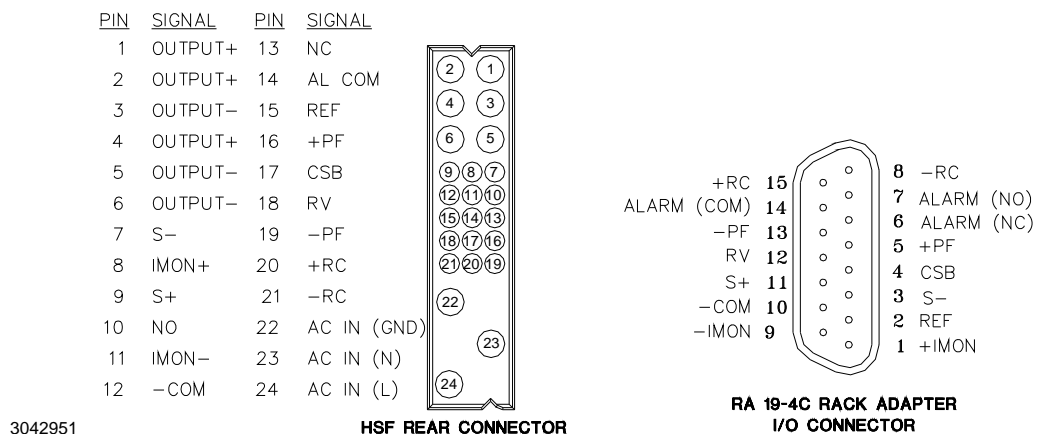

**FIGURE 1. HSF REAR PANEL CONNECTOR AND RA 19-4C RACK ADAPTER I/O CONNECTOR**

**TABLE 1. HSF REAR CONNECTOR PIN ASSIGNMENTS**

Signal Name	Pin	Function
Output +	1, 2, 4	DC output (+) applied to load.
Output –	3, 5, 6	DC Output (–) applied to load.
SENSE–	7	Sense– connection
IMON+	8	Current Monitor+ (sense resistor).
SENSE+	9	Sense+ connection
NO	10	Normally Open contact of alarm relay, referenced to AL COM, pin 14 (see PAR. 3.8.2.1).
IMON–	11	Current Monitor– (sense resistor).
–COM	12	–Signal Common provides return for REF, pin 15, and RV, pin 18, signals.
NC	13	Normally Closed contact of alarm relay, referenced to AL COM, pin 14 (see PAR. 3.8.2.1).
AL COM	14	Common contact of alarm relay (see PAR. 3.8.2.1).
REF	15	Reference voltage. When used with RV, pin 18, allows all output voltages of paralleled slave supplies to be controlled by one voltage adjustment of a master power supply. When REF is connected to RV via an external trimmer, the external trimmer determines output voltage (see PAR. 3.4.2). Connections are made via DIP switches (see PAR. 3.1).
+PF	16	+Power Fail of open-collector alarm circuit. Used with –PF, pin 19 (see PAR. 3.8.2.2).
CSB	17	Current Share Bus - Used whenever several power supplies are connected in parallel (see PAR. 5.).
RV	18	Remote Voltage - Used with REF, pin 15, for remotely controlling the output voltage (see PAR. 3.4.2)
–PF	19	–Power Fail of open-collector alarm circuit. Used with +PF, pin 16 (see PAR. 3.8.2.2).
+RC	20	+Remote On-off used with –RC, pin 21, to allow remote turn-on turn-off of the unit (see PAR. 3.4.3)
–RC	21	–Remote On-off used with +RC, pin 20, to allow remote turn-on turn-off of the unit (see PAR. 3.4.3)
GND	22	AC input ground
N	23	AC Input neutral
L	24	AC input line

## 2. SPECIFICATIONS

Table 2 contains specifications and operating limits of individual HSF 300W Series M and MZ models. Table 3 contains specifications and operating limits common to all HSF 300W Series M and MZ Models. These specifications are at nominal input voltages at 25°C unless otherwise specified.

**TABLE 2. OUTPUT RATINGS AND SPECIFICATIONS**

HSF MODEL		5-60*	12-27*	15-22*	24-14*	28-12*	48-7*	
Output Volts d-c (nominal)		5	12	15	24	28	48	
Output Adjustment Range <sup>(1)(2)</sup>	Using front panel trimpot (Volts d-c) <sup>(3)</sup>	M	0 to 5.5	5.5 to 13.8 <sup>(8)</sup>	7 to 17.4 <sup>(8)</sup>	7 to 28.2 <sup>(8)</sup>	7 to 33 <sup>(8)</sup>	7 to 52.2 <sup>(8)</sup>
		MZ <sup>(3)</sup>	0 to 5.5	0 to 13.8	0 to 17.4	0 to 28.2	0 to 33	0 to 52.2
	Using Voltage source or external 5K ohm trimpot <sup>(3)</sup> (Volts d-c)	0 to 5.5	0 to 13.8	0 to 17.4	0 to 28.2	0 to 33	0 to 52.2	
Output Current (nominal) (Amps)		60	27	22	14	12	7	
Maximum Output Power (Watts) <sup>(4)</sup>		300	300	300	300	300	300	
Overcurrent Setting (Amps) <sup>(5)</sup>		63-78	28.4-35.1	23.1-28.6	14.7-18.2	12.6-15.6	7.4-9.1	
Short Circuit Current (Amps)		82	35	29	20	17	11	
Overvoltage Protection (OVP) (Volts d-c) <sup>(6)</sup>		5.7 - 7.0	14.3 - 16.8	18.0 - 24.0	29.3 - 33.6	34.2 - 39.2	54.5 - 59.8	
Efficiency (% typ.)	AC Input 100V	72	74	75	78	78	79	
	AC Input 200V	78	78	79	82	82	83	
Power Factor (typ.)	AC Input 100V	0.99	0.99	0.99	0.99	0.99	0.99	
	AC Input 200V	0.95	0.95	0.95	0.95	0.95	0.95	
Ripple & Noise <sup>(7)</sup> (mV, p-p)	ripple	80	120	120	150	150	200	
	ripple noise	120	150	150	200	200	200	
Sense Resistor (IMON) values (Ohms)		0.002	0.01	0.01	0.02	0.05	0.02	

- \* Unless otherwise noted, specifications apply to both M and MZ models.
- M Models only:** To adjust output voltage down to approximately 0V use external voltage source or resistance (see PAR. 3.4.2). Refer to Table 4 for minimum conditions required to maintain proper operation of alarm relay, meter and visual LED indicator.
  - If the visual LED indicator is powered from the HSF output (see PAR 3.4.3), refer to Table 5 for minimum conditions required to maintain functionality of the indicator.
  - Using trimpot to attain voltages outside the specified adjustment range may trigger undervoltage (PAR 3.7.4) or overvoltage (PAR 3.7.1) faults. Recovery is by removing, and after approximately 40 seconds, reapplying AC input power or by reset (open and close) at  $\pm$ RC terminals (no delay).
  - See Figure 2 for power derating.
  - Square type. Output voltage returns automatically only if cause is removed within 30 seconds (see PAR. 3.7.2).
  - When overvoltage is detected, output is shut OFF. Recovery is by removing, and after approximately 40 seconds, reapplying AC input power or by reset (open and close) at  $\pm$ RC terminals (no delay).
  - Ripple and noise levels above are satisfied when conditions are 0 to 100% load, 0 to 40°C (load is derated from 40 to 55°C, see Figure 2), and bandwidth  $\leq$  100MHz.
  - Range shown is operating range; minimum range upon startup is 0.5V higher than minimum operating range shown.

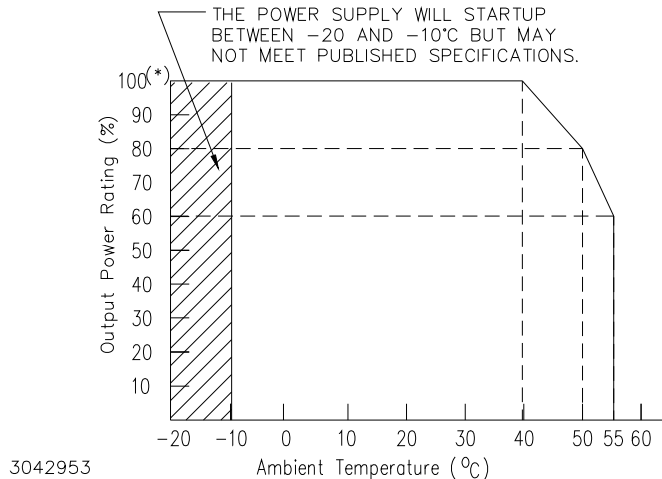

**FIGURE 2. POWER RATING VS. TEMPERATURE**

**TABLE 3. POWER SUPPLY RATINGS AND SPECIFICATIONS**

CHARACTERISTIC	SPECIFICATION	CONDITION/NOTES
Input Voltage	Nominal: 100-120V a-c, 200-240V a-c Range: 85-265V a-c, 110-370V d-c	0 to 100% load, -10 to 40°C
Input Source Frequency	Nominal: 50-60 Hz Range: 47-440 Hz	0 to 100% load, -10 to 40°C At 440 Hz leakage current exceeds UL/VDE safety spec. limit.
Input Current: (Maximum Load At 25°C with Nominal Output Voltage)	4.4A rms max.	100 - 120V a-c
	2.2A rms max.	200 - 240V a-c
Switching Frequency	140KHz typ.	Forward Converter
Input Protection	A limiting resistor in series with a resistor fuse (and thyristor circuit) reduces start-up surge. The internal power supply is protected against shorts by an input fuse. Fuse value 10.0A at 250 Volts	
Input Surge cold start, interval > 30 sec ( First surge only, not including current flow into EMI filter)	15A typ., 20A max. first surge	100 - 120V ac
	30A typ., 40 max. first surge	200- 240 V ac
Leakage Current:	0.24mA typ., 0.3mA max.	120V a-c, 60Hz per IEC 950 and UL1950
	0.31mA typ., 0.38mA max.	240V a-c, 60Hz per IEC 950 and UL1950
Power Factor	0.99 typical	Rated output, rated input
Transient Recovery excursion characteristic	±4% maximum	50% to 100% load, transient time >50µsec
	recovery time 1 ms maximum	
Stabilization		
Source Effect (min - max)	±0.1% Typical, ±0.2% Maximum	85 to 132V a-c, 170 to 265V a-c
Load Effect	±0.3% Typical, ±2% Maximum (default) ±0.3% Typical, ±0.6% Maximum (see PAR. 3.4)	Individual Mode: 0%-100% load change Current Sharing: 10%-100% load change
Temperature Effect	±0.5% Typical, ±1.0% Maximum	-10° to 40°C
Combined Effect	±0.9% Typical, ±1.8% Maximum	Source, Load and Temperature
Time Effect	0.2% Typical, 0.5% Maximum	1/2 to 8 hours at 25°C
Start-up Time	280 msec Typical, 350 msec Maximum	100V a-c
	150 msec Typical, 210 msec Maximum	240V a-c
Output Hold-up Time	30 msec Typical, 20 msec Minimum.	100V a-c
	40 msec Typical, 20 msec Minimum.	240V a-c
Overvoltage Protection	When the Power Supply goes into an overvoltage condition, the output is cut OFF. See PAR. 3.7.1.	
Remote Control ON/OFF:	±RC pins control on/off as follows: "High", 2.4V to 24V (or open), unit OFF- Fan Off; "Low", 0.0V to 0.4V (or closed), unit ON. Source current: 1.6mA maximum at low level Sink current: 1.0 mA maximum at high level.	Must be enabled by DIP switch positions 3 and 4 (see PAR. 3.4.3).
Meter (displays voltage or current; front panel switch-selectable)	Voltmeter Accuracy: ±3% Ammeter Accuracy: ±5% for loads between 10%-100%	Voltmeter reads sense lines; use remote sensing to display voltage at load. Ammeter accuracy degrades significantly for loads less than 10%
Operating Temperature:	-10 to 40°C	(see Figure 2.)
Startup Temperature	-10 to -20°C	(see Figure 2.)
Storage Temperature:	-30°C to +75°C	

**TABLE 3. POWER SUPPLY RATINGS AND SPECIFICATIONS (CONTINUED)**

CHARACTERISTIC	SPECIFICATION	CONDITION/NOTES
Withstanding voltage : (at 15-35°C ambient, 10-85% relative humidity)	2000Va-c for 1 minute. Cutout current is 20mA	Between input and ground
	500Va-c for 1 minute. Cutout current is 100mA	Between output and ground
	3000Va-c for 1 minute. Cutout current is 20mA	Between input and output terminal
Insulation Resistance: (at 25°C, 65% relative humidity)	100 Megohms minimum (500Vdc)	Between output and ground, input and ground, and input and output,
Humidity:	10% to 95% relative humidity, noncondensing, Wet Bulb temperature <35°C	operating and non-operating
Vibration:	5-10 Hz., 10mm amplitude, 10-55 Hz., acceleration 64.3ft./s <sup>2</sup> (19.6M/s <sup>2</sup> ) (2g)	non-operating 1 hr. on each of 3 axes, sweep time 10 minutes
Shock:	Acceleration: 643.5ft./s <sup>2</sup> (196.1M/s <sup>2</sup> ) (20g), Pulse Duration: 11ms ± 5 msec	(non-operating, 1/2 sine pulse, three shocks on each axis, Power Supply is fixed on its bottom side)
Safety:	Designed to meet UL: 60950; CSA:C22.2 60950; TUV: EN60950.	
RoHS Compliance	Contact Kepco Sales for further information.	
EMC Emission - Conducted:	Designed to meet FCC Class B, VCCI-Class B, EN55011-B, EN55022-B	
EMC Emission - Radiated:	Designed to meet FCC Class B, VCCI-Class B, EN55011-B, EN55022-B	
EMC Emission - Input harmonics current:	Designed to meet EN61000-3-2	
EMC Immunity	Designed to meet EN61000-6-2	
EMC Radiated susceptibility:	EN61000-4-3 level 3	normal operation
EMC Conducted susceptibility:	EN61000-4-6 level 3	normal operation
ESD:	EN61000-4-2, level 4 (HSF 5-60M: level 3)	normal operation
Electrical fast transient burst:	EN61000-4-4 level 3	normal operation
Surge withstand:	EN61000-4-5, level 4 (HSF 5-60M: level 3)	No damage
Power Frequency Magnetic Field:	EN61000-4-8, level 4 (HSF 5-60M: level 3)	normal operation
Voltage dips interruptions and variations	EN61000-4-11	normal operation
Dimensions:	5.22 in. (132.5 mm) x 4.288 in. (108.9 mm) x 16.86 in. (428.2 mm) (See Figure 3)	
Mounting:	Plug-in	
Cooling:	Forced air flow - fan	
Frame Material/Cover Material:	Steel	
Weight	8 lbs, 3.7Kgs. maximum	

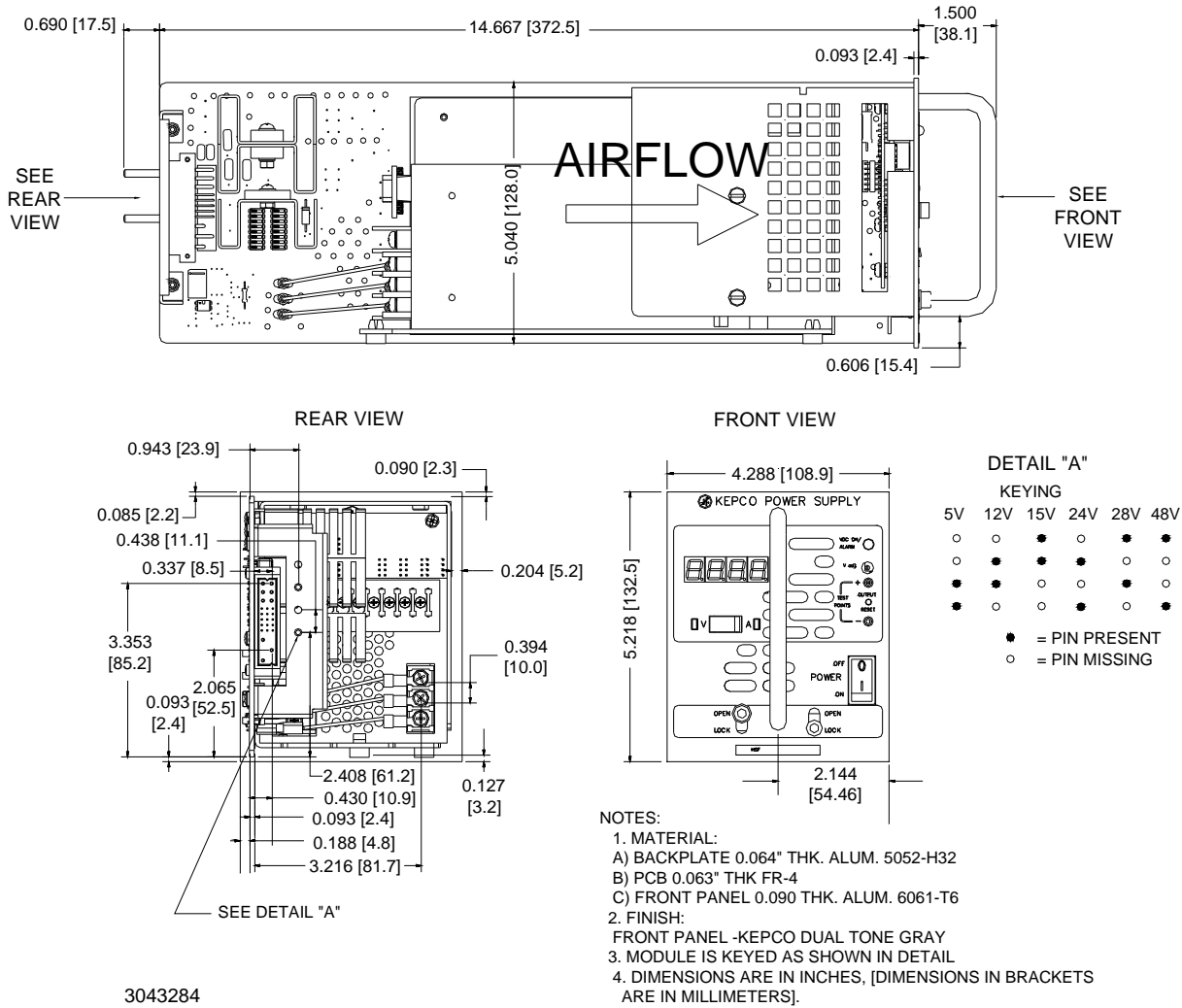

**FIGURE 3. MECHANICAL OUTLINE DRAWING, HSF 300W M AND MZ MODELS**

### 3. FEATURES

#### 3.1 DIP SWITCH CONFIGURATION

The HSF 600W Series M and MZ models incorporate two DIP switches, SW1 and SW2 (see Figure 4), which must be configured before the unit is installed in the rack adapter. The DIP switches control the following parameters:

- Positions 1, and 2 allow the output to be controlled either by the front panel Vadj control (see PAR. 3.4.1) or by remote control using either an external trimpot or voltage source (see PAR. 3.4.2). These positions can also be configured to allow a master/slave combination to be controlled either by the front panel Vadj control or by remote control using either an external trimpot or voltage source (see PAR 3.4).
- Positions 3 and 4 either allow the front panel reset button to be used to reset the unit after a fault or allow Remote on-off via mechanical switch or logic level (see PAR. 3.4.3).
- Positions 5 and 6 allows alarm signals to be produced from either internal relay, Form C contacts (one NO, one NC) or open-collector logical alarm signals (see PAR. 3.8.2).



- Position 7 of SW1 either enables (default) or disables using the auxiliary supply to power the DC ON indicator. Position 8 of SW2 either disables (default) or enables using the HSF output voltage to power the DC ON indicator; requires minimums per Table 4 if enabled (see PAR 3.9). Only one of these two must be enabled, the other disabled.
- Position 8 of SW1 either disables (default) or enables the visual alarm indication (see PAR. 3.8.1).

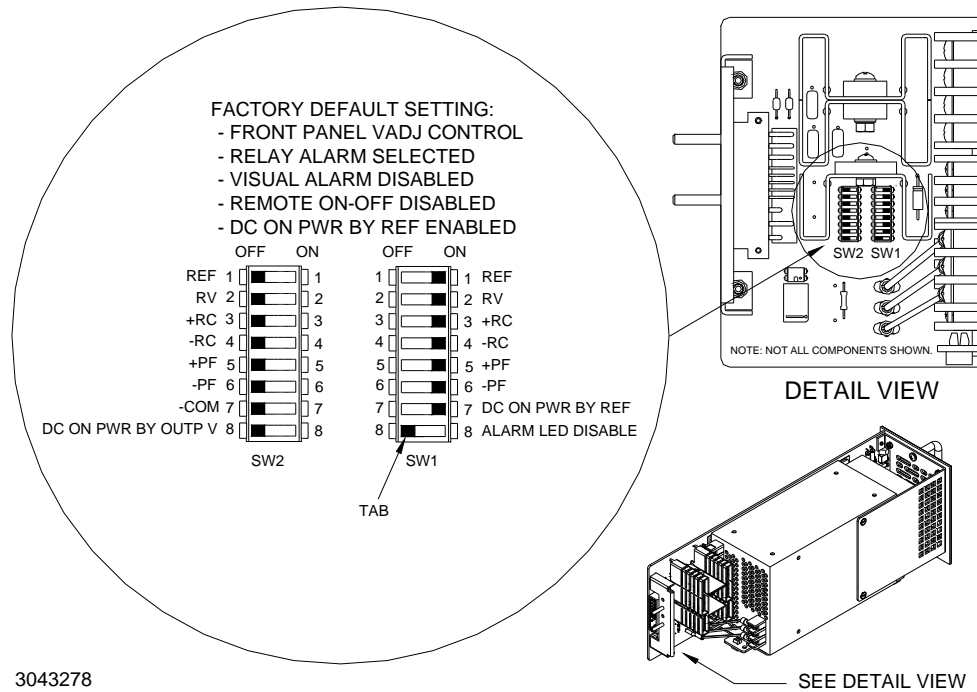

FIGURE 4. DIP SWITCH CONFIGURATION

### 3.2 FRONT PANEL ACCESS.

The front panel provides a power ON/OFF switch controlling input power and a "VDC ON" indicator which lights green when the unit is operating. If the unit is connected in a parallel configuration, the indicator lights red if the unit shuts off automatically, or the POWER switch is set to OFF.

**CAUTION: DO NOT repeatedly toggle the power ON/OFF switch as this may cause unit to fault.**

NOTE: The ON/OFF switch must be set to OFF before removing unit from rack adapter.

If remote on-off is not enabled (see PAR. 3.4.3), the OUTPUT RESET button restores output power in the event that overcurrent or overvoltage protection has tripped, or thermal overload or fan malfunction has occurred.

If remote voltage control (see PAR. 3.4.2) is not enabled, the front panel Vadj trimmer (see PAR. 3.4.1) provides adjustment of the output voltage within the limits specified in Table 2; test points are available at the front panel for monitoring the DC output.

Figure 5 shows the location of all operating controls, indicators and test points followed by an explanation of each.

### 3.3 KEYING

Keying of the HSF 300W is established at the factory. The output voltage determines which key pins are installed (see Figure 3, Detail A). When the proper holes in the rack adapter are blocked by keying screws installed by the user, only a power supply of the correct voltage can be inserted in the rack adapter slot. Refer to the RA 19-4C Manual for rack adapter keying instructions.

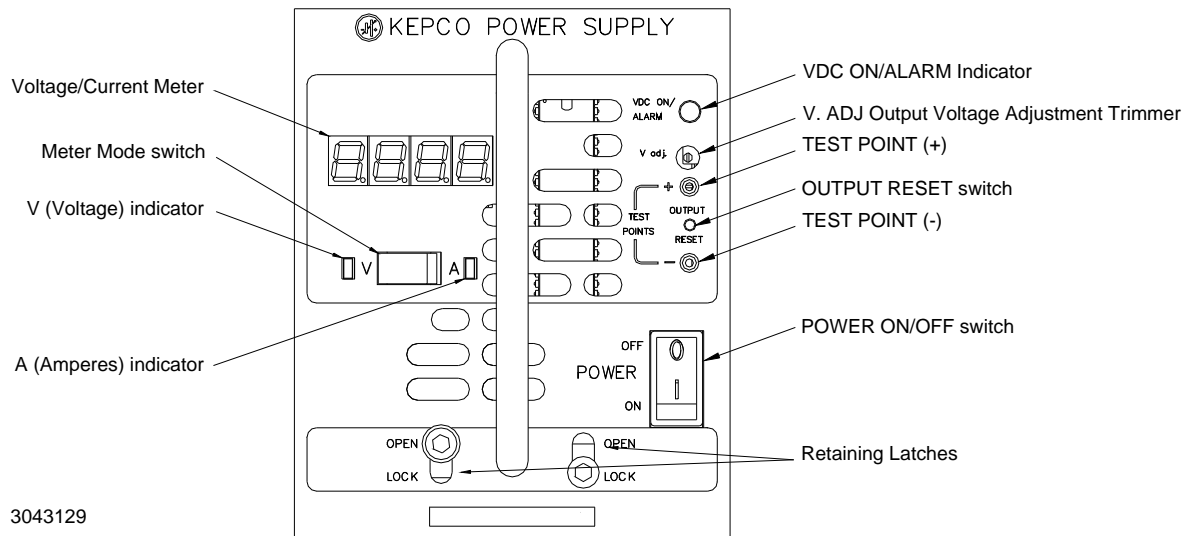

- VDC ON/ALARM indicator. Lights green when unit is operating. Both M and MZ models permit selection of indicator power, either from HSF output or internal reference (see PAR. 3.4.3). When enabled by DIP switch configuration, lights red to indicate loss of output voltage in parallel configuration only (see PAR. 3.8.1).
- V.ADJ Output voltage adjustment trimmer: Adjusts output voltage within limits specified in Table 2 (see PAR. 3.4.1). Not functional if remote voltage control is enabled (see PAR. 3.4.2).
- TEST POINT (+, -): Connect to voltmeter to monitor d-c output voltage.
- OUTPUT RESET switch. Used to recycle power in the event of an alarm condition (see PAR. 3.6). Not functional when remote on/off control is enabled (see PAR. 3.4.3).
- POWER ON/OFF switch. Applies power to the unit. **CAUTION: Power must be OFF before unit is removed from the rack adapter.**
- Retaining Latches (2). Prevents inadvertent removal of unit from rack adapter (see PAR. 3.10).
- Voltage/Current meter: Monitors output voltage or current according to setting of Meter Mode switch. NOTE: Use remote sensing for voltmeter to display voltage at the load.
- Meter Mode slide switch: Set to V for display to show output voltage, set to A to show output current.
- V indicator: Lights green to indicate meter is showing Volts.
- A indicator: Lights amber to indicate meter is showing Amperes.

**FIGURE 5. FRONT PANEL CONTROLS, INDICATORS AND TEST POINTS**

### 3.4 OUTPUT VOLTAGE CONTROL

Output Voltage can be controlled from either the front panel (PAR. 3.4.1) or externally using a tripoint or voltage source (PAR. 3.4.2).

#### 3.4.1 FRONT PANEL VOLTAGE CONTROL

Output voltage can be manually adjusted with the voltage adjustment control, Vadj (see Figure 5 for location) when DIP switches SW1 and SW2 (see Figure 4 for location) are configured as shown in Figure 6A (factory default) To adjust voltage, first place the unit under an operating load. Then monitor the (+) and (-) test points on the front panel with a precision voltmeter and turn the voltage control to the desired operating value. Refer to Table 2 for the recommended Adjustment Range of all the HSF 300W M and MZ Models.

#### 3.4.2 REMOTE VOLTAGE CONTROL

For remote voltage control, set positions 1, 2 and 7 as shown in Figure 6B. This removes control from the front panel Vadj control and allows the output voltage to be adjusted by either an external

trimmer pot (resistance) or by an external variable voltage source connected across the rack adapter I/O connector pin 12 (RV, Remote Voltage) and pin 10 (–COM, Common) as shown in Figure 7. At the rack adapter I/O connector use a shielded wire 6.6 feet (2M) maximum in length, for connection of REF (pin 2), RV (pin 12), and –COM (pin 10) to the trimmer control or external voltage source.

NOTE: If remote voltage control is not implemented, the factory default for positions 1, 2 and 7 of DIP switches SW1 and SW2 must be restored (Figure 6A).

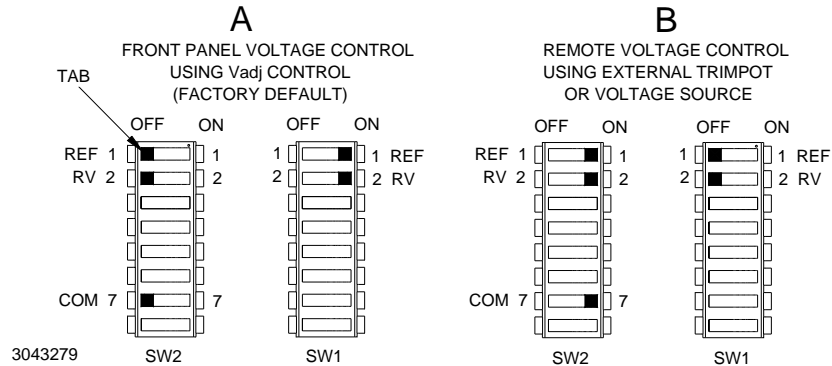

FIGURE 6. DIP SWITCH SETTINGS FOR CONTROL OF OUTPUT VOLTAGE

It is possible that overvoltage protection may be triggered if the output voltage is decreased to a low level very quickly when the power supply is at a low load condition.

**RESISTANCE:** Connect the external trimmer as shown in Figure 7A. Suggested value for the trimmer control is 5K ohms. **For M Models only:** Resistor R (see Figure 7A) is used to obtain minimum output voltage required to ensure proper operation of the alarm relay and LED indicator; see Table 4 for values. NOTE: Output voltage may not adjust to 0V due to residual trimmer resistance.

**VOLTAGE.** By adjusting an external 0 to 6V voltage source (0 to 5.5V for the 48V model), the HSF power supply output voltage can be adjusted as specified in Table 2.

**For M Models (except HSF 5-60M) only:** To ensure proper operation of the alarm relay, meter and LED indicators, do not adjust external voltage below minimum listed in Table 4. Connect the voltage source across the RV and –COM pins as shown in Figure 7B.

**For MZ Models and HSF 5-60M only:** The meter and relay are powered internally and are not dependent on HSF output to maintain function.

TABLE 4. MINIMUM CONDITIONS FOR RELAY, METER AND LED OPERATION

HSF MODEL	5-60M <sup>2</sup>	12-27M	15-22M	24-14M	28-12M	48-7M
Minimum HSF output voltage required for continuous relay, meter and LED functioning (Volts d-c); startup minimum are 0.5V higher except for HSF 5-60M. <sup>1</sup>	No limit	5.5	7	7	7	7
Minimum resistance of Limit resistor R (Figure 7A) in series with 5K ohm Trimpot to ensure proper operation of LEDs, meter and relay (Ohms). <sup>1</sup>	No limit	2.61K	1.91K	1.3K	1.1K	634
Minimum external voltage (Figure 7B) to ensure proper operation of LEDs, meter and relay. (Volts d-c). <sup>1</sup>	No limit	2.3	2.43	1.43	1.28	0.68
Voltage source range (Volts d-c)	0 - 6	0 - 6	0 - 6	0 - 6	0 - 6	0 - 5.5

<sup>1</sup> - If operating below minimums listed, see PAR. 3.8.2.2 to implement ±PF alarm signals to monitor power supply status.

<sup>2</sup> - 5V model includes auxiliary supply that powers the relay, meter and LED independent of output voltage.

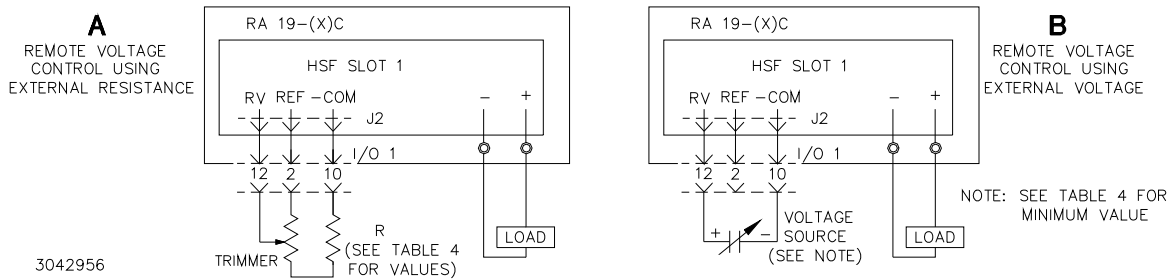

**FIGURE 7. CONNECTIONS FOR REMOTE VOLTAGE CONTROL**

### 3.4.3 VDC ON/ALARM INDICATOR POWER OPTIONS

To use the internal power supply reference voltage to power the VDC ON/ALARM indicator, set Position 7 of SW1 to ON and Position 8 of SW2 to OFF (default) (see Figure 8A). Load effect is  $\pm 1\%$  maximum. To use the HSF output voltage to power the VDC ON/ALARM indicator, set Position 7 of SW1 to OFF and Position 8 of SW2 to ON (see Figure 8B). Load effect is  $\pm 0.6\%$  maximum, however the minimums specified in Table 5 must be observed for the indicator to function.

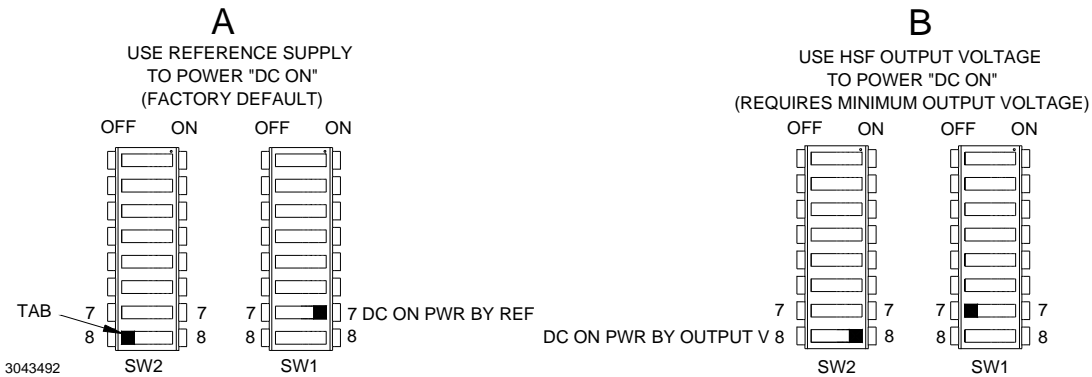

**FIGURE 8. DIP SWITCH SETTINGS FOR VDC ON/ALARM POWER OPTIONS**

Table 5 lists the minimum HSF output voltage required to maintain VDC ON indicator function for this case. Maximum output voltage of unit might cause overvoltage trip if SW2, position 8 is enabled. If this occurs, turn Vadj trim pot counterclockwise to reduce output voltage, then reset the unit.

**TABLE 5. CONDITIONS FOR VDC ON/ALARM LED OPERATION POWERED BY OUTPUT**

MODEL	HSF 5-60M	HSF 12-53MZ	HSF 15-43MZ	HSF 24-27MZ	HSF 28-23MZ	HSF 48-13MZ
Minimum HSF output voltage required for VDC ON LED to function when SW 2 position 8 is ON and SW 1 position 7 is OFF (Volts d-c).	3.3	3.3	3.5	4.5	5	8

### 3.5 REMOTE ON-OFF

When power is ON at the source, the output may be turned ON or OFF using the  $\pm RC$  signals if the remote ON-OFF feature is enabled. Note that when remote ON-OFF is enabled, the RESET OUTPUT switch does not function. Remote ON-OFF is enabled by setting DIP switch positions 3 and 4 as shown in Figure 9B. The +RC and -RC signals (at the rack adapter I/O connector, pins 15 and 8, respectively) then turn the unit on or off. These pins accept a logic level (2.4V to 24V

“high” and 0.0 to 0.4V “low”), or a contact closure. When the  $\pm$ RC pins are open, using either a mechanical switch or a high level logic signal, the HSF output is cut OFF. When the  $\pm$ RC pins are shorted, the output returns to within specifications. At low level logic, the maximum source current is 1.6mA and at high level the sink current is 1.0mA. Positions 3 and 4 of both DIP switches must be restored to the factory default setting (Figure 9A) if remote ON-OFF is not used. The  $\pm$ RC pins are isolated from DC output pins and a-c input terminals.

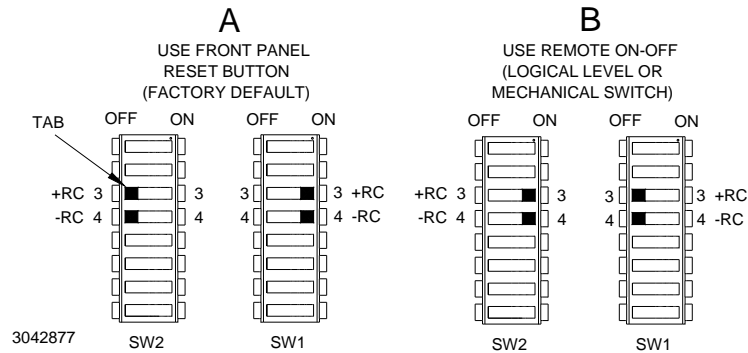

**FIGURE 9. DIP SWITCH SETTINGS FOR USING RESET BUTTON OR REMOTE ON-OFF**

### 3.6 RESET (RESTART)

There are three ways to reset the unit:

- If remote on/off feature (see PAR. 3.4.3) IS NOT in use, press and release the OUTPUT RESET switch on the front panel.
- If the remote on/off feature IS in use (see PAR. 3.4.3), open the connection between the  $\pm$ RC pins and then reconnect the pins.
- The unit may also be restarted by turning the POWER ON/OFF switch to OFF, waiting 40 seconds, then setting the POWER switch to ON.

### 3.7 PROTECTION CIRCUITS

The following protection features are implemented in the HSF 300W Series M and MZ Models: overvoltage and overtemperature (PAR. 3.7.1), overcurrent (PAR. 3.7.2), fan failure (PAR. 3.7.3), and undervoltage (PAR. 3.7.4). The HSF provides a configurable visual alarm (see PAR. 3.8.1) as well as an option to use either relay contacts or logic levels for alarm signals (see PAR. 3.8.2)

#### 3.7.1 OVERVOLTAGE AND OVERTEMPERATURE PROTECTION

When the output voltage of the HSF increases beyond the specified values (see Table 2), the output is cut OFF and the fan turns OFF. After shut down, reset (restart) the unit per PAR. 3.6.

When the internal temperature of the HSF increases beyond allowable limit, the output is cut OFF and the fans turn OFF. The restart cycle (Power ON) should not begin until the temperature returns to within specifications. To restart (reset) the unit, set the POWER ON/OFF switch to OFF, wait until unit cools, then set the POWER switch to ON. The power supply cannot be reset using the remote ON-OFF feature unless the power supply remains shut down for at least 40 seconds.

### 3.7.2 OVERCURRENT SETTING AND PROTECTION

The output characteristic of the power supply is a square type, and the unit is set to produce an alarm (see PAR. 3.8.2) and shut down if output current exceeds specifications (see Table 2) for more than 30 seconds. After the cause of overcurrent is removed, the power supply output is automatically restored. and shut down if output current exceeds specifications (see Table 2) for more than 30 seconds. After shut down, reset (restart) the unit per PAR. 3.6.

### 3.7.3 FAN FAILURE

A cutoff of the fan supply voltage or a decrease in fan speed causes the output to shut down and the fans to turn OFF. Fan failure and all the other protection circuit operations produce an alarm (see PAR. 3.8.2). After shut down, reset (restart) the unit per PAR. 3.6. If fan rotation is out of specification the power supply will not recover.

### 3.7.4 UNDERVOLTAGE

**M MODELS ONLY:** If power supply output voltage either falls below 80% of the programmed (set) value, or if output voltage is programmed below the minimum values listed in Table 4, an alarm occurs if the internal relay alarm (factory default, see PAR. 3.8.2.1) is enabled. After shut down, reset (restart) the unit per PAR. 3.6. To enable the alarm function when operating below the minimum values listed in Table 4, refer to PAR. 3.8.2.2 to configure the optically-coupled alarm.

**MZ MODELS ONLY:** If power supply output voltage falls below 80% of the programmed (set) value, an alarm occurs. After shut down, reset (restart) the unit per PAR. 3.6.

## 3.8 ALARM SETTINGS

### 3.8.1 VISUAL ALARM.

When the unit is connected in a parallel configuration, the front panel VDC ON/ALARM indicator can be configured to light red if the respective power supply output voltage is lost or if the POWER switch is set to OFF. This is enabled when DIP switch 1, position 8 set to ON. This can be useful to indicate the loss of output voltage from one parallel-connected power supply that may not be readily apparent. The visual alarm is normally disabled: DIP switch SW1, position 8 set to OFF (factory default); requires minimums per Table 4 if enabled (see PAR 3.9). Only one of these two must be enabled, the other disabled.

**NOTE:** On MZ models, the meter is powered by an independent internal power supply and will most likely remain lit after a failure. Visual inspection of the front panel VDC ON/ALARM indicator and/or monitoring of the alarm signals is required to detect a failure. If the ALARM indicator is enabled to light red, the VDC ON/ALARM indicator must be powered from the HSF output (see PAR. 3.4.3).

### 3.8.2 ALARM SIGNALS.

Either of two options are available for signalling alarms: isolated relay contacts (factory default, PAR. 3.8.2.1) or logic level alarm signals  $\pm$ PF (PAR. 3.8.2.2). The  $\pm$ PF logic level alarm option must be used if the power supply is intended to operate below the minimum voltages listed in Table 4.

#### 3.8.2.1 INTERNAL ISOLATED RELAY ALARM

The first option, the factory default setting, uses an isolated internal relay offering normally closed (NC) and normally open (NO) contacts referenced to an isolated common (AL COM). These contacts may be used to configure "close on failure" or "open on failure" alarm circuits. (Refer to the Series RA 19-4C Manual for alarm configurations for multiple HSF power supplies.) Setting positions 5 and 6 of the DIP switches as shown in Figure 10A selects this option. The NC (pin 6 of the rack adapter I/O connector) and NO (pin 7) signals are referenced to Alarm common (pin 14).

### 3.8.2.2 OPTICALLY-COUPLED LOGICAL ALARM

The second option uses optically-coupled logic level alarm signals, +PF (pin 5 of the rack adapter I/O connector) and -PF (pin 13), provided directly from the Kepco RKW power supply that is the heart of the HSF. This option is selected by setting positions 5 and 6 of the DIP switches as shown in Figure 10B. Use this option if the power supply will operate below the minimum voltages specified in Table 4.

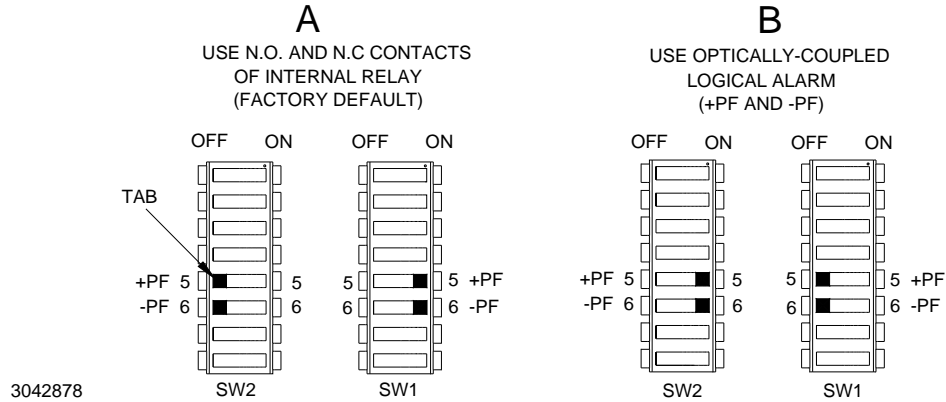

**FIGURE 10. DIP SWITCH SETTINGS FOR OPTICALLY COUPLED LOGICAL ALARM**

The logic alarm circuit is a diode transistor optical coupler (see Figure 11). The transistor is normally conducting. When the alarm is activated upon detection of power loss, overvoltage, fan fault, overtemperature or overcurrent condition, the transistor cuts off and the collector emitter circuit is open. Figure 12 is a timing diagram of the power fail signal.

The default state of the alarm is logic low. The sink current for the optocoupler is 50mA maximum, the maximum collector to emitter saturation voltage is 0.40 Volts, and the collector to emitter voltage is 40 volts maximum. The PF signals are isolated from the AC input and DC output.

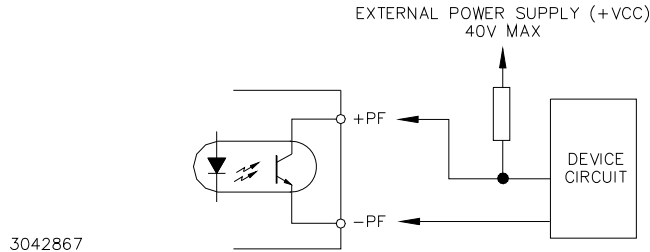

**FIGURE 11. OUTPUT ALARM CIRCUIT OPTICALLY ISOLATED**

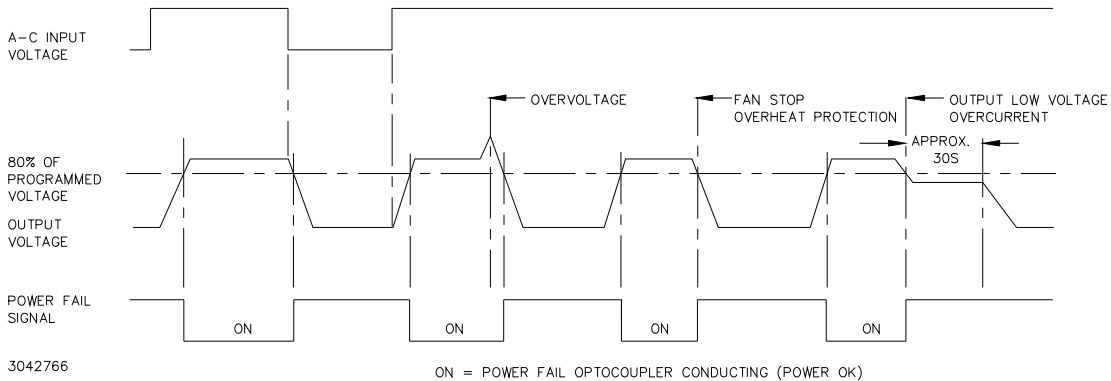

**FIGURE 12. ±PF POWER FAILURE OPTOCOUPLER TIMING DIAGRAM**

### 3.9 LOCAL/REMOTE SENSING

HSF (M and MZ) 300W Power Supplies allow remote error sensing which can compensate up to 0.4 Volts per load wire. Local/Remote error sensing is configured by means of separate DIP switches mounted on the RA 19-4C Rack Adapter (see RA 19-4C Rack Adapter Operator Manual). Either local or remote sensing **MUST** be used, otherwise the units will not operate.

### 3.10 RETAINING LATCHES

HSF power supplies are provided with (2) retention latches located at each side of the bottom edge of the front panel (see Figure 5). These latches work in conjunction with the RA 19-4C rack adapters to prevent unauthorized or inadvertent module extraction from an operating power system. The latch is engaged by loosening the cap-head screw approximately 1/2 turn CCW (use 5/32" hex key) and sliding the latch down to the bottom of the slot, then retightening the cap-head screw CW until snug. **DO NOT OVERTIGHTEN!** To release, follow the same procedure, except lift the latch to the top of the slot. Be sure to move the latch completely up or down to ensure full engagement and disengagement of the latching mechanism. When the HSF power supply is not installed in its plug-in rack adapter, it is recommended that the latch be secured in the open (up) position to prevent damage.

NOTE: Retaining latches must *not* be used to secure the HSF power supply in the rack adapter for shipping purposes.

## 4. LOAD CONNECTION

Connect the load to (+) and (-) terminals at the rear panel of the Rack Adapter (see RA 19-4C Instruction Manual for details).

## 5. CONNECTING MULTIPLE POWER SUPPLIES

All connections to multiple HSF power supplies must be made via the I/O mating connectors at rear of the Rack Adapter or by the Rack Adapter DIP switches. These connections, including the configuration of the two internal HSF DIP switches, are described in the Rack Adapter Instruction manual, and include:

- Using one power supply to control the output of multiple supplies.
- Using parallel master/slave configurations (for increased current or redundancy) where the user either predetermines the master or allows the load to determine which is the master. These configurations also cover the use of the Current Balancing feature of the HSF power supply.
- Using series configurations (for increased voltage).
- Using open-on-fail or close-on-fail alarm schemes with multiple power supplies.



## 5.1 ADJUSTING THE VOLTAGE

NOTE: Refer to the RA 19-4C Rack Adapter manual for alternatives to the standard master/slave parallel configuration described below.

To adjust the paralleled units, turn off all the units except one (designated as the master) and adjust to desired voltage using the front page trimmer and monitoring the front panel voltmeter.

- Each slave must be adjusted to a slightly lower voltage than the previous unit. The difference between the master and the lowest voltage slave must not exceed 2% of  $E_{NOM}$ .
- The voltage separation between master and subsequent slave(s) ( $V_{SEP}$ ) =  $2\% E_{NOM} / N$  where N = number of units in parallel.

Adjust the first slave  $V_{SLAVE1}$  to  $E_{NOM} - V_{SEP}$ . Adjust the second slave  $V_{SLAVE2}$  to  $V_{SLAVE1} - V_{SEP}$ . Adjust the third slave  $V_{SLAVE3}$  to  $V_{SLAVE2} - V_{SEP}$  and so on.

As an example, for three HSF 24-27M units in parallel, 2% of  $E_{NOM}$  is 0.48V and  $V_{SEP}$  is  $0.48/3 = 0.16V$ . Turn off the master, then turn on another unit (slave 1) and adjust for 160mV less than the master. Turn off slave 1 and turn on slave 2 and adjust for 160mV less than slave 1.

When all units are turned on, the unit adjusted to the highest voltage will be the master. The meters of all units read the voltage on the bus. If a unit fails, the VDC ON indicator of that unit is either off or red, however the meter of a failed MZ Model may continue to read the voltage on the bus since it is powered by a separate internal power supply.

## 5.2 PARALLEL CONNECTIONS, M MODELS

When using parallel-connected M Models, a minimum load is required to avoid the slave becoming "idle." When the slave is idle, the output is off, no lights are lit, and the alarm is set. The minimum load (Amperes) =  $N \times (I/10)$  where N = the number of units in parallel, I = Nominal current rating of individual power supply (Amperes). For applications requiring either no load or lower than minimum load conditions, the MZ Models are recommended.

## 5.3 PARALLEL CONNECTIONS, MZ MODELS

If parallel-connected MZ models are controlled individually, either a minimum load or voltage set restrictions are required to avoid slave "idle" or slave "oscillating output" conditions; the idle and oscillating output conditions show slightly different indications depending on the position of SW1 position 7 as defined below. **NOTE: If the minimum load is maintained, voltage set restrictions are not required.**

If position 7 of SW1 is set to off (default, see PAR. 3.1), the VDC ON indicator is powered from the output; therefore when a slave is idle, the output is off, VDC ON is off, and the alarm is set. The oscillating output condition means that the unit alternates between briefly idle and output on (the VDC ON indicator will appear dim as it goes on and off, and the toggling relay will be audible).

If position 7 of SW1 is set to on (see PAR. 3.1) so that the VDC ON indicator is powered from the internal power supply, when a slave is idle, the output is off, VDC ON lights red, and the alarm is set. The oscillating output condition means that the unit alternates between briefly idle and output on (the VDC ON indicator will toggle between briefly amber and green, and the toggling relay will be audible).

### 5.3.1 MINIMUM LOAD

The minimum load (Amperes) =  $N \times (I/10)$  where N = the number of units in parallel, I = Nominal current rating of individual power supply (Amperes). For applications requiring no load or lower than minimum load conditions, see voltage set restrictions of PAR. 5.3.2. Load effect specifications will not be met when units are operated in redundant mode with load less than 10% per unit.

For loads less than 10%, voltage stabilization may be affected if units are turned off and on via the front panel, causing voltage on the paralleled bus to rise as high as 8% for 5 seconds maximum. This can be avoided by using the remote on-off feature to turn the units off and on.

### 5.3.2 VOLTAGE SET RESTRICTIONS

To avoid slave "idle" all parallel-connected units' output voltage must be set within 1% or 200mV of each other (whichever is lower) and be at least 80% of their nominal (rated) output voltage (90% for 48V model).

NOTE: If newer HSF-A models are to be connected in parallel with the models covered in this manual, the voltage restrictions for the HSF-A models must be observed: the output voltage of all parallel-connected units must be set within 0.5% of each other and be at least 80% of their nominal (rated) output voltage (90% for 48V model).