

INSTRUCTION MANUAL



KEPCO An ISO 9001 Company.

CA 45-R COVER

ENCLOSURES AND HARDWARE SYSTEMS

DESCRIPTION. The Kepco Model CA 45-R RoHS-compliant Cover (see Figure 1) is supplied for use with Kepco Series RTW 50 Watt power supplies. The cover includes two M3 X 6mm screws (Kepco P/N 101-0433) used to attach the cover to the power supply as shown in Figure 1. These screws must not be overtightened (max. torque 10 in.- lbs (1.1 N x m). Refer to Figure 2 for outline dimensions.

REMOVE EXISTING SCREW (M3 x 8) FROM
RTW POWER SUPPLY AND USE TO SECURE
COVER TO POWER SUPPLY.
MAX TORQUE 10 IN.-LBS (1.1N x m)

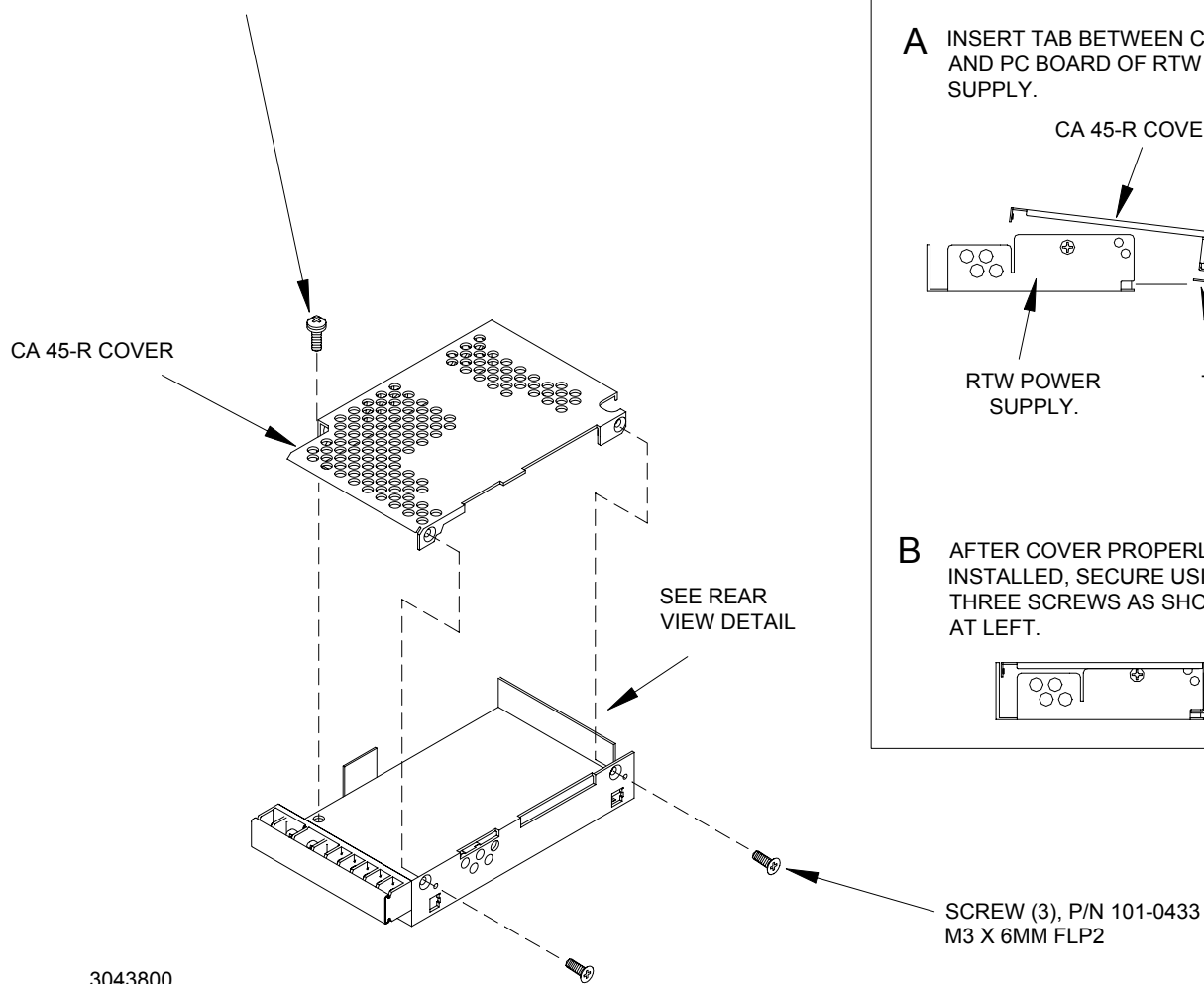
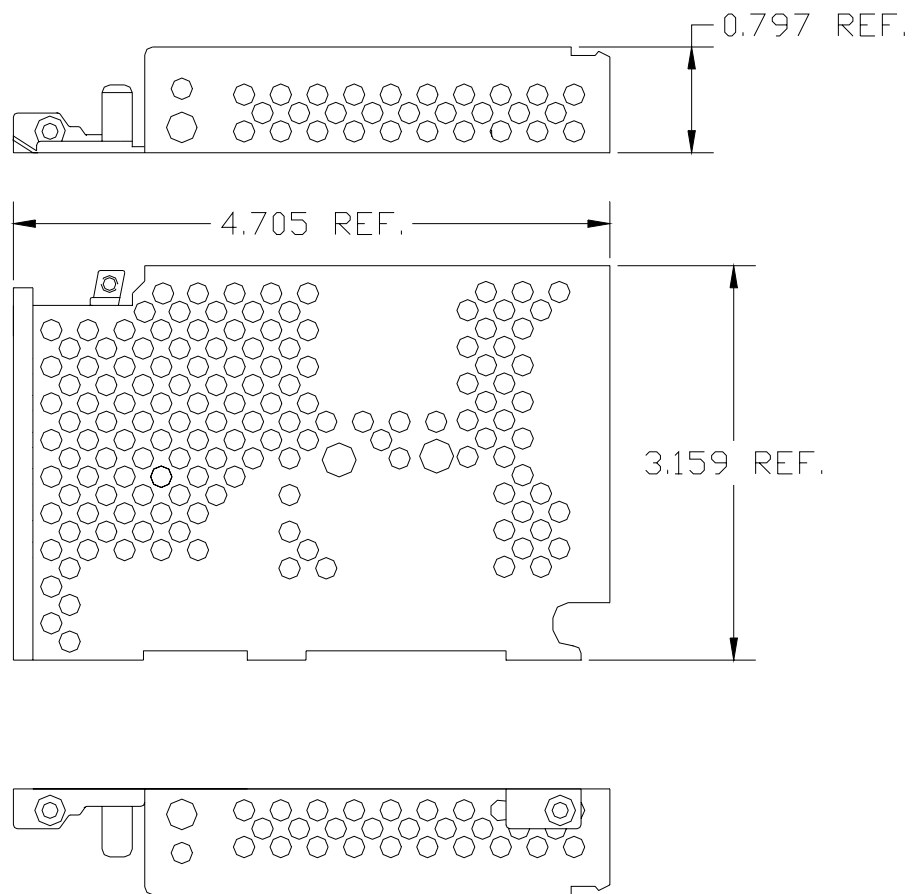

FIGURE 1. CA 45-R COVER INSTALLATION



3043799

FIGURE 2. CA 45-R OUTLINE DIMENSIONS