

INSTRUCTION SHEET

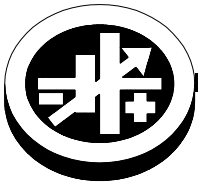

KEPCO An ISO 9001 Company.

**MA
RKW/HWS
-300H**

MOUNTING ADAPTER RKW/HWS-300H

DESCRIPTION. Each Mounting Adapter includes an adapter plate and mounting screws that allow a horizontally-mounted HWS300 power supply to be easily substituted for a horizontally-mounted 300W RKW power supply. Note that some HWS dimensions may exceed corresponding RKW dimensions; verify proper fit prior to installation. Mount the adapter plate to the HWS power supply using the screws and spacers provided (see Figure 1), then install the adapter plate in place of the RKW power supply using the screws previously used to mount the RKW power supply.

NOTES:

1. MOUNT ADAPTER PLATE TO POWER SUPPLY AT HOLES "A" USING FOUR SPACERS P/N 104-0312, AND FOUR SCREWS P/N 101-0487.
2. REMOVE RKW POWER SUPPLY AND SAVE MOUNTING SCREWS, THEN INSTALL ADAPTER PLATE WITH HWS300 POWER SUPPLY ATTACHED AT HOLES "B" USING MOUNTING SCREWS SAVED. (MOUNTING SCREWS ARE M4, LENGTH NOT TO EXCEED 8MM.)

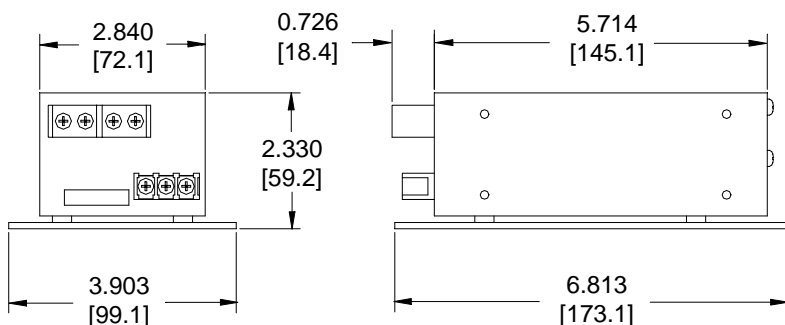

3044172

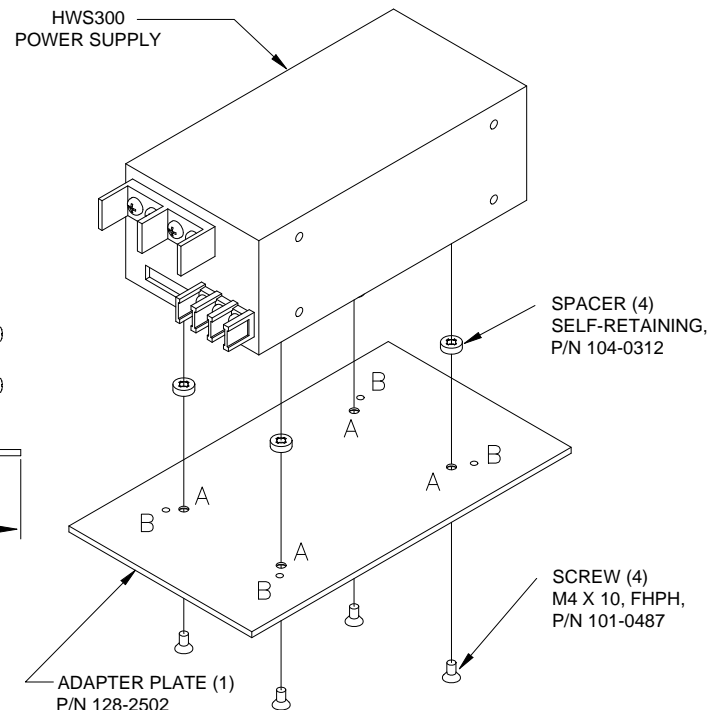

FIGURE 1. ADAPTER PLATE INSTALLATION