

INSTRUCTION MANUAL



KEPCO An ISO 9001 Company.

**KIT
219-0643**

SERIES CONNECTION KIT FOR TWO BOP 20V LINEAR POWER SUPPLIES

1 DESCRIPTION.

This KIT allows local or remote control of two identical single channel 20V BOP (BOP 20-5, BOP 20-10 or BOP 20-20) units connected in a series master/slave configuration. The kit contains one output power cable (P/N 118-1463) for connecting the Master OUT terminal to the slave COM terminal and a control cable (P/N 118-1457) that facilitates proper configuration of the master and slave PC 15 rear programming connections to allow local analog control of the master/slave pair, and configures the circuit breakers of the units so that if the circuit breaker of one BOP trips, the other unit in series trips as well (see Circuit Breaker Control Circuit paragraph in the BOP Operator's Manual for details).

NOTE: The BOP Operator's manual can be downloaded from the Kepco web site at:

www.kepcopower.com/support/opman1s.htm#bop

This control cable has two rear programming connectors marked MASTER and SLAVE to indicate which one is connected to the master and which one to the slave. The PC 15 connectors have been modified as follows:

- The connection between pin 26 and pin 36 is interrupted on the PC 15 for both the MASTER and SLAVE.
- The interconnections of cable 118-1457 are shown in the schematic diagram, Figure 3.

2 INSTALLATION

1. Connect two BOP's units in series as shown in Figure 1 for remote sensing or Figure 2 for local sensing.
 - The wire connections between BOP OUT and COM to the load should be rated for the nominal output current of the unit.
 - For load wiring recommendations (power and sense) refer to the Load Connection paragraph in the BOP Operator's manual.
 - For AC and DC grounding recommendations, refer to A-C Grounding and D-C Grounding paragraphs in the BOP Operator's manual.
 - All the output wires' insulation should be rated for 300V.
 - Both units should be supplied from a common AC source.

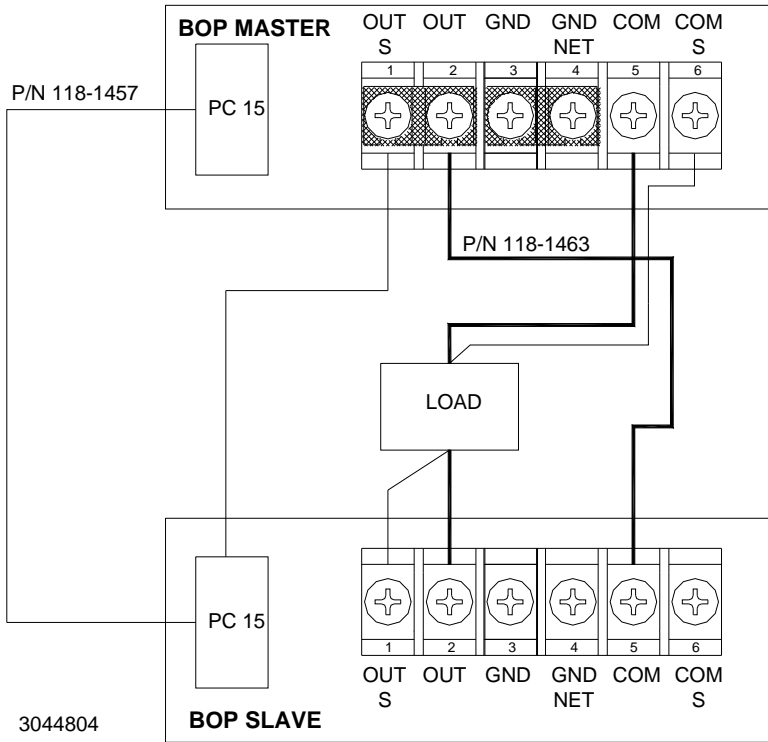

NOTES (MASTER):

1. Set MODE Switch to VOLTAGE for Voltage Mode or to CURRENT for Current Mode.
2. For Voltage Mode set VOLTAGE CONTROL switch to ON for local control and to OFF for remote analog control.
3. For Current Mode set CURRENT CONTROL switch to ON for local control and to OFF for remote analog control.
4. Install sense link between OUT and OUT S terminals.
5. Remove link between COM and COM S terminals.

NOTES (SLAVE):

1. Set MODE Switch to VOLTAGE.
2. Set VOLTAGE CONTROL switch to OFF.
3. Remove local sensing links between COM and COM S and between OUT and OUT S terminals.
4. Remove link between terminals 4 and 5 on rear barrier strip (removes grounding network).
5. Disconnect any external voltage control applied to the slave front panel Voltage Programming Input.

3044804

FIGURE 1. BOP 20V, SERIES CONNECTIONS USING KIT 219-0643, REMOTE SENSING

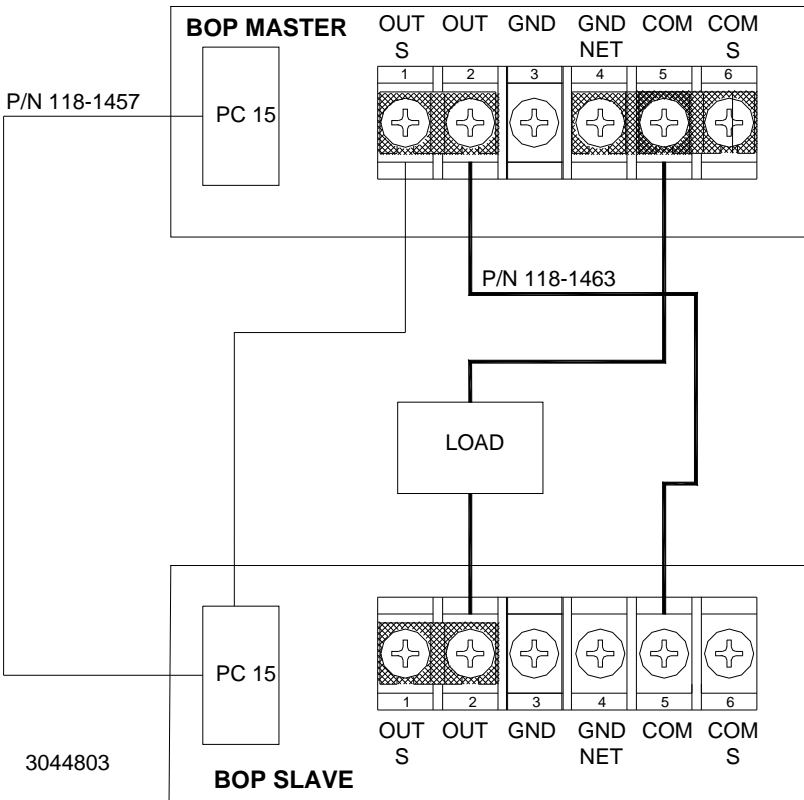

NOTES (MASTER):

1. Set MODE Switch to VOLTAGE for Voltage Mode or to CURRENT for Current Mode.
2. For Voltage Mode set VOLTAGE CONTROL switch to ON for local control and to OFF for remote analog control.
3. For Current Mode set CURRENT CONTROL switch to ON for local control and to OFF for remote analog control.
4. Install sense links between OUT and OUT S and between COM and COM S terminals.

NOTES (SLAVE):

1. Set MODE Switch to VOLTAGE.
2. Set VOLTAGE CONTROL switch to OFF.
3. Install local sensing link between OUT and OUT S terminals and remove link between COM and COM S terminals.
4. Remove link between terminals 4 and 5 on rear barrier strip (removes grounding network).
5. Disconnect any external voltage control applied to the slave front panel Voltage Programming Input.

3044803

FIGURE 2. BOP 20V, SERIES CONNECTIONS USING KIT 219-0643, LOCAL SENSING

- Set the master BOP as specified in the notes of Figure 1 (remote sensing) or Figure 2 (local sensing).
- Set the slave BOP as specified in the notes of Figure 1 (remote sensing) or Figure 2 (local sensing).

NOTE: If a BIT card is installed in the slave, it must be disabled to allow analog control from the master unit.. See application note titled "How to Disable BIT Card in a) BOP models with BIT 802E or 4886 Cards Installed or b) BOP 2X-DE Models," The application note also explains how to configure digital control of a master/slave combination. The application note can be downloaded from the Kepco web site at:
www.kepcopower.com/support/bop-app-note.htm

- Connect the wire with terminal lug from the PC 15 labeled SLAVE to Master OUT S terminal at the master rear terminal block.

3 OPERATION

The Master unit can be controlled either locally and/or by remote analog signals, or through digital commands using a BIT card. When using a BIT card, the analog control (local or remote) is disabled.

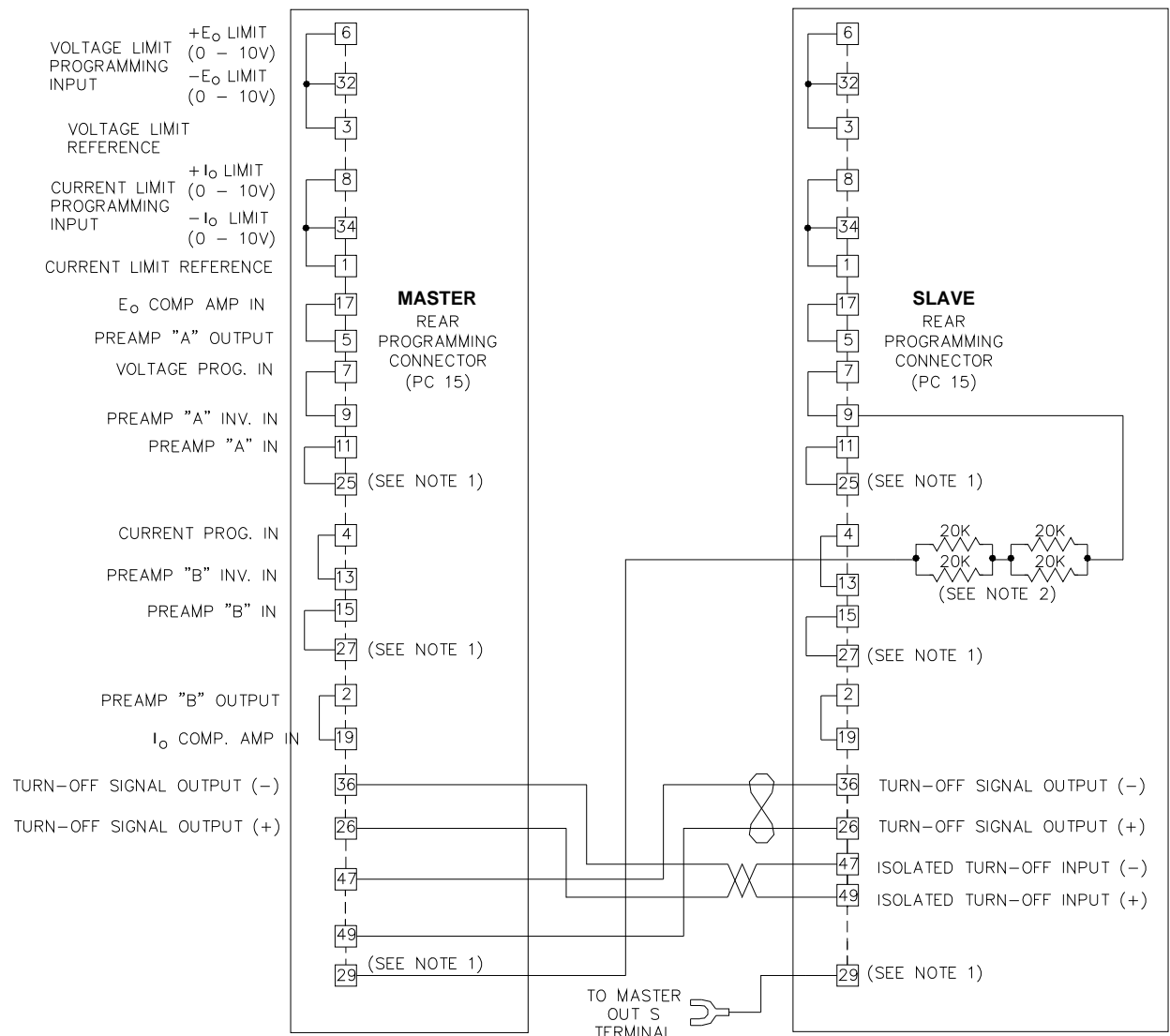

3044802
 NOTES:
 1. PINS 23, 25, 27, 29, 31 AND 33 ARE CONNECTED TO COMMON ON BOP A1 BOARD.
 2. FOUR RESISTORS ARE PART OF CABLE 118-1457: 20K OHMS, 0.1%, 1/8W (Kepco P/N 115-2884).

FIGURE 3. CONTROL CABLE (P/N 118-1457) FOR LOCAL CONTROL OF BOP 20V SERIES-CONNECTED MASTER/SLAVE PAIR, SCHEMATIC DIAGRAM