



**MODIFICATION OF STANDARD  
KEPCO MODEL BOP 100-2MC  
KEPCO MODEL BOP 100-2DC**

The Kepco Models BOP 100-2MC and BOP 100-2DC have been modified from standard Kepco Models BOP 100-2M and BOP 100-2D, respectively, to be stable handling capacitive loads up to 10 mF.

**INSTRUCTION MANUAL CORRECTIONS:**

This modification makes the BOP more suitable for a wide variety of applications such as solar cell/ solar panel testing, piezoelectric device driving/ testing, capacitor testing, capacitive transducer driving/testing and powering industrial or lab-type applications for capacitive or capacitive-resistive loads.

Static specifications representing the unit's accuracy in Voltage mode are identical with the standard BOP models, while the ripple and noise specifications are better (approximately 50% lower) for MC and DC models than standard BOP models.

Specifications listed in Table 1 are for BOP 100-2MC and BOP 100-2DC in Voltage Mode.

**TABLE 1. BOP 100-2MC AND BOP 100-2DC SPECIFICATIONS**

Bandwidth (DC to f-3dB)		Rise/Fall Time <sup>(2)</sup>	Recovery at Step Load <sup>(3)</sup>
Resistive Load, Nominal	Capacitive Load, 10 $\mu$ F <sup>(1)</sup>		
5.0 kHz	5.6 kHz	74 $\mu$ S	115 $\mu$ S

NOTES:

- (1) Nonuniformities of the frequency response for the standard 10 $\mu$ F load create a larger 3-dB bandwidth than for the resistive load.
- (2) 10% to 90%, with nominal resistive load.
- (3) Load between infinity and nominal resistive load values.

In voltage mode the bandwidth of the BOP 100-2MC and DC models is less than the standard BOP, while the response time is increased. Nonuniformities of the frequency response can be nearly eliminated by reducing the bandwidth in Voltage mode. Bandwidth can be reduced in a predictable manner by increasing the internal compensation capacitance by placing an external capacitor in parallel across C21 of Assembly A1 (see Table 2 and Figure 1).

**TABLE 2. BANDWIDTH CORRECTION**

	EXTERNAL CAPACITOR (ACROSS A1C21, SEE FIGURE 1)						
	1 nF	2.2 nF	4.7 nF	15 nF	33 nF	47 nF	100 nF
CORRECTED BANDWIDTH	4.9 kHz	4.7 kHz	4.1 kHz	2.7 kHz	1.4 kHz	1.05 kHz	0.65 kHz

NOTE: Listed bandwidth correction values are for Voltage mode, nominal resistive load.

In Current Mode the dynamic specifications are almost identical for all BOP MC and DC models: 3-dB bandwidth of 4.9kHz and rise/ fall time of 72 $\mu$ s (lower bandwidth and higher rise/ fall time than the standard BOP M and D models).

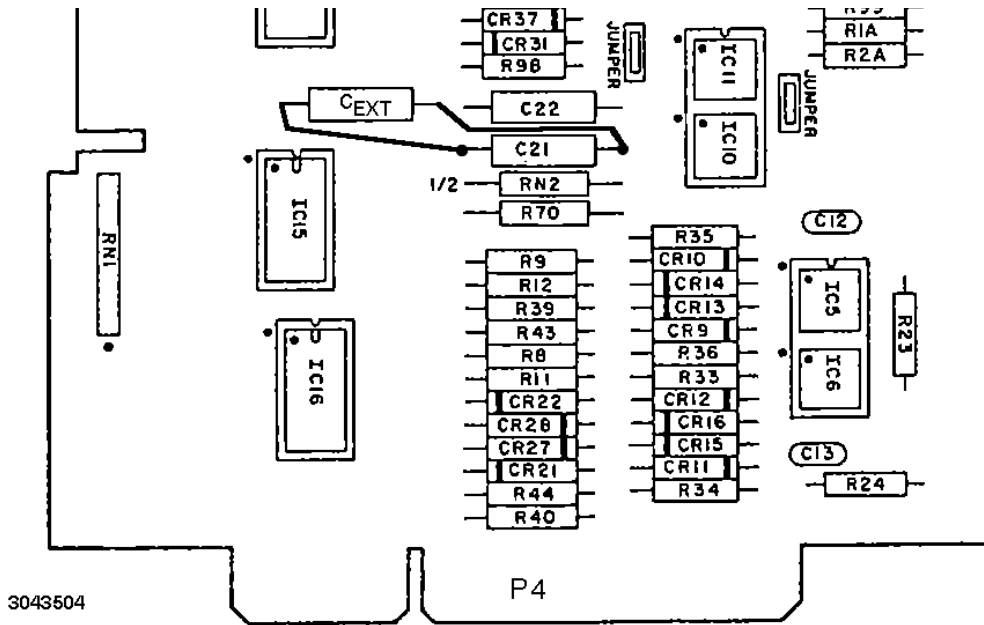

FIGURE 1. ASSEMBLY A1, EXTERNAL BANDWIDTH CORRECTION CAPACITOR LOCATION