

# OPERATOR'S MANUAL

## BOP 2X-D (C) (L) 200W, 400W

### DUAL CHANNEL

### BIPOLAR OPERATIONAL POWER SUPPLY

200W: BOP 2X5-20D, BOP 2X20-5D, BOP 2X50-2D, BOP 2X100-1D  
400W: BOP 2X5-30D, BOP 2X20-10D, BOP 2X36-6D, BOP 2X50-4D,  
BOP 2X72-3D, BOP 2X100-2D

KEPCO INC.

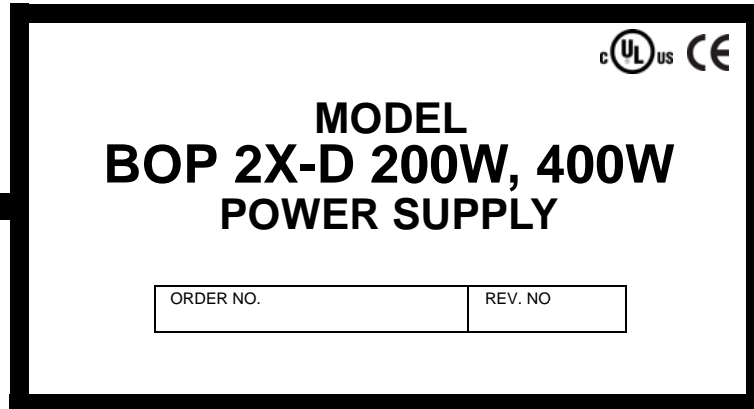

#### IMPORTANT NOTES:

- 1) This manual is valid for the following Model and associated serial numbers:

MODEL	SERIAL NO.	REV. NO.
-------	------------	----------
- 2) A Change Page may be included at the end of the manual. All applicable changes and revision number changes are documented with reference to the equipment serial numbers. Before using this Instruction Manual, check your equipment serial number to identify your model. If in doubt, contact your nearest Kepco Representative, or the Kepco Documentation Office in New York, (718) 461-7000, requesting the correct revision for your particular model and serial number.
- 3) The contents of this manual are protected by copyright. Reproduction of any part can be made only with the specific written permission of Kepco, Inc.

Data subject to change without notice.

©2023, KEPCO, INC  
P/N 243-1387-r7a





# TABLE OF CONTENTS

SECTION	PAGE
<b>SECTION 1 - INTRODUCTION</b>	
1.1	Scope of Manual..... 1-1
1.2	Options ..... 1-1
1.2.1	Meters (D suffix): ..... 1-1
1.2.2	Capacitive Load Optimization (C Suffix):..... 1-1
1.2.3	Inductive Load Optimization (L Suffix):..... 1-1
1.2.4	Digital Control (LAN) (E Suffix):..... 1-1
1.3	General Description..... 1-1
1.4	Electrical Specifications, General ..... 1-2
1.5	Miscellaneous Features..... 1-8
1.5.1	Output Range ..... 1-8
1.5.2	Rear Programming Features..... 1-9
1.5.3	Remote ON-OFF Feature..... 1-12
1.5.4	Load Reactance ..... 1-12
1.5.4.1	Driving an Inductive Load in Current Mode ..... 1-12
1.5.4.2	Driving a Capacitive Load in Voltage Mode ..... 1-13
1.5.5	Remote Turn-off ..... 1-13
1.5.6	Circuit Breaker Shutdown Prevention (at Power Loss) Circuit ..... 1-13
1.5.7	References ..... 1-13
1.5.8	Series Or Parallel Operation ..... 1-14
1.5.9	External Voltage Monitor ..... 1-14
1.5.10	External Current Monitor ..... 1-14
1.5.11	Mode Setting ..... 1-14
1.5.12	Voltage Control Loop..... 1-14
1.5.13	Current Control Loop..... 1-14
1.5.14	Bounding ..... 1-14
1.5.15	Mode Lights ..... 1-15
1.5.16	Standards ..... 1-15
1.6	Mechanical Specifications ..... 1-15
1.7	Equipment Supplied..... 1-16
1.8	Accessories ..... 1-16
1.9	Safety..... 1-16
<b>SECTION 2 - INSTALLATION</b>	
2.1	Unpacking and Inspection..... 2-1
2.2	Terminations, Controls and Indicators ..... 2-1
2.3	A-C Input Requirements ..... 2-3
2.4	Cooling..... 2-3
2.5	Preliminary Checkout..... 2-3
2.6	Installation of BOP 2X-D Series Models ..... 2-5
2.6.1	Slide Installation..... 2-5
2.7	Load Connection..... 2-6
2.7.1	Load Connection, Local Sensing..... 2-6
2.7.2	Load Connection, Remote Sensing..... 2-6
2.7.3	A-c Ground ..... 2-7
2.7.4	D-c Ground..... 2-7
<b>SECTION 3 - OPERATION</b>	
3.1	Introduction..... 3-1
3.2	Power Supply Basics ..... 3-1
3.2.1	PC 15 Rear Programming Connector ..... 3-2
3.2.2	External Programming Resistors..... 3-3
3.2.3	Active Programming Sources..... 3-3
3.2.4	External Leads ..... 3-3
3.2.5	External Voltage Monitor ..... 3-3
3.2.6	External Current Monitor ..... 3-4

# TABLE OF CONTENTS

SECTION	PAGE
3.3	Remote Control of Voltage Loop..... 3-6
3.3.1	Remote Voltage Control Using Resistance (Potentiometer)..... 3-6
3.3.2	Remote Voltage Control Using Resistance (Decade Box) ..... 3-7
3.3.3	Remote Voltage Control Using D-C Signal Voltage..... 3-8
3.3.4	Using the BOP as a Voltage Amplifier ..... 3-10
3.3.5	Remote Control of Current Limiting ..... 3-12
3.4	Remote Control of Current Control Channel ..... 3-13
3.4.1	Remote Current Control Using Resistance (Potentiometer)..... 3-13
3.4.2	Remote Current Control Using Resistance (Decade Box)..... 3-14
3.4.3	Remote Current Control Using D-C Signal Voltage..... 3-14
3.4.4	Using the BOP as a Current Amplifier ..... 3-16
3.4.5	Remote Control of Voltage Limiting ..... 3-18
3.5	Series and Parallel Connection of BOP Channels..... 3-19
3.5.1	Series Connection, Master/slave Operation ..... 3-19
3.5.2	Circuit Breaker Control Circuit ..... 3-21
3.5.3	Parallel Connection, Master/Slave Operation..... 3-23
<b>SECTION 4 - CALIBRATION</b>	
4.1	Introduction ..... 4-1
4.2	Test Equipment Requirements ..... 4-2
4.3	Internal Adjustments and Calibrations ..... 4-3
4.3.1	Adjustment of $\pm 10$ Volt Calibration Controls (R31, R32) ..... 4-3
4.3.2	Preamplifier "A" Zero (R41) ..... 4-4
4.3.3	Preamplifier "B" Zero (R42) ..... 4-4
4.3.4	Voltage Channel Zero Adjustment (R81)..... 4-5
4.3.5	Ammeter Zero Control Adjustment (R50) ..... 4-5
4.3.6	Current Channel Zero Adjustment (R83)..... 4-6
4.3.7	Full Scale Output Current Calibration (R316)..... 4-6
4.3.8	Adjustment of $I_O$ -OFF Zero (A1R133) and $E_O$ -OFF Zero (A1R136)..... 4-7

# LIST OF FIGURES

FIGURE	TITLE	PAGE
1-2	BOP Channel Output Characteristic .....	1-9
1-3	BOP Output WaveForms with Phase Shift .....	1-9
1-4	Boundaries and Limits .....	1-15
1-5	Mechanical Outline Drawing, (BOP 2X-D Series Models) .....	2-17
2-1	BOP 2X-D Terminations and Controls, Front Panel.....	2-1
2-2	BOP 2X-D Terminations and Controls, Rear Panel.....	2-2
2-3	A-C Source Voltage Selection, Each Channel.....	2-3
2-4	Slide Installation on BOP 2X-D Units .....	2-6
2-5	Load Connection (Channel 1, Typ.) Using Local Sensing .....	2-8
2-6	Load Connection Using Remote Sensing .....	2-8
3-1	BOP Basic Voltage Control Loop (Local Sensing).....	3-4
3-2	BOP Basic ( $\pm$ ) Current Limiting Circuit (Local Sensing).....	3-4
3-3	BOP BASIC Current Control (Local Sensing) .....	3-5
3-4	BOP BASIC ( $\pm$ ) Voltage Limiting Circuit (Local Sensing).....	3-5
3-5	Remote Potentiometer Control of D-C Output Voltage .....	3-6
3-6	Remote D-C Output Voltage Control Using Two-Terminal Resistance (Decade).....	3-7
3-7	External Digital Control of the D-C Output Voltage.....	3-8
3-8	D-C Output Voltage Control with Non-inverting Configuration and High Impedance $\pm 1V$ Signal Source ...	3-9
3-9	Graphs Of Possible Input/output Waveshapes .....	3-10
3-10	Basic Programming Circuit for Use of BOP as Bipolar Amplifier (Voltage Mode).....	3-11
3-11	Programming Circuit for Driving Output Voltage with $\pm 1V$ Input Programming Voltage .....	3-11
3-12	Symmetrical Remote Control of the Current Limits.....	3-12
3-13	Independent Remote Control of $+ I_O$ and $- I_O$ Limits.....	3-12
3-14	Remote Potentiometer Control of the BOP Output Current .....	3-13
3-15	Remote D-C Output Current Control Using Two-Terminal Resistance (Decade).....	3-14
3-16	Digital Control of Output Current.....	3-15
3-17	BOP Output Current Control with Non-inverting Configuration and High Impedance ( $\pm 1$ ) Volt Signal Source .....	3-15
3-18	Basic Programming Circuit for BOP as Bipolar Current-stabilized Amplifier.....	3-16
3-19	Programming Circuit for Driving Output Current with $\pm 1V$ Input Programming Voltage.....	3-17
3-20	Programming Circuit for Driving Output Current with a High Impedance Source .....	3-17
3-21	Symmetrical Remote Control of Voltage Limit .....	3-18
3-22	Independent Remote Control of $+E_O$ and $-E_O$ Voltage Limit.....	3-18
3-23	Series Connection, Master/Slave, Voltage Control of two BOP 2X-D Channels with Remote Error Sensing at the Common Load .....	3-20
3-24	Circuit Breaker Control Circuit, Simplified Diagram. ....	3-22
3-25	Parallel Connection (Master/Slave) of Two BOP 2X-D Channels with Remote Error Sensing at the Common Load.....	3-24
3-26	Simplified Schematic Diagram, Channel 1 or 2, BOP 2X-D SERIES.....	3-25
3-27	PC 15/PC 12 Rear Programming Connector Interconnections .....	3-27
4-1	Locations of Adjustment and Calibration Controls .....	4-2

# LIST OF TABLES

TABLE	TITLE	PAGE
1-1	General Specifications .....	1-2
1-2	Input Specifications Per Channel .....	1-7
1-3	Output Ranges, Transfer Factor and Output Impedance per Channel .....	1-7
1-4	Output Dynamic Specifications PER Channel .....	1-8
1-5	Rear Programming Connector (1 per Channel) Terminal Functions .....	1-10
1-6	Equipment Supplied .....	1-16
1-7	Accessories - Not Supplied .....	1-16
1-8	Safety Symbols .....	1-16
2-1	BOP 2X-D Front Panel Terminations and Controls .....	2-1
2-2	BOP Rear Panel Terminations and Controls .....	2-2
2-3	Chassis Slide Mounting Holes .....	2-5
4-1	Internal Adjustments and Calibrations .....	4-1
4-2	Suggested Sense Resistors .....	4-3



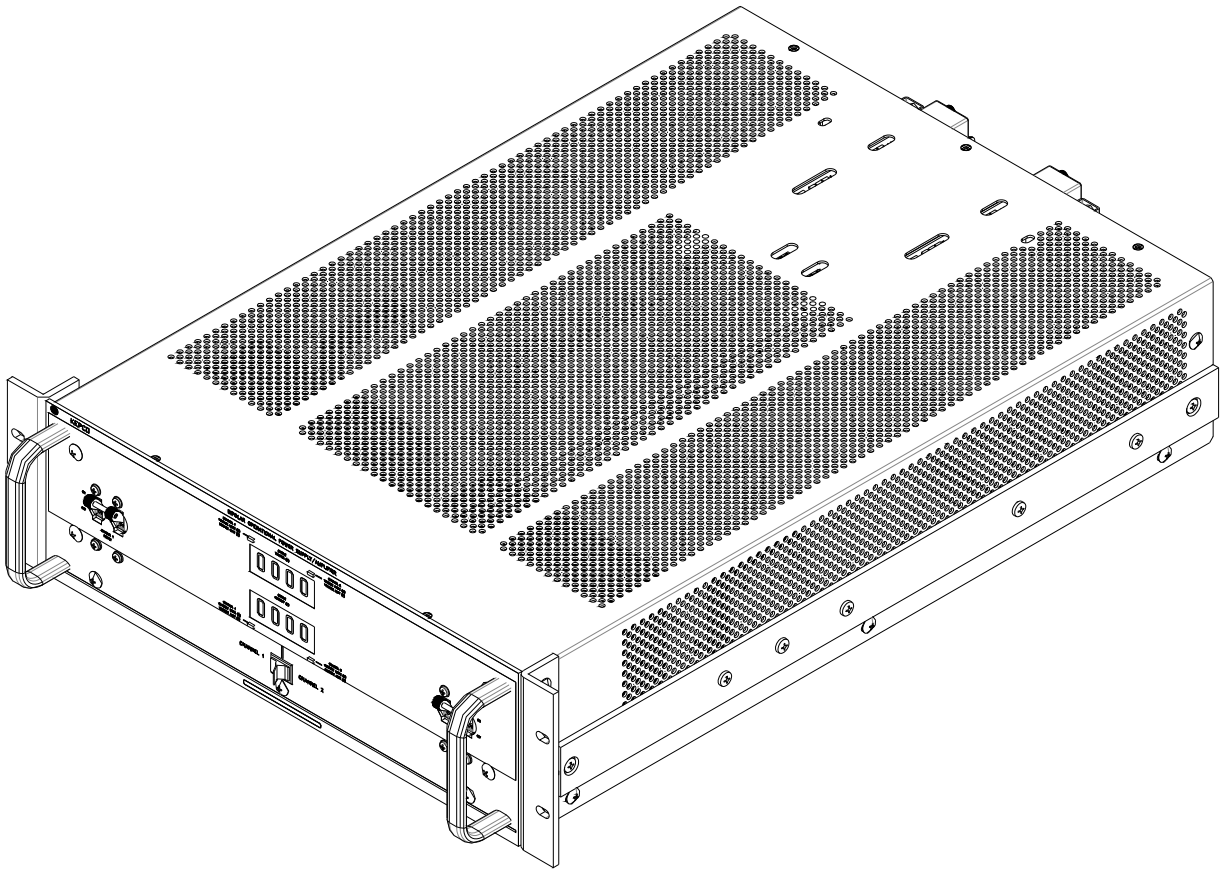

3044289

**FIGURE 1-1. BOP 2X-D SERIES 200W, 400W DUAL CHANNEL POWER SUPPLY**



## SECTION 1 - INTRODUCTION

### 1.1 SCOPE OF MANUAL.

This manual contains instructions for the installation and operation of the BOP 2X-D Dual Channel Series of 200, and 400 Watt Bipolar Operational Power supplies manufactured by Kepco, Inc., Flushing, New York, U.S.A.

Throughout this manual  $E_O$  represents the rated output voltage, and  $I_O$  represents the rated output current as defined by  $E_O$  MAX and  $I_O$  MAX, respectively in Table 1-3 for each model.

References in this manual to "BOP" apply to either Channel 1 or Channel 2. The two channels are functionally identical. References to "BOP 2X-D" apply to the full rack chassis containing the two separate channels.

### 1.2 OPTIONS

BOP 2X-D options are described below.

**1.2.1 METERS (D SUFFIX):** D suffix models are standard, and include two digital meters on the front panel used to display voltage and current for the channel selected by the Channel 1/Channel 2 select switch.

**1.2.2 CAPACITIVE LOAD OPTIMIZATION (C SUFFIX):** Models with a C suffix have been modified to be stable handling capacitive loads up to 10mF. A Modification Sheet describing changes and modified specifications can be downloaded from the Kepco web site at:  
[www.kepcopower.com/support/opmanls.htm#bop](http://www.kepcopower.com/support/opmanls.htm#bop).

**1.2.3 INDUCTIVE LOAD OPTIMIZATION (L SUFFIX):** Models with an L suffix have been modified to be stable handling inductive loads up to 1 Henry. A Modification Sheet describing changes and modified specifications can be downloaded from the Kepco web site at:  
[www.kepcopower.com/support/opmanls.htm#bop](http://www.kepcopower.com/support/opmanls.htm#bop).

**1.2.4 DIGITAL CONTROL (LAN) (E SUFFIX):** Models with an E suffix have two factory-installed BIT 802E cards that allow digital control of each channel via LAN using a web browser. Operation of E suffix models are covered by a separate BOP 2X-DE (C)(L) Operator Manual (P/N 243-1405) that can be downloaded from the Kepco web site at:  
[www.kepcopower.com/support/opmanls.htm#bop](http://www.kepcopower.com/support/opmanls.htm#bop).

NOTE: This manual is not valid for E suffix models **EXCEPT** if the associated BIT card has been disabled as described in a BOP Application Note: How to Disable a BIT card in BOP models with BIT 802E or 4886 cards installed or in BOP 2X-DE Models. The application note can be downloaded from the Kepco web site at:  
[www.kepcopower.com/support/bop-app-note.htm](http://www.kepcopower.com/support/bop-app-note.htm).

### 1.3 GENERAL DESCRIPTION.

Kepco's Series BOP 2X-D dual-channel BOP models are 200W and 400W power supplies. Each channel is a separate power supply, completely isolated, independent and functionally identical. The 200W units have two 100W channels and the 400W units have two 200W channels. Dual channel models come in a single full rack chassis capable of mounting in a standard 19-inch wide rack. The channels are completely isolated, but share two digital front panel meters (without affecting isolation) which display output voltage and current for the channel

selected by the front panel Channel select switch. A single power cord powers both channels; separate on-off circuit breakers turn each channel on/off separately.

Each channel of Kepco Series BOP 2X-D are fully dissipative, linear stabilizers for laboratory and systems applications. The BOP is an all solid-state design, featuring IC operational amplifiers in the control circuit section and silicon power transistors mounted on special fan-cooled heat sinks in the complementary power stage.

Each BOP channel is a linear stabilizer with two bipolar control loops (voltage or current mode), selectable and individually controllable by remote signals applied to the PC15 programming connector at the rear panel. These two principal control loops are each protected by bipolar limit circuits. The positive and negative current or voltage limit points can be remotely programmed simultaneously or Individually. Automatic crossover between each principal control loop and the limit loops is provided. Only one principal loop (voltage or current) can control the output at any one time.

All control and limit loops are connected to the complementary output stage via an EXCLUSIVE OR gate, so that only one main loop, either voltage or current, and one of the limit loops is in control of the BOP output at any one time. The BOP output can be programmed over its full output range by a  $\pm 10$  volt signal applied to the Rear Programming Connector as described in Section 3 of this manual. The limit control loops can be controlled by 0 to +10 volt signals as described in Section 3 of this manual. Without any remote limit control applied to the Rear Programming Connector the limits are set to approximately 110% of  $E_O$  MAX and  $I_O$  MAX.

Two preamplifiers, with both inverting and non-inverting inputs available at the Rear Programming Connector, can scale any programming source to the required internal control levels of the main loop. Zero adjustments for both preamplifiers are provided. By default the preamplifiers are set to an inverting configuration.

The BOP is a fast programmable power supply. The dynamic specifications for each channel, given in Table 1-3, are valid for resistive loads.

#### 1.4 ELECTRICAL SPECIFICATIONS, GENERAL

See Table 1-1 for general specifications. These specifications apply to each BOP channel except where indicated as applying to BOP 2X-D, referring to the entire chassis comprised of two BOP channels.

**TABLE 1-1. GENERAL SPECIFICATIONS**

SPECIFICATION	RATING/DESCRIPTION <sup>(1)</sup>	CONDITION/COMMENT
Input Voltage (Nominal)	104/ 115/ 208/ 230Vrms	Tolerance: $\pm 9\%$ Internal setting for the nominal input
Input Brown-out Voltage	Max 103.5Vrms	@ 115V/60Hz, Sourcing nominal output power
Input Frequency (Nominal)	50/ 60Hz	Tolerance: $\pm 3\text{Hz}$
Input Specifications	Input current, input power (active), power factor and efficiency differ by model.	See Table 1-2.
Input Leakage Current	50uArms	@ 115V/ 60Hz, Sourcing nominal output power
(1) Specifications listed for ambient temperature = 20°C and apply to each BOP channel unless otherwise specified.		

**TABLE 1-1. GENERAL SPECIFICATIONS (CONTINUED)**

SPECIFICATION	RATING/DESCRIPTION <sup>(1)</sup>	CONDITION/COMMENT
Insulation Coordination	Installation Cat. 2 Over-voltage Cat. 2 Pollution Degree 2	Maximum 250V DC or PK between COM output terminal and chassis-ground
Type Of Stabilizer	Voltage-Current, 4-quadrant	
Topology	Linear, Half Bridge	Class AB
Output Voltage	0 to $\pm E_{Omax}$ (Volts DC or peak)	See Table 1-3 for $E_{Omax}$ values.
Output Current	0 to $\pm I_{Omax}$ (Amperes DC or peak)	See Table 1-3 for $I_{Omax}$ values.
Output Power (Nominal)		For long term operation in sink, reduce the complementary limit settings to half of nominal. See Table 1-3 for nominal output power values.
Source Mode	$E_{Omax} \times I_{Omax}$ (Watts DC or peak)	
Sink Mode	$(E_{Omax} \times I_{Omax})/2$ (Watts DC or peak) <sup>(2)</sup>	
Output OFF/disabled level		The output OFF level can be calibrated using trim pots accessible from the top cover (see PAR. 4.3.8).
Voltage Mode	$0V \pm(0.01\%)(E_{Omax})V$	
Current Mode	$0A \pm(0.01\%)(I_{Omax})A$	
Voltage, Analog Programming (V.Mode)		
DC Transfer Factor	$(-E_{Omax}/10)$ V/V (default), it can be changed thru rear programming connector to $(+E_{Omax}/10)$ V/V	Install components on rear programming connector for a different preamp transfer factor.
Linearity	0.005% of $E_{Omax}$	Use rear programming connector to configure non-inverting operation.
FS Tolerance	2% of $E_{Omax}$ with the default preamplifier's network, or 0.02% when using external 0.01% matched pair resistors for the preamplifier	There is no internal calibration for the transfer factor in voltage mode.
Output Impedance	Model dependent	See Table 1-3 for default d-c transfer factor and output impedance values.
Voltage Static Specifications (V.mode)		
Source effect	0.001% of $E_{Omax}$	Input voltage = nominal $\pm 9\%$
Load effect	0.002% of $E_{Omax}$	No load to $(1.05 \times E_{Omax})/I_{Omax}$
Time effect (8h)	0.01% of $E_{Omax}$	After 30 minutes of conditioning
Temp. coefficient	0.01% of $E_{Omax}/^{\circ}C$	Averaged for the operating temperature range.
Ripple & noise (rms)	the greater of 0.01% of $E_{Omax}$ or 3mV	
(2) Output power - Sink mode for BOP 5-20 = $E_{Omax} \times I_{Omax}$ (DC or peak).		

**TABLE 1-1. GENERAL SPECIFICATIONS (CONTINUED)**

SPECIFICATION	RATING/DESCRIPTION <sup>(1)</sup>	CONDITION/COMMENT
Current, Analog Programming (C.mode)		
DC Transfer Factor	$(-I_{Omax}/10)A/V$ (default), it can be changed thru rear programming connector to $(+I_{Omax}/10)A/V$	Install components on rear programming connector for a different preamp transfer factor.
Linearity	0.02% of $I_{Omax}$	Use rear programming connector to configure non-inverting operation.
FS Tolerance	0.02% of $I_{Omax}$	Transfer factor in current mode has an internal calibration.
Output Impedance	Model dependent	See Table 1-3 for d-c current transfer factor and output impedance values.
Current Static Specifications (C.mode)		
Source effect	0.005% of $I_{Omax}$	Input voltage = nominal $\pm 9\%$
Load effect	0.05% of $I_{Omax}$	Short circuit to $(0.95 \times E_{Omax})/I_{Omax}$
Time effect (8h)	0.02% of $I_{Omax}$	After 30 minutes of conditioning
Temp. coefficient	0.02% of $I_{Omax}/^{\circ}C$	Averaged for the operating temperature range.
Ripple & noise (rms)	0.03% of $I_{Omax}$	
Analog Programming Type		
Voltage Source	0 to $\pm 10V$ (default) Inverting (default) or Non-inverting	Uses $\pm 10V$ reference applied to Preamp A for voltage mode and Preamp B for current mode via the Rear Programming Connector (see Section 3 for application schematics). Contact factory for preconfigured rear programming connector adapted to specific applications.
Current Source	Contact factory for details	
External Resistance	10K Ohms (default)	See Section 3 for application schematics.
Output ON-OFF (enable-disable) Control	Non-isolated 15V-CMOS signal at rear programming connector (see Table 1-5, pin 21 for details)	
Voltage Mode/Current Mode Control	Remote TTL non-isolated signal at rear programming connector (see Table 1-5, pin 30 for details)	
Calibration	Using trim-pots.	
Dynamic Specs (V.mode and C mode)	Model dependent	See Table 1-4
Special Dynamic Configurations		
Main loop bandwidth reduction	Possible, with changes at rear programming connector, for voltage and/or current	
Optimized for inductive loads	Models with L suffix	
Optimized for capacitive loads	Models with C suffix	

**TABLE 1-1. GENERAL SPECIFICATIONS (CONTINUED)**

SPECIFICATION	RATING/DESCRIPTION <sup>(1)</sup>	CONDITION/COMMENT
Voltage/Current Limits (Pos & Neg)  Analog-remote adjustment range	0.2 to 110% of nominal output, using 0V to +10V programming. voltage applied to rear programming connector,	Symmetrical or independent (positive or negative) control. See Section 3 for application schematics.
Analog Readback For Voltage and Current  Range	0 to ±10V, for 0 to ± nominal output	The analog readback signals are available at the rear programming connector.
Full Scale tolerance	0.02% of nominal monitoring output (10V)	
Accuracy	0.1% of nominal monitoring output (10V)	
Max current	1mA	
Kelvin Connection (remote error sensing)	Possible, with max 0.5V/ wire <sup>(3)</sup>	
Local Output Monitoring Type	Two Digital Panel Meters (D suffix models), one each for output voltage and current	Front panel switch allows meters to show voltage/current for Channel 1 or 2.
Accuracy	±(0.2% of full scale +2 counts) <sup>(5)</sup>	
Reference Voltages		Reference voltages can be used for external analog remote control schemes (see Section 3). They have internal calibration pots.
Value	+10V, -10V	
Tolerance	±1mV	
Load Current	4mA max.	
Source Effect	0.0005%	Input voltage: nominal ±9%
Load Effect	0.0005%	No load - full load
Time Effect	0.005%	8 hours after 1/2 hour conditioning
Temp. Coefficient	0.005%/°C	Averaged for the operating temperature range.
Front Panel Lights  Channel 1, Channel 2	VOLTAGE MODE/VOLTAGE LIMIT <sup>(4)</sup>	Lit green when in Voltage mode Lit yellow when in Voltage Limit mode
Channel 1, Channel 2	CURRENT MODE/CURRENT LIMIT <sup>(4)</sup>	Lit green when in Current mode Lit yellow when in Current Limit mode
<p>(3) For BOP 5-20D and BOP 5-30D: 0.25V/wire max.                      (4) Front panel lights always monitor both channel 1 and channel 2, regardless of channel selection for meter display.                      (5) E.g, for a channel rated at 100V, at rated output the digital voltmeter reads <math>100.0V \pm (0.002 \times 100 + 0.2)V = 100.0V \pm 0.4V</math>. For a channel rated at 20A, at rated output the digital ammeter reads <math>20.0A \pm (0.002 \times 20 + 0.2)A = 20.0A \pm 0.2A</math>.</p>		

**TABLE 1-1. GENERAL SPECIFICATIONS (CONTINUED)**

SPECIFICATION		RATING/DESCRIPTION <sup>(1)</sup>	CONDITION/COMMENT
Flag Signals  NOTE: All flags available at rear programming connector (see Table 1-5)	Voltage Mode	Active in when in voltage mode	TTL signal, active "L", non-isolated
	Current Mode	Active in when in Current mode	TTL signal, active "L", non-isolated
	Voltage Limit	Active in when in Voltage limit	TTL signal, active "L", non-isolated
	Current Limit	Active in when in Current limit	TTL signal, active "L", non-isolated
	Output On-off	Output on-off	Optocoupler transistor, saturated for output on, isolated. See Table 1-5, pin 46 for details.
BOP 2X-D Front and rear panel controls, indicators and terminals,		Front Panel: See Figure 2-1 and Table 2-1. Rear Panel: See Figure 2-2 and Table 2-2.	
Series Or Parallel Configurations of BOP channels	Type of connection	Master-Slave	
	Implementation	Configured by external wiring at rear programming connector	
Protections		(a) Input overcurrent, with 110% threshold (b) Heat-Sink overtemperature (c) Channels or Multiple units interlock (d) Input power loss	Trips Input circuit breaker. Tripping of the circuit breaker for input power loss can be disabled by a modification to the rear programming connector (see PAR. 3.5.2).
Temperature	Operating	0 to +55° C	BOP 2X-D
	Storage	-40 to +85° C	BOP 2X-D
Humidity		0 to 95% RH	BOP 2X-D, Non-condensing
Shock		20g/11ms/50% half sine	BOP 2X-D, Non-operating
Vibration	5-10Hz	10mm, double amplitude	BOP 2X-D, Non-operating
	10-55Hz	2g	
Altitude		Sea level to 10,000ft	BOP 2X-D, For operating temperature range
Cooling	Type	BOP 2X-D 200W, 400W: 1 fan per channel	Minimum 1U between stacked units.
	Air Flow	Front to rear	
	Air Intake	top, bottom, side	
Dimensions BOP 2X-D (200W, 400W)		5.22" H x 19" W x 26" D (132.6mm H x 482.6mm W x 558.8mm D)	
Weight	BOP 2X-D 200W (BOP 2X-D 400W)	80 lbs (36.3 kg) 90 lbs (40.8 kg)	Unpacked
Connections	BOP 2X-D Source	3-pin IEC connector	
	Load (power and sense) Grounding, GND network	Rear: 6-pin terminal block	
	Analog control	50-pin rear programming connector	

**TABLE 1-2. INPUT SPECIFICATIONS PER CHANNEL**

MODEL	INPUT CURRENT <sup>(1)</sup> (A)	ACTIVE INPUT POWER <sup>(1)</sup> (W)	POWER FACTOR <sup>(1)</sup>	EFFICIENCY <sup>(1)</sup> (%)
100 WATTS				
BOP 2X5-20D	4.7	460	0.84	22
BOP 2X20-5D	2.9	270	0.81	37
BOP2X 50-2D	2.9	270	0.81	37
BOP 2X100-1D	2.9	270	0.81	37
200 WATTS				
BOP 2X5-30D	6.4	640	0.87	24
BOP 2X20-10D	5.5	540	0.85	37
BOP 2X36-6D	5.1	490	0.84	44
BOP2X 50-4D	4.8	450	0.82	44
BOP 2X72-3D	5.1	470	0.80	46
BOP 2X100-2D	4.8	450	0.82	44
(1) Specifications listed are per channel for Input @ 115V, 60Hz sourcing nominal power.				

**TABLE 1-3. OUTPUT RANGES, TRANSFER FACTOR AND OUTPUT IMPEDANCE PER CHANNEL**

MODEL	DC OR PEAK <sup>(1)</sup> OUTPUT RANGES		DC OR PEAK <sup>(1)</sup> OUTPUT POWER		d-c CLOSED LOOP <sup>(1)</sup> GAIN		OUTPUT IMPEDANCE <sup>(1) (2)</sup>			
	E <sub>O</sub> MAX. V	I <sub>O</sub> MAX A	SOURCE W	SINK W	VOLTAGE CHANNEL G <sub>V</sub> (V/V)	CURRENT CHANNEL G <sub>I</sub> (A/V)	VOLTAGE MODE		CURRENT MODE	
							SERIES R mΩ	SERIES L mH	SHUNT R kΩ	SHUNT C μF
100 WATTS										
BOP 2X5-20D	0 to ±5	0 to ±20	100	100	0.5	2.0	0.01	0.004	5.0	0.3
BOP 2X20-5D	0 to ±20	0 to ±5	100	50	2.0	0.5	0.08	0.02	40	0.05
BOP 2X50-2D	0 to ±50	0 to ±2	100	50	5.0	0.2	0.5	0.1	50	0.05
BOP 2X100-1D	0 to ±100	0 to ±1	100	50	10.0	0.1	2.0	0.2	100	0.05
200 WATTS										
BOP 2X5-30D	0 to ±5	0 to ±30	150	75	0.5	3.0	0.01	0.004	5.0	0.5
BOP 2X20-10D	0 to ±20	0 to ±10	200	100	2.0	1.0	0.04	0.05	20	0.1
BOP 2X36-6D	0 to ±36	0 to ±6	216	108	3.6	0.6	0.12	0.05	36	0.1
BOP 2X50-4D	0 to ±50	0 to ±4	200	100	5.0	0.4	0.25	0.1	50	0.05
BOP 2X72-3D	0 to ±72	0 to ±3	216	108	7.2	0.3	0.48	0.2	72	0.05
BOP2X 100-2D	0 to ±100	0 to ±2	200	100	10.0	0.2	1.0	0.2	100	0.05
(1) Specifications listed are per channel.										
(2) Output impedance is for basic models with D suffix. For models with L or C options (DL or DC suffix) see applicable Modification Sheets available from Kepco's website at <a href="http://www.kepcopower.com/support/opmanIs.htm#bop">.http://www.kepcopower.com/support/opmanIs.htm#bop</a>										

**TABLE 1-4. OUTPUT DYNAMIC SPECIFICATIONS PER CHANNEL**

MODEL (1)	3dB BANDWIDTH (2) (3)		RISE & FALL TIME (2) (4)		SLEW RATE (2) (5)		RECOVERY AT STEP LOAD (2) (6)	
	KHz		10%-90% μsec		(average)		μsec	
	Mode		Mode		Mode		Mode	
	V	I	V	I	V V/μsec	I A/μsec	V	I
100 WATTS								
BOP 2X5-20D	11	5	40	70	0.2	0.46	40	100
BOP 2X20-5D	17	13	20	30	1.6	0.27	25	10
BOP 2X50-2D	17	13	20	30	4.0	0.11	25	10
BOP 2X100-1D	18	11	17	22	9.4	0.07	40	25
200 WATTS								
BOP 2X5-30D	12	7	30	54	0.27	0.9	50	80
BOP 2X20-10D	17	7	20	60	1.6	0.27	80	20
BOP 2X36-6D	15	14	23	27	2.5	0.61	50	35
BOP 2X50-4D	15	11	14	25	5.7	0.26	40	30
BOP 2X72-3D	17	12	18	26	6.4	0.18	30	30
BOP 2X100-2D	17	12	18	26	8.9	0.12	30	30
<p>(1) Dynamic specifications are for basic models with D suffix. For models with L or C options (DL or DC suffix) see applicable Modification Sheets available from Kepco's website at <a href="http://www.kepcopower.com/support/opman1s.htm#bop">http://www.kepcopower.com/support/opman1s.htm#bop</a></p> <p>(2) Specifications listed are per channel for Input @ 115V, 60Hz.</p> <p>(3) Represents 3-dB bandwidth for large sine signal for nominal resistive load/peak output voltage value @ 50Hz, equal to <math>E_{Omax}</math> in V mode and for short circuit/peak output current @ 50Hz, equal to <math>I_{Omax}</math> in I mode.</p> <p>(4) Represents the response timing of the pulsed output (@ 100Hz) for nominal resistive load/between <math>\pm E_{Omax}</math> in V mode and for short circuit/between <math>\pm I_{Omax}</math> in I mode.</p> <p>(5) Defined as the ratio between <math>(1.6)(E_{Omax})</math> or <math>(1.6)(I_{Omax})</math> and the corresponding rise/fall time for the same conditions described in Note (4) above.</p> <p>(6) Represents the 10-90% timing of a changing output when the load is switched between no load and nominal resistive load in V mode and between short circuit and nominal resistive load in I mode.</p>								

## 1.5 MISCELLANEOUS FEATURES

### 1.5.1 OUTPUT RANGE

Each BOP channel can be remotely programmed, from (-)100% to (+)100% of its specified d-c voltage and current range. The Class AB bipolar output stage permits operation as either a *source* or a *sink*. (See Figure 1-2).

NOTE: The BOP is operating as a *source* if the direction of its output voltage is the same as the direction of its output current. The BOP is operating as a *sink* if the direction of its output voltage is opposite that of its output current. An illustrative case is shown in Figure. 1-3, where the BOP is programmed to deliver a sine wave output and where the load produces a phase shift between the output voltage and current.



## 1.5.2 REAR PROGRAMMING FEATURES

The external Rear Programming Connector (See Table 2-2, Items 22 and 23 and Figure 3-27), is a 50-pin edge connector, providing access to all circuit features. The BOP 2X-D is delivered with two (2) PC 15 connectors, one for each channel, which are prewired with jumpers used for standard operating schemes as described in Section 3, while allowing the user to adapt the configuration to fit other application needs. Spare connectors may be purchased from Kepco under the model number PC 12 for the unwired connector and PC 15 for a generically wired connector. The functions of the Rear Programming Connector terminals are listed below in Table 1-5. Contact Kepco for Rear Programming Connectors prewired for specific functions described in Section 3.

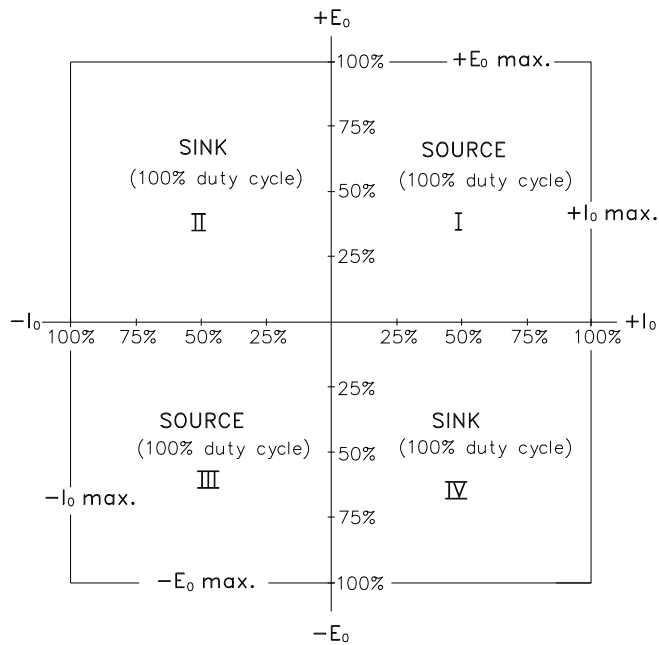

3043872

FIGURE 1-2. BOP CHANNEL OUTPUT CHARACTERISTIC

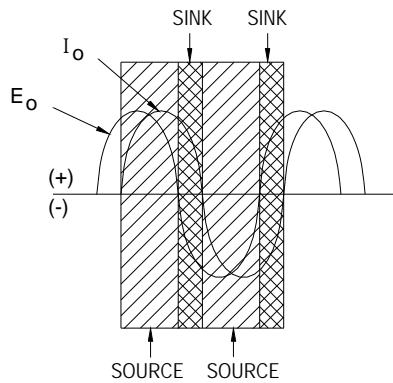

3043440

FIGURE 1-3. BOP OUTPUT WAVEFORMS WITH PHASE SHIFT

**TABLE 1-5. REAR PROGRAMMING CONNECTOR (1 PER CHANNEL)  
TERMINAL FUNCTIONS**

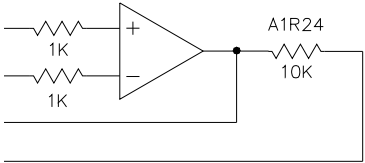
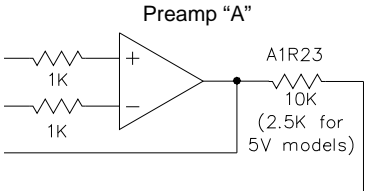
TERMINAL (Figure 3.2.2)	FUNCTION	DESCRIPTION
1	Current Limit Reference	Refer to PAR. 3.3.5
3	Voltage Limit Reference	Refer to PAR. 3.4.5
15 13 2 4	<p align="center">Preamp "B"</p> 	Refer to PAR. 3.4 for example.
11 9 5 7	<p align="center">Preamp "A"</p> 	Refer to PAR. 3.3.1 for example. NOTE: A1R23 = 2.5K for 5V models, 10K for all others
6	+E <sub>O</sub> Limit Input	Refer to PAR. 3.4.5
8	+I <sub>O</sub> Limit Input	Refer to PAR. 3.3.5
32	-E <sub>O</sub> Limit Input	Refer to PAR. 3.4.5
34	-I <sub>O</sub> Limit Input	Refer to PAR. 3.3.5
10	Current Monitoring	Analog output voltage (0 to ±10V, 1 mA max) proportional to the prevailing BOP output current for remote metering or monitoring.
20	Voltage Monitoring	Analog output voltage (0 to ±10V, 1 mA max) proportional to the prevailing BOP output voltage.
12, 14	Voltage Mode Compensating Terminals	Refer to PAR. 1.5.4
16, 18	Current Mode Compensating Terminals	Refer to PAR. 1.5.4
17	Voltage Comparison Amp Input	Analog input voltage of 0 to ±10V will produce 0 to ± full output voltage with unit set in voltage mode.
19	Current Comparison Amp Input	Analog input voltage of 0 to ±10V will produce 0 to ± full output current with unit set in current mode.
21	On-off Controlling Logic for the isolated on-off port, or Non-isolated on-off control	<p>Establishes whether TTL "1" or "0" applied to pin 50, referenced to pin 48 turns the output on or off.</p> <ul style="list-style-type: none"> <li>No signal (default) or "1" (15V CMOS): "0" = ON, "1" = OFF</li> <li>"0" or short to pin 23: "1" = ON, "0" = OFF</li> </ul> <p>NOTE: Pin 21 has a 15K Ohm pull-up resistor connected to the internal +15V bus.</p> <p>If no signal is applied between pin 50 and pin 48, pin 21 can be used as a non-isolated on-off control as follows:</p> <ul style="list-style-type: none"> <li>If Remote mode is not active (pin 35 not set to TTL "0"): <ul style="list-style-type: none"> <li>no signal or "1" (15V CMOS) = output ON</li> <li>"0" or short to pin 23 = output OFF</li> </ul> </li> <li>If Remote mode is active (pin 35 set to TTL "0"): <ul style="list-style-type: none"> <li>no signal or "1" (15V CMOS) = output OFF</li> <li>"0" or short to pin 23 = output ON</li> </ul> </li> </ul>
22	-10V Reference Voltage 4mA Max	Refer to PAR. 3.3.1 for examples.
28	+10V Reference Voltage 4mA Max	Refer to PAR. 3.3.1 for examples.

**TABLE 1-5. REAR PROGRAMMING CONNECTOR (1 PER CHANNEL)  
TERMINAL FUNCTIONS (CONTINUED)**

TERMINAL (Figure 3.2.2)	FUNCTION	DESCRIPTION
23, 25, 27, 29, 31, 33	Sensing Common	
24	Circuit Breaker Control	Refer to PAR, 3.5.2
26, 36	Turn-off Signal Output	Refer to PAR, 3.5.2
30	Voltage Mode/Current Mode control	Used to set either voltage mode or current mode (disables front panel MODE switch). For use only if a BIT card is not installed. Remote mode (pin 35) must be active to enable pin 30 and the output must be set to ON by connecting pin 21 to sensing common, pin 23. This disables the isolated Output ON-OFF Control at pin 50 and the isolated Output ON-Off flag at pin 46 and allows pin 21 to be used as non-isolated Output ON-OFF control (see pin 21 for Remote mode is active). <ul style="list-style-type: none"> <li>• Voltage mode = open or TTL "1"</li> <li>• Current mode = short (referenced to sensing common, pin 23) or TTL "0"</li> </ul>
35	Local/Remote control	Used to set either local or remote mode For use only if BIT card is not installed. Pin 35 must be set to Remote for pin 30 to be active. <ul style="list-style-type: none"> <li>• Local mode = open or TTL "1"</li> <li>• Remote mode = short (referenced to sensing common, pin 23) or TTL "0"</li> </ul>
37	+5V	Built-in TTL Logic supply, 5V @ 40mA max.
38	I <sub>O</sub> Limit Flag	Refer to PAR. 3-25
39	E <sub>O</sub> Limit Flag	Refer to PAR. 3-25
40	E <sub>O</sub> Mode Flag	Refer to PAR. 3-25
42	I <sub>O</sub> Mode Flag	Refer to PAR. 3-25
41	Non-isolated Turn-off Signal Input	Refer to PAR, 3.5.2
43, 44, 45	Not Used.	
46	/ON-OFF_FLAG	Flags whether output set to ON or OFF. This isolated flag signal is the open collector of an optocoupler-transistor, with the emitter connected to pin 48. Optocoupler transistor is saturated when the output is ON (enabled). Current through the transistor should not exceed 1.6mA and supply voltage should not exceed 24V. OFF level: determined by (Vext) - (Rext) (Icoff) where: Vext = External positive voltage Rext = Vext/1.6mA (External current-limiting resistor). Icoff = 0.0001mA (optocoupler transistor maximum dark current) The flag's rise time for either voltage mode with no load, or current mode with short circuit, is within 150μS max. ON level: +0.4V max. for 1.6mA current. The flag's fall time for either voltage mode with no load, or current mode with short circuit, is within 150μS max. NOTE This signal is disabled if the unit is set in current mode using pins 30 and 35.
47, 49	Optically Isolated Turn-off Signal Input	Refer to PAR, 3.5.2
48	ISO_GND	Return for ON-OFF_CTRL and for /ON_OFF_FLAG signals.

**TABLE 1-5. REAR PROGRAMMING CONNECTOR (1 PER CHANNEL)  
TERMINAL FUNCTIONS (CONTINUED)**

TERMINAL (Figure 3.2.2)	FUNCTION	DESCRIPTION
50	ON-OFF_CTRL	<p>Optically isolated signal that controls output to be either ON (enabled) or OFF (disabled). The logic of the control is established by pin 21 (see above).</p> <p>If pin 21 is not used (default status), the control levels for pin 50 are defined as follows:</p> <ul style="list-style-type: none"> <li>• ON control (default): 0V to 0.4V or no connection (open circuit) at pin 50, referenced to pin 48. Turns ON within 100<math>\mu</math>S max (between 10% point of controlling signal and a) 10% point of output voltage for voltage mode with no load or b) 10% point of output current for current mode with short circuit).</li> <li>• OFF control (default): 3.5V to 24V d-c at pin 50 referenced to pin 48; input current is 1mA <math>\pm</math>0.3mA. Turns OFF within 100<math>\mu</math>S max (between 90% point of controlling signal and a) 90% point of output voltage for voltage mode with no load or b) 90% point of output current for current mode with short circuit).</li> </ul> <p>If the BOP has a BIT card installed and active, the ON-OFF_CTRL and /ON-OFF_FLAG (pin 46) are disabled to allow the BIT card to control output on-off and monitor output on-off status.</p> <p>NOTE This signal is disabled if the unit is set in current mode using pins 30 and 35.</p>

### 1.5.3 REMOTE ON-OFF FEATURE

The output of the unit can be turned ON (enabled) or turned OFF (disabled) by using a non-isolated signal applied to the rear programming connector PC 15, pin 21 (referenced to pin 23, signal ground/common); see Table 1-5 for details. The isolated ON-OFF (pin 50 referenced to pin 48) is automatically disabled in BOP 2X-D models

If needed, the output OFF signal value is adjustable (see PAR. 4.3.8).

### 1.5.4 LOAD REACTANCE

#### 1.5.4.1 DRIVING AN INDUCTIVE LOAD IN CURRENT MODE

BOP power supplies with option L (L suffix) are optimized for driving large inductor loads. Factory tests were performed with loads up to 1H, however higher values are possible.

For basic units (without L suffix) when driving inductive loads higher than 0.5mH, the system may become unstable. There are two means of eliminating oscillation in the current loop operating with moderate inductive loads and moderate voltage and current:

1. Add capacitance in parallel with the output (inductive load). The value of capacitor can be from 0.1  $\mu$ F to 1.0  $\mu$ F depending on the value of the load inductance.
2. Add a series-connected resistor-capacitor network in parallel with the BOP output/inductive load. The value of resistor should be in the range of 100 to 500 Ohms and the value of capacitor should be 0.1  $\mu$ F to 0.5  $\mu$ F, depending on the load inductance value.

Both options are recommended when the BOP is used with very low frequency output into inductive loads.



**CAUTION:** When driving heavy inductive loads with high currents, it is possible for the BOP and the load to be damaged by an A-C input power loss which prevents the load's stored energy from being dissipated inside the BOP. To avoid possible damage from the inductance kick-back voltage observe the following:

- Use UPS to supply the BOP.
- Set BOP output current and/or voltage to zero and turn off the BOP after the output current actually reaches a zero value.
- Use properly rated (voltage and current) bipolar transorbs or a properly rated bipolar crowbar element connected directly at the output of the BOP. An alternative is a Normally-Closed Contactor connected across the output of the BOP that will be controlled open during normal operation. The coil of the contactor will be supplied from the same input power source as the BOP. These options may also be combined.

For both basic (without L suffix) and L suffix units, if the system becomes unstable at the cross-over between voltage limit mode and current mode when driving an inductive load, the power supply can be further optimized by reducing the current loop bandwidth. This can be accomplished by connecting a ceramic capacitor across pins 16 and 18 of the Rear Programming Connector (see Figure 3-27 and Table 1-5). The value of the capacitor is correlated to the load's inductance. A value in the range of 0.0022 $\mu$ F to 0.1 $\mu$ F is recommended.

#### 1.5.4.2 DRIVING A CAPACITIVE LOAD IN VOLTAGE MODE

BOP power supplies with option C (C suffix) are optimized for driving large capacitive loads (e.g., solar panels and solar cells). Factory tests were performed with loads up to 10mF, however higher values are possible.

For basic units (without C suffix) the system can become unstable when driving a capacitive load higher than 0.2 $\mu$ F in voltage mode. Install an external ceramic capacitor rated for 50V across pins 12 and 14 of the rear programming connector for stable operation. This capacitor will reduce the voltage loop bandwidth. The value of the capacitor is correlated to the load's capacitance. A value in the range of 0.0047 $\mu$ F to 0.47 $\mu$ F is recommended. This method can also be used for C suffix models if the system becomes unstable at the crossover between voltage mode and current limit mode.

#### 1.5.5 REMOTE TURN-OFF

Remote turn-off of the BOP, equivalent to tripping the front panel ON-OFF circuit breaker to OFF, can be accomplished by a contact closure, or by an optically isolated signal (see PAR. 3.5.2).

#### 1.5.6 CIRCUIT BREAKER SHUTDOWN PREVENTION (AT POWER LOSS) CIRCUIT

See PAR. 3.5.2.

#### 1.5.7 REFERENCES

Two reference/bias sources ( $\pm 10$ V at 4 mA max.) are provided for control and biasing purposes. These reference sources are available at the rear programming connector (with reference to the "COMMON" terminal).

### 1.5.8 SERIES OR PARALLEL OPERATION

See PAR. 3.5

### 1.5.9 EXTERNAL VOLTAGE MONITOR

Use signal  $E_O$  Monitor Output at pin 20 of the rear programming connector (see Figure 3-27) for external voltage monitoring (see PAR. 3.2.5 for details).

### 1.5.10 EXTERNAL CURRENT MONITOR

Use signal  $I_O$  Sensing Output at pin 10 of the rear programming connector (see Figure 4-5) for external current monitoring (see PAR. 3.2.6 for details).

### 1.5.11 MODE SETTING

Pin 30 of the Rear Programming Connector selects bipolar voltage or bipolar current control (see Table 1-5). Do not use pin 30 for voltage/current mode control if an optional BIT card for digital control of the channel is installed.

### 1.5.12 VOLTAGE CONTROL LOOP

The Bipolar Voltage Amplifier, with a fixed gain (See Table 1-3 for default gain value) is available at the Rear Programming Connector for remote control of the output voltage. A Zero  $E_O$  offset trimpot is provided for calibration of the voltage loop. Refer to applicable Service Manual for calibration of trimpots. Control methods are described in PAR. 3.3. The simplest method of controlling output voltage is shown in Figure 3-1.

### 1.5.13 CURRENT CONTROL LOOP

The Bipolar Current Amplifier, with a fixed gain (See Table 1-3 for default gain value) is connected to the Current Preamplifier and can be controlled by one of the schemes presented in Section 3. The simplest way is shown in Figure 3-3. The Current Preamplifier is provided with a Zero trimpot and all its terminals are available at the Rear Programming Connector for remote control of the output current. The current control loop has trimpots for current sensing amplifier Zero, and for the complete current loop Zero and full scale current calibration. Refer to applicable Service Manual for calibration of trimpots. Control methods are described in PAR. 3.4.

### 1.5.14 BOUNDING

Each BOP channel has four output voltage/current limiting circuits ( $-$   $E_O$  Limit,  $(+)$   $E_O$  Limit,  $(-)$   $I_O$  Limit and  $(+)$   $I_O$  Limit for overvoltage/overcurrent protection in either operating mode (refer to Figures 3-12, 3-13, 3-21, and 3-22). All four limits can be remotely controlled by means of 0 to 10 volt d-c control voltages applied to the rear programming connector (see Table 1-5, pins 6, 8, 32 and 34). The four limits may be remotely programmed independently, or the  $(\pm)$  voltage and  $(\pm)$  current limits can be controlled in pairs. Without any controlling signal applied to the rear programming connector the limits are set a default value of approximately 110% of  $E_O$  MAX and  $I_O$  MAX.

The four boundary quantities,  $(\pm) E_o$  max. Limit and  $(\pm) I_o$  max. Limit (shown in Figure 1-4) as applied to the Limit Channel, are actually about 10% greater than the rated values  $E_o$  max. and  $I_o$  max. for each BOP channel. To avoid uncertainty related to zero reference for multiple output control loops the minimum limit values are not zero. See Figure 1-4 for a graphic representation of boundaries and limits. See Table 1-1 for minimum limit values.

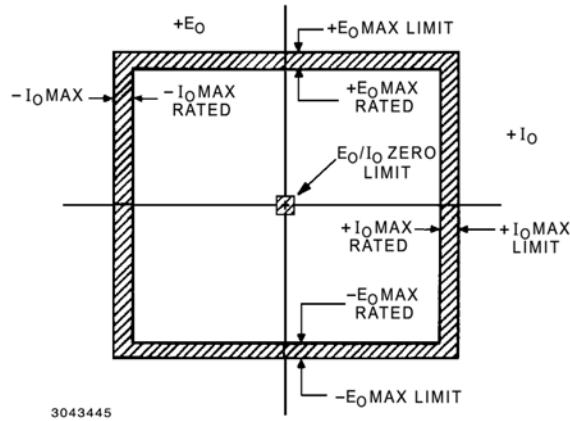

**FIGURE 1-4. BOUNDARIES AND LIMITS**

#### 1.5.15 MODE LIGHTS

Four (4) front panel (LED type) indicator lamps (two (2) for each channel) monitor the prevailing operating mode of the two BOP channels. These bicolor LEDs are always active, regardless of the position of the Channel 1/Channel 2 selector switch for meter displays. For each operating condition (Voltage Mode,  $\pm$ Voltage Limit, Current Mode,  $\pm$ Current Limit) the corresponding indicator lamp energizes: green for Voltage mode or Current Mode, yellow for Voltage Limit or Current Limit. Simultaneous TTL flags are available on the Rear Programming Connector (see PAR. 3-25).

#### 1.5.16 STANDARDS

BOP models are designed and tested in accordance with NEMA Standard for Stabilized Power Supplies, d-c output, Publication No. PY-1.1972.

#### 1.6 MECHANICAL SPECIFICATIONS

See Mechanical Outline Drawing, Figure 1-5 for dimensions and finish.

## 1.7 EQUIPMENT SUPPLIED

Equipment supplied is listed in Table 1-6.

**TABLE 1-6. EQUIPMENT SUPPLIED**

ITEM	PART NUMBER	QUANTITY
Rear Programming Connector (Local Control) - 50-terminal printed circuit connector for all rear programming connections and flag-signal outputs, wired for local (front panel) control of the BOP output.	PC 15	2
Power Cord, IEC connection to standard 115 VAC (USA),	118-0557	1
Mounting Flanges - for installation of the BOP into a standard (19 inch) equipment rack	Right	1
	Left.	1

## 1.8 ACCESSORIES

Accessories (not supplied) are listed in Table 1-7.



**TABLE 1-7. ACCESSORIES - NOT SUPPLIED**

ITEM	FUNCTION	KEPCO PART NUMBER
Rear Programming Connector, Unwired	50-terminal printed circuit connector, unwired, for access to all rear programming connections and flag-signal outputs.	PC 12
Slides	Ease of access to adjustments through top cover	110 QD (Jonathan)

## 1.9 SAFETY

Service must be referred to authorized personnel. Using the power supply in a manner not specified by Kepco, Inc. may impair the protection provided by the power supply. Observe all safety precautions noted throughout this manual. Table 1-8 lists symbols used on the power supply or in this manual where applicable.

**TABLE 1-8. SAFETY SYMBOLS**

SYMBOL	Meaning
	WARNING! RISK OF ELECTRIC SHOCK!
	CAUTION: REFER TO REFERENCED PROCEDURE.
WARNING	INDICATES THE POSSIBILITY OF BODILY INJURY OR DEATH.
CAUTION	INDICATES THE POSSIBILITY OF EQUIPMENT DAMAGE.



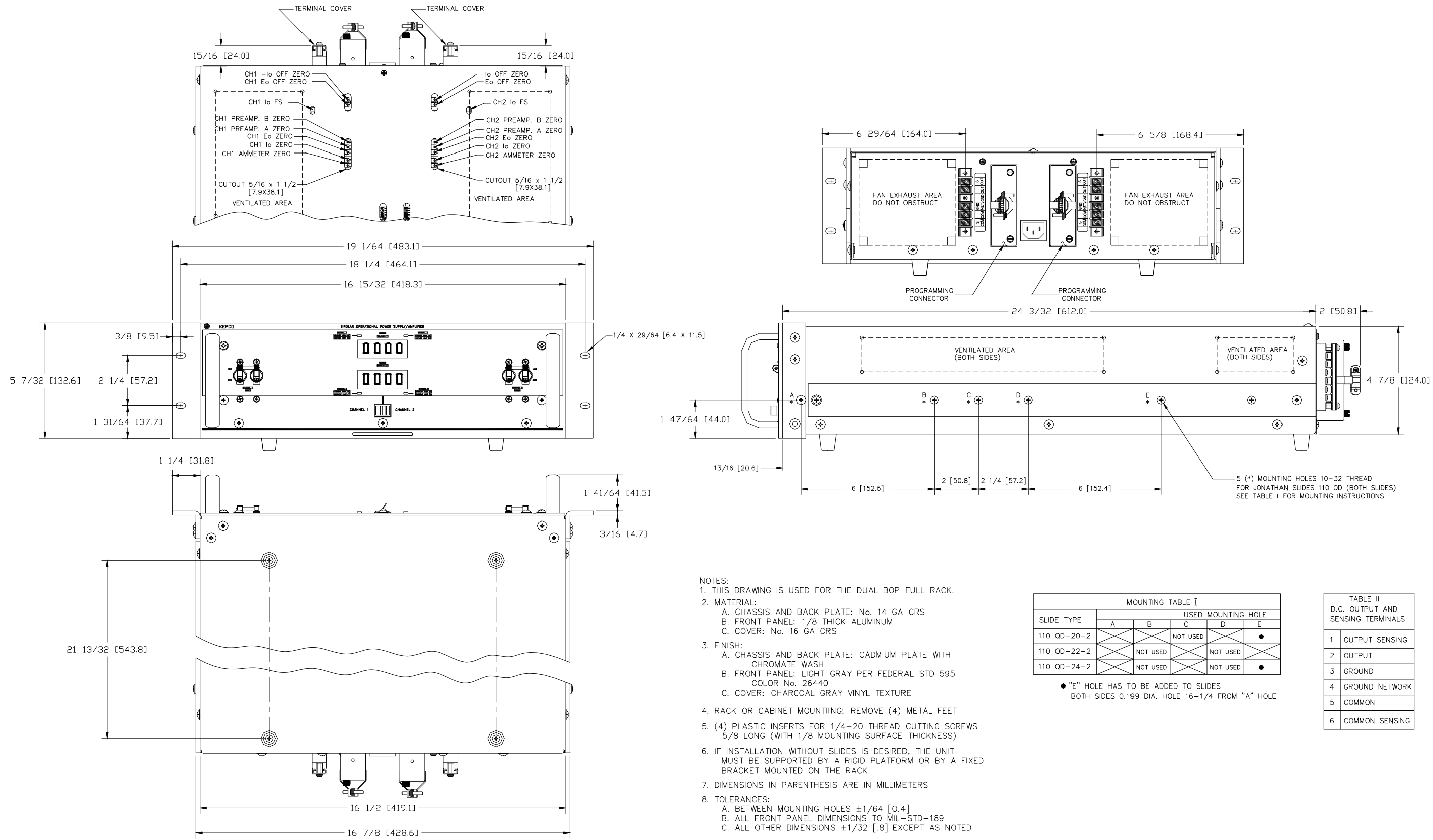

- NOTES:
- THIS DRAWING IS USED FOR THE DUAL BOP FULL RACK.
  - MATERIAL:
    - CHASSIS AND BACK PLATE: No. 14 GA CRS
    - FRONT PANEL: 1/8 THICK ALUMINUM
    - COVER: No. 16 GA CRS
  - FINISH:
    - CHASSIS AND BACK PLATE: CADMIUM PLATE WITH CHROMATE WASH
    - FRONT PANEL: LIGHT GRAY PER FEDERAL STD 595 COLOR No. 26440
    - COVER: CHARCOAL GRAY VINYL TEXTURE
  - RACK OR CABINET MOUNTING: REMOVE (4) METAL FEET
  - (4) PLASTIC INSERTS FOR 1/4-20 THREAD CUTTING SCREWS 5/8 LONG (WITH 1/8 MOUNTING SURFACE THICKNESS)
  - IF INSTALLATION WITHOUT SLIDES IS DESIRED, THE UNIT MUST BE SUPPORTED BY A RIGID PLATFORM OR BY A FIXED BRACKET MOUNTED ON THE RACK
  - DIMENSIONS IN PARENTHESIS ARE IN MILLIMETERS
  - TOLERANCES:
    - BETWEEN MOUNTING HOLES  $\pm 1/64$  [0.4]
    - ALL FRONT PANEL DIMENSIONS TO MIL-STD-189
    - ALL OTHER DIMENSIONS  $\pm 1/32$  [.8] EXCEPT AS NOTED

SLIDE TYPE	MOUNTING TABLE I USED MOUNTING HOLE				
	A	B	C	D	E
110 QD-20-2			NOT USED		●
110 QD-22-2		NOT USED		NOT USED	
110 QD-24-2		NOT USED		NOT USED	●

● "E" HOLE HAS TO BE ADDED TO SLIDES BOTH SIDES 0.199 DIA. HOLE 16-1/4 FROM "A" HOLE

TABLE II D.C. OUTPUT AND SENSING TERMINALS	
1	OUTPUT SENSING
2	OUTPUT
3	GROUND
4	GROUND NETWORK
5	COMMON
6	COMMON SENSING

FIGURE 1-5. MECHANICAL OUTLINE DRAWING, (BOP 2X-D SERIES MODELS)

3010323



## SECTION 2 - INSTALLATION

### 2.1 UNPACKING AND INSPECTION.

This instrument has been thoroughly inspected and tested prior to packing and is ready for operation. After careful unpacking, inspect for shipping damage before attempting to operate. Perform the preliminary operational check as outlined in PAR. 2.13. If any indication of damage is found, file an immediate claim with the responsible transport service.

### 2.2 TERMINATIONS, CONTROLS AND INDICATORS

- a) Front Panel: Refer to Figure 2-1. See Table 2-1 for an explanation of terminations, controls and indicators.
- b) Rear Panel: Refer to Figure 2-2 and Table 2-2 for an explanation of terminations.

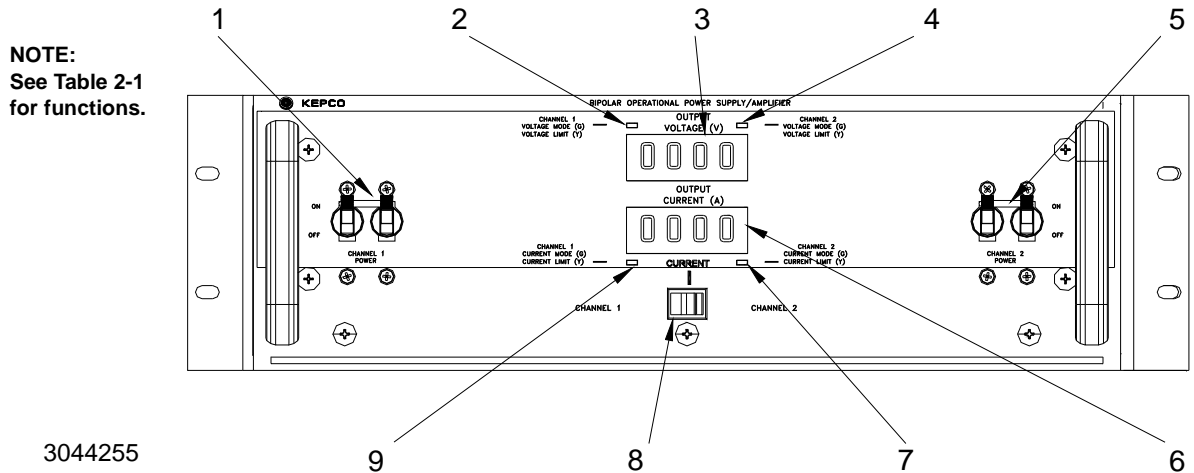

**FIGURE 2-1. BOP 2X-D TERMINATIONS AND CONTROLS, FRONT PANEL**

**TABLE 2-1. BOP 2X-D FRONT PANEL TERMINATIONS AND CONTROLS**

FIG. 2-1 INDEX NO.	NAME OF TERMINATION OR CONTROL	FUNCTION
1	A-C POWER circuit breaker for Channel 1	A-C circuit breaker/power switch for Channel 1
2	VOLTAGE MODE/ VOLTAGE LIMIT indicator for Channel 1	Lights green when channel 1 is in voltage mode. Lights yellow when channel 1 is in voltage limit.
3	VOLTAGE meter	Digital output voltmeter displays d-c output voltage in Volts for Channel 1 or Channel 2 as determined by Channel 1/Channel 2 selector switch
4	VOLTAGE MODE/ VOLTAGE LIMIT indicator for Channel 2	Lights green when channel 2 is in voltage mode. Lights yellow when channel 2 is in voltage limit.
5	A-C POWER circuit breaker for Channel 2	A-C circuit breaker/power switch for Channel 2

**TABLE 2-1. BOP 2X-D FRONT PANEL TERMINATIONS AND CONTROLS (CONTINUED)**

FIG. 2-1 INDEX NO.	NAME OF TERMINATION OR CONTROL	FUNCTION
6	CURRENT meter	Digital output current meter displays d-c output current in Amperes for Channel 1 or Channel 2 as determined by Channel 1/Channel 2 selector switch
7	CURRENT MODE/ CURRENT LIMIT indicator for Channel 2	Lights green when channel 2 is in current mode. Lights yellow when channel 2 is in current limit.
8	Channel 1/Channel 2 Meter select switch	Determines whether digital VOLT and CURRENT meters display output voltage and current, respectively, for Channel 1 or Channel 2.
9	CURRENT MODE/ CURRENT LIMIT indicator for Channel 1	Lights green when channel 1 is in current mode. Lights yellow when channel 1 is in current limit.

**TABLE 2-2. BOP REAR PANEL TERMINATIONS AND CONTROLS**

FIG. 2-2 INDEX NO.	NAME OF TERMINATION OR CONTROL	FUNCTION
1	REAR TERMINALS Channel 2	Rear barrier strip for channel 2 with output, output sensing, common, common sensing, grounding network and chassis ground terminals.
2	PC 15 for Channel 2	Rear Programming Connector for Channel 2. See Table 1-5 for details. NOTE: Unwired connector (PC 12) is available as an accessory (see Table 1-7).
3	P201	A-C power input jack accepts 3-wire line cord (supplied) to supply input power to both channels 1 and 2.
4	PC 15 for Channel 1	Rear Programming Connector for Channel 1. See Table 1-5 for details. NOTE: Unwired connector (PC 12) is available as an accessory (see Table 1-7).
5	REAR TERMINALS Channel 1	Rear barrier strip for channel 1 with output, output sensing, common, common sensing, grounding network and chassis ground terminals.

**NOTE:**  
See Table 2-2  
for functions.

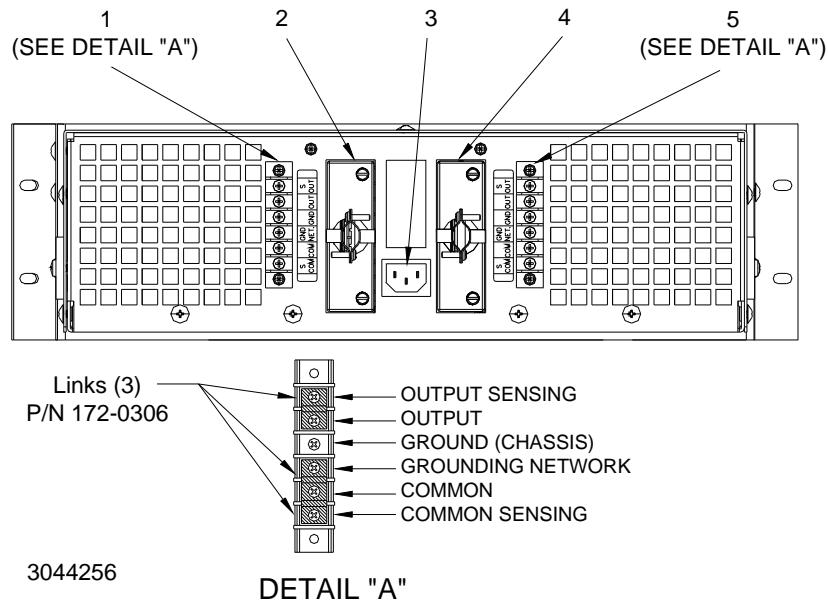

**FIGURE 2-2. BOP 2X-D TERMINATIONS AND CONTROLS, REAR PANEL**

### 2.3 A-C INPUT REQUIREMENTS

Each channel is shipped wired for operation on a single phase, nominal 115V a-c line. For operation on other a-c source voltages, refer to FIG. 2-3. Check your prevailing nominal source voltage and change the links on the barrier strip of main transformer T201 for both channel 1 and channel 2 according to the table provided in FIG. 2-3. The on-off circuit breakers for channels 1 and 2 remain equally effective at all input voltages.

**CAUTION: Both channels of the BOP 2X-D MUST be configured to use the same input voltage.**

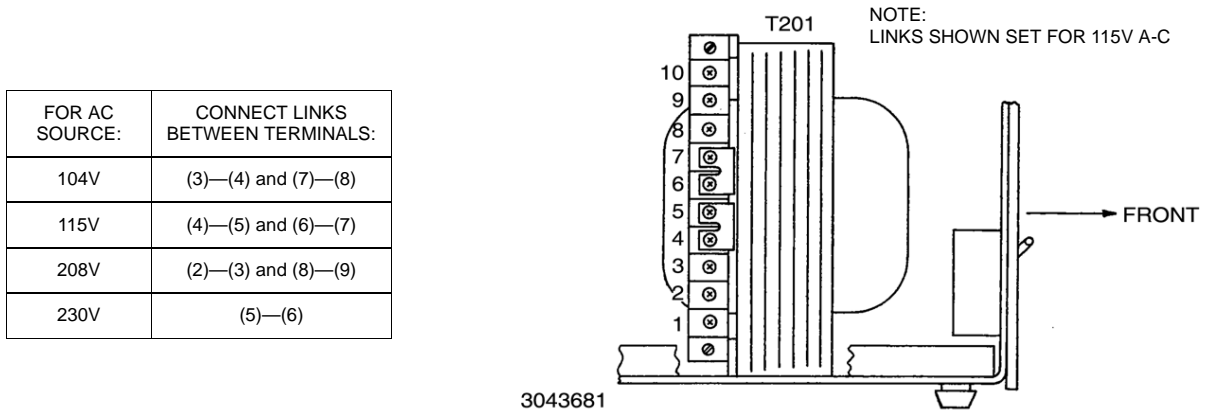

FIGURE 2-3. A-C SOURCE VOLTAGE SELECTION, EACH CHANNEL

### 2.4 COOLING

The components in the BOP power supply rely on forced air cooling for the maintenance of their operating temperature. Side panel openings and the top of the case must be kept clear from all obstructions to ensure air circulation. Periodic cleaning of the interior of the power supply is recommended. **If the BOP is rack-mounted or installed into confined spaces, care must be taken that the ambient temperature (the temperature immediately surrounding the power supply) does not rise above 55°C (~131°F).**

### 2.5 PRELIMINARY CHECKOUT



**CAUTION: The PC 15 connector must be connected for the unit to operate.**

A simple operating check after unpacking, and before permanent installation, is advisable to ascertain whether the BOP has suffered damage in shipment. Refer to Figures 2-1 and 2-2 and Tables 2-1 and 2-2 for the location and function of the operating controls and terminals. Proceed as follows for the channel under test:

1. Make the connections to the PC 15 rear panel programming connector as shown in Figure 3-1 for inverting voltage mode control and install at rear panel. This is required for local control of the unit, using a low impedance voltage programming source.
  - a. If installed, remove the connection between pins 30 and C of the PC 15.
  - b. Connect a 10K Ohm resistor (0.1%, 1/4W, metal film) to PC 15 pin 9.
  - c. Connect a ±10V programming voltage source between the unconnected end of the 10K Ohm resistor and PC 15 pin C.

- d. Use insulation tubing for the resistor leads and connections. Refer to Table 1-5 and Figure 3-27 for PC 15 details and signal allocations.
2. Set the CHANNEL 1 - CHANNEL 2 selector switch to the channel number under test..
3. Refer to PAR. 2.7.3 and connect unit to 115V a-c source (see PAR 2.3 for different source voltage).
4. Set the a-c POWER switch for channel under test to ON.
5. Adjust the external programming voltage between +10V and -10V while observing the front panel Voltmeter for the corresponding channel. The BOP output voltage should respond smoothly, from the maximum negative output voltage, through zero, to the maximum positive output voltage of the BOP. Verify that the VOLTAGE MODE/VOLTAGE LIMIT indicator for the corresponding channel is green (indicating Voltage Mode).
6. Leave -10V applied to the controlling input (see above) and apply voltage (3.5 to 24V) across pins 50 and 48 (return) of the PC 15 programming connector. Verify that front panel VOLTAGE and CURRENT meters for the channel under test show 0V and 0A, respectively, then disconnect voltage from PC 15 pins 50 and 48.
7. Set the a-c POWER switch for channel under test to OFF.
8. Connect a short circuit rated for the nominal output current between the OUTPUT and COMMON terminals at the rear panel of the channel under test.
9. At the rear panel of the channel under test, remove the PC 15 programming connector and make the connections to the PC 15 rear panel programming connector as shown in Figure 3-3 for inverting current mode control, then reinstall PC 15 at rear panel.
  - a. Install a wire jumper between pins 30 and C of the PC 15.
  - b. Connect a 10K Ohm resistor (0.1%, 1/4W, metal film) to PC 15 pin 13.
  - c. Connect a  $\pm 10V$  programming voltage source between the unconnected end of the 10K Ohm resistor and PC 15 pin C.
  - d. Use insulation tubing for the resistor leads and connections. Refer to Table 1-5 and Figures 3-27 for PC 15 details and signal allocations.
10. Set the a-c POWER switch for channel under test to ON.
11. Adjust the external programming voltage between +10V and -10V while observing the front panel Ammeter. The BOP output current should respond smoothly, from the maximum negative output current, through zero, to the maximum positive output current of the BOP. Verify that the CURRENT MODE/CURRENT LIMIT indicator for the corresponding channel is green (indicating Current Mode).
12. Leave -10V applied to the controlling input (see above) and apply voltage (3.5 to 24V) across pins 50 and 48 (return) of the PC 15 programming connector. Verify that front panel VOLTAGE and CURRENT meters for the channel under test show 0V and 0A, respectively, then disconnect voltage from PC 15 pins 50 and 48.
13. Set a-c POWER circuit breaker/ switch OFF. Remove the short circuit from the output terminals. This concludes the preliminary check-out for this channel. Repeat the above steps for the other channel.

**NOTE:** If an application requires that the output be OFF at power up and no signal (or logic 0) is to be applied to pin 50 referenced to pin 48 (isolated remote on-off control) of the rear programming connector, then connect a permanent jumper between pins 21 and C of the rear programming connector. With this jumper in place, a logic 1 must be applied to pin 50, referenced to pin 48, of the rear programming connector to enable the output. See Table 1-5 for details.

## 2.6 INSTALLATION OF BOP 2X-D SERIES MODELS

**NOTE:** For all installations into confined spaces, care must be taken that the temperature immediately surrounding the unit does not exceed the maximum specified ambient temperature (55° C).

Refer to the Mechanical Outline Drawing, Figure 1-5. BOP 2X-D Series models are delivered with the Fixed Angle Brackets and the Chassis Side Support Bars installed. For bench operation, both of these components may be removed.

The BOP 2X-D may be installed into standard (19-inch) equipment racks, or onto any other flat surface after removing the four (4) bottom aluminum feet. For rack installation of multiple units, 1U spacing is required between units.

If chassis slides are not used, the BOP 2X-D may be installed onto any flat surface by means of the provided plastic mounting inserts on the bottom of the BOP 2X-D chassis.

**NOTE:** If slide installation (as described below) is not desired, other means of supporting the unit in the rear must be provided (additional rear brackets or a solid platform, for example) since the front angle brackets alone are not sufficient to support the full weight of the unit.

### 2.6.1 SLIDE INSTALLATION.

The Chassis Slide Support Bars of the BOP 2X-D are pre-drilled to accept Jonathan Series 110 QD slides. The slides listed in Table 2-3 can be accommodated.

**TABLE 2-3. CHASSIS SLIDE MOUNTING HOLES**

MODEL	KEPCO P/N	MOUNTING HOLES USED				
		A	B	C	D	E
110 QD-20-2	108-0067	X	X	O	X	DR
110 QD-22-2	108-0156	X	O	X	O	X
110 QD-24-2	108-0192	X	O	X	O	DR
KEY: X = Hole Used O = Hole Not Used DR = Hole must be drilled into chassis part of slide, each side, 0.199 in. dia., 16-1/4 in. from "A" hole.						

To install the slides, refer to Figure 2-4 and proceed as follows:

1. Remove screws "A" through "E" from left and right chassis slide support bars. (Do not discard).
2. Determine the required hole-pattern for the selected slide model from Table 2-3.
3. Drill the "E" hole into both left and right chassis sections of slide if required.

4. Mount the chassis section of the slide to the left and right side of the BOP 2X-D as shown in Figure 2-4. Use the same 10-32 x 1/2" mounting screws removed in step 1.

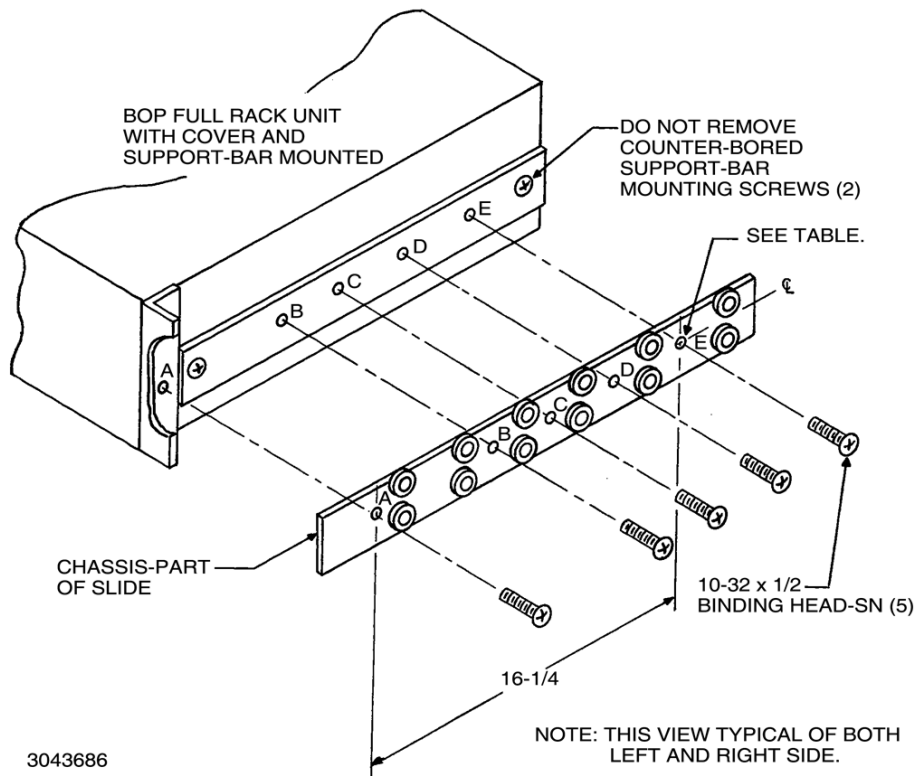

**FIGURE 2-4. SLIDE INSTALLATION ON BOP 2X-D UNITS**

## 2.7 LOAD CONNECTION

Load connections to each BOP channel are achieved via the OUTPUT and COMMON terminals located on the rear panel.

### 2.7.1 LOAD CONNECTION, LOCAL SENSING

The basic interconnections between a BOP channel and the load using local sensing are shown in Figure 2-5.

The load wire size for the 2-wire connection shown should be rated for the nominal output current of the BOP channel and tied together to keep parasitic inductance low and to reduce possible "pick-up" from stray magnetic fields. The basic 2-wire connection is useful where the voltage drop in the load wires is small or of minor consequence, as for example, operation in constant current mode.

### 2.7.2 LOAD CONNECTION, REMOTE SENSING

The basic interconnections between each BOP channel and the load using remote sensing are shown in Figure 2-6. This is the recommended load connection for all applications requiring min-



imum load effect across a remote load. A twisted or shielded pair of wires (No. 22 AWG minimum) are connected from the BOP sensing

**NOTE: The following explanation of AC and DC grounding can apply to any Kepco power supply even though this text applies specifically to BOP 2X-D Series.**

### 2.7.3 A-C GROUND

The metal cases of electronic equipment which are operated from the a-c power line must be kept at ground potential at all times. If the 3-wire line cord with 3-prong safety plug (supplied with this equipment) is used in combination with a properly grounded a-c power outlet, this is taken care of automatically. If a non-grounded outlet is used, the case must be earth-grounded separately. A separate GROUND terminal for each channel is provided for this purpose on the rear panel of the BOP 2X-D.

The GROUND terminal of each channel is connected to chassis of the unit and to the local earth-ground potential through the A-C power line cord. It can be used a) as a grounding point for the output of the unit (COMMON terminal), and b) for doubling the a-c power cord earth-ground connection if necessary by providing a separate connection to the local earth-ground point.

**CAUTION: Never connect a BOP output terminal (or the load terminal tied to the output terminal) to earth-ground. Otherwise, if the controlling device is grounded, the BOP channel can be damaged by the output limit current flowing inside the BOP along the programming signal return path.**

**CAUTION: Do not connect both the load and the programming device return (common) to earth-ground. Otherwise, if the common power connection between the BOP channel and the load is lost, the BOP can be damaged by output current flowing inside the BOP along the programming signal return path.**

**CAUTION: Do not use the programming return terminal as a tap point for the load return because the BOP can be damaged by output current flowing inside the BOP along the programming signal return path.**

In conclusion, if the application needs to have its common point tied to earth ground, make the common terminal to earth-ground connection for only ONE of the following: a) BOP channel in use, b) load, c) a device connected to the BOP output, d) a programming device.

### 2.7.4 D-C GROUND

Specified ripple and noise figures listed in Table 1-1 for operational power supplies apply to each channel and are valid only with the COMMON side of the output/load circuit returned to an earth-ground point as shown in Figures 2-5 and 2-6.



**CAUTION:** If the programming device return is tied to earth-ground, leave the BOP output floating. Otherwise, instability and inaccuracy will occur.

If the application requires, the COMMON of the BOP may be floated up to 250V d-c (or peak) off ground. For this case, due to the common mode noise current flowing through a higher impedance, the resulting ripple/noise will be larger than published specifications. If the application must be grounded, connect a single return/common point of the application (including programming device, BOP and load) to earth-ground. The exact location of the best return earth-ground point must be carefully selected for minimum ripple/noise output.

The GROUNDING NETWORK terminal is tied to GROUND (chassis) terminal through a series capacitor-resistor network. Connecting the GROUNDING NETWORK terminal to the COMMON terminal reduces common noise current flowing through the load.

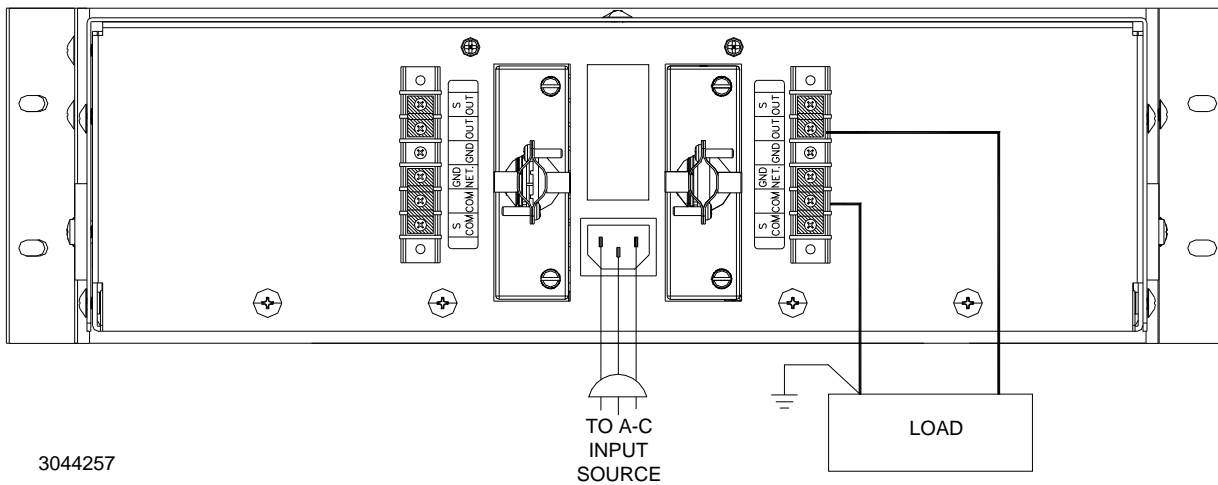

3044257

**FIGURE 2-5. LOAD CONNECTION (CHANNEL 1, TYP.) USING LOCAL SENSING**

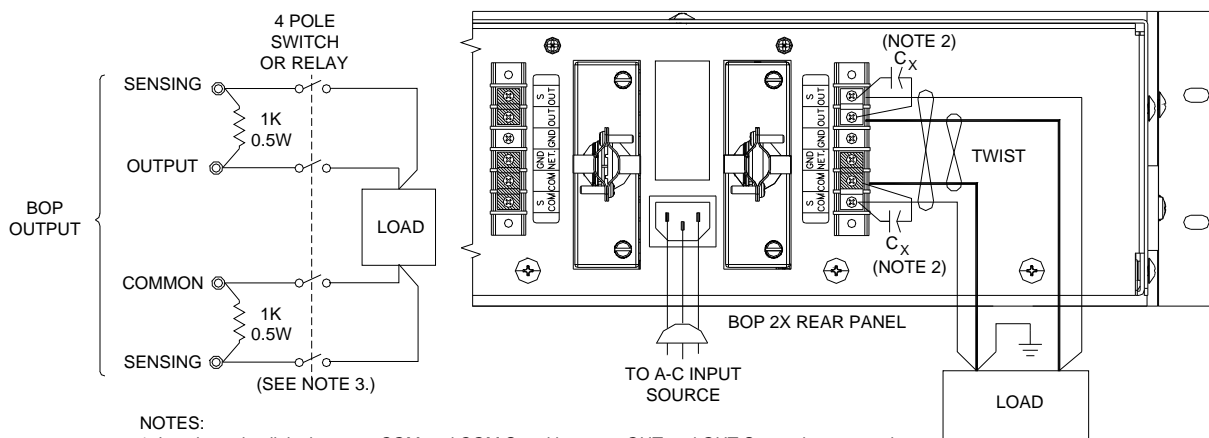

**NOTES:**

1. Local sensing links between COM and COM S and between OUT and OUT S must be removed.
2. For applications requiring very long connections, additional external capacitors ( $C_x$ ) should be connected as shown to compensate for the lead inductance of the connecting wires.
3. For applications requiring manually switched or relay driven output connections, external resistors must be connected as shown. All connections must be made and broken simultaneously.
4. Use separate properly rated twist pair wires for output power and output sensing connections.

3044258

**FIGURE 2-6. LOAD CONNECTION USING REMOTE SENSING**

## SECTION 3 - OPERATION

### 3.1 INTRODUCTION

Each channel of the BOP 2X-D Bipolar Operational Power Supply can be used in a great variety of applications. As a precision voltage or current source, the BOP output can be controlled remotely by means of resistance or voltage signals or an optional digital interface (see PAR. 3.42). Independently adjustable remotely programmable limit circuits for both output voltage and output current protect a sensitive load from any overvoltage or overcurrent.



**NOTE:** Before using the BOP in any application, please refer to Section 2 to get acquainted with the operating controls, a-c power requirements and information on load connections and grounding. Front panel components identified by index numbers in parentheses are shown in Figure 2-1.

### 3.2 POWER SUPPLY BASICS

As a Bipolar Amplifier, each BOP channel responds to such input signals as sine, square or triangular waves. A  $\pm 10$  volt input signal will program the BOP output (voltage or current) through its rated output ranges. Built-in preamplifiers, for the voltage, as well as the current loop of the BOP, permit amplification of the control signals to the required amplitude and provide the interface with high, as well as low, impedance signal sources.

Detailed examples of the more popular applications are described in the following paragraphs. Before actual operation, however, the following safety precautions must be carefully considered.



#### WARNING

**Exercise care in making all connections to and from the BOP terminals. Remove a-c power from the BOP 2X-D before making any connections.**

**Wires and/or cables connected from the BOP terminals to external components or programming devices must be properly insulated and securely terminated on both sides to make accidental touch impossible.**

**The BOP chassis must be safety-grounded to a reliable a-c source earth-ground. A safety-ground may be established by using a grounded a-c power outlet or, if the latter is not available, by means of a separate wire from the provided GROUND terminal for each channel to a reliable a-c source earth-ground point.**

**The COMMON output terminal of a BOP channel can be either grounded or floating, depending on the application. Additional precautions must be taken to make any user access to the output terminals impossible.**

**A BOP channel must always have sensing configured between OUT and OUT S and between COM and COM S. For voltage mode choose either local or remote sensing as desired. For current mode use local sensing.**

Application and test set up diagrams on the following pages show the symbolic and simplified representation of four basic programmable circuits of a BOP channel:

- Voltage Control Loop: see Figure 3-1 and PAR. 3.3.
- Current Limit Circuits: See Figure 3-2 and PAR. 3.3.5.
- Current Control Loop: see Figure 3-3 and PAR. 3.4.
- Voltage Limit Circuits: see Figure 3-4 and PAR. 3.4.5.

The complete simplified diagram is shown in Figure 3-26 at the end of this section. The four circuits can be programmed separately as described in the examples in this section. Of these four circuits, only three can be used at one time, voltage loop with current limit and voltage limit loops or current loop with current limit and voltage limit loops. However, most of the time either voltage loop current limit loop or current loop with voltage limit loop are being exercised. Figures 3-26 and 3-27 also show the complete wiring configuration of the unmodified (default) PC 15 Rear Programming Connector.

The main control loop (either voltage or current) can be selected by using pin 30 of the Rear Programming Connector, however do not use pin 30 for voltage/current mode control if an optional BIT card for digital control of the channel is installed.

- Voltage mode = open or TTL “1” (high)
- Current mode = short (referenced to sensing common, pin C) or TTL “0” (low)

### 3.2.1 PC 15 REAR PROGRAMMING CONNECTOR

PC 15 Rear Programming Connector MUST be installed in order for a BOP channel to function. The numbered pins in the simplified diagrams of this section correspond to the pins of the Rear Programming Connector PC 15. Modifications to the existing PC 15 connections are noted on the simplified diagrams for the application examples. The pin designated C (Common) corresponds to pin numbers 23, 25, 27, 29, 31 or 33 on the PC 15 Connector. See Figure 3-27 at the end of this section for additional details regarding the PC 15 rear programming connector.

Although schematically and functionally identical, there are some small differences in the physical connections for the two PC 15 versions, P/N 195-0039 which uses wire jumpers and P/N 195-0121 which uses printed circuit traces. Connections shown on the diagrams in this section are for P/N 195-0121. Wire jumpers may be used to make needed connections for both PC 15 versions.

- **Pins 1, 8, and 34:** wire jumpers use pin 1 as a tie point, with wire jumpers to pins 8 and 34. Printed circuit traces use pin 34 as a tie point, with printed circuit trace connections to pins 8 and 1.
- **Pins 3, 6, and 32:** wire jumpers use pin 32 as a tie point, with wire jumpers to pins 3 and 6. Printed circuit traces use pin 3 as a tie point, with printed circuit trace connections to pins 32 and 6.

### 3.2.2 EXTERNAL PROGRAMMING RESISTORS.

External programming resistors should be high-quality units, with low-temperature coefficients. Resistors should be selected carefully, since in most applications, the limitations for stability and drift are due not to the BOP, but to the programming resistors. Selection criteria for resistors are:

- Temperature coefficient
- Leakage (in values above 100k ohm)
- Humidity effects
- Drift with time
- Self-heating (power dissipation)
- Tolerance.

For variable resistors (potentiometers or rheostats) similar selection criteria apply. In addition, such specifications as listed below should be carefully considered if the application requires:

- End resistance
- Linearity
- Capacitive and inductive parasitic effects

### 3.2.3 ACTIVE PROGRAMMING SOURCES

External programming sources (Signal Generators, etc.) or reference sources should have temperature coefficients and drift specifications comparable to (or better than) the BOP 2X-D Power Supply.



**CAUTION: A-C source-operated programming sources must have their output isolated from the case.**

### 3.2.4 EXTERNAL LEADS

Shielded (preferably twisted) lead pairs are recommended for all input connections to the BOP control loops of each channel. The shield should be connected (single-ended) to the chosen signal ground point. Shielded leads should be held as short as practicable. Output leads must be voltage-rated for at least the maximum BOP output voltage and current. Twisted pair wires are recommended for output power and output sense wiring.

### 3.2.5 EXTERNAL VOLTAGE MONITOR

Use Voltage Monitoring signal at pin 20 of the Rear Programming Connector. The range of this signal is 0 to  $\pm 10V$  equivalent to output voltage of 0 to  $\pm E_{Omax}$ . The Voltage Monitoring signal is buffered by an op-amp. This stage is protected against short-circuit by the intrinsic protection of the op-amp. The return for the Voltage Monitoring signal is referred to as pin C, and can be any one of the signal return (signal common) pins (23, 25, 27, 29, 31 or 33) of the rear programming connector.

### 3.2.6 EXTERNAL CURRENT MONITOR

Use the Current Monitoring signal at pin 10 of the Rear Programming Connector for external current monitoring. The range of this signal is 0 to  $\pm 10V$ , equivalent to output current of 0 to  $\pm I_{Omax}$ . An op-amp buffers the Current Feedback/Sensing signal in order to create the Current Monitoring signal. This stage is protected against short-circuit by the intrinsic protection of the op-amp generating this signal. The return for the Current Monitoring signal is referred to as pin C, and can be any one of the signal return (signal common) pins (23, 25, 27, 29, 31 and 33) of the rear programming connector.

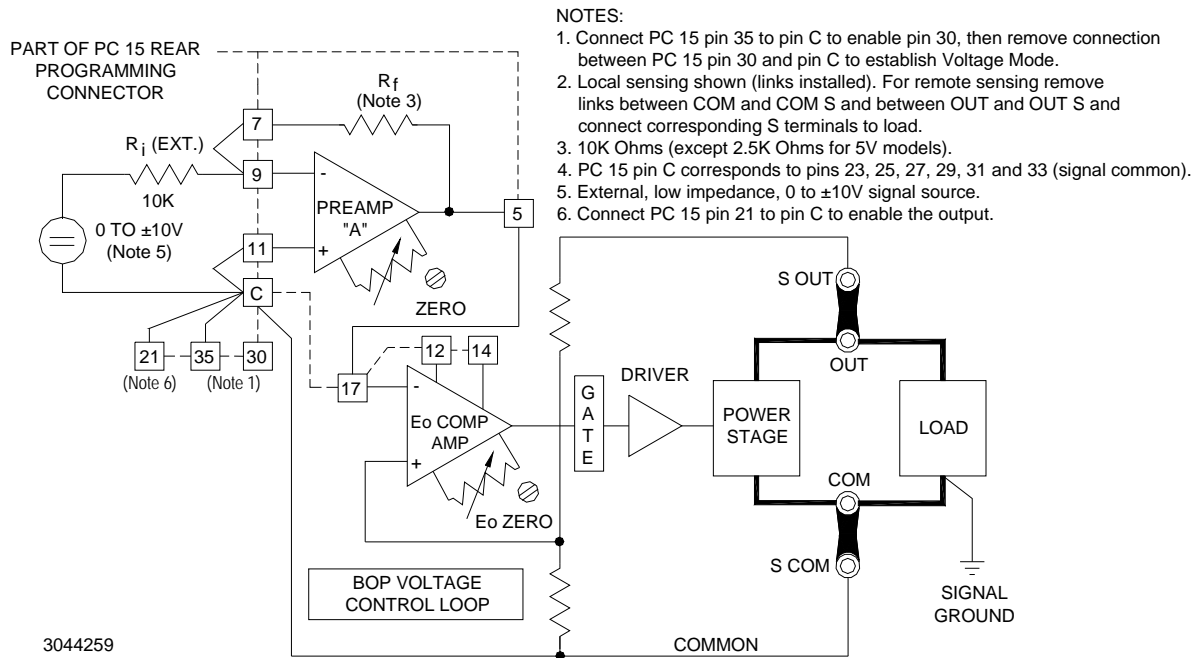

- NOTES:
1. Connect PC 15 pin 35 to pin C to enable pin 30, then remove connection between PC 15 pin 30 and pin C to establish Voltage Mode.
  2. Local sensing shown (links installed). For remote sensing remove links between COM and COM S and between OUT and OUT S and connect corresponding S terminals to load.
  3. 10K Ohms (except 2.5K Ohms for 5V models).
  4. PC 15 pin C corresponds to pins 23, 25, 27, 29, 31 and 33 (signal common).
  5. External, low impedance, 0 to  $\pm 10V$  signal source.
  6. Connect PC 15 pin 21 to pin C to enable the output.

FIGURE 3-1. BOP BASIC VOLTAGE CONTROL LOOP (LOCAL SENSING)

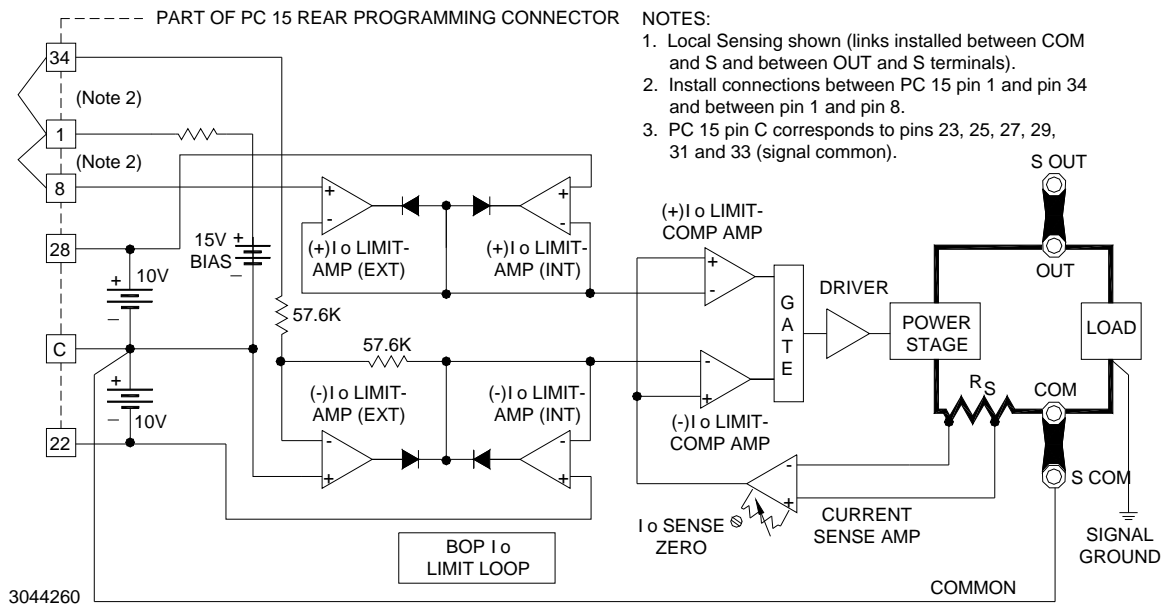

- NOTES:
1. Local Sensing shown (links installed between COM and S and between OUT and S terminals).
  2. Install connections between PC 15 pin 1 and pin 34 and between pin 1 and pin 8.
  3. PC 15 pin C corresponds to pins 23, 25, 27, 29, 31 and 33 (signal common).

FIGURE 3-2. BOP BASIC ( $\pm$ ) CURRENT LIMITING CIRCUIT (LOCAL SENSING)

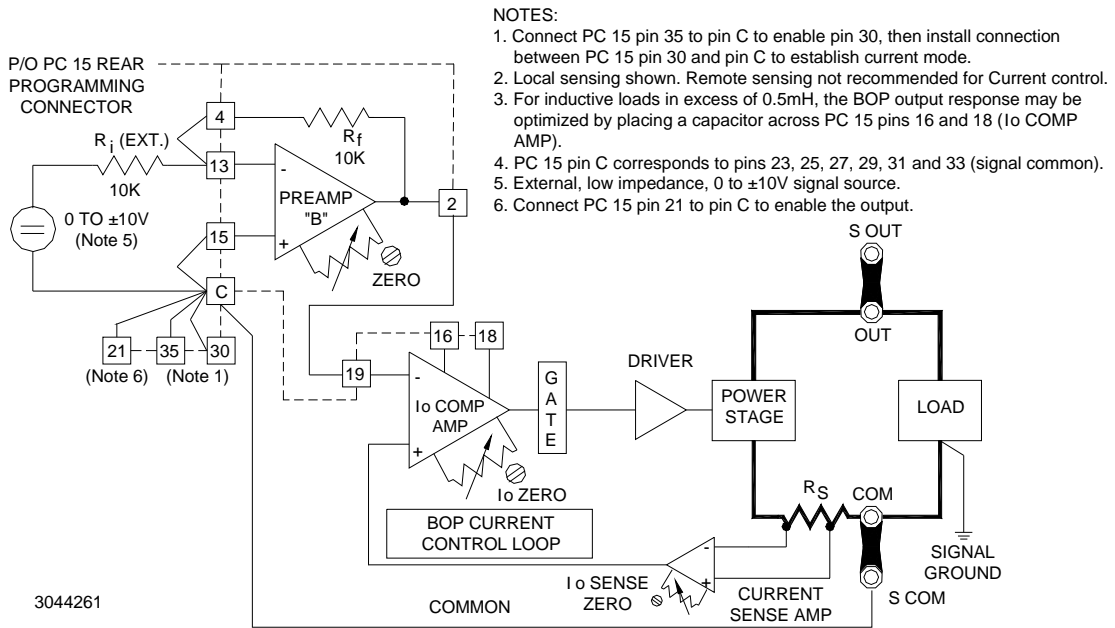

FIGURE 3-3. BOP BASIC CURRENT CONTROL (LOCAL SENSING)

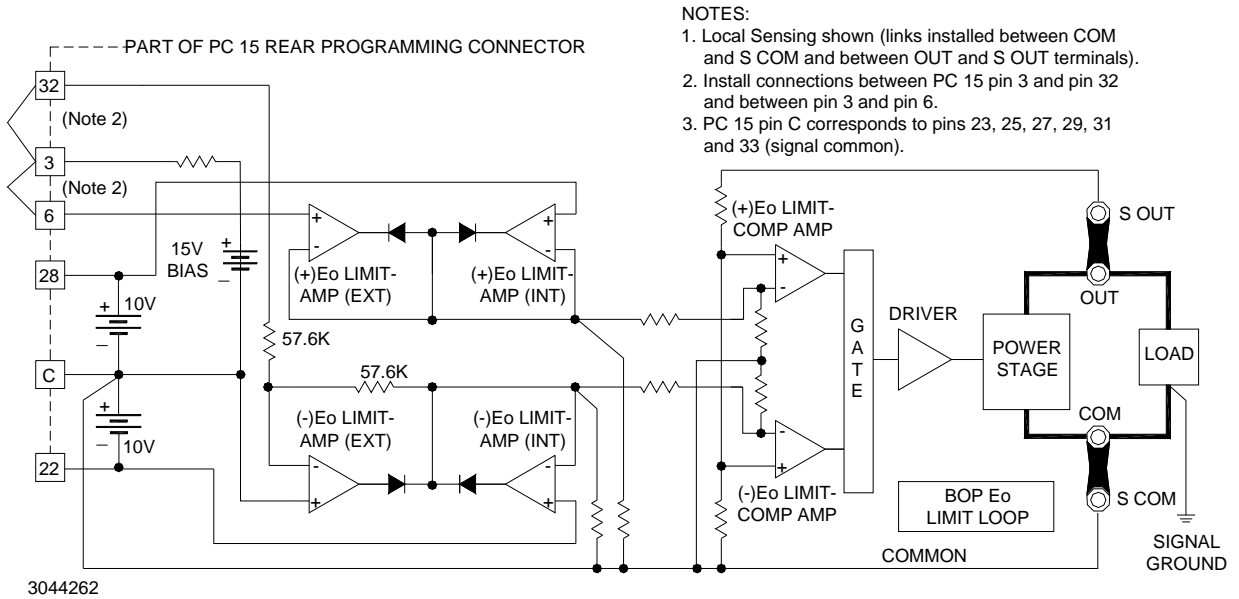

FIGURE 3-4. BOP BASIC (±) VOLTAGE LIMITING CIRCUIT (LOCAL SENSING)

### 3.3 REMOTE CONTROL OF VOLTAGE LOOP

Control of the voltage loop is accomplished by using an external configuration to apply control voltage(s) to the applicable pins of the PC 15 Rear Programming Connector.

#### 3.3.1 REMOTE VOLTAGE CONTROL USING RESISTANCE (POTENTIOMETER)

When configured as shown in Figure 3-5, Preamp "A" with the built-in feedback and input resistors has a gain of one and the fixed gain of all BOP models is designed so that a d-c input signal of zero to ( $\pm$ )10 volts will control the BOP output through its full positive and negative range. This is accomplished by the external Remote Voltage Control potentiometer shown in Figure 3-5.

With no additional external wiring  $\pm$ current limiting is automatically set to 110% of the nominal BOP output current. Full user control of current limits is accomplished using the external configurations described in PAR. 3.3.5.

**NOTE:** During normal operation in Voltage mode, The front panel Voltage Mode/Voltage Limit indicator lights green, and the Current Mode/Current Limit indicator is off. If the output current exceeds the preadjusted value at any time, the Voltage Mode/Voltage Limit indicator will go off and the Current Mode/Current Limit indicator will light yellow. After the cause of overcurrent is eliminated, the indicators will return to their initial status.

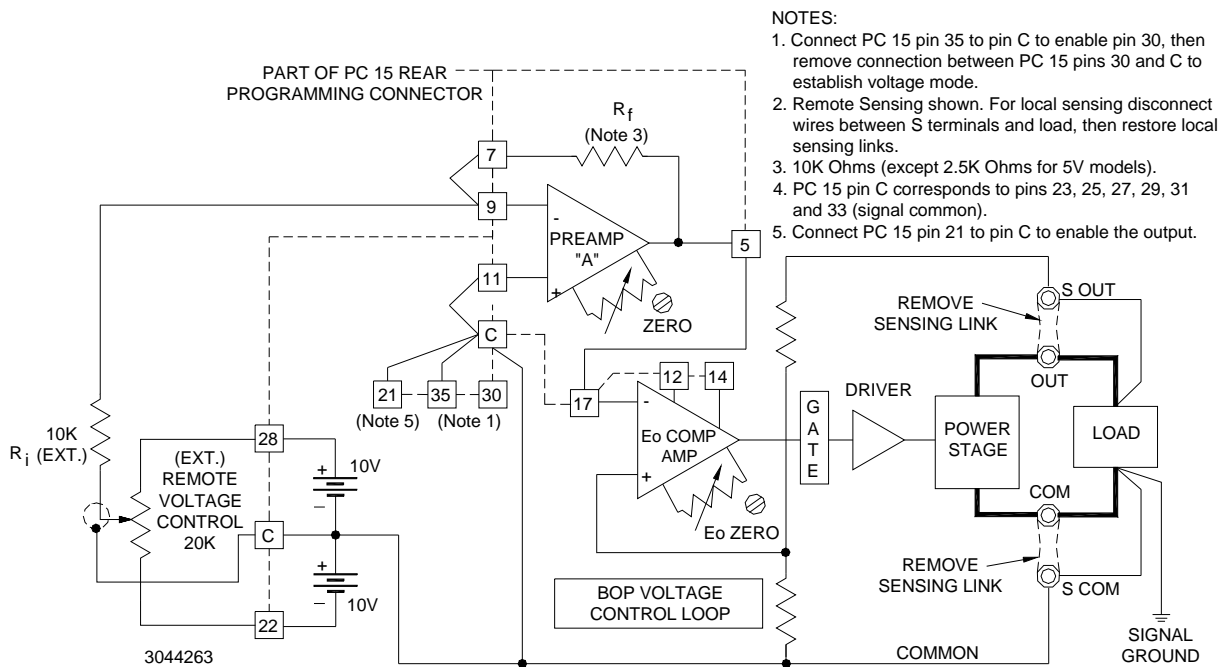

**NOTES:**

1. Connect PC 15 pin 35 to pin C to enable pin 30, then remove connection between PC 15 pins 30 and C to establish voltage mode.
2. Remote Sensing shown. For local sensing disconnect wires between S terminals and load, then restore local sensing links.
3. 10K Ohms (except 2.5K Ohms for 5V models).
4. PC 15 pin C corresponds to pins 23, 25, 27, 29, 31 and 33 (signal common).
5. Connect PC 15 pin 21 to pin C to enable the output.

**FIGURE 3-5. REMOTE POTENTIOMETER CONTROL OF D-C OUTPUT VOLTAGE**



### 3.3.2 REMOTE VOLTAGE CONTROL USING RESISTANCE (DECADE BOX)

Two-terminal resistance control of the d-c voltage (for example, by means of a Decade Box (make-before-break type) or any variable resistance) can be exercised as shown in Figure 3-6.

The external switch (S1), connected across the ( $\pm$ ) reference voltage, is used to pre-select either positive or negative output by setting it to the applicable reference voltage polarity.

PREAMP "A" functions here as an inverter. Its output can be expressed by the equation:

$$E_O (\text{PREAMP "A"}) = -E_{\text{ref}} (R_f/R_i). \text{ where}$$

$R_f$  = Decade Resistor, 0 - 10K Ohms (except 0 - 2.5K Ohms for 5V models)

$R_i$  = Ext. Input Resistor

The BOP output voltage will vary linearly with the change in decade resistance.

This programming system can be calibrated very accurately by setting the external Remote Voltage Control (Decade) to zero, and adjusting for zero output volts using the screwdriver-adjusted  $E_O$  ZERO control while monitoring the BOP output with a digital voltmeter. The maximum output voltage is calibrated by making all or part of  $R_i$  a rheostat and adjusting it with the Remote Voltage Control at maximum resistance, to the maximum BOP output voltage.

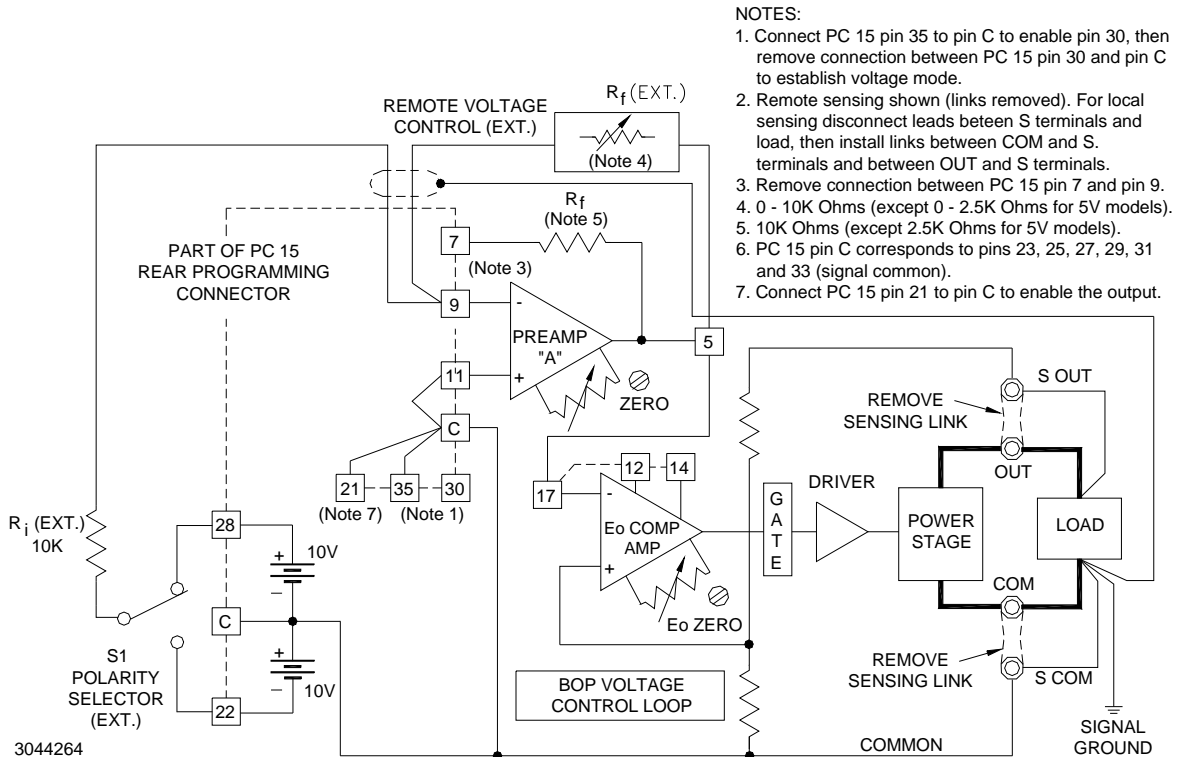

**FIGURE 3-6. REMOTE D-C OUTPUT VOLTAGE CONTROL USING TWO-TERMINAL RESISTANCE (DECADE)**

### 3.3.3 REMOTE VOLTAGE CONTROL USING D-C SIGNAL VOLTAGE

The BOP d-c output voltage can be controlled directly by a  $\pm 10V$  d-c signal, applied to the rear programming connector pin 9 referenced to common. An interesting example of how this can be implemented is the use of a Kepco SN Digital Programmer to convert digital input to the analog  $\pm 10V$  d-c signal. The digital input to the SN programmer can be provided by a computer, or manually by means of a keyboard. The analog output from the SN is from zero to  $\pm 10$  volts and constitutes the input programming voltage for the BOP.

The connections between the SN Programmer and the BOP are illustrated in Figure 3-7. This programming system provides a resolution of 12-bits with a linearity of  $(\pm)1/2$  LSB (0.0122%). The digital and the power supply grounds are isolated (optical isolation) to 1000 volts. Calibration of the system is performed with the provided controls on the SN Programmer.

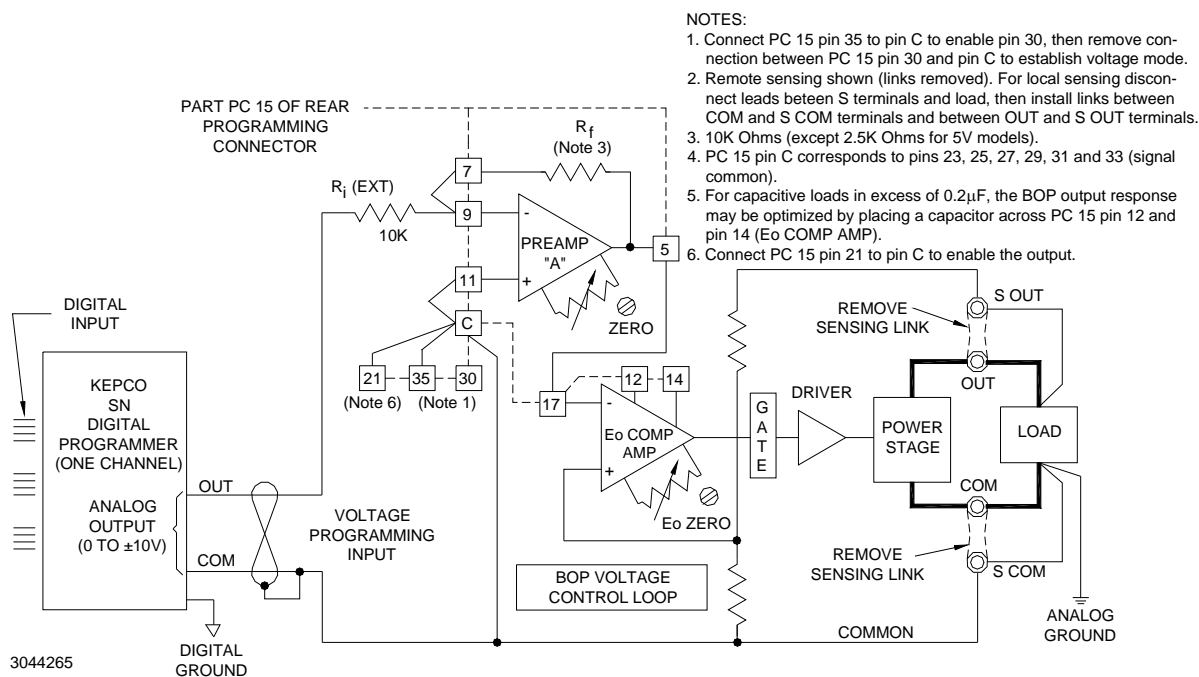
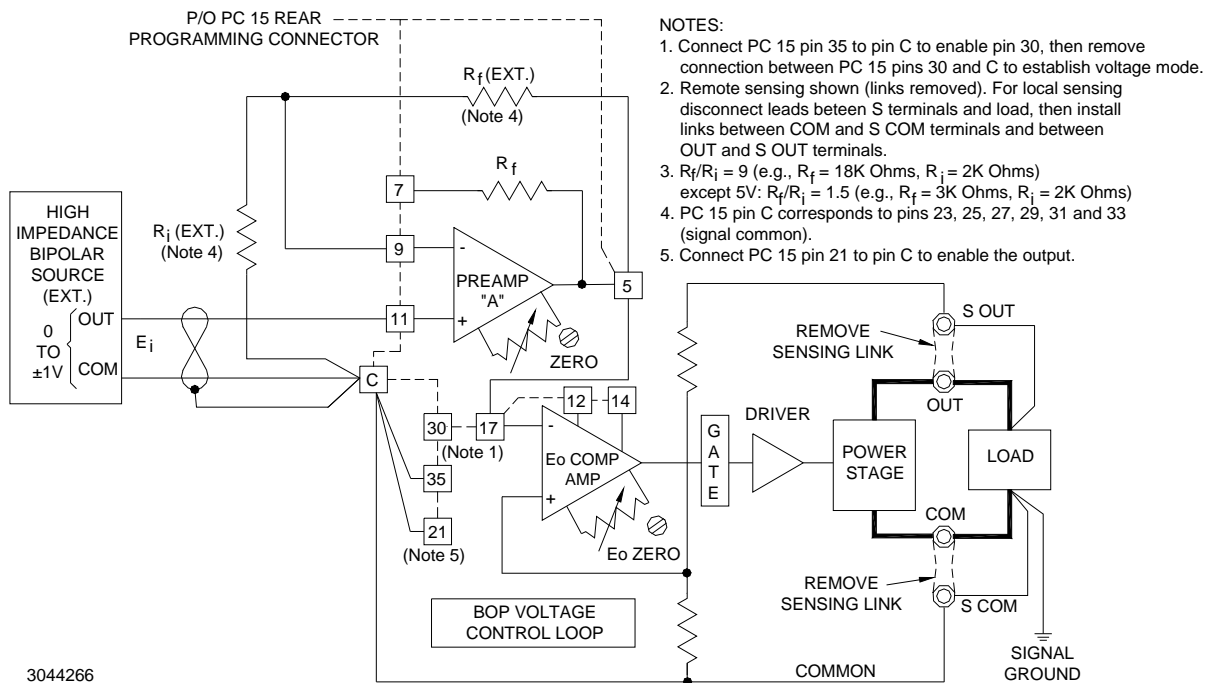

FIGURE 3-7. EXTERNAL DIGITAL CONTROL OF THE D-C OUTPUT VOLTAGE

Since all terminals of Preamp "A" are available at the Rear Programming Connector, d-c output voltage control can be exercised in many other ways. Preamp "A" can be treated as an uncommitted operational amplifier, with its applicable transfer functions. Its initial offsets can be zeroed with the provided control. The basic principle of d-c output voltage control of the BOP is that an Input control voltage of  $(\pm)10$  volts able to deliver 1mA applied to rear programming connector pin 9 (through an external 10k Ohm resistor), referenced to common, will produce the full d-c output voltage swing of the BOP. If the selected control signal does not have the required amplitude or if the required control current cannot be supplied, the Preamp "A" configuration can be altered to provide the proper interface for the application.

For example, if the BOP d-c output is to be controlled by means of a bipolar, 1 volt, high impedance source, it can be connected to the BOP as shown in Figure 3-8.



**FIGURE 3-8. D-C OUTPUT VOLTAGE CONTROL WITH NON-INVERTING CONFIGURATION AND HIGH IMPEDANCE ±1V SIGNAL SOURCE**

As seen in Figure 3-8, the original input feedback components of Preamp "A" have been bypassed and are replaced by external resistors (metal film or wire-wound type resistors may be used and connected directly to the Rear Programming Connector terminals as shown). Preamp "A" is used in the non-inverting configuration, so the output voltage will have the same polarity as the input programming signal. Its output voltage (the necessary BOP control voltage) as shown in the examples below is given by:

$$E_O (\text{PREAMP "A"}) = E_i \frac{R_f + R_i}{R_i}$$

all models except 5V:  $E_O (\text{PREAMP "A"}) = (\pm 1V) \frac{18K\text{Ohms} + 2K\text{Ohms}}{2K\text{Ohms}} = \pm 10V$

$$E_{O(\text{unit})} = (\pm 10V) (G) = \pm E_{O\text{nom}} (V)$$

where G = Closed loop Gain V/V (see Table 1-3)

5V models:  $E_O (\text{PREAMP "A"}) = (\pm 1V) \frac{3K\text{Ohms} + 2K\text{Ohms}}{2K\text{Ohms}} = \pm 2.5V$

$$E_{O(\text{unit})} = (\pm 2.5V) (2V/V) = \pm 5V$$

Consequently, as the bipolar input voltage ( $E_i$ ) is controlled from  $-1V$  through zero to  $+1V$ , the BOP output voltage will follow over its specified range. Calibration of the system can be performed at the programming source, or the Preamp "A" ZERO and  $E_O$  ZERO controls can be used for the zero adjustment, while the feedback resistor ( $R_f$ ) can be trimmed to calibrate full scale.

### 3.3.4 USING THE BOP AS A VOLTAGE AMPLIFIER

If, instead of the d-c control signal (see PAR. 3.3.3), an a-c signal voltage is applied to the Voltage Programming Input terminals, the BOP functions as a bipolar amplifier. As an amplifier, the BOP voltage gain is set on each BOP model so that (as with the d-c control signal) a bipolar a-c input signal with an amplitude of 0V to 20V (peak-to-peak) will drive the BOP output through its specified ( $\pm$ ) output voltage range. All other dynamic specifications are given in Table 1-4.

The BOP can be used to amplify, sum or scale a variety of waveshapes, some of which are illustrated in Figure 3-9. All input signals are shown 180° out of phase with their corresponding output waveshapes. The latter can be readily produced in phase (i.e. with the output wave taking the same direction as the input signal) by addressing the non-inverting input of Preamp "A."

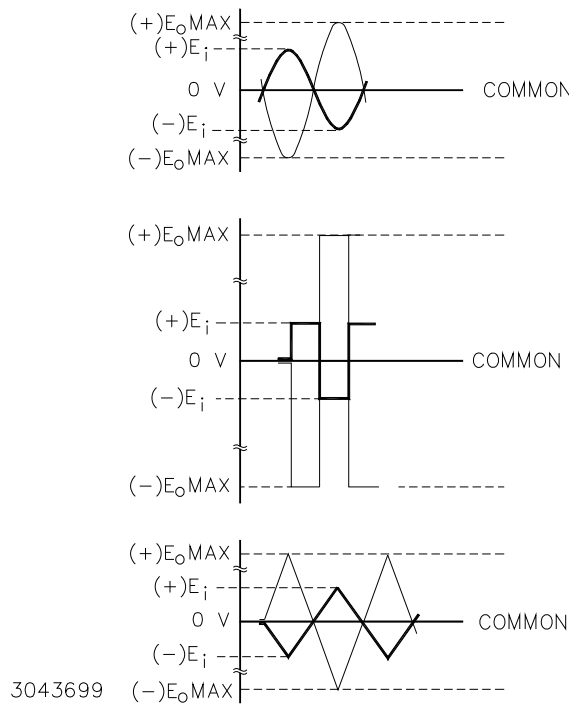

**FIGURE 3-9. GRAPHS OF POSSIBLE INPUT/OUTPUT WAVESHAPES**

The basic programming circuit used to produce the waveforms shown in Figure 3-9 is shown in Figure 3-10. Since all input signals of Figure 3-9 are shown with a  $\pm 10$  volts amplitude, the basic programming circuit in Figure 3-10 must be modified if the external signal source cannot produce 10 volts and if the full BOP output voltage swing is required.

If the external programming source does not have sufficient amplitude to drive the BOP over its full output range, the gain of Preamp "A" must be changed from the built-in value to suit the application. To calculate the required components for the new gain requirement, the output equation for Preamp "A" in the inverting configuration is used:

$$E_O (\text{PREAMP "A"}) = -E_i (R_f/R_i)$$

where  $E_O$  (Preamp "A") =  $\pm 10$ V ( $\pm 2.5$ V for 5V models), and the values of  $R_f$  and  $R_i$  depend on the available amplitude of the programming source. If, for example, a  $\pm 1$  volt source able to deliver 0.1mA is available, the ratio  $R_f/R_i$  must be 10 (2.5 for 5V models), and the two resistor

values can be  $R_i = 10K$  and  $R_f = 100K$  ( $R_i = 10K$  and  $R_f = 25K$  for 5V models) respectively.  $R_i = 10K$  can be retained, and only  $R_f$  must be replaced with a 100K (25K for 5V models) metal film, 1/2 watt resistor. The necessary connections are illustrated in Figure 3-11. Gain control can be exercised by making  $R_f$  a rheostat instead of a fixed resistor.

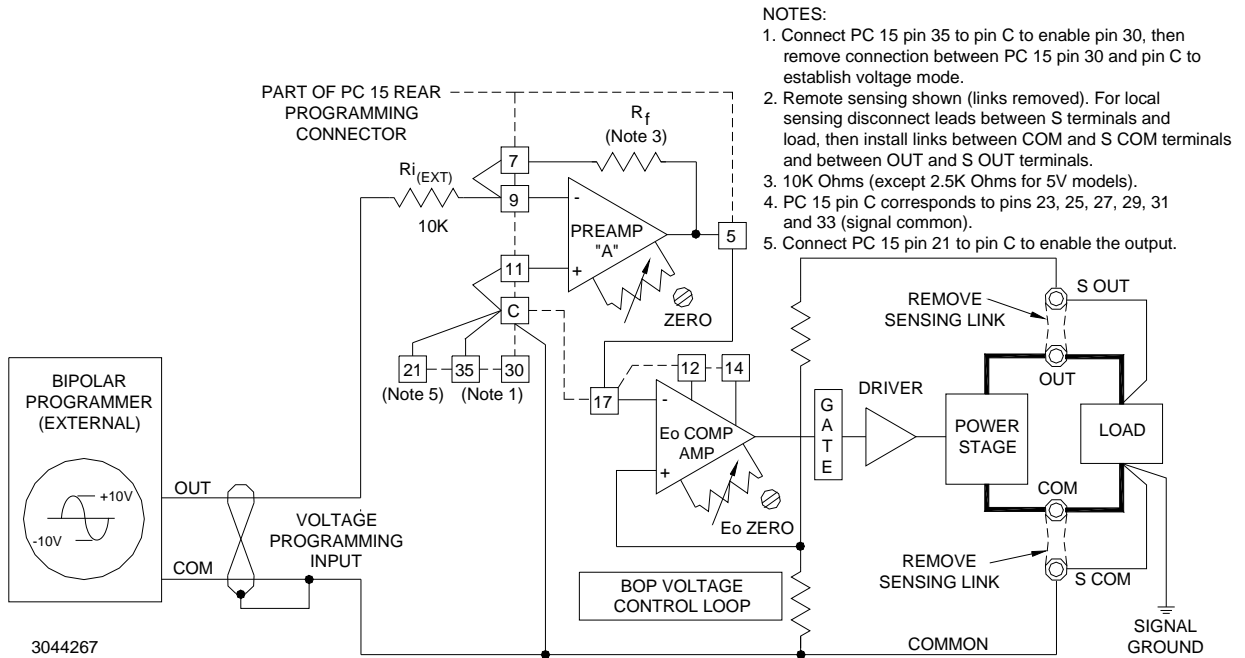

**FIGURE 3-10. BASIC PROGRAMMING CIRCUIT FOR USE OF BOP AS BIPOLAR AMPLIFIER (VOLTAGE MODE)**

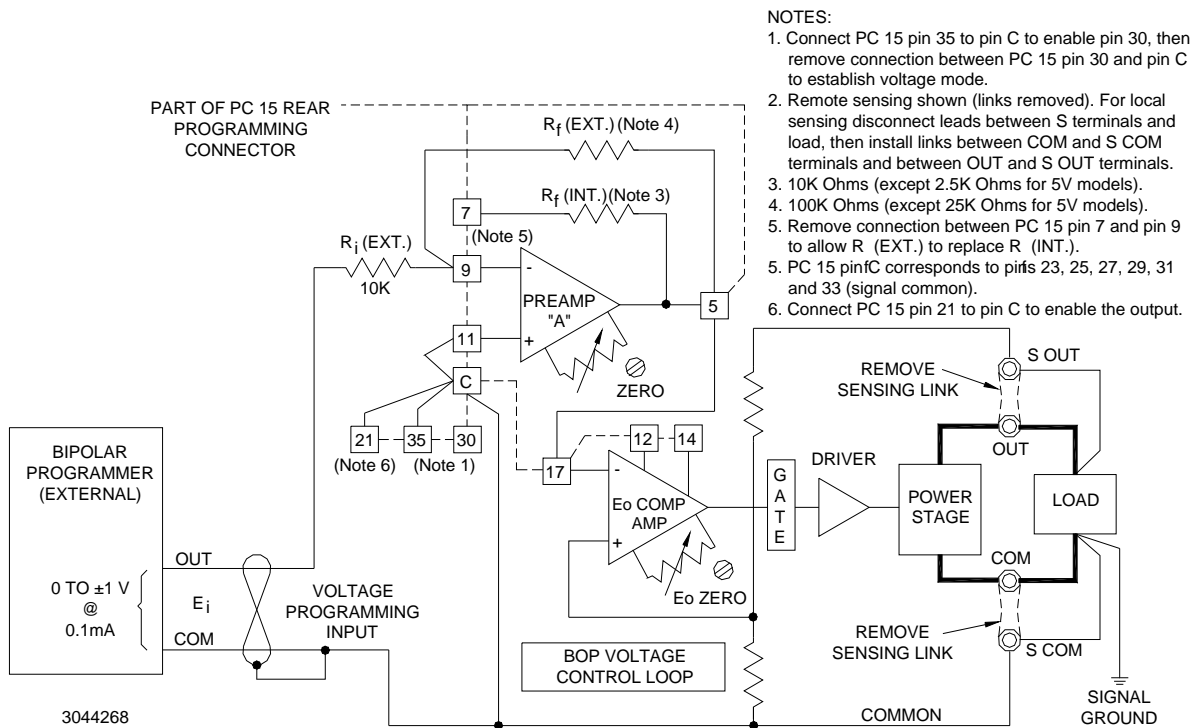

**FIGURE 3-11. PROGRAMMING CIRCUIT FOR DRIVING OUTPUT VOLTAGE WITH  $\pm 1V$  INPUT PROGRAMMING VOLTAGE**

### 3.3.5 REMOTE CONTROL OF CURRENT LIMITING

For remote control of current limiting, the  $\pm I_O$  Limit Amplifiers (EXT) are disconnected from the 15V Bias source by removing connections between pin 1 and pin 34 and between pin 34 and pin 8 at the Rear Programming Connector (see Figure 3-12). An external 0 to +10V control signal is applied to pins 8 and 34, with reference to common. This control signal programs both the negative and positive current limit simultaneously and symmetrically over the BOP output current range.

If individual control of the  $\pm$  current limits is desired, the jumper between pin 8 and pin 34 at the Rear Programming Connector must be removed and separate control sources must be connected: 0 to +10 volts to pin 8 for the  $+ I_O$  limit, and 0 to +10 volts to pin 34 for the  $- I_O$  limit, both with reference to common (see Figure 3-13).

**NOTE:** If a control voltage is not applied to pins 8 and 34 of the Rear Programming Connector, the  $\pm I_O$  LIMIT value is automatically set to 110% of the rated nominal current of the BOP. This is a backup of the external programming of current limits described above.

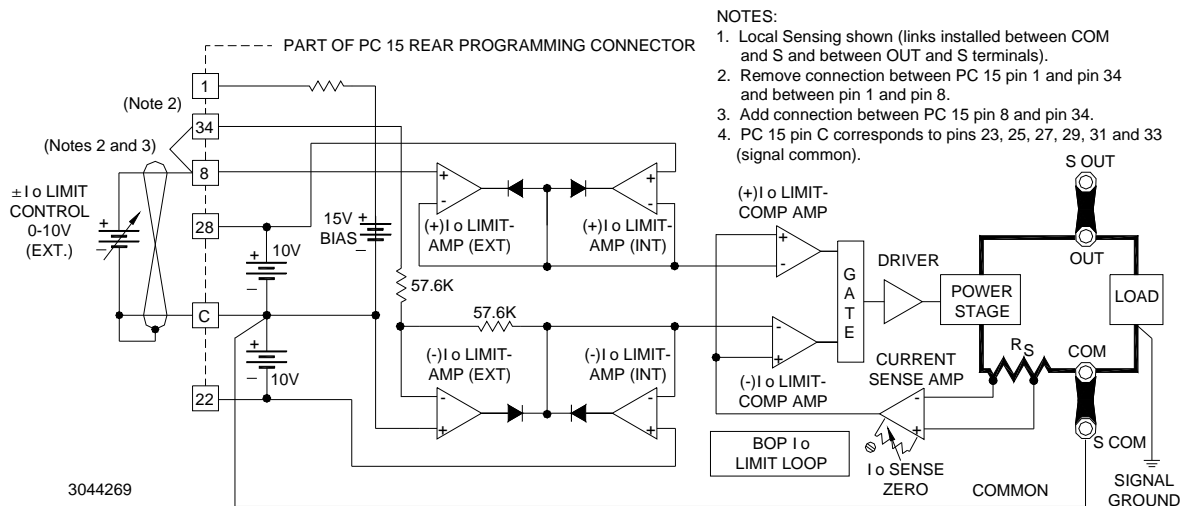

- NOTES:
1. Local Sensing shown (links installed between COM and S and between OUT and S terminals).
  2. Remove connection between PC 15 pin 1 and pin 34 and between pin 1 and pin 8.
  3. Add connection between PC 15 pin 8 and pin 34.
  4. PC 15 pin C corresponds to pins 23, 25, 27, 29, 31 and 33 (signal common).

**FIGURE 3-12. SYMMETRICAL REMOTE CONTROL OF THE CURRENT LIMITS**

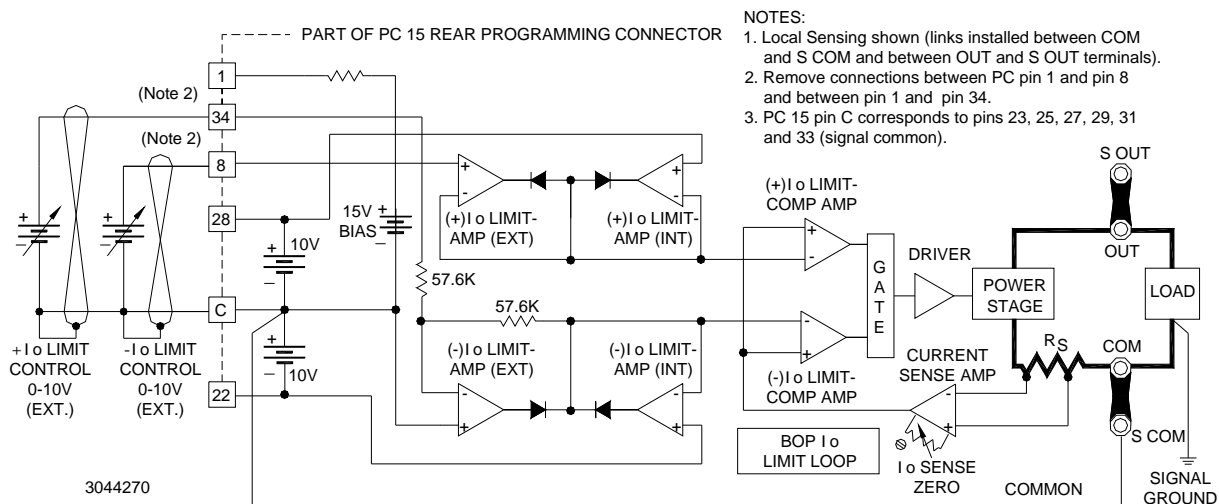

- NOTES:
1. Local Sensing shown (links installed between COM and S COM and between OUT and S OUT terminals).
  2. Remove connections between PC pin 1 and pin 8 and between pin 1 and pin 34.
  3. PC 15 pin C corresponds to pins 23, 25, 27, 29, 31 and 33 (signal common).

**FIGURE 3-13. INDEPENDENT REMOTE CONTROL OF  $+ I_O$  AND  $- I_O$  LIMITS**

### 3.4 REMOTE CONTROL OF CURRENT CONTROL CHANNEL

Since the input signal requirements for the control of the BOP output current are the same as for programming the output voltage, and since the control circuitry of the current channel is almost identical to that of the voltage channel, all programming circuit descriptions for programming the output voltage of the BOP can be applied to current programming. The current programming circuits are illustrated in the following diagrams. Any comments specifically applicable to current channel programming are noted on the diagrams.

NOTE: Adjust the zero output current point by means of the built-in ZERO control of Preamp "B" or that of the  $I_o$  Comp. Amp.

#### 3.4.1 REMOTE CURRENT CONTROL USING RESISTANCE (POTENTIOMETER)

Similar to remote voltage control mode described in PAR. 3.3.1, the BOP output current can be controlled over the full output range by means of an external resistance as shown in Figure 3-14. The control potential (zero to  $(\pm)10V$ ) is applied via Preamp "B," operating with unity gain, to the  $I_o$  Comp. Amp which drives the Power Stage with a fixed gain as listed in Table 1-3. A d-c control signal from zero to  $(\pm)10V$  will, therefore, control the BOP output current through its specified range.

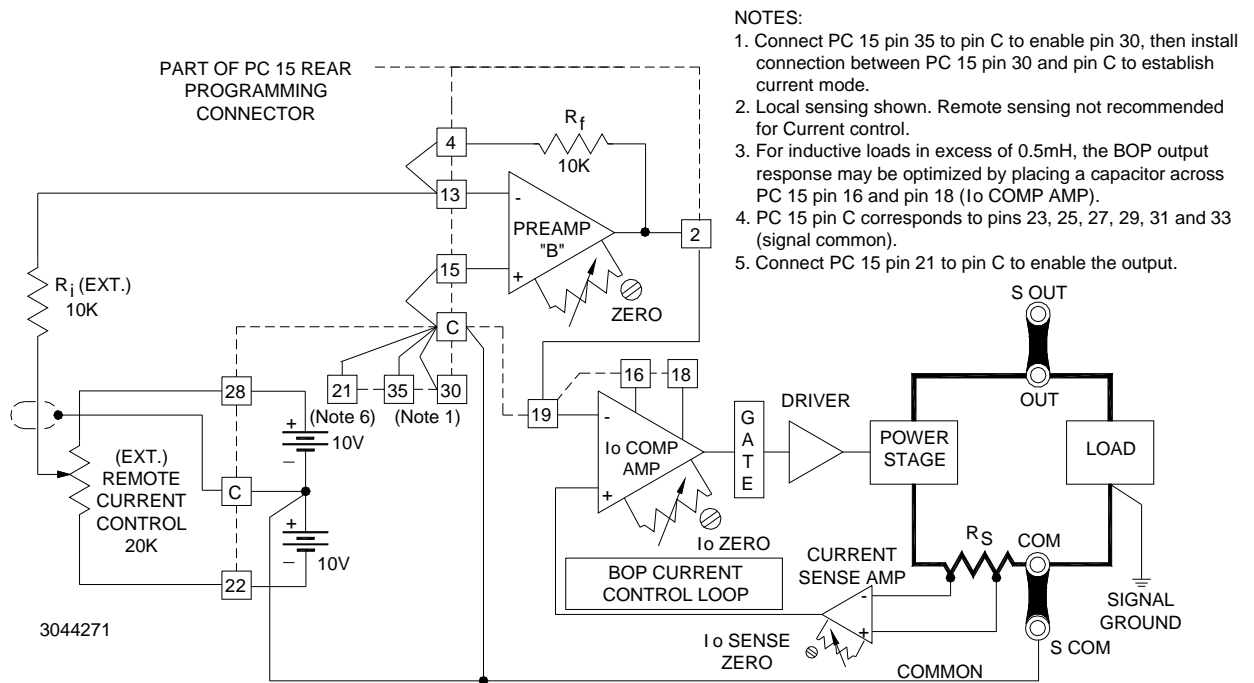

- NOTES:
1. Connect PC 15 pin 35 to pin C to enable pin 30, then install connection between PC 15 pin 30 and pin C to establish current mode.
  2. Local sensing shown. Remote sensing not recommended for Current control.
  3. For inductive loads in excess of 0.5mH, the BOP output response may be optimized by placing a capacitor across PC 15 pin 16 and pin 18 ( $I_o$  COMP AMP).
  4. PC 15 pin C corresponds to pins 23, 25, 27, 29, 31 and 33 (signal common).
  5. Connect PC 15 pin 21 to pin C to enable the output.

FIGURE 3-14. REMOTE POTENTIOMETER CONTROL OF THE BOP OUTPUT CURRENT

### 3.4.2 REMOTE CURRENT CONTROL USING RESISTANCE (DECADE BOX)

See Figure 3-15 for remote current control using a two-terminal resistance (decade box)

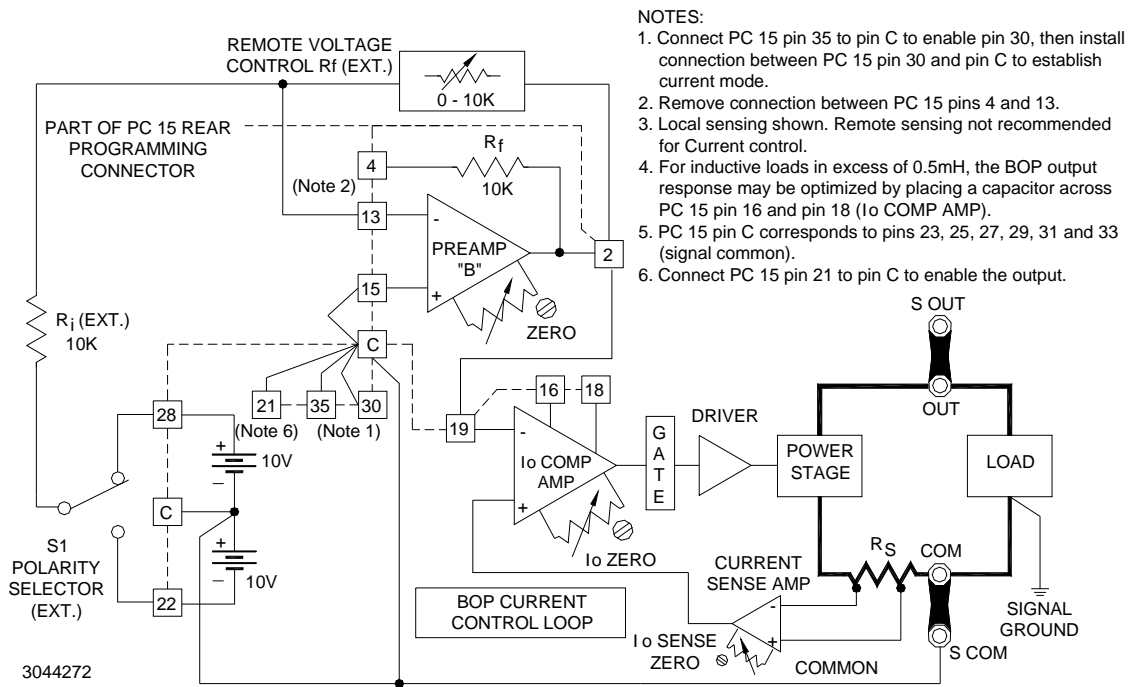

FIGURE 3-15. REMOTE D-C OUTPUT CURRENT CONTROL USING TWO-TERMINAL RESISTANCE (DECADE)

### 3.4.3 REMOTE CURRENT CONTROL USING D-C SIGNAL VOLTAGE

See Figure 3-16 for remote current control using a d-c signal voltage.

See Figure 3-17 for remote current control using a high impedance  $\pm 1V$  voltage. Pre-amplifier "B" is used in the non-inverting configuration, so the output current will have the same polarity as the input programming signal.



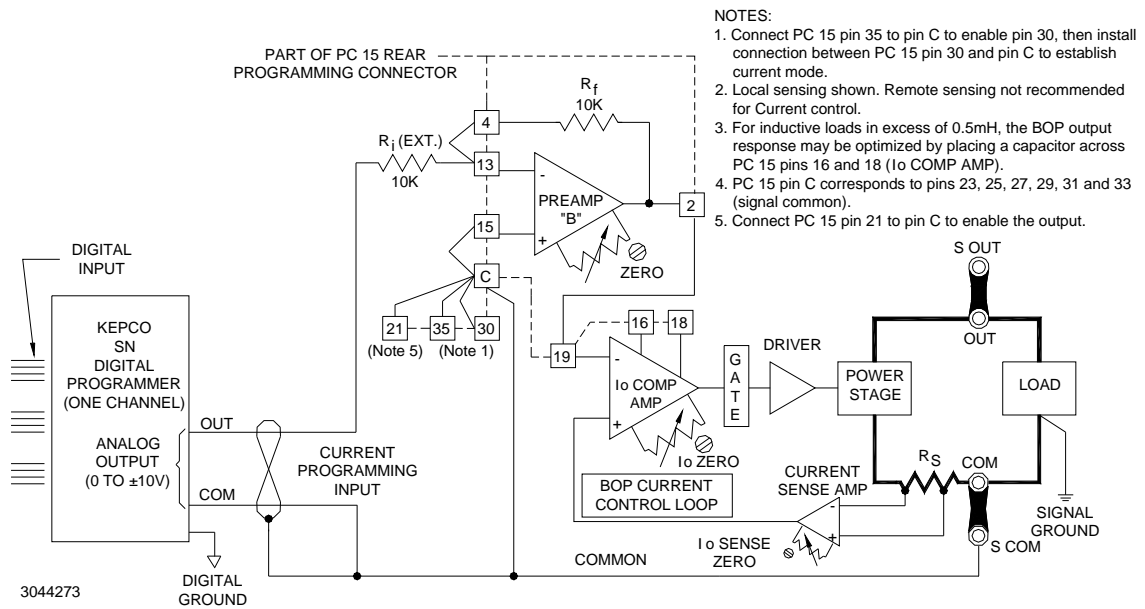

FIGURE 3-16. DIGITAL CONTROL OF OUTPUT CURRENT

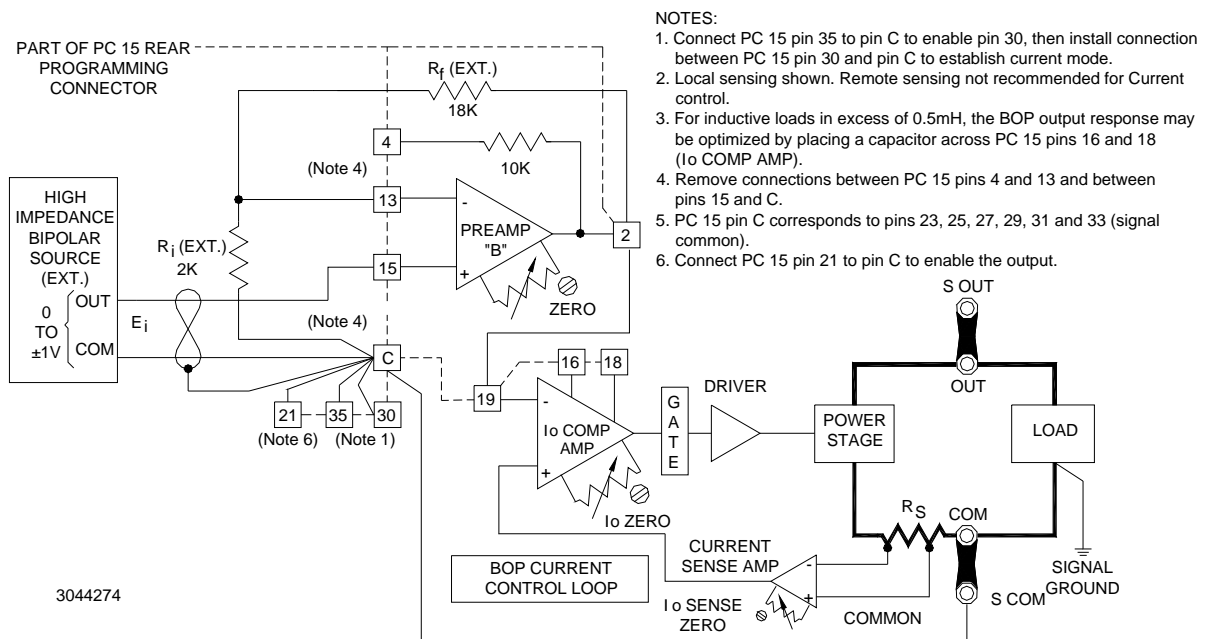

FIGURE 3-17. BOP OUTPUT CURRENT CONTROL WITH NON-INVERTING CONFIGURATION AND HIGH IMPEDANCE (±)1 VOLT SIGNAL SOURCE

### 3.4.4 USING THE BOP AS A CURRENT AMPLIFIER

See Figure 3-18 to configure the BOP as a current-stabilized bipolar amplifier.

See Figure 3-19 to drive output current using a bipolar signal voltage less than  $\pm 10V$ .

See Figure 3-20 to drive output current using a high impedance source.

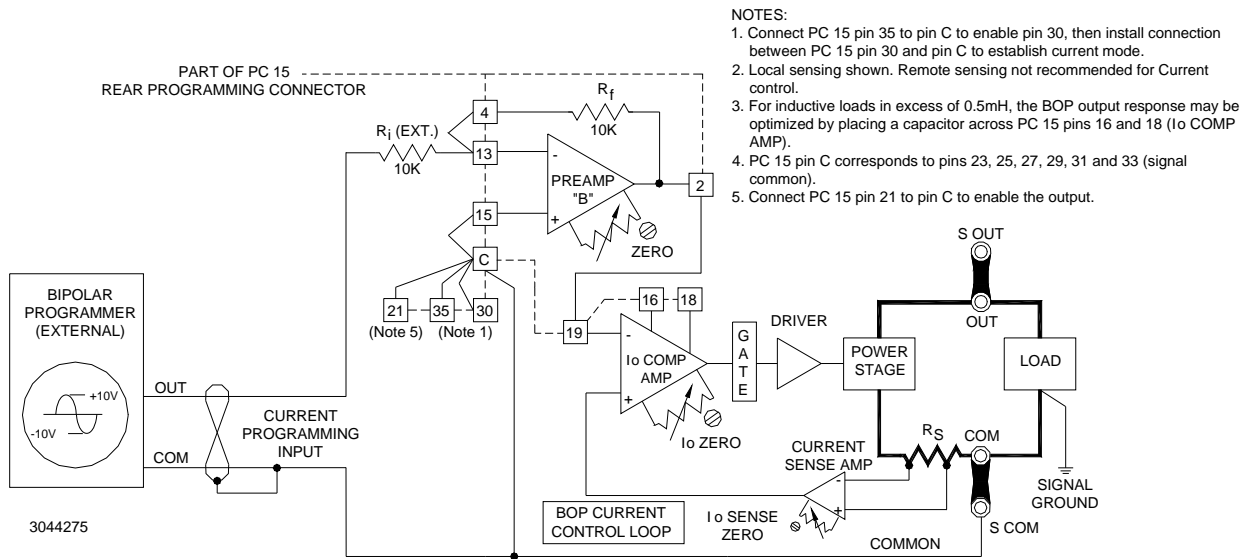

**FIGURE 3-18. BASIC PROGRAMMING CIRCUIT FOR BOP AS BIPOLAR CURRENT-STABILIZED AMPLIFIER**

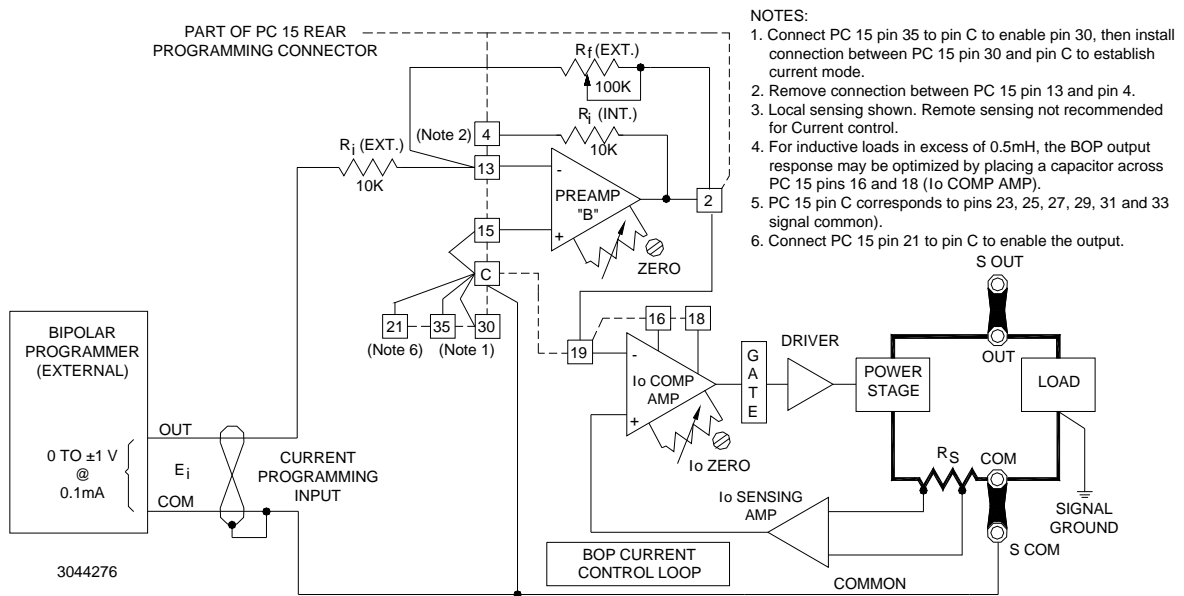

**FIGURE 3-19. PROGRAMMING CIRCUIT FOR DRIVING OUTPUT CURRENT WITH ±1V INPUT PROGRAMMING VOLTAGE**

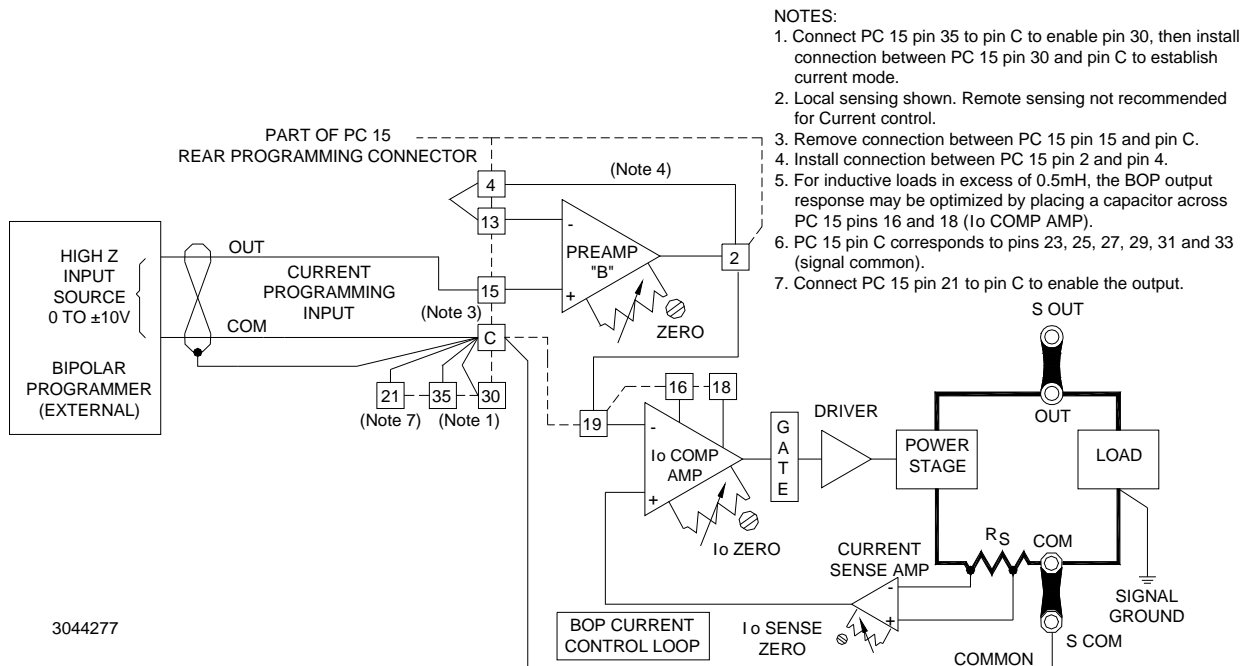

**FIGURE 3-20. PROGRAMMING CIRCUIT FOR DRIVING OUTPUT CURRENT WITH A HIGH IMPEDANCE SOURCE**

### 3.4.5 REMOTE CONTROL OF VOLTAGE LIMITING

The  $E_O$  Limit circuit can be configured to use a single external 0 to 10V d-c programming source to symmetrically control  $\pm$  Voltage Limits as shown in Figure 3-21. The circuit functions in a manner similar to the  $I_O$  Limit circuit (refer to Paragraph 3.3.5), except that the voltage limit feedback is derived by means of a voltage divider across the BOP output.

The + and - voltage limit can be controlled independently by individual 0 to 10V d-c sources, as illustrated in Figure 3-22.

**NOTE:** If a control voltage is not applied to pins 6 and 32 of the Rear Programming Connector, the  $\pm E_O$  LIMIT value is automatically set to 110% of the rated nominal voltage of the BOP. This is a backup of the external programming of voltage limits described above.

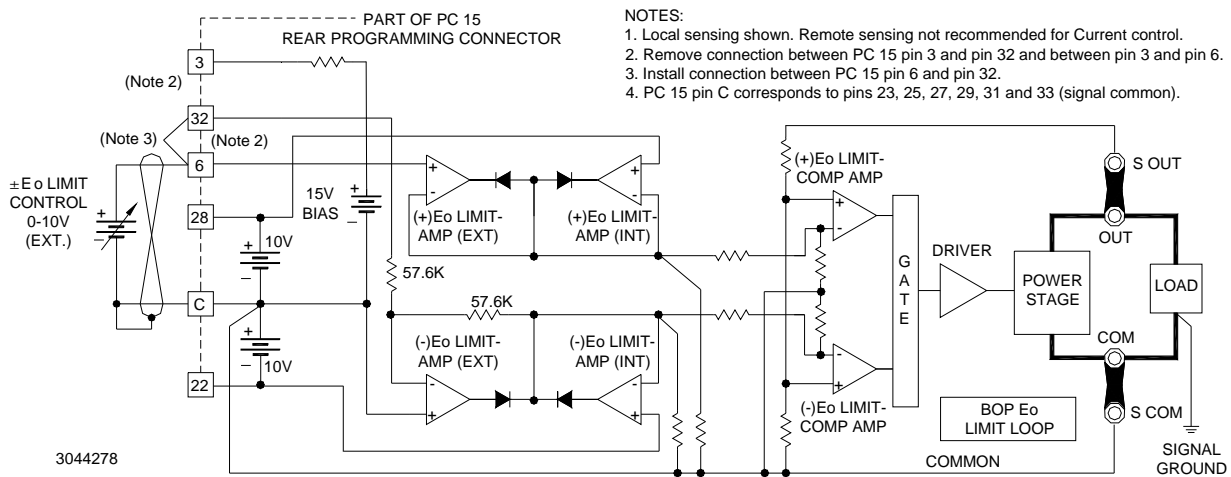

**FIGURE 3-21. SYMMETRICAL REMOTE CONTROL OF VOLTAGE LIMIT**

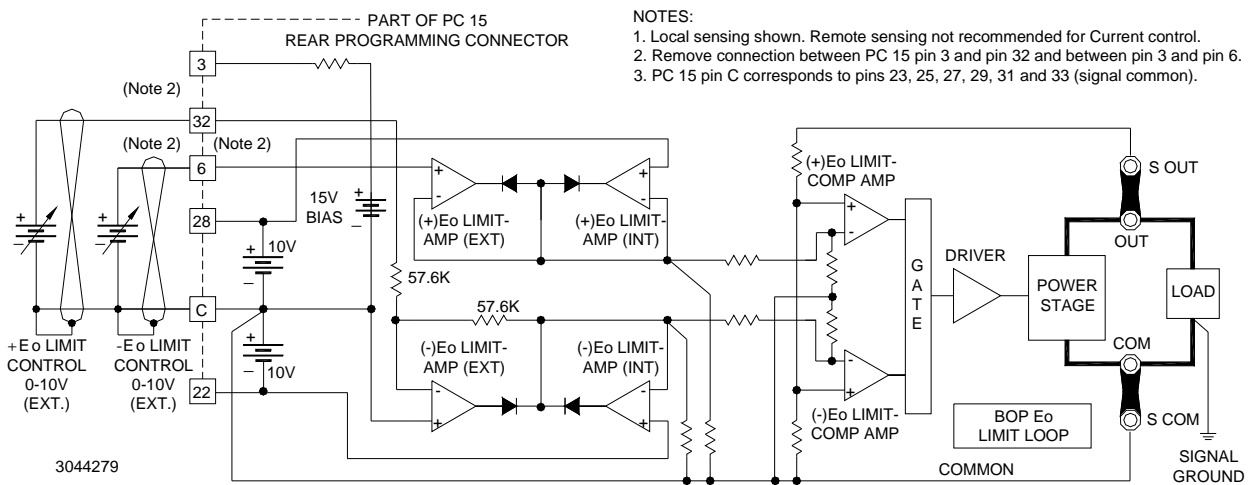

**FIGURE 3-22. INDEPENDENT REMOTE CONTROL OF +E<sub>o</sub> AND -E<sub>o</sub> VOLTAGE LIMIT**

### 3.5 SERIES AND PARALLEL CONNECTION OF BOP CHANNELS

Voltage sources, such as batteries, cells or stabilized d-c power supplies can be readily series-connected, but normally they can not be paralleled. Even small differences in their terminal potential would cause large, damaging, circulating currents. By complementary reasoning, current sources can easily be paralleled, but not series-connected.

There are two basic methods which are commonly used for the series or parallel connection of stabilized d-c power supplies. The first method is the "Automatic" series or parallel connection by which the power supply outputs are simply connected together, in series or parallel, as required. The "Automatic" method presents no problems as long as it is confined to series connection with voltage sources, or to parallel connection with current sources. The proper settings for automatic series and parallel connection are as follows:

- Automatic series connection: All BOP channels configured for voltage control. Set current limit of one channel lower than current limit for the other.
- Automatic parallel connection: All BOP channels configured for current control. Set voltage limit of one channel lower than voltage limit for the other.

The second method for series or parallel connection of BOP channels is the Master/Slave configuration, by which a designated Master channel controls the output of the Slave channel. This control method permits control of the common output by a single channel - the Master. Since this method presents the least problems for either series or parallel connections and since it is readily implemented with BOP power supplies, it is the recommended method for this kind of operation and is described below.

#### 3.5.1 SERIES CONNECTION, MASTER/SLAVE OPERATION

Two BOP channels can be connected in series to increase the unit's output voltage. The Slave channel is set to always be in voltage mode, adding to the output voltage of the Master channel by repeating the Master's voltage, while the Master can operate in either voltage mode or current mode as needed. Figure 3-23 shows a Master/Slave connection of the two BOP channels of a BOP 2X-D Dual Channel unit.

Proceed as follows:

1. Connect the BOP channels as shown in Figure 3-23.
  - a. Load-wire size should be rated to at least the maximum load current and load-wire pairs should be twisted or tied together to keep the inductance and EMI as low as possible. For remote sensing, use #22 AWG twisted pair wires.
  - b. Use shielded cable for connecting the coupling resistor ( $R_T$ ). Connect shield to chassis-ground. Either the positive or the negative output side of the system can be grounded.
  - c. The coupling resistor ( $R_T$ ) should be either a wirewound or a metal film component with a low temperature coefficient. It is calculated by:  
$$R_T \text{ (KOhms)} = (E_{OM} \text{ (MAX) Volts})/1\text{mA}$$
This value of  $R_T$  will be able to drive the Slave channel to its ( $\pm$ ) maximum output voltage as the Master channel is controlled through its range.

d. The BOP Circuit Breaker Control Circuit, as described in PAR. 3.5.2, should be used to interconnect both BOP channels in such a way that if one of them should fail, the other one is automatically shut down also.

2. Turn BOP channels on and begin operation. The system as shown in Figure 3-23 operates in Voltage Mode, since the Master Channel is set to voltage mode (no connection between PC 15 pins 30 and C (common)). For operation in Current Mode, set the Master to Current mode by installing a connection between PC 15 pins 30 and C (common).

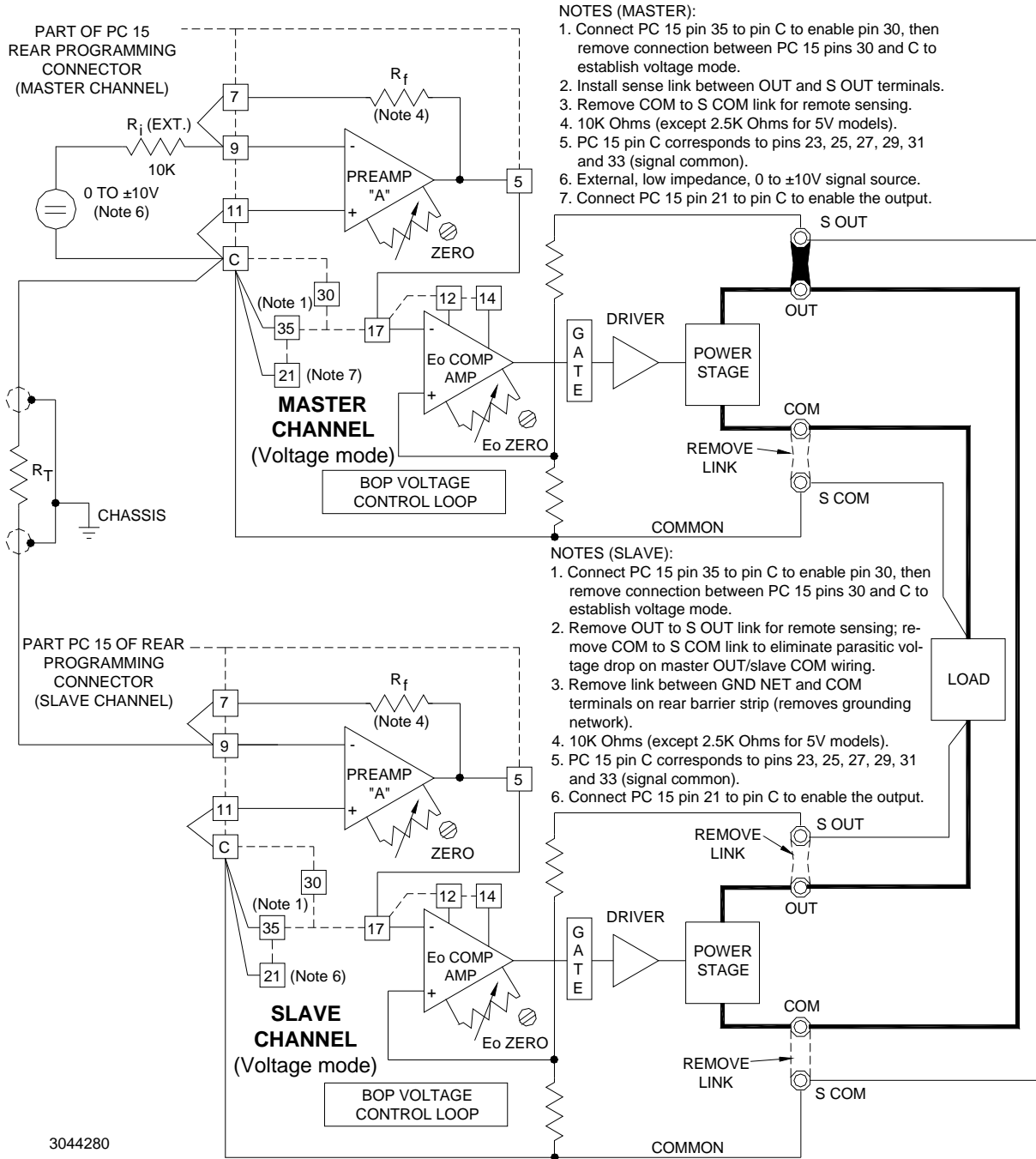

**FIGURE 3-23. SERIES CONNECTION, MASTER/SLAVE, VOLTAGE CONTROL OF TWO BOP 2X-D CHANNELS WITH REMOTE ERROR SENSING AT THE COMMON LOAD**

### 3.5.2 CIRCUIT BREAKER CONTROL CIRCUIT

Each BOP channel is protected by the dual-coil circuit breaker/ON-OFF switch (CB101) as shown in Figure 3-24. The current sensing coil of CB101 is connected in series with the primary winding of T201, thus detecting overcurrent reflected into the primary circuit and subsequently tripping the circuit breaker. The voltage sensing coil of CB101 is connected in series with an SCR (CR4) across the driver collector supply. If the SCR is triggered on, the voltage sensing coil is energized and trips the circuit breaker. The SCR (CR4) can be triggered in several ways:

- On a-c line power loss or interruption, Q1 will lose its turn-on bias first, due to the small time-constant provided in its base circuit (not shown in the simplified block diagram). As a result, Q2 is turned on, energizing the diode in the optical isolator (LC1) and providing a turn-on signal for the SCR (CR4).
- In the event of an excessive heat rise on the power stage assembly, the thermal switch (S401) will close, energizing the diode in the optical isolator (LC1) and providing thus the turn-on signal for the SCR (CR4).
- An input signal applied across pins 49 (+) and 47 (–) of the PC 15 Rear Programming Connector energizes the diode in the second optical isolator (LC-2) which, in turn, energizes the diode in the first optical isolator (LC1), thus providing for SCR turn-on.

NOTE: Upon turn-off, an isolated output signal is available at PC 15 Rear Programming Connector pins 26 (+) and 36 (–). This output signal can be used to turn off other equipment when the BOP is turned off. As an example, applying it across pins 49 and 47 of the Rear Programming Connector of the other BOP channel allows the master of a parallel or series configuration to turn off the slave when the master is turned off.

- A manual, non-isolated turn-off is provided which, when implemented with an external switch contact as shown in Figure 3-24, will energize the diode in the first optocoupler (LC1), thus providing the SCR turn-on.
- If it is not desired to trip the circuit breaker (CB101) upon a-c line power loss, it can be prevented by a connection or an external switch across pins 24 and 25 on the PC 15 Rear Programming Connector. In this manner, Q1 is inhibited from providing a turn-on signal for Q2, thus avoiding triggering the SCR and tripping the circuit breaker.

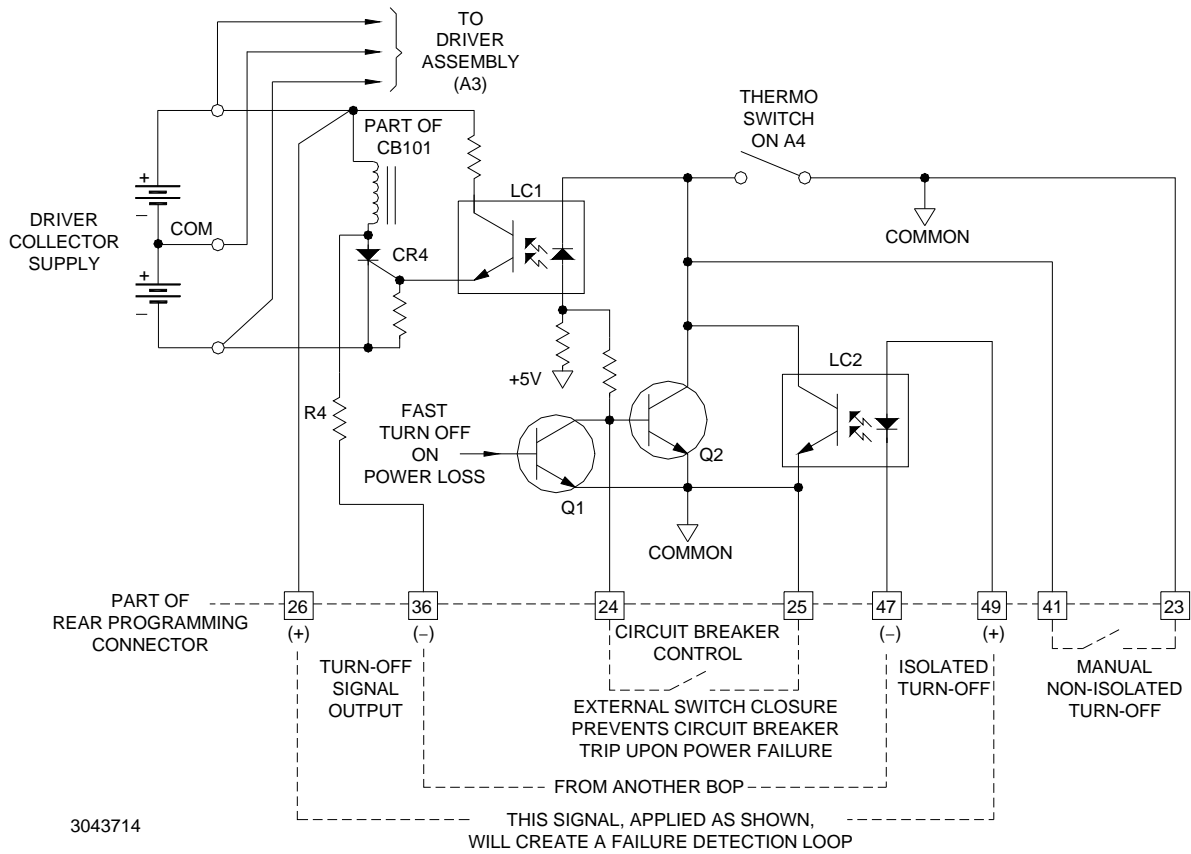

**FIGURE 3-24. CIRCUIT BREAKER CONTROL CIRCUIT, SIMPLIFIED DIAGRAM.**



### 3.5.3 PARALLEL CONNECTION, MASTER/SLAVE OPERATION

Both BOP channels of the BOP 2X-D Dual Channel unit can be connected in parallel to increase output current. The slave channel is set to always be in current mode, adding to the output current of the master by repeating the master's current, while the master can operate in either voltage mode or current mode as needed.

Figure 3-25 shows a simple parallel master/slave connection of no more than two BOP power supplies. Proceed as follows:

1. Connect the BOP supplies as shown in Figure 3-25.
  - a. Make the changes to the PC 15 Rear Programming Connector for Master and Slave channels as directed in the set-up diagram, Figure 3-25.
  - b. Load-wire size should be rated for at least the maximum load current and load-wire pairs should be twisted or tied together to keep the inductance and EMI as low as possible. Use shielded cable for the drive signal connection between the BOP channels. Connect the shield to common ground. For remote sensing, use #22 AWG twisted pair wires.
  - c. The BOP Circuit-Breaker Control Circuit, as described in PAR. 3.5.2 should be used to interconnect both BOP channels in such a way, that if one of them should fail, the other one is automatically shut down also.
2. Following the set-up procedure as described above, turn both BOP channels on and commence operation. The system as shown in the set-up diagram, Figure 3-25, operates in Voltage Mode, since the Master Channel is set to voltage mode (no connection between PC 15 pins 30 and C (common)). For operation in Current Mode, set the Master to Current mode by installing a connection between PC 15 pins 30 and C (common).

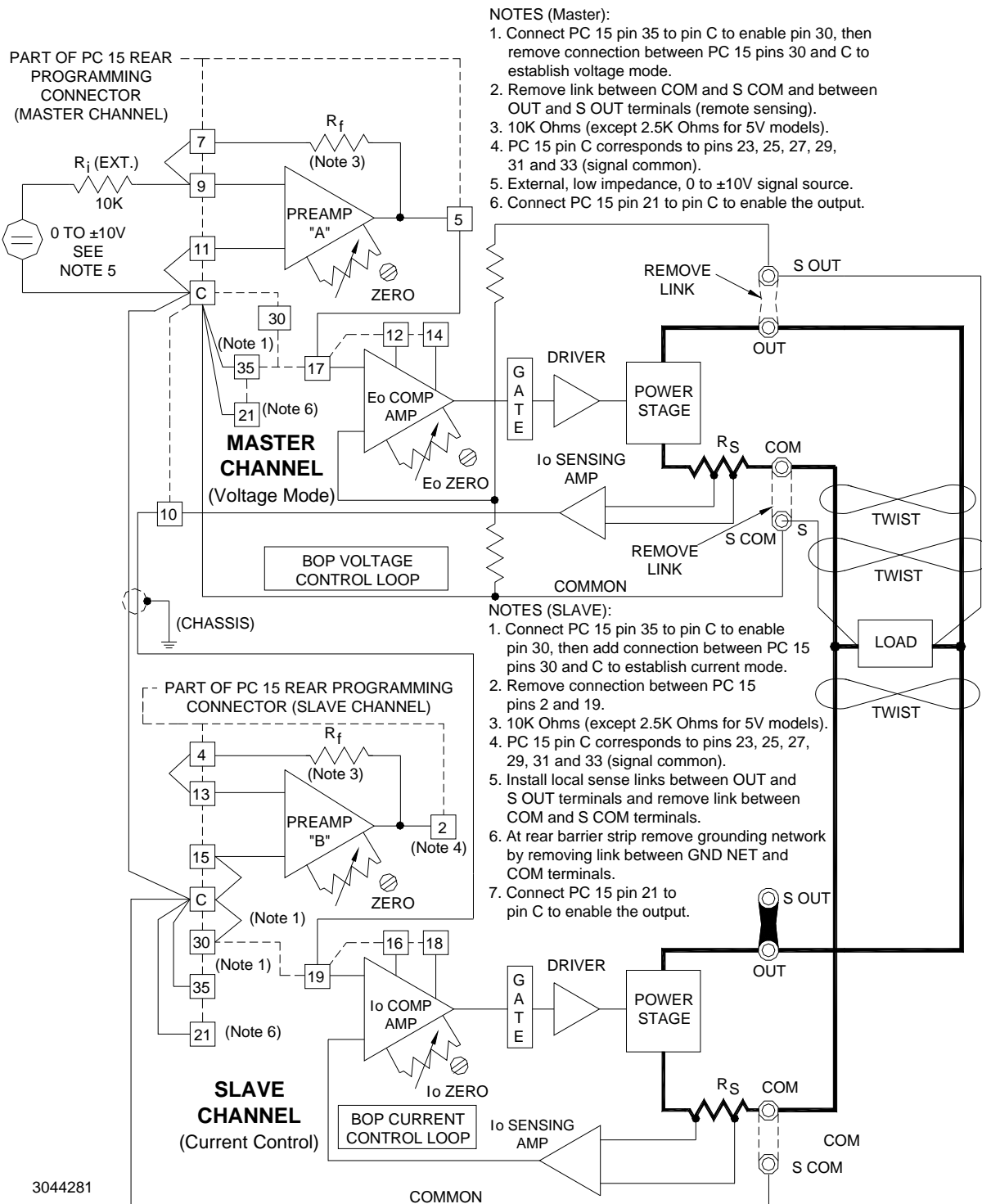

**NOTES (Master):**

1. Connect PC 15 pin 35 to pin C to enable pin 30, then remove connection between PC 15 pins 30 and C to establish voltage mode.
2. Remove link between COM and S COM and between OUT and S OUT terminals (remote sensing).
3. 10K Ohms (except 2.5K Ohms for 5V models).
4. PC 15 pin C corresponds to pins 23, 25, 27, 29, 31 and 33 (signal common).
5. External, low impedance, 0 to  $\pm 10V$  signal source.
6. Connect PC 15 pin 21 to pin C to enable the output.

**NOTES (SLAVE):**

1. Connect PC 15 pin 35 to pin C to enable pin 30, then add connection between PC 15 pins 30 and C to establish current mode.
2. Remove connection between PC 15 pins 2 and 19.
3. 10K Ohms (except 2.5K Ohms for 5V models).
4. PC 15 pin C corresponds to pins 23, 25, 27, 29, 31 and 33 (signal common).
5. Install local sense links between OUT and S OUT terminals and remove link between COM and S COM terminals.
6. At rear barrier strip remove grounding network by removing link between GND NET and COM terminals.
7. Connect PC 15 pin 21 to pin C to enable the output.

**FIGURE 3-25. PARALLEL CONNECTION (MASTER/SLAVE) OF TWO BOP 2X-D CHANNELS WITH REMOTE ERROR SENSING AT THE COMMON LOAD**

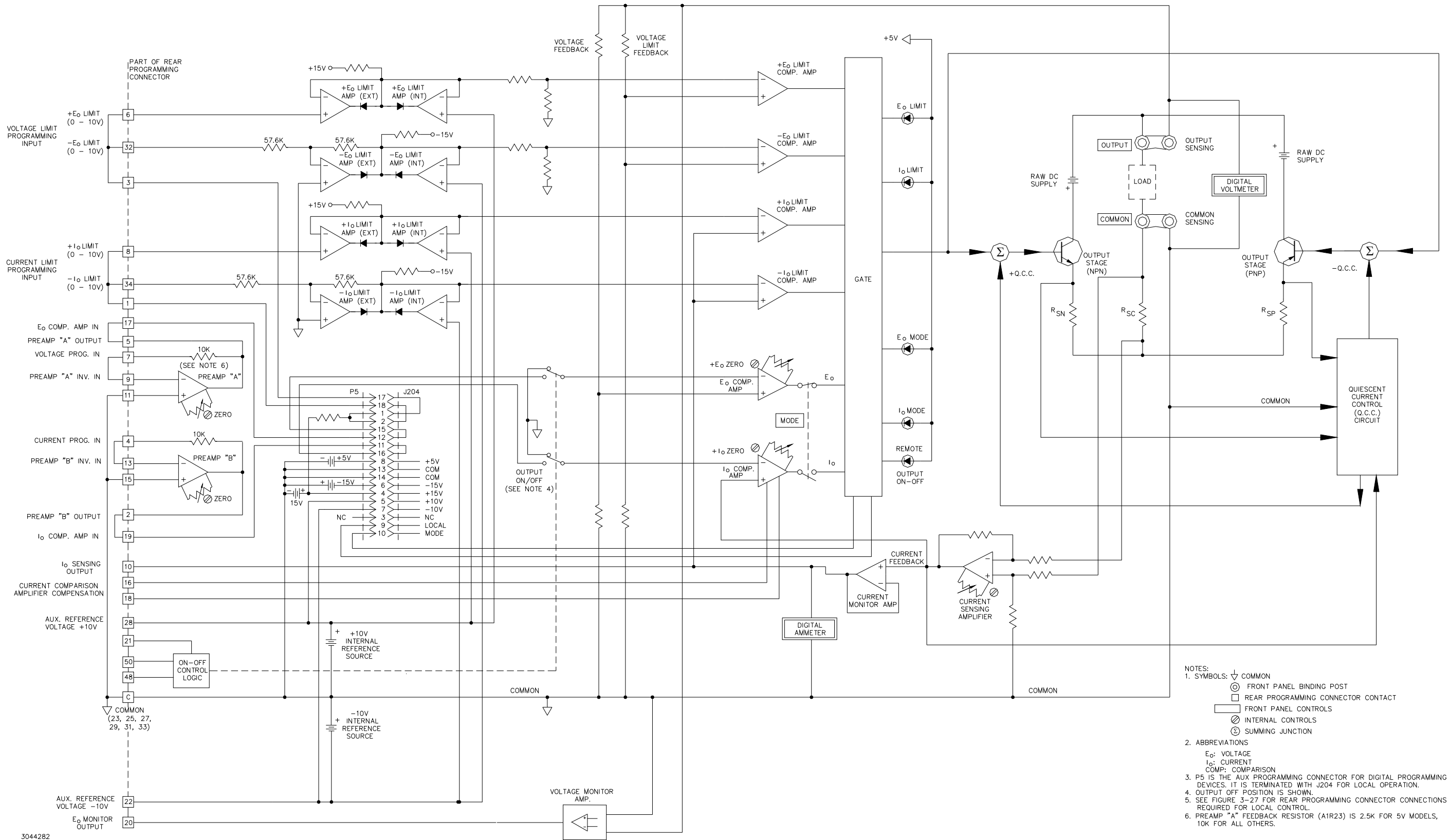

- NOTES:
- SYMBOLS:
    - ∇ COMMON
    - ⊙ FRONT PANEL BINDING POST
    - REAR PROGRAMMING CONNECTOR CONTACT
    - ▭ FRONT PANEL CONTROLS
    - ⊗ INTERNAL CONTROLS
    - ⊕ SUMMING JUNCTION
  - ABBREVIATIONS
    - $E_o$ : VOLTAGE
    - $I_o$ : CURRENT
    - COMP: COMPARISON
  - P5 IS THE AUX PROGRAMMING CONNECTOR FOR DIGITAL PROGRAMMING DEVICES. IT IS TERMINATED WITH J204 FOR LOCAL OPERATION.
  - OUTPUT OFF POSITION IS SHOWN.
  - SEE FIGURE 3-27 FOR REAR PROGRAMMING CONNECTOR CONNECTIONS REQUIRED FOR LOCAL CONTROL.
  - PREAMP "A" FEEDBACK RESISTOR (A1R23) IS 2.5K FOR 5V MODELS, 10K FOR ALL OTHERS.

FIGURE 3-26. SIMPLIFIED SCHEMATIC DIAGRAM, CHANNEL 1 OR 2, BOP 2X-D SERIES



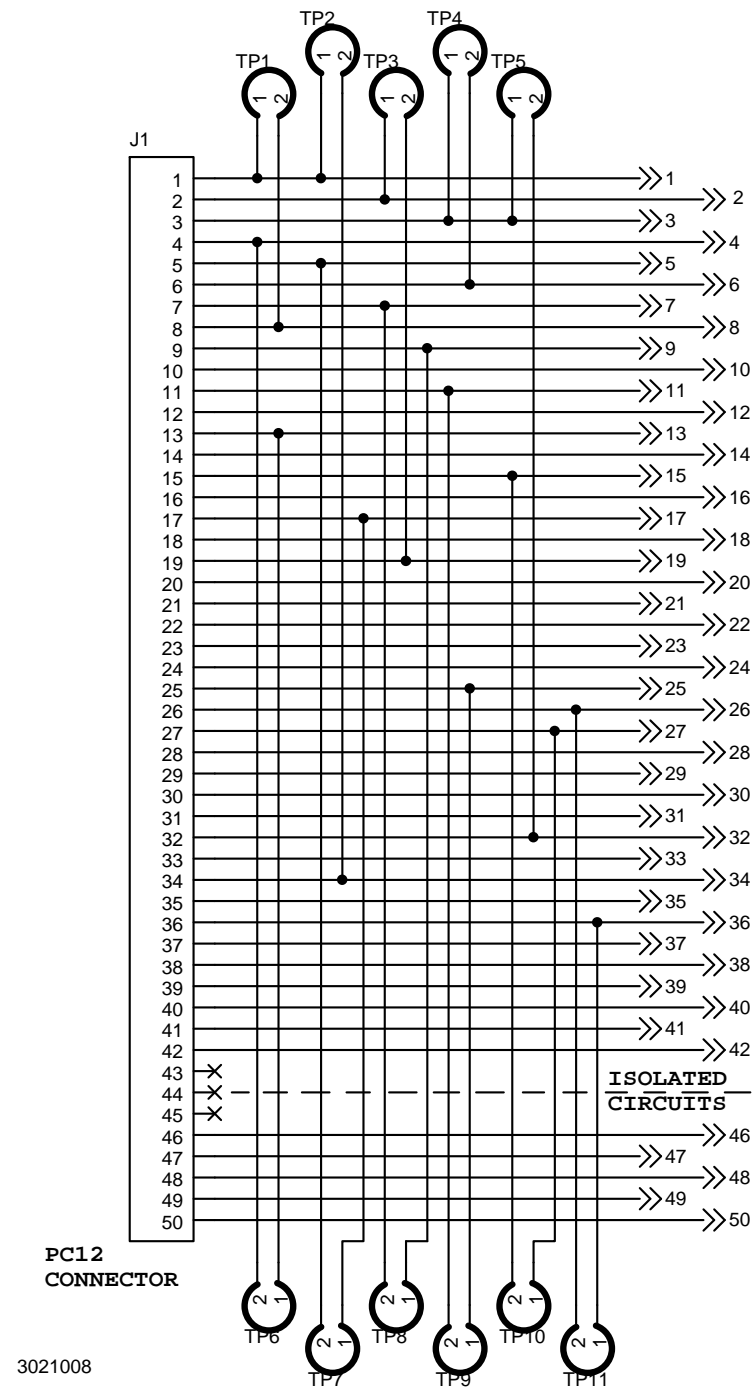

NOTES:

1. Connectors 195-0039 and 195-0121 both perform the same function. Connections shown are for PC 15, local control.

2. For P/N 195-0039, wires are added directly to the terminals for local control. User-added wires or components are connected directly to the terminals.

3. For P/N 195-0121 connections are made via the PWB traces and test points installed at the factory. The following table lists the pins connected when the test points are installed. For complete PWB connections, refer to the schematic diagram at the left.

TEST POINT	PINS CONNECTED WHEN TEST POINT INSTALLED	
	PIN 1	PIN 8
TP1	PIN 1	PIN 8
TP2	PIN 1	PIN 34
TP3	PIN 2	PIN 19
TP4	PIN 3	PIN 6
TP5	PIN 3	PIN 32
TP6	PIN 4	PIN 13
TP7	PIN 5	PIN 17
TP8	PIN 7	PIN 9
TP9	PIN 11	PIN 25
TP10	PIN 15	PIN 27
TP11	PIN 26	PIN 36

4. For P/N 195-0121 if necessary to isolate any pins connected by a test point, cut the test point. **CAUTION: Improper soldering technique may damage the PWB beyond repair.** Holes are provided at the test points for user-added wires or components. In addition, three holes per pin are provided on the PWB for user-added wires or components.

5. PC 12 (unwired) is supplied either without wires or without test points, depending on the connector used.

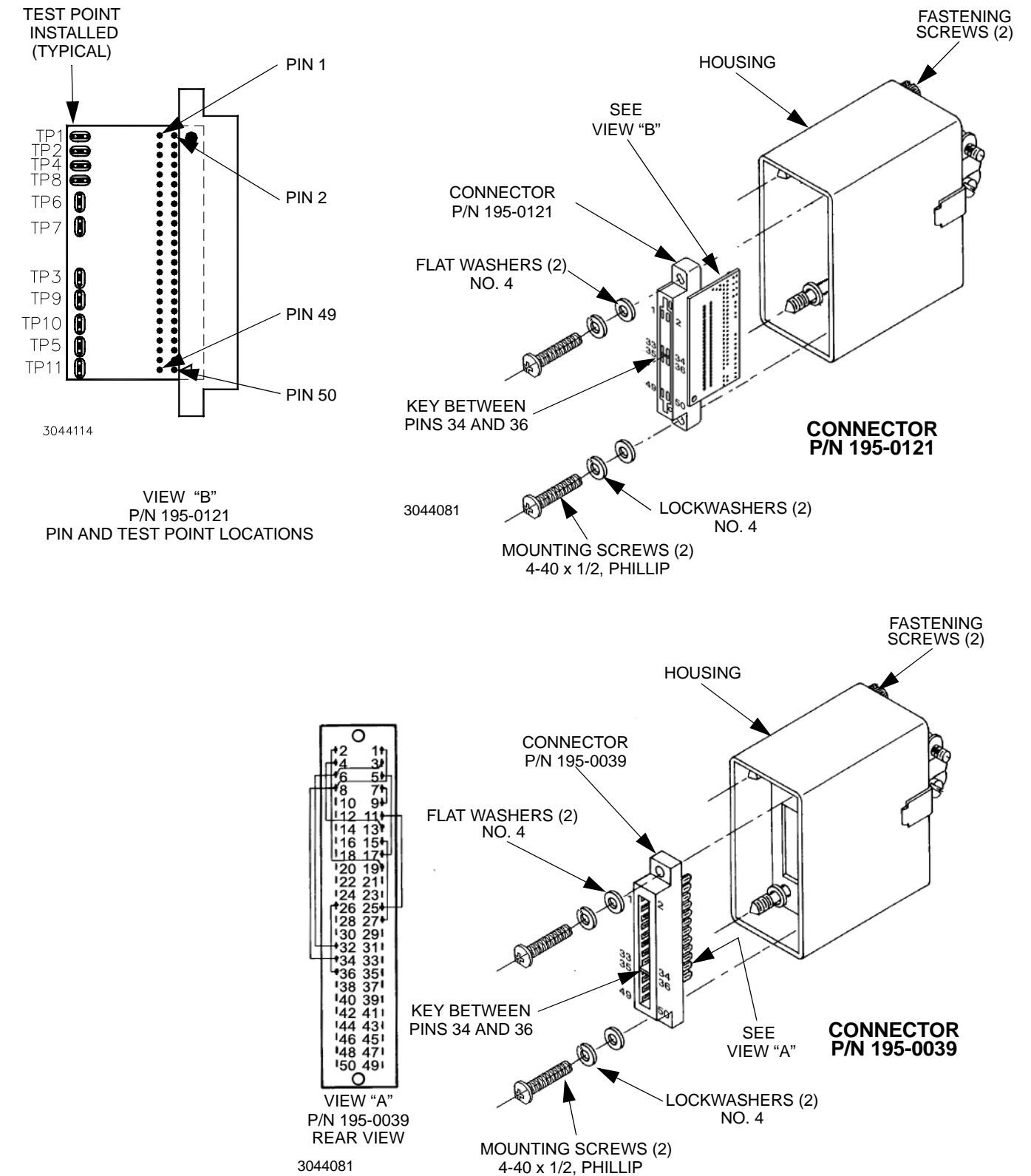

Figure 3-27. PC 15/PC 12 Rear Programming Connector Interconnections



## SECTION 4 - CALIBRATION

### 4.1 INTRODUCTION



#### WARNING

**Hazardous voltage is present within the unit when powered on while the cover is removed. Removal of the cover is permitted only by authorized Service personnel. Procedures and instructions found in this section are to be performed by authorized Service personnel only.**

Calibration and adjustment procedures for either BOP 2X-D channel are listed in Table 4-1. The locations of all internal controls are illustrated in Figure 4-1. Unless otherwise specified, procedures apply to one channel of both M and D suffix models as well as ML/DL and MC/DC options.

**TABLE 4-1. INTERNAL ADJUSTMENTS AND CALIBRATIONS**

Reference Designation	Control Name	Purpose	Adjustment Procedure
R31, R32	$\pm 10V$ CAL	Reference Voltage Calibration	PAR. 4.3.1
R41	PREAMP "A" ZERO	Uncommitted Amplifier "A" Zero Adjustment	PAR. 4.3.2
R42	PREAMP "B" ZERO	Uncommitted Amplifier "B" Zero Adjustment	PAR. 4.3.3
R81	$E_O$ COMP AMP ZERO	Voltage Channel Zero Adjustment	PAR. 4.3.4
R50	Ammeter Zero	Sensing Amplifier Offset Adjustment	PAR. 4.3.5
R83	$I_O$ COMP AMP ZERO	Current Channel Zero Adjustment	PAR. 4.3.6
R133 <sup>(1)</sup>	$I_O$ OFF ZERO	Current Channel Zero Adjustment for OFF status	PAR. 4.3.6
R136 <sup>(1)</sup>	$E_O$ OFF ZERO	Voltage Channel Zero Adjustment for OFF status	PAR. 4.3.6
R316	$I_O$ FS	Full Scale Output Current Calibration	PAR. 4.3.7
(1) Output OFF (disabled) status must be applied at ON-OFF CONTROL for this adjustment.			

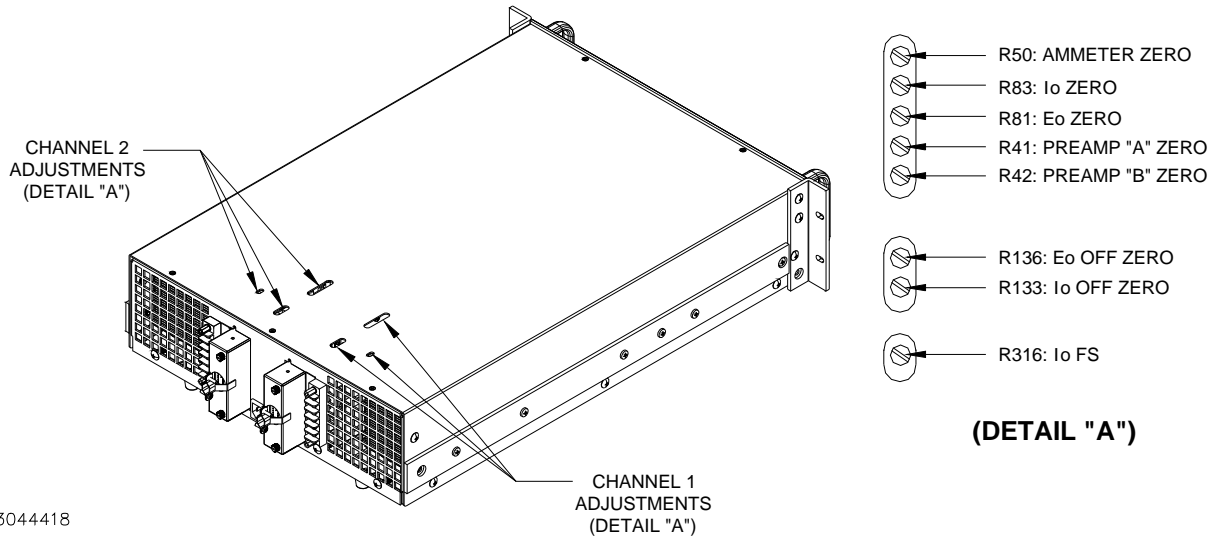

NOTE: See PAR. 3.2.1 and Figure 3-27 for Rear Programming Connector details.

**FIGURE 4-1. LOCATIONS OF ADJUSTMENT AND CALIBRATION CONTROLS**

## 4.2 TEST EQUIPMENT REQUIREMENTS

Table 4-2 lists sense resistors recommended for measuring current and includes Kepco and Manufacturer's part numbers. The value of the sense resistor chosen should be known with 0.001% accuracy. If other than a recommended sense resistor is to be used, it must be rated for at least 100W power dissipation (actual power dissipation will be less than 10W). The thermal coefficient of the sense resistor chosen should be 10 ppm/°C or better.

The digital voltmeter (DVM) used to measure output voltage and the voltage across the current sensing resistor should have at least six digits, multiple ranges, the smallest resolution must be at least one microvolt and the accuracy must be at least 0.0001%.

To calibrate the external programming capabilities of the BOP 2X-D a DC reference voltage with the following minimum specifications is required.

- Value: 0.0V  $\pm$ 0.1mV and 10.0V  $\pm$ 0.1mV (either positive and negative or floating)
- Stability: better than  $10^{-5}$
- Internal Impedance: better than 0.1 Ohms
- Output Current: >0.5mA when sourcing, >0.15mA when sinking



**TABLE 4-2. SUGGESTED SENSE RESISTORS**

MODEL	VALUE	KEPCO PART NO.	MANUFACTURER	MANUFACTURER PART NO.
BOP 2X5-20D BOP 2X5-30D BOP 2X20-5D BOP 2X20-10D BOP 2X36-6D	0.001 OHM	115-3033	ISOTEK	RUG-Z-R001-0.1 TK10
BOP 2X50-2D BOP 2X50-4D BOP 2X72-3D BOP 2X100-1D BOP 2X100-2D	0.01 OHM	115-2997	ISOTEK	RUG-Z-R010-0.1 TK10
NOTE: Selected sense resistor must be mounted on a heatsink with a minimum surface area of 36 square inches to maintain thermal stability during calibration; forced cooling is recommended. Kepco Heatsink P/N 136-0451 will provide adequate cooling for the sense resistor.				

### 4.3 INTERNAL ADJUSTMENTS AND CALIBRATIONS

See Figure 4-1 for location of adjustment controls. For complete calibration of the unit it is recommended that the adjustments be done in the order presented.



NOTES: 1. These controls are factory calibrated. Recalibration is necessary only if components related to the circuitry involving these controls have been replaced or if there are indications that the unit is out of calibration.

2. Before using the BOP 2X-D channels in any application, please refer to Section 2 to get acquainted with the operating controls, a-c power requirements and information on load connections and grounding.

3. The Rear Programming Connector for each channel must be installed at all times.

#### 4.3.1 ADJUSTMENT OF $\pm 10$ VOLT CALIBRATION CONTROLS (R31, R32)

1. Turn both BOP 2X-D channels off and disconnect the unit from source power. Then remove the BOP 2X-D cover: 9 screws on each side, 1 screw at front, 1 screw on top

NOTE: The following procedure is applicable to either channel.

2. With the BOP 2X-D powered off connect a DVM (see PAR. 4.2) to the Rear Programming Connector of the channel to be calibrated, from COMMON (pin 23, 25, 27, 29, 31 or 33) to pin 28 (+10V) and subsequently to pin 22 (-10V).

3. Locate the calibrating controls for the corresponding channel: R31 (+10V) and R32 (-10V). See Figure 4-1 for location. Turn on BOP channel to be calibrated.

4. First adjust R31 control to +10 Volts  $\pm 0.1$ mV on the digital voltmeter.

5. Move the DVM from pin 28 of the Rear Programming connector to pin 22 and adjust R32 to -10V  $\pm 0.1$ mV.

6. Turn off BOP channel.

7. Repeat steps 2 through 6 for the other channel.

### 4.3.2 PREAMPLIFIER “A” ZERO (R41)

NOTE: The following procedure is applicable to either channel.

1. Before adjusting Preamplifier “A” Zero control, turn both BOP channels off and configure the preamplifier of the channel to be calibrated: set amplification factor as desired, either inverting or non-inverting,

NOTE: Whenever Preamplifier “A” configuration is changed, this Zero control R41 should be readjusted.

2. Without a load connected to the output of the BOP 2X-D channel to be calibrated, place a short circuit across the input of Preamplifier “A.” For the default inverting configuration the short circuit is placed across the Rear Programming Connector of the channel to be calibrated from pin 9 to pin 11.
3. Set BOP channel to Voltage Mode by removing the connection between the corresponding Rear Programming Connector pin 30 and COMMON (pin 23, 25, 27, 29, 31 or 33).
4. Connect the DVM to the same Rear Programming Connector from COMMON (pin 23, 25, 27, 29, 31 or 33) to pin 5.
5. Locate the Preamplifier “A” Zero control R41 for the channel to be calibrated (see Figure 4-1).
6. Turn on BOP 2X-D channel and adjust R41 for  $0V \pm 0.1mV$  on the DVM.
7. Turn off BOP 2X-D channel.
8. Repeat steps 1 through 7 to calibrate the other channel.

### 4.3.3 PREAMPLIFIER “B” ZERO (R42)

NOTE: The following procedure is applicable to either channel.

1. Before adjusting Preamplifier “B” Zero control, turn both BOP channels off and configure the preamplifier of the channel to be calibrated: set amplification factor as desired, either inverting or non-inverting,

NOTE: Whenever Preamplifier “B” configuration is changed, this Zero control R42 should be readjusted

2. Without a load connected to the output of the BOP 2X-D channel to be calibrated, place a short circuit across the input of Preamplifier “B.” For the default inverting configuration the short circuit is placed across the Rear Programming Connector of the channel to be calibrated from pin 13 to pin 15.
3. Set BOP 2X-D channel to Voltage Mode by removing the connection between the corresponding Rear Programming Connector pin 30 and COMMON (pin 23, 25, 27, 29, 31 or 33).
4. Connect the DVM to the corresponding Rear Programming Connector from COMMON (pin 23, 25, 27, 29, 31 or 33) to pin 2.

5. Locate the Preamplifier "B" Zero control R42 for the channel to be calibrated (see Figure 4-1).
6. Turn on BOP 2X-D channel and adjust R42 for  $0V \pm 0.1mV$  on the DVM.
7. Turn off BOP 2X-D channel.
8. Repeat steps 1 through 7 for the other channel,

#### **4.3.4 VOLTAGE CHANNEL ZERO ADJUSTMENT (R81)**

NOTE: The following procedure is applicable to either channel.

1. Turn off both BOP channels. Without a load connected to the BOP 2X-D channel output to be calibrated, connect a digital voltmeter to terminal 1 (OUTPUT SENSE) of TB 201 on the rear panel of the channel to be calibrated (see Figure 2-2), with DVM return to TB 201 terminal 6 (COMMON SENSING).
2. Set BOP 2X-D channel to Voltage Mode by removing the connection between the corresponding Rear Programming Connector pin 30 and COMMON (pin 23, 25, 27, 29, 31 or 33).
3. Place a short circuit across the input of Preamplifier "A" of the channel to be calibrated. For the default inverting configuration the short circuit is placed across the corresponding Rear Programming Connector from pin 9 to pin 11.
4. Turn BOP 2X-D channel on and locate the corresponding Voltage Channel Zero Adjustment (R81, see Figure 4-1).
5. Adjust R81 for output voltage of  $0V \pm (0.00001 \times E_{O\text{nom}})$  where  $E_{O\text{nom}}$  is the nominal (rated) output voltage of the BOP 2X-D channel (in Volts). So, e.g., for BOP 2X50-4D the tolerance is  $0.00001 \times 50 = \pm 0.0005V$ .
6. Turn off BOP 2X-D channel.
7. Repeat steps 1 through 7 for the other channel,

#### **4.3.5 AMMETER ZERO CONTROL ADJUSTMENT (R50)**

NOTE: The following procedure is applicable to either channel.

1. Without a load connected to the BOP 2X-D channel output to be calibrated, connect a digital voltmeter to the corresponding Rear Programming Connector from COMMON (pin 23, 25, 27, 29, 31 or 33) to pin 10.
2. Set BOP channel to Voltage Mode by removing the connection between the corresponding Rear Programming Connector, pin 30 and COMMON (pin 23, 25, 27, 29, 31 or 33).
3. Locate AMMETER ZERO control for the channel to be calibrated (R50, see Figure 4-1) and turn corresponding BOP 2X-D channel on.
4. Adjust corresponding R50 control to 0 Volts  $\pm 0.1mV$  on the digital voltmeter.
5. Repeat steps 1 through 4 for the other channel,

#### 4.3.6 CURRENT CHANNEL ZERO ADJUSTMENT (R83)

NOTE: The following procedure is applicable to either channel.

1. Turn off BOP 2X-D channel to be calibrated. Without a load connected to the BOP 2X-D channel output, connect a precision 4-terminal current sensing shunt resistor (see Table 4-2) across the corresponding OUTPUT and COMMON terminals at the rear panel, Figure 2-2).
2. Connect the DVM to the shunt's sensing terminals.
3. Set BOP channel to Current Mode by installing a connection between the corresponding Rear Programming Connector, pin 30 and COMMON (pin 23, 25, 27, 29, 31 or 33).
4. Place a short circuit across the input of Preamplifier "B" of the channel to be calibrated, For the default inverting configuration the short circuit is placed across the corresponding Rear Programming Connector from pin 13 to pin 15.
5. Locate Current Channel Zero Adjustment for the channel to be calibrated (R83, see Figure 4-1) and turn BOP 2X-D channel on.
6. Adjust corresponding R83 for output voltage of  $0V \pm (0.0001 \times I_{O\text{nom}} \times R_S)V$  where  $I_{O\text{nom}}$  is the nominal (rated) output current of the BOP 2X-D channel (in Amps) and  $R_S$  is the resistance of the current sensing shunt resistor (in Ohms). So, e.g., for BOP 2X50-4D with a 0.01-Ohm shunt resistor the tolerance is  $0.0001 \times 4 \times 0.01 = \pm 0.00004V$ .
7. Turn off BOP 2X-D channel.
8. Repeat steps through 7 for the other channel,

#### 4.3.7 FULL SCALE OUTPUT CURRENT CALIBRATION (R316)

NOTE: The following procedure is applicable to either channel.

1. Turn both BOP 2X-D channels off and disconnect the unit from source power.
2. Without a load connected to the BOP 2X-D channel output to be calibrated, connect a precision 4-terminal current sensing shunt resistor (see Table 4-2) across the corresponding OUTPUT and COMMON terminals at the rear panel, Figure 2-2).
3. Connect the DVM to the shunt's sensing terminals.
4. Connect  $-10V \pm 0.1mV$  reference voltage across the corresponding Rear Programming Connector via an external 10K Ohm resistor:  $-10V$  to pin 13, return to pin 15 as shown in Figure 3-3.
5. Reconnect unit to source power and turn on BOP 2X-D channel. Locate R316 for the channel to be calibrated (see Figure 4-1).



CAUTION: To avoid the possibility of accidentally shorting a component to chassis ground, use a screwdriver with insulated shaft and small tip blade for this adjustment.

6. Adjust corresponding R316 so that the DVM connected to the current sensing shunt indicates  $(I_{O\text{nom}} \times R_S)V$  where  $I_{O\text{nom}}$  is the nominal (rated) output current of the BOP 2X-D channel (in Amps) and  $R_S$  is the resistance of the current sensing shunt resistor (in Ohms). Tolerance is  $\pm 0.0001 \times I_{O\text{nom}}$  (in Amperes)  $\times R_S$  (in Ohms). So, e.g., for BOP 2X50-4D with a 0.01-Ohm shunt resistor adjust R316 for  $0.0001 \times 4 \times 0.01 = 0.04V \pm 0.00004V$ .
7. Repeat steps 1 through 6 for the other channel,

#### 4.3.8 ADJUSTMENT OF $I_{O\text{-OFF ZERO}}$ (A1R133) AND $E_{O\text{-OFF ZERO}}$ (A1R136)

1. At the front panel of BOP 2X-D channel to be calibrated, set the POWER switch to OFF.
2. At the rear panel of the BOP 2X-D channel to be calibrated, connect a wire jumper between terminals 21 and 23 of the Rear Programming connector to set the output to OFF (disabled).
3. Connect precision shunt resistor across the BOP OUTPUT and COMMON terminals of the BOP 2X-D channel to be calibrated. Connect DVM to the shunt's sensing terminals for output current measurements.
4. Set BOP 2X-D channel to Current Mode by making a connection between the corresponding Rear Programming Connector pin 30 and COMMON (pin 23, 25, 27, 29, 31 or 33), then set the channel POWER switch at front panel to ON.
5. Adjust  $I_{O\text{-OFF ZERO}}$  (A1R133) potentiometer of the BOP 2X-D channel to be calibrated (see Figure 4-1) for  $0A \pm(0.01\% \text{ of } I_{O\text{nom}})$  as read on the DVM connected to the shunt. E.g., for BOP 2X5-20D  $I_{O\text{nom}}$  is 20A and adjustment tolerance is  $\pm 2\text{mA}$ .
6. Turn off BOP 2X-D channel and remove the shunt resistor from the output. Connect the DVM to the output sensing terminals of the BOP channel to be calibrated (OUT S and COM S).
7. Set BOP 2X-D channel to Voltage Mode by removing the connection between the corresponding Rear Programming Connector pin 30 and COMMON (pin 23, 25, 27, 29, 31 or 33), then set the channel POWER switch at front panel to ON.
8. Adjust  $E_{O\text{-OFF ZERO}}$  (A1R136) of the BOP 2X-D channel to be calibrated for  $0V \pm(0.01\% \text{ of } E_{O\text{nom}})$  as read on DVM. E.g., for BOP 2X5-20D  $E_{O\text{nom}}$  is 5V and adjustment tolerance is  $\pm 0.5\text{mV}$ .
9. Turn off BOP 2X-D channel and repeat steps 1 through 8 above for the other channel.

