

INSTRUCTION MANUAL

GROUP EFX 210-T

POWER SUPPLY

40 ~ 50kHz -4 OUTPUT
SWITCHING POWER SUPPLIES

KEPCO INC.
An ISO 9001 Company.

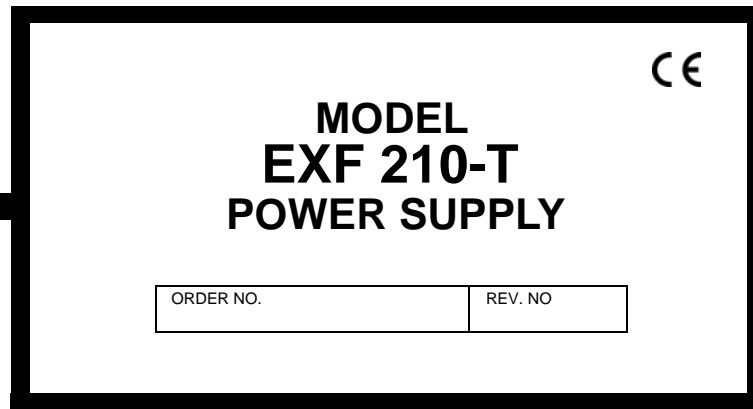

NOTE: This on-line Version of the Technical Manual includes only installation and operating instructions. For the complete manual, please contact Kepco.

©2000, KEPCO, INC.



KEPCO, INC. • 131-38 SANFORD AVENUE • FLUSHING, NY. 11355 U.S.A. • TEL (718) 461-7000 • FAX (718) 767-1102
email: hq@kepcopower.com • World Wide Web: www.kepcopower.com

TABLE OF CONTENTS

PARAGRAPH	PAGE
SECTION I—INTRODUCTION	
1-1 Scope of Manual.....	1-1
1-3 Description.....	1-1
1-7 Specifications	1-2
SECTION II—INSTALLATION AND OPERATION	
2-1 Unpacking and Inspection	2-1
2-4 Repacking for Shipment.....	2-1
2-6 Input Source Selection	2-1
2-8 Fuse Change.....	2-1
2-10 Installation.....	2-1
2-12 Load Connections	2-3/2-4
SECTION III—THEORY OF OPERATION	
3-1 Simplified Diagram Discussion	3-1/3-2
3-7 Circuit Description.....	3-5
SECTION IV—MAINTENANCE	
4-1 General	4-1
4-3 Periodic Maintenance.....	4-1
4-5 Performance Measurements	4-1
4-7 Test Equipment Required.....	4-1
4-8 Measurement Techniques	4-1
4-15 Trouble Shooting.....	4-3
4-19 Final Check.....	4-13
4-25 Repair and Replacement.....	4-14
SECTION V—ELECTRICAL PARTS LIST AND DIAGRAMS	
5-1 General.....	5-1/5-2
5-3 Ordering Information.....	5-1/5-2

LIST OF ILLUSTRATIONS

FIGURE	PAGE
1-1 Kepco EFX Series Open Frame Switching Power Supply	iii/iv
1-2 Derating Graph for Operation from 50 °C to 71 °C	1-3/1-4
2-1 EFX Power Supply, Simplified Top View	2-1
2-2 Mechanical Outline Drawing	2-2
2-3 Recommended Load Connections (Diagram).....	2-3/2-4
3-1 Simplified Schematic Diagram, EFX 210T Series.....	3-3/3-4
3-2 Input Filter and Off-Line Rectifier with Main D-C Supply.....	3-5
3-3 Simplified Schematic Diagram, Forward Converter Circuit (General).....	3-6
3-4 EFX Forward Converter Circuit (Diagram)	3-7
3-5 Voltage Error Amplifier (Diagram), Master	3-8
3-6 Overvoltage Protection Circuit, Dead Band Control and Pulse Slow Start Circuit.....	3-9
3-7 Current Limit Circuit (Diagram).....	3-10
4-1 Application of 4-Terminal Network Technique for Measuring Output Effects (Diagram).....	4-1
4-2 Flow-Chart No. 1	4-7/4-8
4-3 Flow Chart No. 2	4-9/4-10
4-4 Switching Wave Forms for EFX Power Supply (Graph).....	4-11/4-12
4-5 Connections for Viewing Ripple with Single-Ended Oscilloscope.....	4-13
4-6 Output Ripple and Noise (Photo)	4-13
4-7 Disassembly/Re-Assembly, EFX 210T Series	4-14
5-1 Component Location, EFX 210T Power Supply	5-33/5-34
5-2 Schematic Diagram, EFX 210T Power Supply	5-35/5-36

LIST OF TABLES

TABLE	PAGE
1-1 Output Ratings, EFX 210T Series.....	1-1
1-2 Output Stabilization.....	1-2
1-3 Output Cross Stabilization	1-2
1-4 Output Ripple and Noise Specifications	1-3/1-4
4-1 Trouble Shooting Data	4-5/4-6

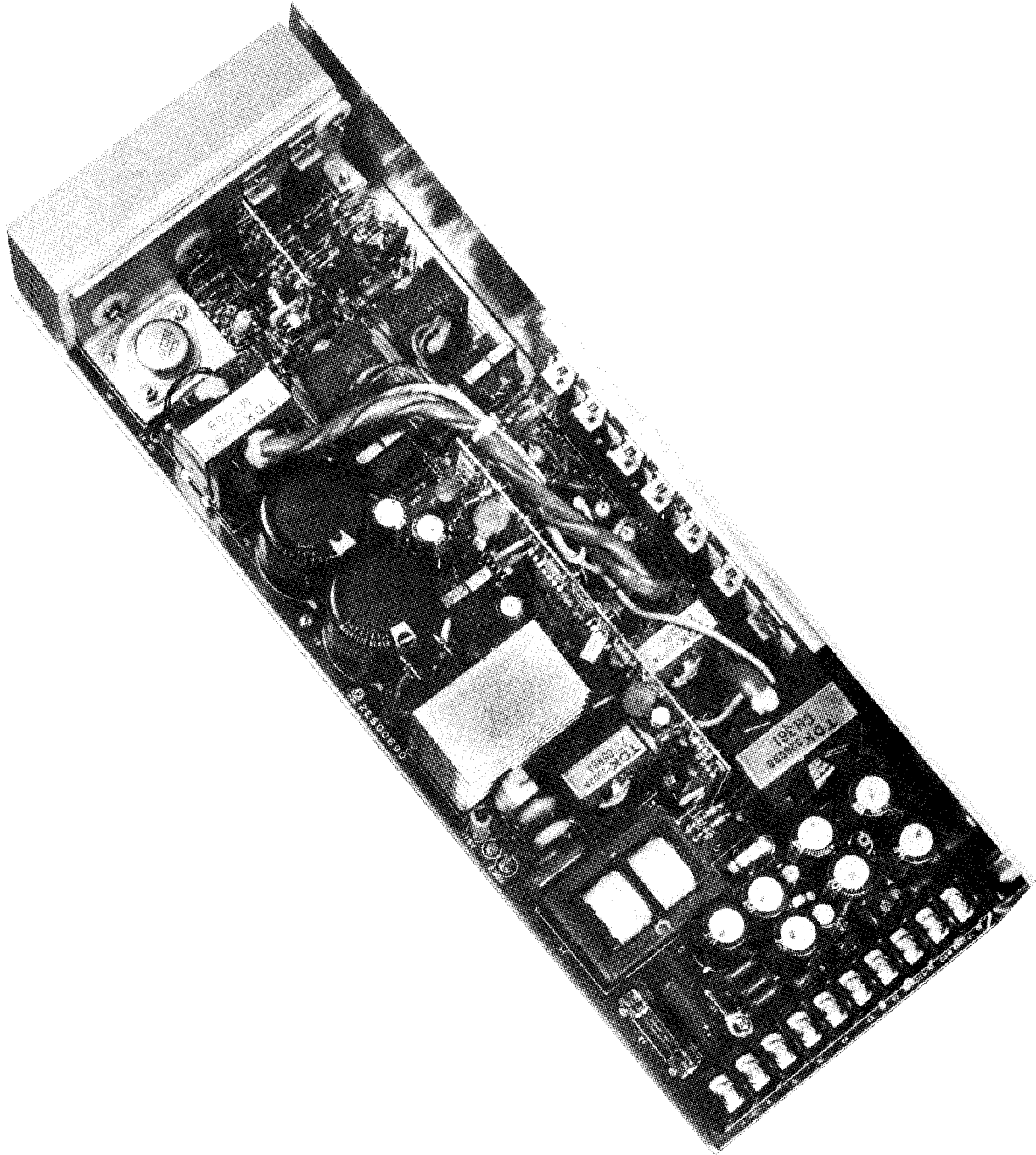

FIG. 1-1 KEPCO EFX 210-T SERIES OPEN FRAME SWITCHING POWER SUPPLY.

SECTION I—INTRODUCTION

1-1 SCOPE OF MANUAL

1-2 This manual contains instructions for the installation, operation and maintenance of the Kepco Series EFX 210T Switch Mode Power Supplies.

1-3 DESCRIPTION

1-4 The EFX 210T power supply series consists of several models of switching power supplies, having one principal output of 5 volts and three (3) auxiliary outputs of various ratings, as listed in Table 1-1.

1-5 All EFX models will operate from single phase a-c power lines, in the range from 100 to 130V a-c or, by setting an internal source selector, in the range from 200 to 260V a-c. All EFX models have soft start circuits to prevent excessive input surge current. The input is protected against short-circuits by means of a fuse. All outputs are protected against over-currents and over-voltages by means of overvoltage protection and current limit circuits.

1-6 The EFX power supply is of the "Open Frame" construction⁽¹⁾ and can be mounted on either one of its two mounting surfaces. All inputs and outputs are terminated on a single, heavy duty barrier strip. Single board construction and clear identification of all components on the printed circuit board should be helpful if servicing becomes necessary.

MODEL	TOTAL POWER	PRINCIPAL OUTPUT		AUXILIARY OUTPUTS					
		V ₁		V ₂		V ₃		V ₄	
		VOLTS	AMPS	VOLTS	AMPS	VOLTS	AMPS	VOLTS	AMPS
EFX 210T-1	220W	+ 5V	20A	+ 24V	1.0A	+ 12V	4.0A	- 12V	4.0A
EFX 210T-2	214W	+ 5V	20A	+ 24V	1.0A	+ 15V	3.0A	- 15V	3.0A
EFX 210T-3	206W	+ 5V	20A	- 5V	2.0A	+ 12V	4.0A	- 12V	4.0A
EFX 210T-4	200W	+ 5V	20A	- 5V	2.0A	+ 15V	3.0A	- 15V	3.0A

TABLE 1-1 OUTPUT RATINGS, EFX 210T SERIES.

(1) An optional, perforated cover, Model CA-14, is available for the Series EFX 210T power supplies.

1-7 SPECIFICATIONS:

- A) INPUT SOURCE VOLTAGE: 100 to 130V a-c or 200 to 260V a-c, 47 to 440 Hz, single phase.
BROWNOUT VOLTAGE: 90V a-c/180V a-c. The EFX power supply will function at the brownout level with minor degradation in the specifications for ripple, stabilization and holding time.
- B) INPUT SOURCE CURRENT AT 25 °C: MAXIMUM⁽¹⁾, 2.5A/4.5A; TYPICAL⁽²⁾, 1.8A/3.6A. Typical⁽²⁾ input surge current: 40A/20A.

⁽¹⁾ MEASURED AT 200/100V a-c INPUT VOLTAGE AND FULL LOAD (50 °C LEVEL).

⁽²⁾ MEASURED AT 230/115V a-c INPUT VOLTAGE AND FULL LOAD (50 °C LEVEL).

- C) INPUT PROTECTION AND SOFT START: All EFX power supplies are protected at turn-on by a fuse against short circuits in the input circuit. A soft start circuit prevents excessive input surge current.
- D) EFFICIENCY: Greater than 78% at full load.
- E) OUTPUT RATINGS: See Table 1-1.
- F) OUTPUT ADJUSTMENT RANGE: ± 10%, Principal Output only; Auxiliary Outputs are fixed. The location of the output adjustment rheostat is shown in Section II, FIG. 2-1.
- G) CURRENT LIMIT AND SHORT CIRCUIT PROTECTION: All outputs are protected by fixed, individual current limit circuits, set as follows: V1, V3, V4: 100 to 140% of the nominal output current at 50 °C. V2: 100 to 200% of the nominal output current at 50 °C.
- H) OVER-VOLTAGE PROTECTION. Outputs V1, V3 and V4 are protected by a fixed over-voltage circuit. Threshold level is 120 to 140% of the nominal output voltage. The overvoltage circuit is reset by removing the input source power for approximately 40 seconds.
- J) OUTPUT SETTING ACCURACY: All auxiliary outputs are within ± 5% of their tabulated value when the principal output is set to the nominal value (5 volts) and the power supply is fully loaded.
- K) OUTPUT STABILIZATION: Refer to Table 1-2

INFLUENCE QUANTITY	PRINCIPAL OUTPUT		AUXILIARY OUTPUTS	
	Typ.	Max.	Typ.	Max.
SOURCE EFFECT (Min-Max)	<0.5%	1.0%	<0.5%	1.0%
LOAD EFFECT (20—100%)	<0.5%	1.0%	<5.0%	10.0%
TEMPERATURE EFFECT (0—50°C)	<0.5%	1.0%	<0.5%	1.0%
COMBINED EFFECT (Envelope)	<1.0%	3.0%	<6.0%	12.0%
TIME EFFECT (drift, 8 hr @ 25°C)	<0.02%	0.1%	<0.02%	0.1%

TABLE 1-2 OUTPUT STABILIZATION.

- L) OUTPUT CROSS STABILIZATION: See Table 1-3.

NOTE: This specification expresses the influence on each of the outputs when the load on another output is changed by the amount listed.

OUTPUTS	Typ.	Max.
PRINCIPAL OUTPUT (Change any output 20-100% of rated load):	0.1%	0.5%
AUXILIARY (Change principal output 50-100% of rated load):	3%	8%
AUXILIARY (Change load on any output, other than the principal output, 20-100% of rated load):	1%	2%

TABLE 1-3 OUTPUT CROSS STABILIZATION.

- M) OUTPUT RECOVERY FROM LOAD CHANGES (ALL OUTPUTS): A step load change from 50 to 100% of the rated load current produces less than 5% output voltage excursion (or 0.5 volt, whichever is greater). Recovery occurs to within 0.5% (or 0.05 volt whichever is greater) of the original output voltage setting in less than 5 milliseconds. Stepload rise or fall time must be greater than 5 microseconds.
- N) OUTPUT RIPPLE AND NOISE (ALL OUTPUTS): See Table 1-4.

RIPPLE COMPONENT	ALL OUTPUTS	
	Typ.	Max.
2x Source frequency	25mV p-p	100mV p-p p-p max.
2x Switching frequency	50mV p-p	
Spike Voltage (to 10MHz)	1% E _o + 50mV	

TABLE 1-4 OUTPUT RIPPLE AND NOISE SPECIFICATIONS.

- O) OUTPUT HOLDING TIME: On a-c input interruption or failure, the d-c output will be maintained for a minimum of 20 milliseconds (30 ms typical) at full load and nominal input source.
- P) AMBIENT OPERATING TEMPERATURE RANGE: 0° to 71°C.
NOTE: No derating for 0°C to 50°C operation. For operation to 71°C, output current for all outputs must be derated linearly from 50°C to 71°C to a value of 40% at 71°C, see FIG. 1-2.
- Q) STORAGE TEMPERATURE RANGE: - 25°C to + 75°C.
- R) HUMIDITY RANGE:
 OPERATING: 30 to 85% RH (Non-Condensing)
 STORAGE: 20 to 90% RH
- S) ISOLATION (At 20°C ambient temperature, 65% relative humidity).
 Between input and output terminals: 2.5KV a-c for 1 minute.
 Between input terminals and chassis: 2.5KV a-c for 1 minute.
 Between output terminals and chassis: 500V d-c, 100 megohm.
- T) VIBRATION: 5-10 Hz, 10 mm amplitude, 3 axes.
 10-55 Hz, 2G, 3 axes.
 SHOCK: 20G, 3 axes, 11 ± 5 milliseconds pulse duration.

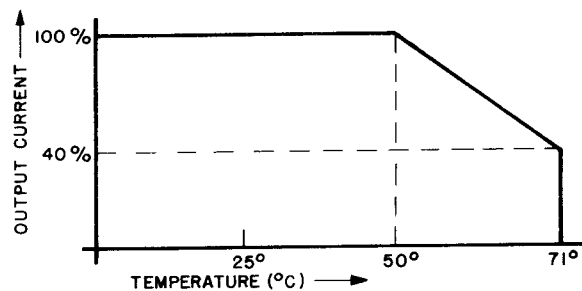

FIG. 1-2 DERATING GRAPH: USE FOR OPERATION FROM 50°C-71°C AMBIENT TEMPERATURE.

SECTION II—INSTALLATION AND OPERATION

2-1 UNPACKING AND INSPECTION

2-2 MECHANICAL CHECK. The Kepco EFX power supply has been inspected and tested prior to packing and is ready for installation and operation. Before permanent installation, the unit should be inspected for shipping damage. If such damage is found, retain the original shipping container and notify the responsible carrier.

2-3 ELECTRICAL CHECK. The unit should be checked electrically, by doing the PERFORMANCE MEASUREMENTS as described in Section IV paragraphs 4-5 through 4-14.

2-4 REPACKING FOR SHIPMENT

2-5 To insure safe shipment, repack unit into its original shipping container.

NOTE: DO NOT SHIP PARTS OR INSTRUMENTS TO KEPKO UNLESS AUTHORIZATION TAGS AND INSTRUCTIONS HAVE BEEN PROVIDED. Contact your Kepco Sales Representative for instructions.

2-6 INPUT SOURCE VOLTAGE SELECTION

2-7 All EFX power supplies can be operated on a-c, single phase power lines (47 to 440 Hz). The units are normally delivered for operation on a 100 to 130 a-c source. For operation on a 200 to 260V a-c source, remove the wire jumper from the "115" position and reconnect it to the "230" position, see FIG. 2-1.

2-8 FUSE CHANGE (See FIG. 2-1)

2-9 The a-c fuse is located on the printed circuit board and is clearly marked with fuse number and value. See FIG. 2-1.

2-10 INSTALLATION (See Mechanical Outline Drawing. FIG. 2-2)

2-11 The EFX power supply may be mounted and operated in any position. Two mounting surfaces are provided, as shown in FIG 2-2. Care should be taken that the air immediately surrounding the power supply does not exceed the specified ambient temperature. Cooler power supply operation can often be achieved by mounting the unit onto a heat conducting surface. For operation in ambient temperatures greater than 50°C, linear derating of the output current must be applied, see Section I, paragraph 1-7P.

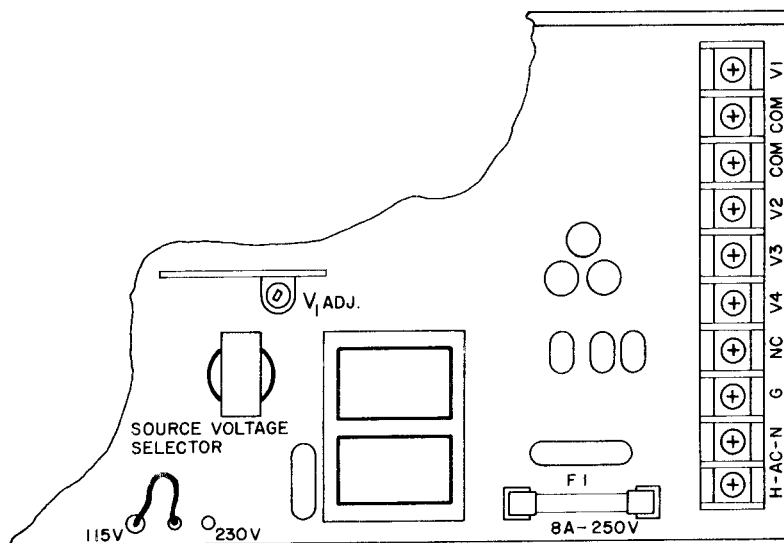

FIG. 2-1 EFX 210T POWER SUPPLY, SIMPLIFIED TOP-VIEW.

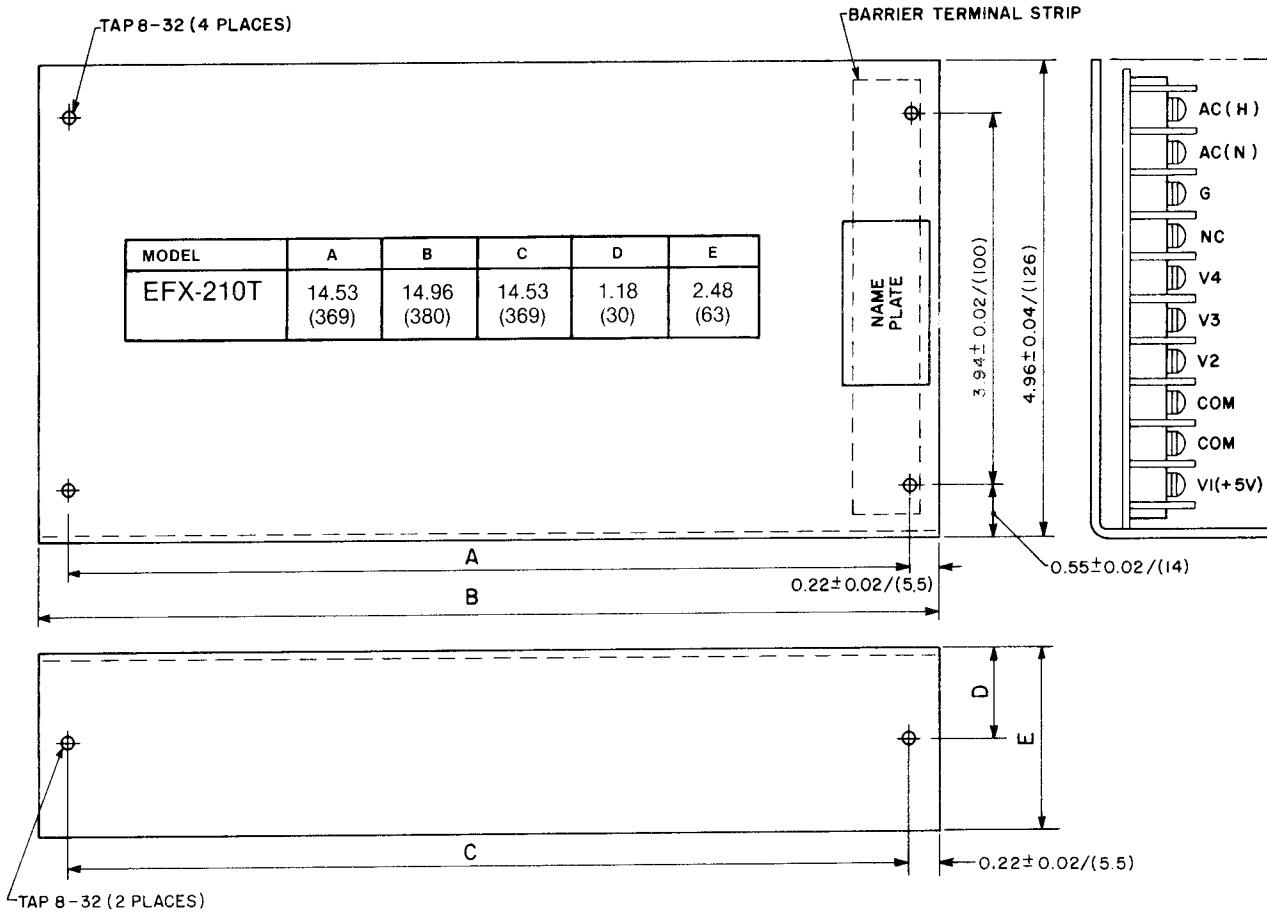

FIG. 2-2 MECHANICAL OUTLINE DRAWING, EFX 210T SERIES.

- Notes: 1) Dimensions are in inches. Dimensions (in parentheses) are in millimeters.
 2) TOLERANCES: 0.02" (0.5 mm) between mounting holes, 0.04" (1.0 mm) other dimensions.
 3) Maximum mounting screw penetration: 1/8 inch.
 4) Chassis Material & Finish: Phosphate treated aluminum.
 5) Weight: EFX 210T: 2.3 Kg./4.9 Lbs. approximately.

2-12 LOAD CONNECTIONS

2-13 The load should be connected to the individual outputs of the EFX power supply as indicated in FIG. 2-3. Load wires should be as short as possible. Select the heaviest practicable wire gauge and twist all load-wire pairs tightly.

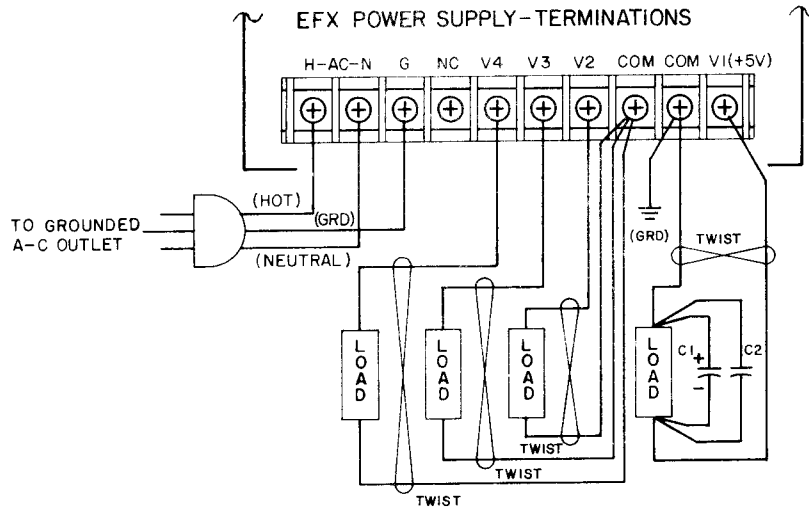

FIG. 2-3 RECOMMENDED LOAD CONNECTIONS

NOTE: Please refer to Section I, Table 1 for the relationship between output designations V1, V2, V3 and V4 and the actual output voltage values for your EFX Model.

2-14 As shown in FIG. 2-3, each load has its own return to the common ground point. The two terminals "COM" are internally connected. If the common ground point must be established elsewhere, then all load return wires should terminate at the new ground point. THE IMPORTANCE OF A SINGLE GROUND POINT IN THE LOAD CIRCUIT CAN NOT BE OVERSTATED. MULTIPLE GROUND POINTS RESULT IN GROUND LOOPS WHICH CAUSE GREATLY INCREASED RIPPLE AND NOISE. For minimum ripple and noise at the load, an additional filter may be required at each load (see FIG. 2-3, 5V output). The filter consists of a pair of low/high frequency bypass capacitors (C1 = 50 μ F electrolytic, C2 = 0.1 μ F film-type).