

INSTRUCTION MANUAL

MPS 620M POWER SUPPLY

MULTIPLE OUTPUT POWER SUPPLY

KEPCO INC.
An ISO 9001 Company.

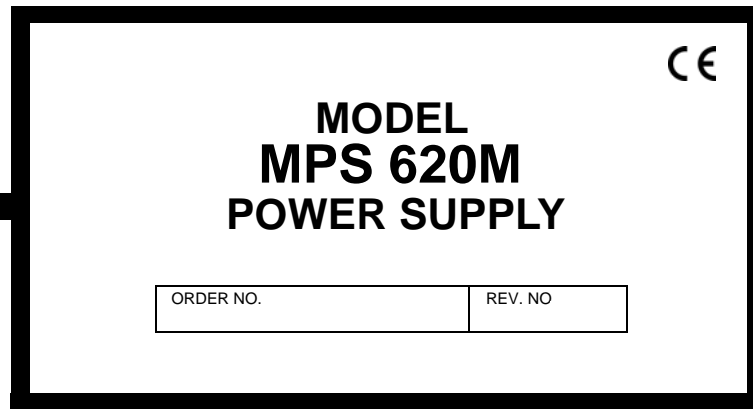

NOTE: This on-line version of the Technical Manual includes only installation and operating instructions. For the complete manual, please contact Kepco

©2006, KEPCO, INC.
P/N 243-047



KEPCO, INC. • 131-38 SANFORD AVENUE • FLUSHING, NY. 11355 U.S.A. • TEL (718) 461-7000 • FAX (718) 767-1102
email: hq@kepcopower.com • World Wide Web: www.kepcopower.com

TABLE OF CONTENTS

PARAGRAPH		PAGE
SECTION I – INTRODUCTION		
1-1	Scope of Manual	1-1
1-3	General Description	1-1
1-6	Specifications, General	1-1
1-7	Specifications, 6V-5A Section	1-2
1-8	Specifications, (±)20V-1A Section	1-2
SECTION II – INSTALLATION		
2-1	Unpacking and Inspection	2-1
2-3	Terminations	2-1
2-4	A-C Input Voltage Conversion	2-3
2-6	Cooling	2-3
2-8	Preliminary Check-Out	2-3
2-10	Crowbar Check	2-4
2-11	Installation	2-4
SECTION III – OPERATION		
3-1	General	3-1
3-3	Safety Grounding	3-1
3-6	Signal Grounding	3-1
3-10	Power Supply/Load Interface	3-2
3-14	Load Wire Selection	3-2
3-16	Load Connection (±)20V-1A Supply	3-3
3-18	Load Connection, 6V, 5A Supply	3-4
SECTION IV – THEORY OF OPERATION		
4-1	Simplified Diagram Discussion	4-1
4-10	Circuit Description	4-2
SECTION V – MAINTENANCE		
5-1	General	5-1
5-4	Disassembly	5-1
5-5	Adjustment of the Internal Current Limit	5-2
5-7	Trouble Shooting	5-2
5-11	Power Supply Measurements	5-3

LIST OF ILLUSTRATIONS

FIGURE		PAGE
1-1	Kepeco Model MPS 620M, Multiple Output D-C Stabilized Power Supply, Front and Rear View	-iii/iv-
1-2	Mechanical Outline Drawing	1-3/1-4
2-1	Front Controls and Terminations, Model MPS 620M2-1
2-2	Rear Terminations, Model MPS 620M2-2
2-3	Location of the Internal Current Limit Control2-2
2-4	Location of the A-C Source Selector2-3
3-1	Typical Output Impedance vs. Frequency Plot for Stabilized D-C Voltage Sources3-2
3-2	Load Connections, (\pm)20V-1A Supply3-3
3-3	Load Connections, 6V-5A Supply3-4
4-1	Simplified Schematic Diagram, Master/Slave D-C Source, (\pm)20V-1A Supply4-4
4-2	Simplified Schematic Diagram, 6V-5A Supply	4-7/4-8
4-3	Simplified Schematic Diagram, (\pm)20V-1A Supply4-9/4-10
5-1	Removing the Wrap-Around Cover and the Printed Circuit Boards from the Model MPS 620M5-1
5-2	Connections for Output Effect Measurements5-4
6-1	Plug-In Diagram, Model MPS 620M6-19/6-20
6-2	Component Location, Main Chassis6-21/6-22
6-3	Component Location, Assembly A16-23/6-24
6-4	Component Location, Assembly A36-25/6-26
6-5	Main Schematic Diagram, Model MPS 620M6-27/6-28

LIST OF TABLES

TABLE		PAGE
1-1	D-C Output Effects vs. Change in Listed Influence Quantities1-1
2-1	Front Panel Controls and Terminations2-1
2-2	Rear Terminations2-2
3-1	Internal Signal Ground Components3-1

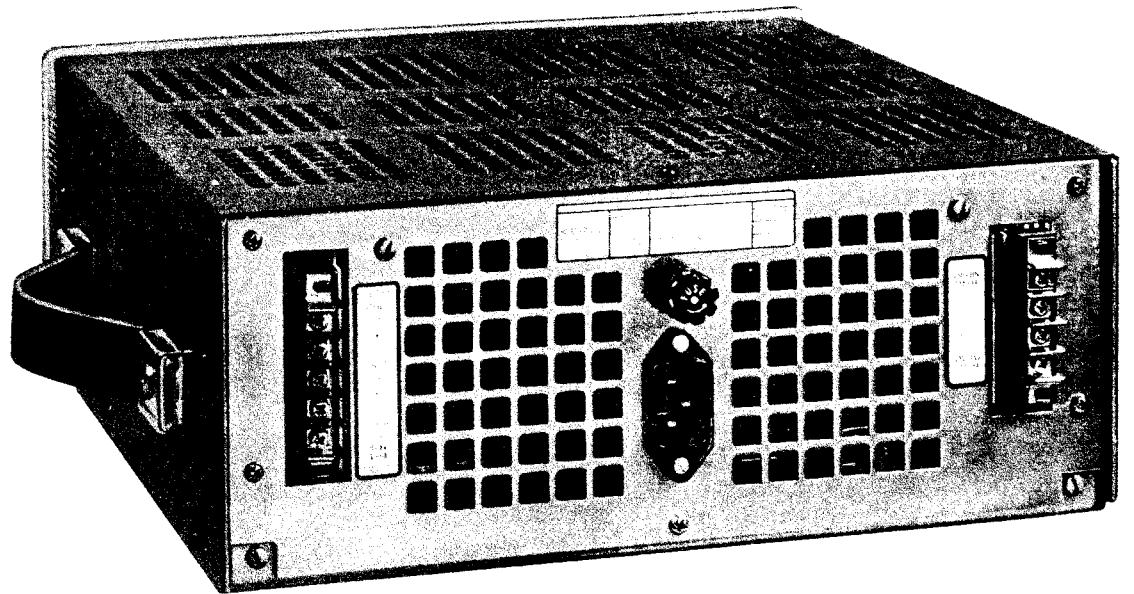

FIG. 1-1 KEPCO MODEL MPS 620M, MULTIPLE OUTPUT D-C POWER SUPPLY, FRONT AND REAR VIEW.

SECTION I—INTRODUCTION

1-1 SCOPE OF MANUAL

1-2 This manual contains instructions for the installation, operation and maintenance of the Model MPS 620M Multiple Output Power Supply, manufactured by Kepco Inc., Flushing, New York, U.S.A.

1-3 GENERAL DESCRIPTION

1-4 The Kepco Model MPS 620M is a multi-output, "bench-top" power supply, which provides the necessary voltage and current capability for the operation of most IC's and microprocessors. The Model MPS 620M consists of two main sections. The 6 volt, 5 ampere output section is equipped with an adjustable crowbar and crowbar light at the front panel and with remote error sensing terminals. The dual tracking ± 20 volt, 1 ampere section is equipped with adjustable current limiting. Both sections have precision 10-turn voltage controls at the front panel. The output voltage as well as the output currents are monitored by front panel voltage meters. Both outputs are completely short-circuit proof by virtue of an extremely sharp current limit characteristic. Both outputs are terminated at the front panel binding posts and at the barrier strip terminals at the rear of the power supply.

1-5 The Model MPS 620M is constructed in a three-quarter rack package. The chassis and wrap-around cover are made from cold-rolled steel, while the front panel material is aluminum. (Refer to the Mechanical Outline Drawing, FIG. 1-2)

1-6 SPECIFICATIONS, GENERAL

- a) A-C SOURCE POWER REQUIREMENTS: 105-125 a-c *or* 210 to 250V a-c, selectable by an internal a-c Source Selector (refer to Section II of this manual), 50 to 440 Hz, single phase. approximately 250W.
- b) D-C OUTPUT: See Table 1-1

INFLUENCE QUANTITY	OUTPUT EFFECTS	
	0 to 6V output	0 to $\pm 20V$ outputs
SOURCE: 105-125/210-250V a-c, 50-440 Hz	0.01%	0.01%
LOAD: No load - full load	0.01% ⁽¹⁾	0.05% ⁽¹⁾
TIME: 8-hour drift	0.01%	0.01%
TEMPERATURE: Per °C	0.01% ⁽¹⁾	0.01% ⁽¹⁾
RIPPLE AND NOISE	rms	0.1 mV
	p-p	1 mV

⁽¹⁾ or 5 mv, whichever is greater.

TABLE 1-1 D-C OUTPUT EFFECTS vs. CHANGE IN LISTED INFLUENCE QUANTITIES.

- c) OPERATING TEMPERATURE: (–) 20 °C to (+) 50 °C. Full output current at 50 °C without derating.
- d) STORAGE TEMPERATURE: (–) 40 °C to (+) 85 °C.
- e) ISOLATION FROM GROUND: The circuit and output terminals have no d-c connection to ground and may be floated up to 300 volts (d-c or peak) off ground.
- f) VOLTAGE RECOVERY: The time required for the stabilized voltages to recover within 10 millivolts of the original voltage setting following a step in load current between 10% and 100% of the rated load is less than 50 μ sec. typical, 100 μ sec. maximum.
- g) SERIES/PARALLEL. The two (\pm) 20 volt outputs can be used in series to provide 0 to 40 volt at 1 ampere. They share a common (center) terminal and therefore cannot be used in parallel.
- h) METERS: Two recessed 2½" meters displaying voltage and current for all (3) outputs. Selected by a 3-position meter selector switch at the front panel.
- j) ACCESSORIES (NOT SUPPLIED): The Model MPS 620M can be rack-mounted, using the Kepco Model RA-24 Rack Adapter. The MPS occupies ¾ of the adapter width. The remaining ¼ width may be used to mount any Kepco "quarter-rack" model, or may be filled using a Filler Panel, Kepco Model RFP 24-1.

1-7 SPECIFICATIONS, 6V, 5A SECTION

- a) OUTPUT VOLTAGE RANGE: 0 to 6 volts continuously adjustable with ten-turn front panel control.
- b) CURRENT RATING: 0 to 5 amperes.
- c) REMOTE ERROR SENSING: Error sensing terminals (at the front panel, as well as in the rear) permit remote sensing at the load by means of a 4-terminal connection. Remote sensing compensates for static load wire voltage drops of up to 0.5 volt per lead. An additional 1 volt of output voltage (beyond the 6 volt rating) is provided for this purpose.
- d) CURRENT LIMITING: A fixed current limit is provided at approximately 110% (5.5A). The power section of MPS 620M has sufficient thermal capacity to maintain operation indefinitely into a dead short circuit. The output recovers automatically when the overload is relieved. The output locus is a rectangular characteristic, it is not a fold-back circuit.
- e) CROWBAR: The output is monitored by a front panel adjustable overvoltage crowbar circuit. The crowbar level can be set in the range from 4 to 8 volts. A crowbar indicator lamp is provided at the front panel.

1-8 SPECIFICATIONS, (\pm) 20V, 1A SECTION

- a) OUTPUT VOLTAGE RANGE (Two Outputs): 0 to (–) 20 volt and 0 to (+) 20 volt, simultaneously adjustable with a single, 10-turn front panel control. Tracking between outputs is better than \pm 1% + 10 mV.
- b) CURRENT RATING (EACH OUTPUT) 0 to 1 ampere.
- c) CURRENT LIMITING: The current limit point of both outputs can be pre-set with a single internal control, in the range of 10 to 110% of the rated output current (0.1 to 1.1A). The power section of MPS 620M has sufficient thermal capacity to maintain operation indefinitely into a dead short circuit. The output recovers automatically when the overload is relieved. The output locus has a rectangular characteristic, it is not a fold-back circuit.

1-9 MECHANICAL SPECIFICATIONS:

SEE "MECHANICAL OUTLINE DRAWING," FIG. 1-2.

SECTION II – INSTALLATION

2-1 UNPACKING AND INSPECTION

2-2 This instrument has been thoroughly inspected and tested prior to packing and is ready for operation. After careful unpacking, inspect for shipping damage before attempting to operate. Perform the preliminary operational check as outlined in paragraph 2-8 below. If any indication of damage is found, file an immediate claim with the responsible transport service.

2-3 TERMINATIONS

a) FRONT PANEL: Refer to FIG. 2-1 and Table 2-1.

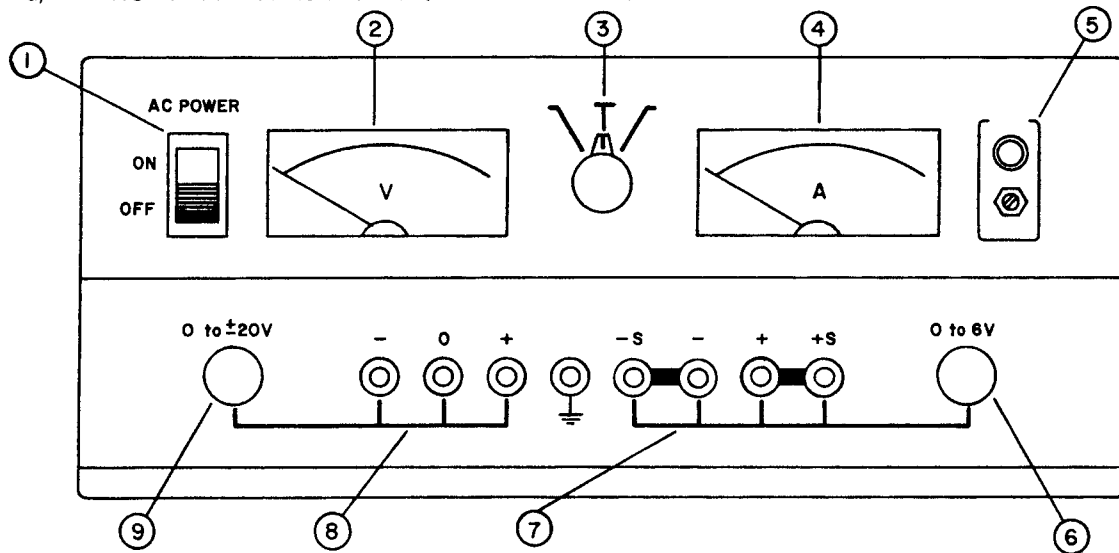

FIG. 2-1 CONTROLS AND TERMINATIONS, MODEL MPS 620M.

NO.	CONTROL OR TERMINATION	FUNCTION
1	A-C POWER SWITCH	A-C POWER LINE ON-OFF SWITCH, WITH "ON" LIGHT
2	VOLT METER	DISPLAYS EITHER 0 to 6V or 0 to $\pm 20V$ OUTPUT VOLTAGE, DEPENDING ON METER SELECTOR POSITION.
3	METER SELECTOR	CONNECTS VOLTAGE AND AMMETER TO (-) 20V, 1A, (+) 20V, 1A or 6V, 5A RANGES.
4	AMMETER	DISPLAYS EITHER 0 to $\pm 1A$, OR 0 to 5A OUTPUT CURRENT, DEPENDING ON METER SELECTOR POSITION.
5	CROWBAR LEVEL CONTROL AND INDICATOR	SCREWDRIVER CROWBAR LEVEL ADJUSTMENT, 4 TO 8 VOLTS. CROWBAR INDICATOR, LIGHTS IF 6V SUPPLY IS CROWBARED.
6	VOLTAGE CONTROL (0-6V)	SETS OUTPUT VOLTAGE LEVEL, 6 VOLT SECTION.
7	OUTPUT AND SENSING	FRONT OUTPUT FOR 6V, 5A SECTION, SENSING TERMINALS LINKED TO OUTPUT TERMINALS.
8	OUTPUT TERMINALS	FRONT OUTPUT FOR $\pm 20V$, 1A SUPPLY
9	VOLTAGE CONTROL, 0 TO (\pm) 20V	SETS OUTPUT VOLTAGE LEVEL, (\pm) 20V SUPPLY.

TABLE 2-1 FRONT PANEL CONTROLS AND TERMINATIONS

b) REAR: Refer to FIG. 2-2 and Table 2-2.

NO.	TERMINATION	FUNCTION
1	REAR BARRIER STRIP, 6V-5A SUPPLY	DUPLICATES FRONT TERMINALS
2	A-C POWER INPUT CONNECTOR	NEMA/IEC CONNECTOR ACCEPTS LINE CORD (SUPPLIED)
3	FUSE	PROTECTS PRIMARY CIRCUITS
4	REAR BARRIER STRIP, (\pm)20V-1A SUPPLY	DUPLICATES FRONT TERMINALS

TABLE 2-2 REAR TERMINATIONS, MODEL MPS 620M.

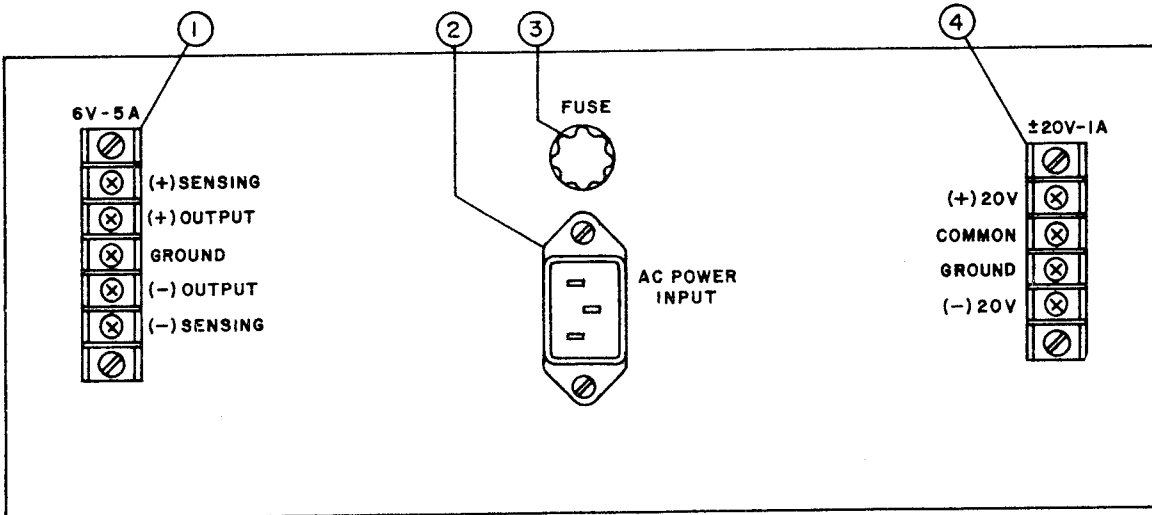

FIG. 2-2 REAR TERMINATIONS, MODEL MPS 620M.

c) INTERNAL CONTROL: See FIG. 2-3.

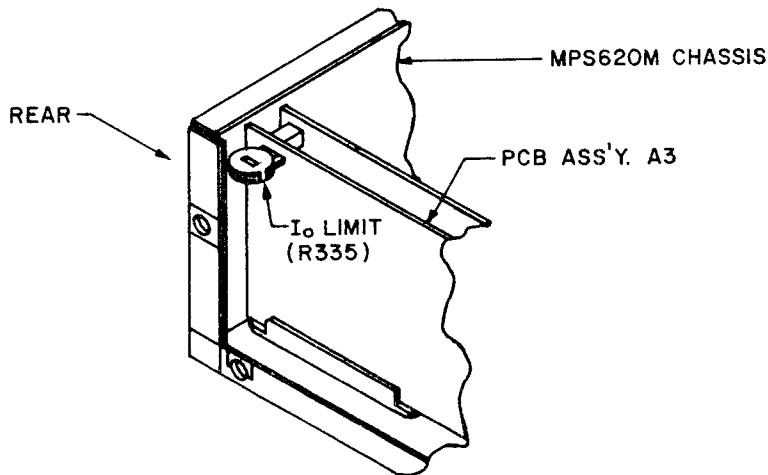

FIG. 2-3 LOCATION OF THE INTERNAL CURRENT LIMIT ADJUSTMENT FOR THE (\pm) 20V, 1A SUPPLY

2-4 A-C INPUT VOLTAGE CONVERSION.

- 2-5 This power supply is normally delivered for operation on a single phase, 115V a-c nominal a-c power line. For conversion to 230V a-c operation, set the A-C SOURCE SELECTOR (see FIG. 2-4) to the "230" position and change the fuse (see FIG. 2-2) to one half its former rating.

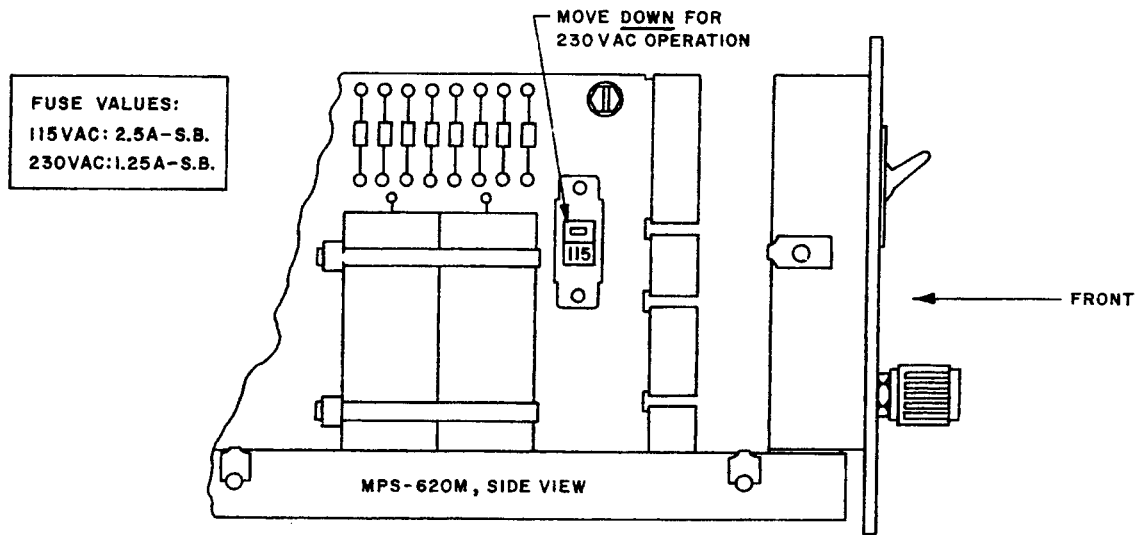

FIG. 2-4 LOCATION OF THE A-C SOURCE SELECTOR.

2-6 COOLING

- 2-7 Power dissipating components in the Model MPS 620M are cooled by convection. *Rear panel and cover openings must be kept clear from obstructions to insure proper air circulation.*

Periodic cleaning of the power supply interior is recommended. If the power supply is rack-mounted, or installed into other confined spaces, care must be taken that the temperature immediately surrounding the power supply does not rise beyond the specified maximum ambient operating temperature (50°C).

2-8 PRELIMINARY CHECK-OUT

- 2-9 A simple operating check after unpacking and before permanent installation is advisable to ascertain whether the power supply has suffered damage resulting from shipment. Refer to FIG. 2-1 and to FIG. 2-2 for the location of the operating controls and output terminals.
- Connect power supply to 115V a-c source, or refer to PAR. 2-4 for 230V a-c operation, if required.
 - Turn the A-C POWER switch of the Model MPS 620M "on." Set METER SELECTOR first to the "-20V/-1A" position. Turn the "0 TO $\pm 20V$ " front panel voltage control from fully counterclockwise to fully clockwise. The D-C VOLTMETER should indicate from the corresponding change from zero to approximately 20 volts.
 - Repeat with the METER SELECTOR in the "+20V/-1A" position.
 - Set METER SELECTOR to the "6V/5A" position. Turn the "0 to 6V" front panel voltage control from fully counterclockwise to fully clockwise. The D-C VOLTMETER should indicate the corresponding change from zero to approximately 6 volts. Turn the MODEL MPS 620M "off".
 - Connect a short length of wire between the (-) and (+) output terminals of both, the 0 to 6V-5A and the 0 to $\pm 20V$ -1A supply. Leave METER SELECTOR in the "6V/5A" position.
 - Turn Model MPS 620M "on". The short circuit current, as read out on the D-C AMPERE METER should be slightly more than 5A.
 - Turn METER SELECTOR to the "+20/+1A" and then to the "-20/-1A" positions. The D-C AMPERE METER should indicate a short circuit current slightly more than 1 ampere. Turn MPS 620M "off". Remove the wire jumpers from the output terminals.

2-10 CROWBAR CHECK:

- 1) Turn the MODEL MPS 620M "on" and set METER SELECTOR to the "6V/5A" position. Set the "0 to 6V" front panel voltage control for approximately 4V output.
- 2) With a screwdriver, turn the SET LEVEL crowbar control slowly counterclockwise until the CROWBAR light is "on". The front panel voltmeter should indicate a small *negative* output voltage.
- 3) *Back off* slightly on the "0 to 6V" voltage control and de-activate the overvoltage protector by momentarily turning the MPS 620M A-C POWER switch "off".
- 4) Turn MPS 620M A-C POWER switch "on" again. Slowly, turn the "0 to 6V" voltage control clockwise again and observe the crowbar level at the D-C VOLTMETER.

2-11 INSTALLATION (Refer to FIG. 1-2 "MECHANICAL OUTLINE DRAWING")

- 2-12 The MPS 620M power supply can be bench operated, or rack-mounted by means of the Kepco Model RA-24 Rack Adapter. If the MPS 620M is to be rack-mounted, the four (4) bottom feet and the front bail must be removed. Four (4) nylon mounting stand-offs are provided (two (2) of them are under the rear feet) which accept 8-18 thread-forming mounting screws.
- 2-13 For installation into confined spaces, care must be taken that the temperature immediately surrounding the power supply does not exceed the maximum rated ambient temperature (50°C).

SECTION III – OPERATION

3-1 GENERAL

- 3-2 Interconnections between an a-c power source and a stabilized power supply, and between the power supply and its load are as critical as the interface between any other electronic equipment. If optimum performance is expected, certain rules for the interconnection of source, power supply and load must be observed by the user. These rules are described in detail in the following paragraphs.

3-3 SAFETY GROUNDING

- 3-4 National and international safety rules dictate the grounding of the metal cover and case of any instrument connected to the a-c power source.

WARNING

KEEP INSTRUMENT GROUNDED WHILE IT IS CONNECTED TO THE A-C POWER SOURCE.

- 3-5 Kepco power supplies with flexible a-c power cord are equipped with a 3-prong safety plug, which must be connected to a grounded a-c power outlet.

3-6 SIGNAL GROUNDING

- 3-7 Connections between the power supply and the load (load and sensing connections), will invariably, despite all precautions such as shielding, twisting of wire-pairs, etc., "pick-up" radiated noise of a wide frequency spectrum. To minimize this undesired output, a SIGNAL GROUND is needed. The signal ground consists of a *single ground point*, either at one of the power supply output terminals or at one side of the load.
- 3-8 Kepco has provided an internal signal ground on both sections of the Model MPS 620M, consisting of a resistor/capacitor series combination from the output to the chassis. If, therefore, the chassis of the MPS 620M is a-c safety grounded by means of its three-prong plug, the safety, as well as the signal ground is automatically established.
- 3-9 The signal ground provided internally in the MPS 620M is sufficient for performance within specifications for most applications with an isolated load. If the load has its own ground, however, and high ripple is observed during operation, the internal signal ground in the MPS 620M may be removed by unsoldering the resistor associated with the signal ground.

DESIGNATION	SUPPLY	LOCATION	SECTION VI, FIG.
R46,	6V-5A	Assembly A1	6-3
R354,	±20V-1A	Assembly A3	6-4

TABLE 3-1 INTERNAL SIGNAL GROUND COMPONENTS

3-10 POWER SUPPLY/LOAD INTERFACE

- 3-11 The general function of a voltage or current stabilized power supply is to deliver the rated output quantities to the connected load. The load (or loads) may have any conceivable characteristic. It may be fixed or variable, it may have predominantly resistive, capacitive, or inductive parameters; and it may be located very close to the power supply, or it may be a considerable distance away. The power supply designer cannot anticipate every conceivable application, location or nature of the load. He must design his product for the widest possible application range and specify the performance at the output terminals of the power supply. The aim of the following paragraphs is to aid the user in the final use of the product: the interface of the power supply and the load.
- 3-12 The perfect interface between a power source and its load would mean that the specified performance at the output terminals would be transferred without impairment to any load, regardless of its characteristics, distance from the power supply or environment. To approach this ideal, the power supply must satisfy certain requirements, interconnecting rules must be closely followed and Ohm's Law, as well as basic a-c theory must be considered in selecting the interface wiring.
- 3-13 The stabilized d-c power supply is definitely not an ideal voltage or current source with zero output impedance (VOLTAGE MODE) at all frequencies. All voltage sources have some amount of impedance which increases with frequency. (Refer to FIG. 3-1). A more realistic model for a voltage stabilized power supply must, for example, include a series resistance, representing the small d-c and low frequency source impedance, in series with an inductance, representing the source impedance at higher frequencies.

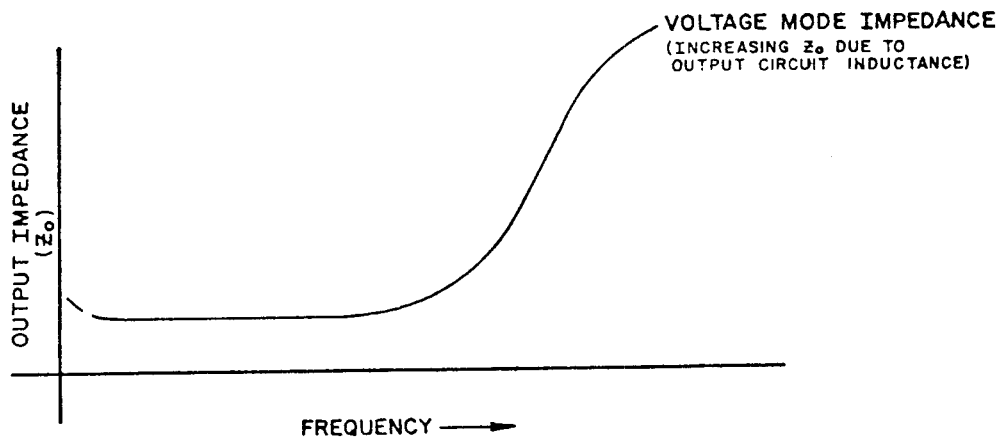

FIG. 3-1 TYPICAL OUTPUT IMPEDANCE VS. FREQUENCY PLOT FOR STABILIZED D-C VOLTAGE SOURCES.

3-14 LOAD WIRE SELECTION

- 3-15 Load wire selection should proceed considering the facts discussed in PAR's. 3-10 to 3-13. The load-wire size should not only be selected for minimum voltage drop, but also the series inductance of the load wire must be kept as small as possible compared to the source inductance of the power supply. These dynamic considerations are especially important if:
- 1) The load is constantly changing in value.
 - 2) The load is switched "on" and "off".
 - 3) The load has a primarily reactive characteristic.
 - 4) All other cases where the dynamic output response of the power supply is considered important.

IN PRACTICAL TERMS, THE LOAD WIRE SHOULD ALWAYS BE AS HEAVY AND AS SHORT AS POSSIBLE.

3-16 LOAD CONNECTION, (\pm) 20V - 1A SUPPLY (SEE FIG. 3-2)

3-17 For the low current (\pm) 20V supply, the interface with the load consists of a 2-wire connection from either the front, or the rear output terminals, The load wire should be selected as described (refer to PAR. 3-14) and should be tightly twisted to reduce "pick-up" from stray magnetic fields. After the grounding rules have been applied (refer to PAR's. 3-3 through 3-9, operation can begin.

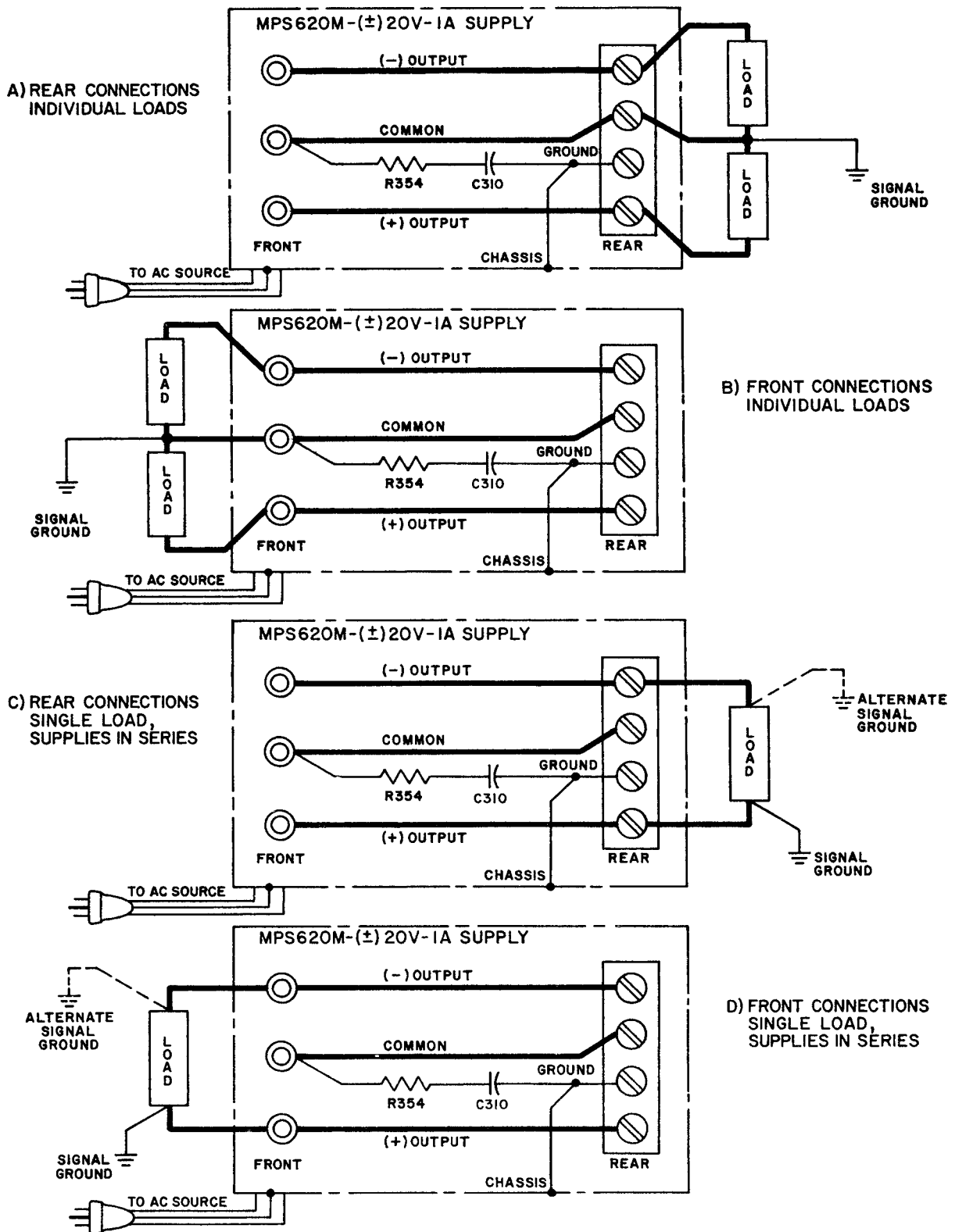

FIG. 3-2 LOAD CONNECTIONS, (\pm) 20V, 1A SUPPLY.

3-18 LOAD CONNECTION, (6V, 5A SUPPLY) (SEE FIG. 3-3).

3-19 The load may be connected in one of the ways illustrated in FIG. 3-3. **IMPORTANT NOTE: IF ERROR SENSING IS USED, THE SHORTING LINKS BETWEEN OUTPUT AND SENSING TERMINALS MUST BE COMPLETELY REMOVED. IF ERROR SENSING IS NOT USED, THE LINKS MUST BE CONNECTED AT THE FRONT, IF THE LOAD IS AT THE FRONT. THE LINKS MUST BE CONNECTED AT THE REAR, IF THE LOAD IS AT THE REAR.**

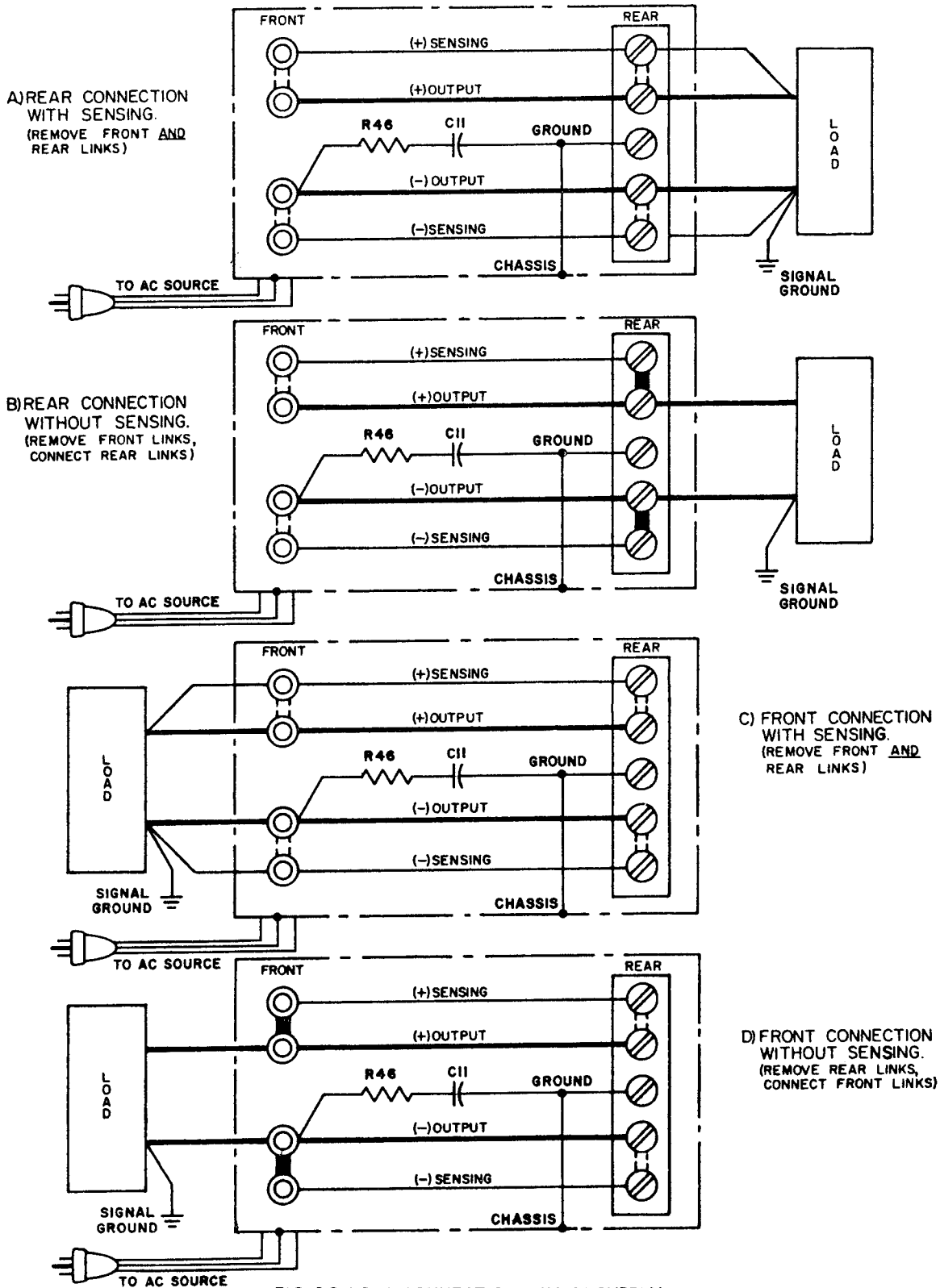

FIG. 3-3 LOAD CONNECTIONS, 6V, 5A SUPPLY.